

PRODUCT NO.	POSITION	REMARK	DIM "C"	DIM "D"	DIM "E"
I0053363-100LF	2X32	WITH KEY	54.61	54.46	3.50±0.25
I0053363-200LF	2X32	WITHOUT KEY	N/A	N/A	3.50±0.25
I0053363-201LF	2X32	WITHOUT KEY	N/A	N/A	2.60± ^{0.10} _{0.30}

NOTES:

- MATERIALS:
HOUSING: HIGH TEMPERATURE THERMOPLASTIC, UL 94V-0 RATED, BLACK.
TERMINAL: HIGH CONDUCTIVITY COPPER ALLOY.
CONTACT AREA: 30u" GOLD OVER 50u" NICKEL UNDERPLATED.
SOLDER TAIL: 100u" TIN OVER 50u" NICKEL UNDERPLATED.
- PRODUCT PERFORMANCE SPEC. PER GS-12-259.
- PACKAGE SPECIFICATION PER GS-14-937.
- PART NUMBER I0053363-X00LF MEETS EUROPEAN UNION DIRECTIVE AND OTHER COUNTRY REGULATIONS AS DESCRIBED IN GS-22-008. THE HOUSING WILL WITHSTAND EXPOSURE TO 260°C±5°C PEAK TEMPERATURE FOR 10 SECONDS IN A REFLOW SOLDER APPLICATION WITH A CIRCUIT BOARD.
- MANUFACTURER'S NAME, P/N AND DATE CODE TO APPEAR ON THIS SURFACE AS PER GS-24-007.

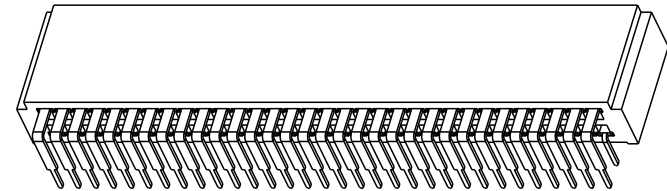
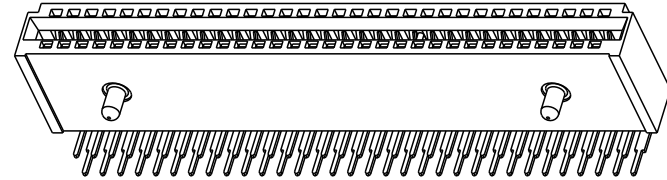

Copyright FCI.

spec ref *		dr wadmin		2006/08/07		projection		size A4		scale 1.000	
tolerance std		eng Wei-Long Zhang		2012/06/06						ecn no ELX-DG-011840-1	
TOLERANCES UNLESS OTHERWISE SPECIFIED		chr -		-						rel level Released	
surface ✓		appr Pei-Ming Zheng		2012/06/06		product family		dwg no 10053363		rev K	
linear		0.X ±0.30				title 2X32P RIGHT ANGLE POWER CARD EDGE		www.fci.com		cat. no. * Product - Customer Drw	
		0.XX ±0.15									
		0.XXX ±0.08									
angular		0° ±2°								sheet 1 of 3	

ProjE File - REV C - 2009-06-09



Copyright FCI.

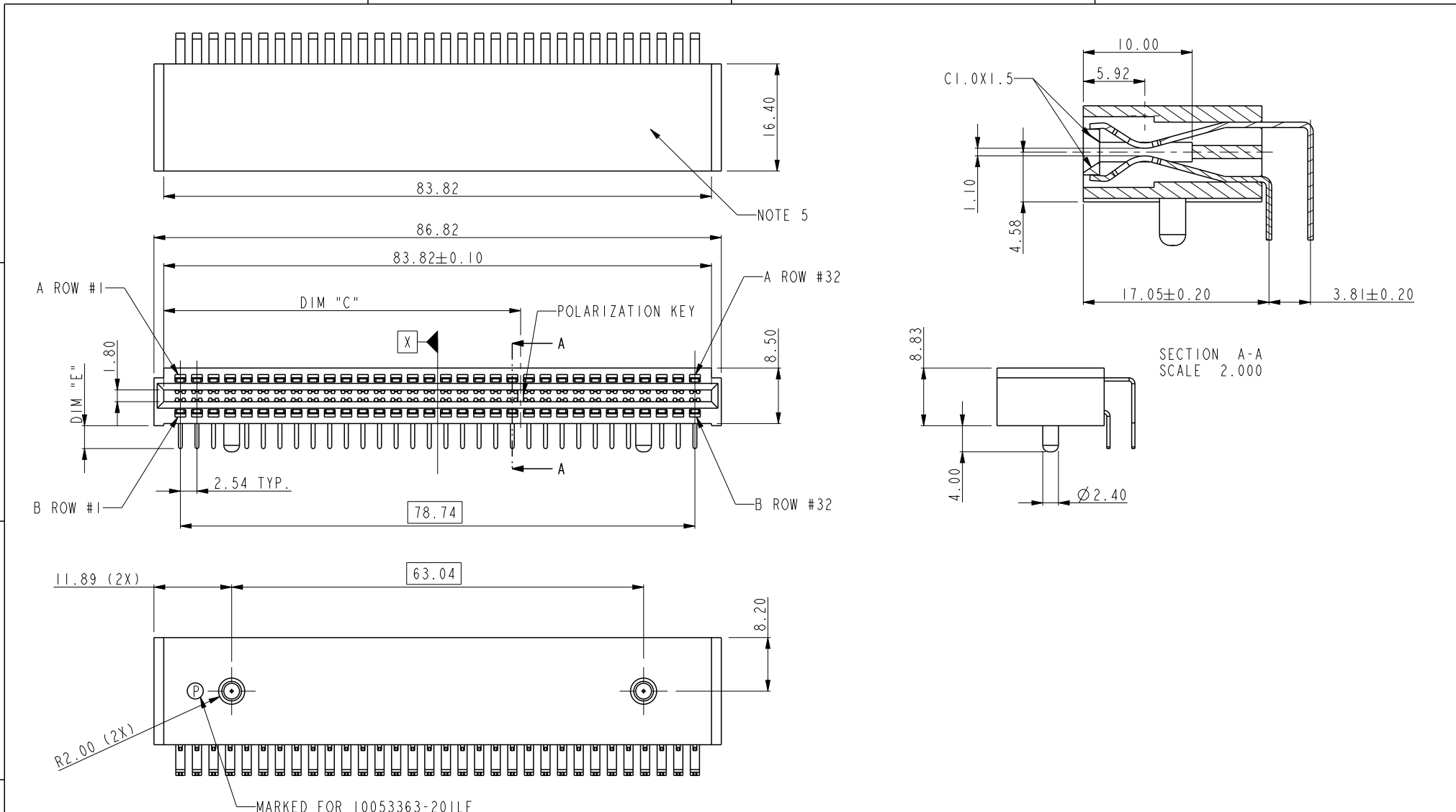

dr	wcadmin	2006/08/07	projection 	MM ←→	size	A4	scale	1.000
eng	Wei-Long Zhang	2012/06/06			ecn no	ELX-DG-011840-1		
chr	-	-			rel level	Released		
appr	Pei-Ming Zheng	2012/06/06	product family		dwg no		10053363	
www.fci.com		title		2X32P RIGHT ANGLE POWER CARD EDGE		rev		K
cat. no.		*		Product - Customer Drw		sheet 2 of 3		

PrdE File - REV C - 2009-06-09



Copyright FCI.

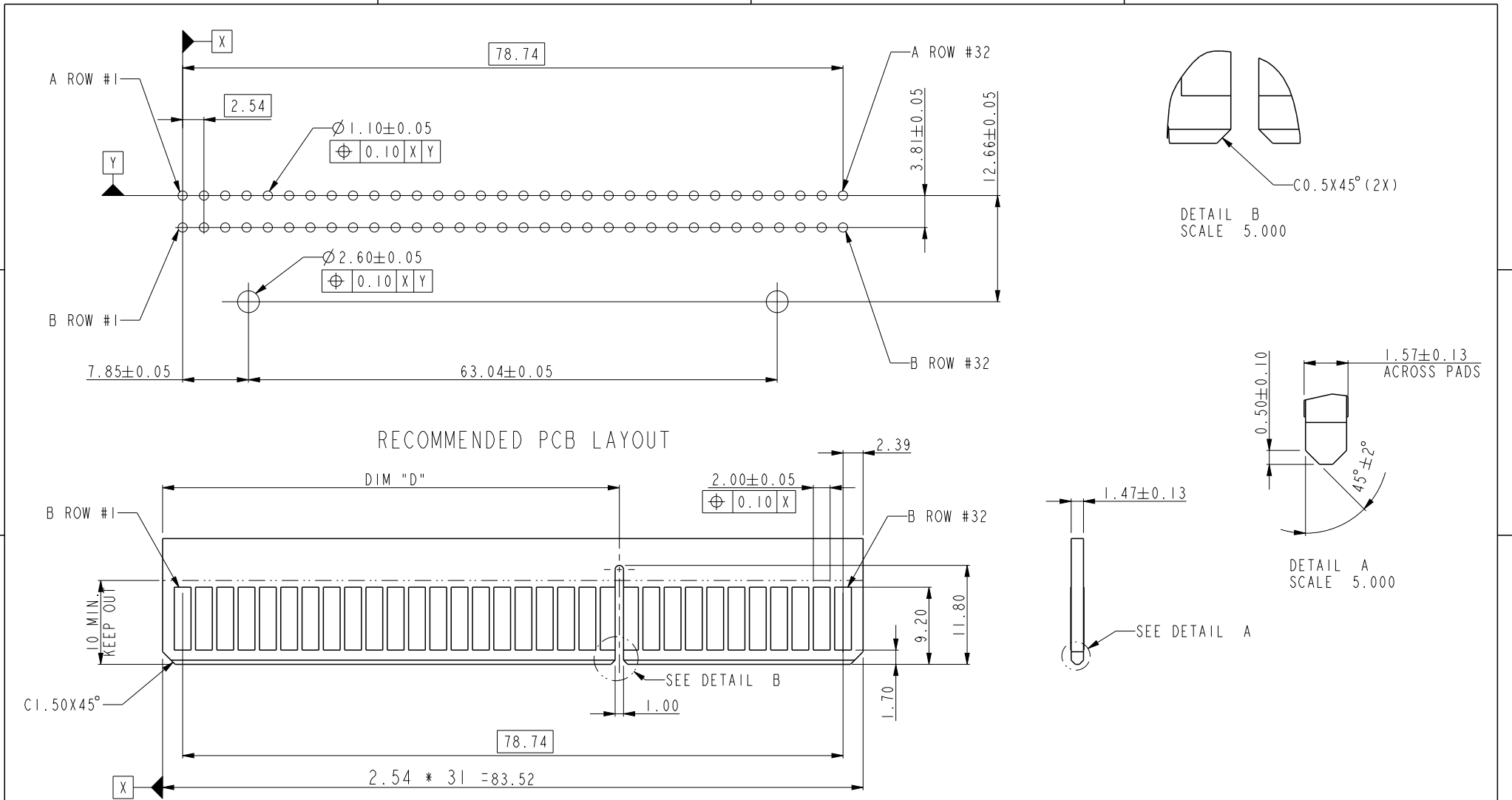

RECOMMENDED DAUGHTER CARD LAYOUT (TOP SIDE)

dr	wcadmin	2006/08/07	projection 	MM ←→	size	A4	scale	1.000
eng	Wei-Long Zhang	2012/06/06			ecn no	ELX-DG-011840-1		
chr	-	-			rel level	Released		
appr	Pei-Ming Zheng	2012/06/06	product family					
		title			2X32P RIGHT ANGLE		dwg no	
www.fci.com		cat. no.			*		10053363	
					Product - Customer Drw		rev	
							K	
					sheet 3 of 3			

ProjE File - REV C - 2009-06-09