

Type 2 surge protection plug - VAL-MS 400 ST - 2816399

Please be informed that the data shown in this PDF Document is generated from our Online Catalog. Please find the complete data in the user's documentation. Our General Terms of Use for Downloads are valid (<http://phoenixcontact.com/download>)



Surge protection connector type 2 with high-capacity varistor for VAL-MS base element, thermal monitoring, visual fault warning. Design: 400 V AC

Your advantages

- ✓ Single-channel, DIN-rail mountable protective devices
- ✓ Mechanical coding of all slots
- ✓ Optical, mechanical status indication for the individual arresters
- ✓ Disconnect device on each individual plug
- ✓ Consists of base element and plug
- ✓ Base element with/without floating remote indication contact



Key Commercial Data

Packing unit	10 pc
GTIN	 4 017918 131593
GTIN	4017918131593

Technical data

Dimensions

Height	52.4 mm
Width	17.5 mm
Depth	55.3 mm
Horizontal pitch	1 Div.

Ambient conditions

Degree of protection	IP20
Ambient temperature (operation)	-40 °C ... 80 °C
Ambient temperature (storage/transport)	-40 °C ... 80 °C
Altitude	≤ 2000 m (amsl (above mean sea level))

Type 2 surge protection plug - VAL-MS 400 ST - 2816399

Technical data

Ambient conditions

Permissible humidity (operation)	5 % ... 95 %
Shock (operation)	25g (Half-sine / 11 ms / 3x ±X, ±Y, ±Z)
Vibration (operation)	5g (10 ... 500 Hz / 2.5 h / X, Y, Z)

General

IEC test classification	II
	T2
EN type	T2
IEC power supply system	TN
	TT
	IT
Mode of protection	L-N
	L-PE
	L-PEN
Mounting type	on base element
Color	jet black RAL 9005
Housing material	PA 6.6
Degree of pollution	2
Flammability rating according to UL 94	V-0
Type	DIN rail module, two-section, divisible
Number of positions	1
Arrester can be tested with CHECKMASTER from software version:	From SW rev. 1.10
Surge protection fault message	optical

Additional descriptions

Note	Usable in all low-voltage systems between L-N or L-PEN. Only usable in IT Systems between L-PE, if the exposed-conductive-parts (bodies) of the equipment of the low-voltage installation is connected to the earthing arrangement of the transformer substation. (interconnected earthing arrangement of the HV-transformer substation with the bodies of the LV-installation. $R_E = R_A$ accordance to IEC 60364-4-442 / VDE 0100-442 Fig. 44D / Example a)
------	---

Protective circuit

Nominal voltage U_N	240/415 V AC (TN)
	240/415 V AC (TT)
	230 V AC (IT)
Nominal frequency f_N	50 Hz (60 Hz)
Maximum continuous voltage U_C	440 V AC
Residual current I_{PE}	≤ 0.45 mA
Standby power consumption P_C	≤ 200 mVA
Nominal discharge current I_n (8/20) μ s	20 kA
Maximum discharge current I_{max} (8/20) μ s	40 kA
Short-circuit current rating I_{SCCR}	25 kA

Type 2 surge protection plug - VAL-MS 400 ST - 2816399

Technical data

Protective circuit

Voltage protection level U_p	≤ 2.2 kV
Residual voltage U_{res}	≤ 2.2 kV (at I_n)
	≤ 1.8 kV (at 10 kA)
	≤ 1.5 kV (at 5 kA)
	≤ 1.4 kV (at 3 kA)
TOV behavior at U_T	440 V AC (5 s / withstand mode)
	440 V AC (120 min / withstand mode)
Response time t_A	≤ 25 ns
Max. backup fuse with branch wiring	125 A (gG)

Connection data

Connection method	pluggable
-------------------	-----------

UL specifications

SPD Type	4CA
Maximum continuous operating voltage MCOV (L-N)	440 V AC
Nom. voltage	400 V AC
Mode of protection	L-N
Power distribution system	Single phase
Nominal frequency	50/60 Hz
Measured limiting voltage MLV (L-N)	2280 V
Nominal discharge current I_n (L-N)	20 kA

Standards and Regulations

Standards/regulations	IEC 61643-11 2011
	EN 61643-11 2012

Environmental Product Compliance

China RoHS	Environmentally Friendly Use Period = 50
	For details about hazardous substances go to tab "Downloads", Category "Manufacturer's declaration"

Drawings

Type 2 surge protection plug - VAL-MS 400 ST - 2816399

Circuit diagram



Type 2 surge protection plug - VAL-MS 400 ST - 2816399

Dimensional drawing

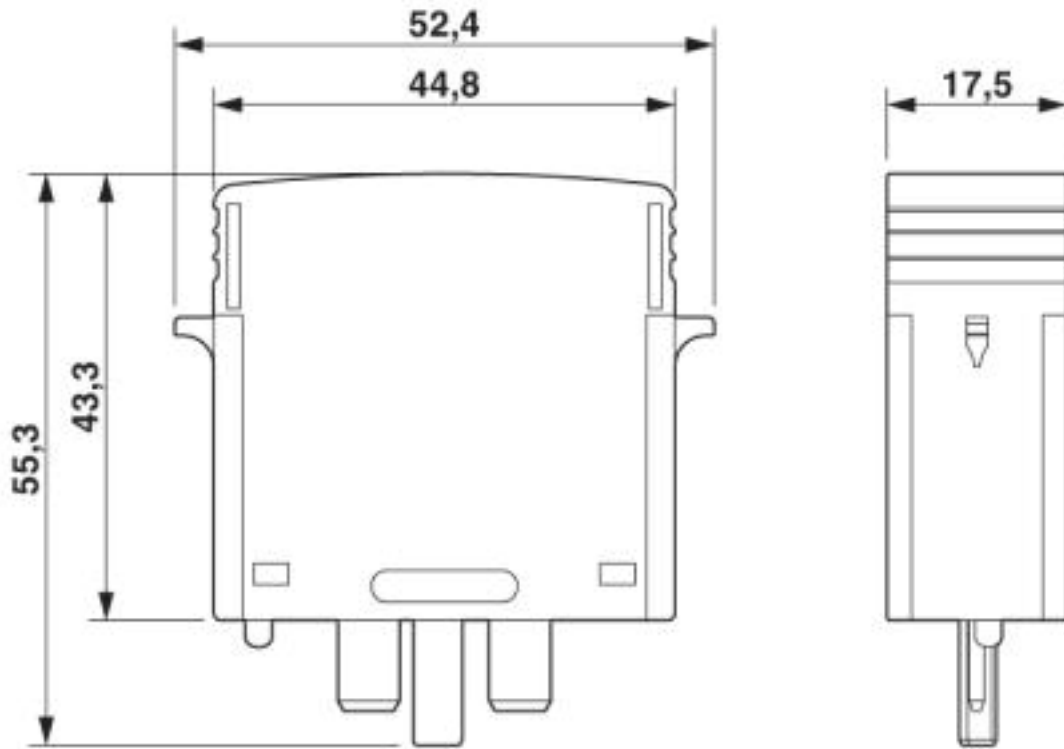

Approvals

Approvals

Approvals

CSA / GL / CCA / UL Recognized / KEMA-KEUR / cUL Recognized / IECCE CB Scheme / ÖVE / EAC / EAC / cULus Recognized

Ex Approvals

Approval details

CSA		http://www.csagroup.org/services-industries/product-listing/	13631
-----	--	---	-------

GL		https://approvalfinder.dnvgl.com/	94385-10 HH
----	--	---	-------------

CCA			NTR-AT 1947-A
-----	--	--	---------------

Type 2 surge protection plug - VAL-MS 400 ST - 2816399

Approvals

UL Recognized		http://database.ul.com/cgi-bin/XYV/template/LISEXT/1FRAME/index.htm	FILE E 330181
---------------	--	---	---------------

KEMA-KEUR		http://www.dekra-certification.com	2170208.01
-----------	--	---	------------

cUL Recognized		http://database.ul.com/cgi-bin/XYV/template/LISEXT/1FRAME/index.htm	FILE E 330181
----------------	--	---	---------------

IECEE CB Scheme		http://www.iecee.org/	AT 2905/M1
-----------------	--	---	------------

ÖVE		https://www.ove.at/zertifizierung-pz/zertifizierungsregister/	18583-001-14
-----	--	---	--------------

EAC			EAC-Zulassung
-----	--	--	---------------

EAC			RU C- DE.A*30.B01561
-----	--	--	-------------------------

cULus Recognized			
------------------	--	--	--

Phoenix Contact 2019 © - all rights reserved
<http://www.phoenixcontact.com>

PHOENIX CONTACT GmbH & Co. KG
Flachsmarktstr. 8
32825 Blomberg
Germany
Tel. +49 5235 300
Fax +49 5235 3 41200
<http://www.phoenixcontact.com>