



**AOS**  
**SEMICONDUCTOR**

## 产品规格说明书

Product Data Sheet

### LM2576HVS-5.0

WEB | [www.aossemi.cn](http://www.aossemi.cn) 



电源管理IC



通信接口芯片



二三极管



LDO稳压器



逻辑器件



MOSFETs



运算放大器



显示驱动



MCU单片机



光电器件

# LM2576HVS-5.0

## Data Sheet

### DC-DC Power Chip

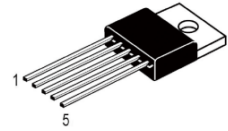

TO220T-5L

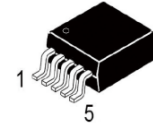

TO263-5L

## General Description

The LM2576HV series of regulators are monolithic integrated circuit that provides all the active functions for a step-down (buck) switching regulator, capable of driving 3A load with excellent line and load regulation. The LM2576 is available in fixed output voltages of 3.3V, 5V, 12V and an adjustable output version.

Requiring a minimum number of external components, these regulators are simple to use and include internal frequency compensation and a fixed-frequency oscillator.

The LM2576HV series offers a high-efficiency replacement for popular three-terminal linear regulators. It substantially reduces the size of the heat sink, and in some cases no heat sink is required. A standard series of inductors optimized for use with the LM2576 are available from several different manufacturers. This feature greatly simplifies the design of switch-mode power supplies.

Other features include a guaranteed  $\pm 4\%$  tolerance on output voltage within specified input voltages and output load conditions, and  $\pm 10\%$  on the oscillator frequency. External shutdown is included, featuring 50  $\mu\text{A}$  (typical) standby current. The output switch includes cycle-by-cycle current limiting, as well as thermal shutdown for full protection under fault conditions.

The LM2576HV is available in TO220T-5L and TO263-5L package.

## Features

- 3.3V, 5V, 12V and adjustable output versions
- High efficiency
- Guaranteed 3 A output current
- Requires only 4 external components
- 52 kHz fixed frequency internal oscillator
- TTL shutdown capability, low power standby mode
- Uses readily available standard inductors
- Thermal shutdown and current limit protection
- Adjustable version output voltage range, 1.23V to 37V  $\pm 4\%$  max over line and load conditions

## Application

- Simple high-efficiency step-down (buck) regulator
- Efficient pre-regulator for linear regulators
- On-card switching regulators
- Positive to negative converter (Buck-Boost)



# LM2576HVS-5.0

Data Sheet

Product Specification  
DC-DC Power Chip

## Functional Block Diagram

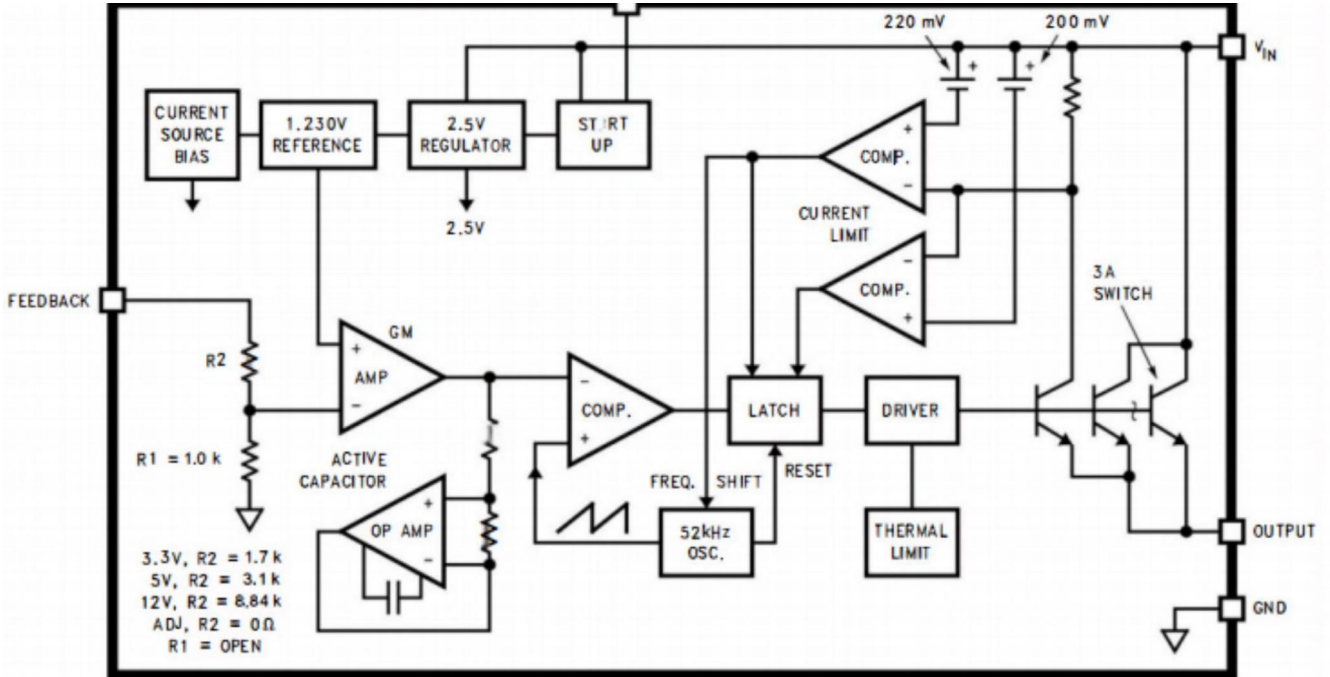

## Pin Configuration

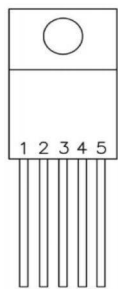

TO220T-5L

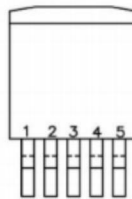

TO263-5L



Shanghai AOS Semiconductor Co. Ltd.

AOSSEMI

TEL: 400-7800-208

[www.aossemi.cn](http://www.aossemi.cn)

# LM2576HVS-5.0

## Data Sheet

### Pin Description

PinNumber	PinName	FunctionDescription
1	VIN	This is the positive input supply for the IC switching regulator. A suitable input bypass capacitor must be present at this pin to minimize voltage transients and to supply the switching currents needed by the regulator.
2	OUTPUT	Internal switch, the voltage at this pin switches between $(+V_{IN}V_{SAT})$ and approximately $-0.5V$ . To minimize coupling to sensitive circuitry, the PCB copper area connected to this pin should be kept to a minimum.
3	GND	Circuit Ground.
4	FEEDBACK	Senses the regulated output voltage to complete the feedback loop.
5	ON/OFF	Allows the switching regulator circuit to be shut down using logic level signals.

### Absolute Maximum Ratings

Parameter Name	Symbol	Value	Unit
Maximum Supply Voltage	$V_{IN}$	45	V
ON/OFF pin Input Voltage	ON/OFF	$-0.3 \leq V \leq +V_{IN}$	V
Output Voltage to Ground (steady state)	$V_{OUT}$	-1	V
Power Dissipation	$P_{DMAX}$	Internally Limited	
Storage Temperature Range	Tstg	-65~+150	
Maximum Junction Temperature	$T_{JA}$	150	°C
ESD Susceptibility(Human Body Model)	ESD	2	kV
Lead Temperature (Soldering,10 Second)	$T_L$	260	



## LM2576HVS-5.0

Data Sheet

## Electro-Optical Characteristics

(unless otherwise specified:  $T_j=25^{\circ}\text{C}$ )

Parameter	Symbol	Test Conditions	Min	Typ	Max	Units
Device Parameters						
Feedback Bias Current	$I_b$	Adjustable version only, $V_{OUT}=5V$		50	100	nA
Oscillator Frequency	$f_o$	(Note1)	47	52	58	kHz
VSAT Saturation Voltage	$V_{SAT}$	$I_{OUT}=3A$		1.4	1.8	V
Max.Duty Cycle(ON)	DC		93	98		%
Current Limit	$I_{CL}$	(Note1)	4.2	5.8	6.9	A
Output Leakage CurrentmA	$I_L$	Output=0V			2	mA
		Output=-1V			30	mA
Quiescent Current	$I_Q$				10	mA
Standby Quiescent Current	$I_{STBY}$	ON/OFF			200	$\mu\text{A}$
ON/OFF Control						
ON/OFF Pin Logic Input Level	$V_{IH}$	$V_{OUT}=0V$	2.0			V
	$V_{IL}$	$V_{OUT}=\text{nominal output voltage}$			0.8	V
ON/OFF Pin Input Current	$I_{IH}$	ON/OFF pin=5V (OFF)		12	30	$\mu\text{A}$
	$I_{IL}$	ON/OFF pin=0V (ON)		0	10	$\mu\text{A}$

**Note1:**The oscillator frequency reduces to approximately 11 kHz in the event of an output short or an overload which causes the regulated output voltage to drop approximately 40% from the nominal output voltage. This self protection feature lowers the average power dissipation of the IC by lowering the minimum duty cycle from 59% down to approximately 2%. Output pin sourcing current. No diode, inductor or capacitor connected to output.



## LM2576HVS-5.0

## Data Sheet

ParameterName	Symbol	Test Conditions	Min	Typ	Max	Units
LM2576-3.3V						
Output Voltage	V <sub>OUT</sub>	V <sub>IN</sub> =12V, I <sub>O</sub> =500mA	3.234	3.3	3.366	V
		6V ≤ V <sub>IN</sub> ≤ 40V 0.5A ≤ I <sub>LOAD</sub> ≤ 3A	3.168	3.3	3.450	V
Efficiency	η	V <sub>IN</sub> =12V, I <sub>LOAD</sub> =3A		75		%
LM2586-5.0V						
Output Voltage	V <sub>OUT</sub>	V <sub>IN</sub> =12V, I <sub>O</sub> =500mA	4.90	5.00	5.10	V
		8V ≤ V <sub>IN</sub> ≤ 40V 0.5A ≤ I <sub>LOAD</sub> ≤ 3A	4.80	5.00	5.20	V
Efficiency	η	V <sub>IN</sub> =12V, I <sub>LOAD</sub> =3A		77		%
LM2576-12V						
Output Voltage	V <sub>OUT</sub>	V <sub>IN</sub> =25V, I <sub>O</sub> =500mA	11.76	12.00	12.24	V
		15V ≤ V <sub>IN</sub> ≤ 40V 0.5A ≤ I <sub>LOAD</sub> ≤ 3A	11.52	12.00	12.48	V
Efficiency	η	V <sub>IN</sub> =25V, I <sub>LOAD</sub> =3A		88		%

ParameterName	Symbol	Test Conditions	Min	Typ	Max	Units
LM2576-ADJ						
Output Voltage	V <sub>OUT</sub>	V <sub>IN</sub> =12V, I <sub>O</sub> =500mA, V <sub>OUT</sub> =5V	1.217	1.230	1.243	V
		6V ≤ V <sub>IN</sub> ≤ 40V, V <sub>OUT</sub> =5V 0.5A ≤ I <sub>LOAD</sub> ≤ 3A	1.193	1.230	1.267	V
Efficiency	η	V <sub>IN</sub> =12V, I <sub>LOAD</sub> =3A, V <sub>OUT</sub> = 5V		77		%



# LM2576HVS-5.0

## Data Sheet

### Test Circuit

#### Fixed Output Voltage Versions

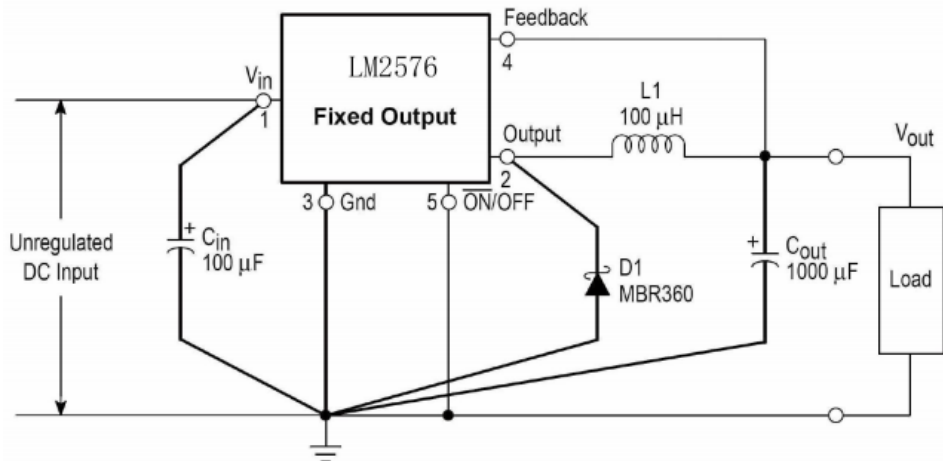

- $C_{in}$  - 100  $\mu$ F, 75 V, Aluminium Electrolytic
- $C_{out}$  - 1000  $\mu$ F, 25 V, Aluminium Electrolytic
- D1 - Schottky, MBR360
- L1 - 100  $\mu$ H, Pulse Eng. PE-92108
- R1 - 2.0 k, 0.1%
- R2 - 6.12 k, 0.1%

#### Adjustable output voltage versions

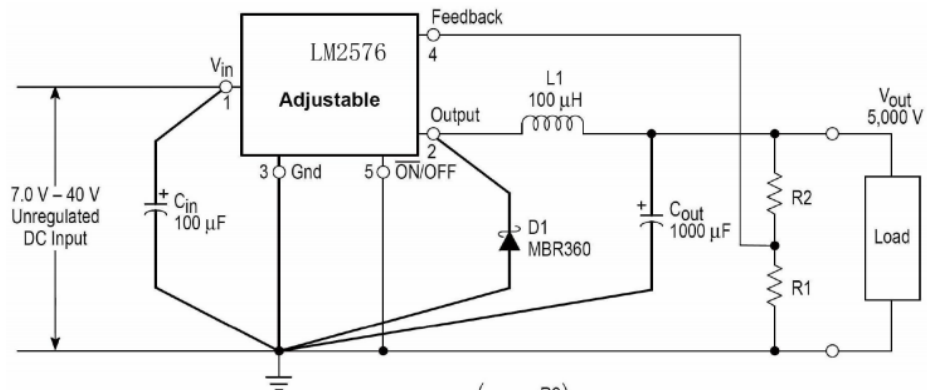

$$V_{out} = V_{ref} \left( 1.0 + \frac{R2}{R1} \right)$$

$$R2 = R1 \left( \frac{V_{out}}{V_{ref}} - 1.0 \right)$$

Where  $V_{ref} = 1.23$  V, R1 between 1.0 k and 5.0 k



## LM2576HVS-5.0

## Data Sheet

## Typical Application

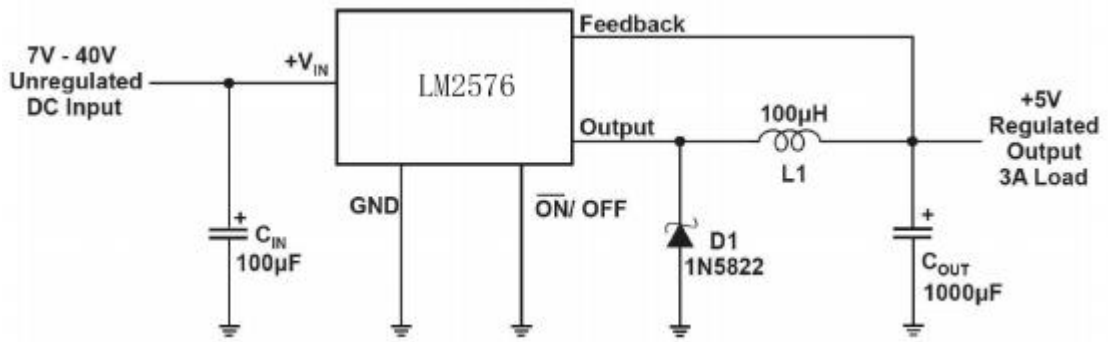

## Application Information

Input Capacitor( $C_{IN}$ )

To maintain stability, the regulator input pin must be bypassed with at least a 100 uF electrolytic capacitor.

The capacitor's leads must be kept short, and located near the regulator. If the operating temperature range includes temperatures below  $-25^{\circ}\text{C}$ , the input capacitor value may need to be larger. With most electrolytic capacitors, the capacitance value decreases and the ESR increases with lower temperatures and age. Paralleling a ceramic or solid tantalum capacitor will increase the regulator stability at cold temperatures. For maximum capacitor operating lifetime, the capacitor's RMS ripple current rating should be greater than

$$1.2 \times \left( \frac{t_{ON}}{T} \right) \times I_{LOAD}$$

$$\text{Where } \frac{t_{ON}}{T} = \frac{V_{OUT}}{V_{IN}}$$

$$\text{and } \frac{t_{ON}}{T} = \frac{|V_{OUT}|}{|V_{OUT}| + V_{IN}}$$



# LM2576HVS-5.0

## Data Sheet

### Inductor Selection

All switching regulators have two basic modes of operation: continuous and discontinuous. The difference between the two types relates to the inductor current, whether it is flowing continuously, or if it drops to zero for a period of time in the normal switching cycle. Each mode has distinctively different operating characteristics, which can affect the regulator performance and requirements. The LM2576 can be used for both continuous and discontinuous modes of operation. When using inductor values shown in the inductor selection guide, the peak-to-peak inductor ripple current will be approximately 20% to 30% of the maximum DC current. With relatively heavy load currents, the circuit operates in the continuous mode (inductor current always flowing), but under light load conditions, the circuit will be forced to the discontinuous mode (inductor current falls to zero for a period of time). This discontinuous mode of operation is perfectly acceptable. For light loads (less than approximately 300mA) it may be desirable to operate the regulator in the discontinuous mode, primarily because of the lower inductor values required for the discontinuous mode. The selection guide chooses inductor values suitable for continuous mode operation, but if the inductor value chosen is prohibitively high, the designer should investigate the possibility of discontinuous operation.

Inductors are available in different styles such as pot core, toroid, E-frame, bobbin core, etc., as well as different core materials, such as ferrites and powdered iron. The least expensive, the bobbin core type, consists of wire wrapped on a ferrite rod core. This type of construction makes for an inexpensive inductor, but since the magnetic flux is not completely contained within the core, it generates more electromagnetic interference (EMI).

This EMI can cause problems in sensitive circuits, or can give incorrect scope readings because of induced voltages in the scope probe. The inductors listed in the selection chart include ferrite pot core construction for AIE, powdered iron toroid for Pulse Engineering, and ferrite bobbin core for Renco.

An inductor should not be operated beyond its maximum rated current because it may saturate. When an inductor begins to saturate, the inductance decreases rapidly and the inductor begins to look mainly resistive (the DC resistance of the winding). This will cause the switch current to rise very rapidly. Different inductor types have different saturation characteristics and this should be kept in mind when selecting an inductor.



# LM2576HVS-5.0

## Data Sheet

The inductor manufacturer's data sheets include current and energy limits to avoid inductor saturation.

### Inductor Ripple Current

When the switcher is operating in the continuous mode, the inductor current waveform ranges from a triangular to a sawtooth type of waveform (depending on the input voltage). For a given input voltage and output voltage, the peak-to-peak amplitude of this inductor current waveform remains constant. As the load current rises or falls, the entire sawtooth current waveform also rises or falls. The average DC value of this waveform is equal to the DC load current (in the buck regulator configuration). If the load current drops to a low enough level, the bottom of the sawtooth current waveform will reach zero, and the switcher will change to a discontinuous mode of operation. This is a perfectly acceptable mode of operation. Any buck switching regulator (no matter how large the inductor value is) will be forced to run discontinuous if the load current is light enough.

### Catch Diode

Buck regulators require a diode to provide a return path for the inductor current when the switch is off. This diode should be located close to the LM2576 using short leads and short printed circuit traces.

Because of their fast switching speed and low forward voltage drop, Schottky diodes provide the best efficiency, especially in low output voltage switching regulators (less than 5V). Fast-Recovery, High-Efficiency, or Ultra-Fast Recovery diodes are also suitable, but some types with an abrupt turn-off characteristic may cause instability and EMI problems. A fast-recovery diode with soft recovery characteristics is a better choice. Standard 60 Hz diodes (e.g., IN4001 or IN5400, etc.) are also not suitable.

### Output Capacitor

An output capacitor is required to filter the output voltage and is needed for loop stability. The capacitor should be located near the LM2576 using short pc board traces. Standard aluminum electrolytics are usually adequate, but low ESR types are recommended for low output ripple voltage and good stability. The ESR of a capacitor depends on many factors, some which are: the value, the voltage rating, physical size and the type of construction. In general, low value or low voltage (less than 12V) electrolytic capacitors usually have higher ESR numbers.

The amount of output ripple voltage is primarily a function of the ESR (Equivalent Series Resistance) of the output capacitor and the amplitude of the inductor ripple current ( $\Delta I_{in}$ ). See the section on inductor ripple current in Application Hints. The lower capacitor values (220  $\mu$ F-1000  $\mu$ F) will allow typically 50 mV to 150 mV of output ripple voltage, while larger-value capacitors will reduce the ripple to approximately 20 mV to 50 mV. Output Ripple Voltage = ( $\Delta I_{in}$ ) (ESR of Cap). To further reduce the output ripple voltage, several standard electrolytic capacitors may be paralleled, or a higher-grade capacitor may be used. Such capacitors are often called



## LM2576HVS-5.0

### Data Sheet

“ high-frequency” “ low-inductance” or “ low-ESR” These will reduce the output ripple to 10 mV or 20 mV. However, when operating in the continuous mode, reducing the ESR below 0.032 can cause instability in the regulator.

Tantalum capacitors can have a very low ESR, and should be carefully evaluated if it is the only output capacitor. Because of their good low temperature characteristics, a tantalum can be used in parallel with aluminum electrolytics, with the tantalum making up 10% or 20% of the total capacitance. The capacitor's ripple current rating at 52 kHz should be at least 50% higher than the peak-to-peak inductor ripple current.

### Output Voltage Ripple and Transients

The output voltage of a switching power supply will contain a sawtooth ripple voltage at the switcher frequency, typically about 1% of the output voltage, and may also contain short voltage spikes at the peaks of the sawtooth waveform. The output ripple voltage is due mainly to the inductor sawtooth ripple current multiplied by the ESR of the output capacitor. The voltage spikes are present because of the fast switching action of the output switch, and the parasitic inductance of the output filter capacitor. To minimize these voltage spikes, special low inductance capacitors can be used, and their lead lengths must be kept short. Wiring inductance, stray capacitance, as well as the scope probe used to evaluate these transients, all contribute to the amplitude of these spikes. An additional small LC filter (20  $\mu$ H & 100  $\mu$ F) can be added to the output to further reduce the amount of output ripple and transients. A 10 x reduction in output ripple voltage and transients is possible with this filter.

### Feedback Connection

The LM2576(fixed voltage versions)feedback pin must be wired to the output voltage point of the switching power supply. When using the adjustable version, physically locate both output voltage programming resistors near the LM2576 to avoid picking up unwanted noise. Avoid using resistors greater than 100k because of the increased chance of noise pickup. **ON/OFF Input**

For normal operation, the ON /OFF pin should be grounded or driven with a low-level TTL voltage (typically below 1.6V). To put the regulator into standby mode, drive this pin with a high-level TTL or CMOS signal. The ON/OFF pin can be safely pulled up to +V<sub>in</sub> without a resistor in series with it. The ON/OFF pin should not be left open.



# LM2576HVS-5.0

## Data Sheet

### Inductor Value Selection Guides ( For Continuous Mode Operation)

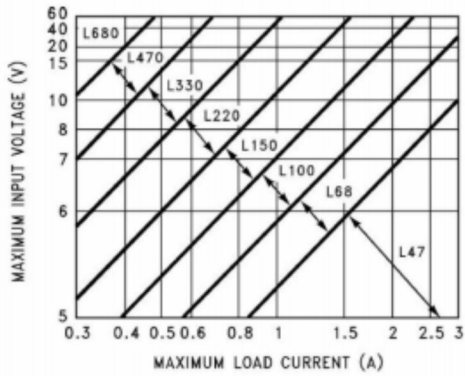

LM2576HV-3.3

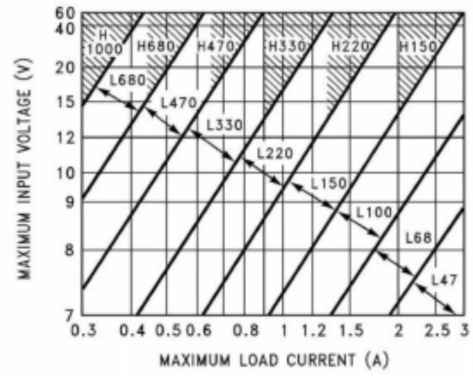

LM2576HV-5.0

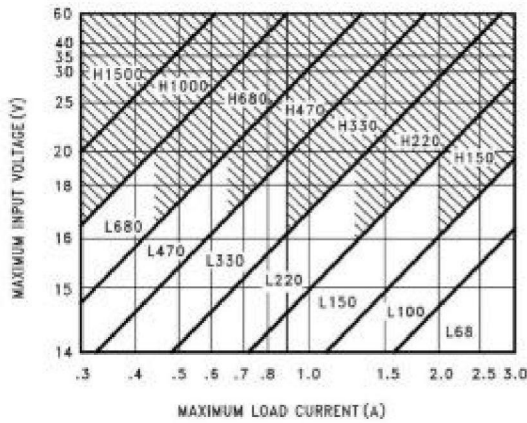

LM2576HV-12

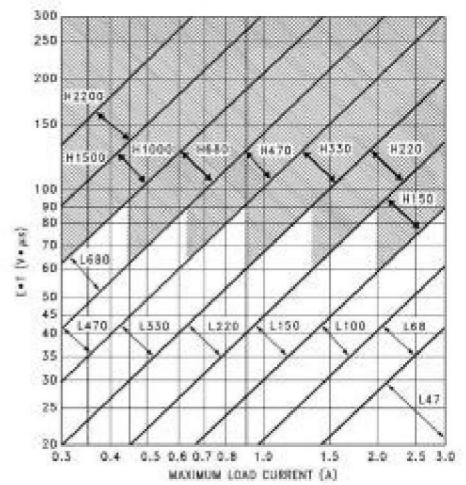

LM2576HV-ADJ



# LM2576HVS-5.0

## Data Sheet

Inductor Code	Inductor Value	Schott	PulseEng.	Renco
L47	47μH	67126980	PE-53112	RL2442
L48	68μH	67126990	PE-92114	RL2443
L100	100μH	67127000	PE-92108	RL2444
L150	150μH	67127010	PE-53113	RL1954
L220	220μH	67127020	PE-52626	RL1953
L330	330μH	67127030	PE-52627	RL1952
L470	470μH	67127040	PE-53114	RL1951
L680	680μH	67127050	PE-52629	RL1950
H150	150μH	67127060	PE-53115	RL2245
H220	220μH	67127070	PE-53116	RL2446
H330	330μH	67127080	PE-53117	RL2447
H470	470μH	67127090	PE-53118	RL1961
H680	680μH	67127100	PE-53119	RL1960
H1000	1000μH	67127110	PE-53120	RL1959
H1500	1500μH	67127120	PE-53121	RL1958
H2200	2200μH	67127130	PE-53122	RL2448

### Inductor Selection Guide



## LM2576HVS-5.0

## Data Sheet

VR	Schottky		FastRecovery	
	3A	4A-6A	3A	4A-6A
20V	1N5820 MBR320P SR302	1N5823	The following diodes are all rated to 100V  31DF1 HER302	The following diodes are all rated to 100V  50WF10 MUR410 HER602
30V	1N5821 MBR330 31DQ03 SR303	50WQ03 1N5824		
40V	1N5822 MBR340 31DQ04 SR304	MBR34050WQ04 1N5825		
50V	MBR350 31DQ05 SR305	50WQ05		
60V	MBR360 DQ06 SR306	50WR0650SQ060		

Diode selection Guide



# LM2576HVS-5.0

## Data Sheet

### Characteristic Curves

**NORMALIZED OUTPUT VOLTAGE**

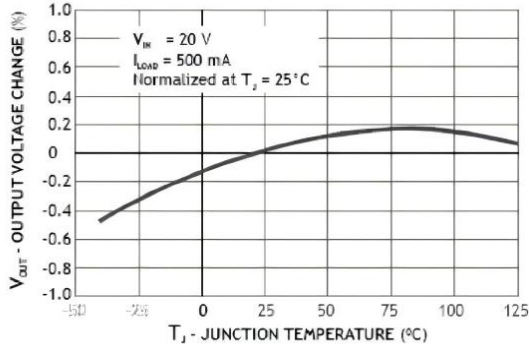

**LINE REGULATION**

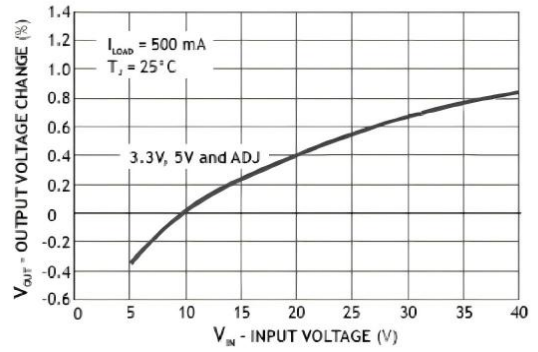

**OSCILLATOR FREQUENCY**

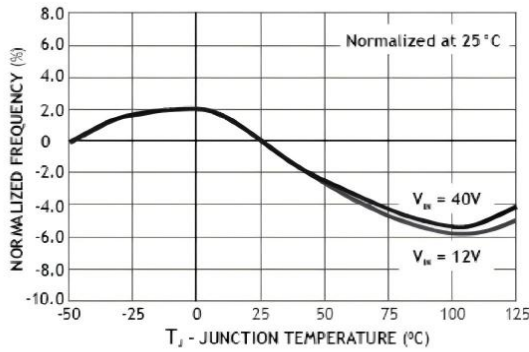

**CURRENT LIMIT**

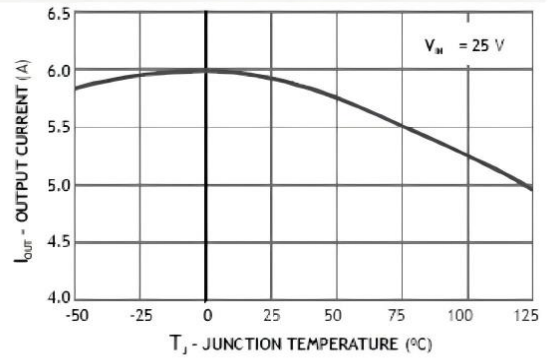

**QUIESCENT CURRENT**

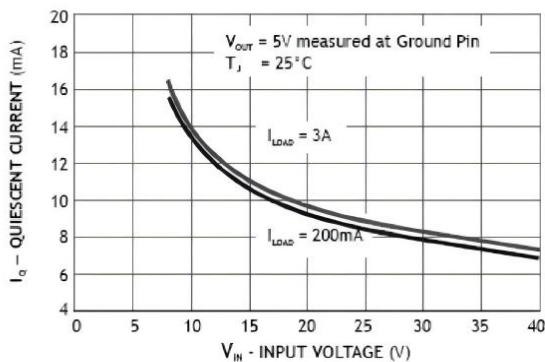

**MINIMUM OPERATING VOLTAGE**

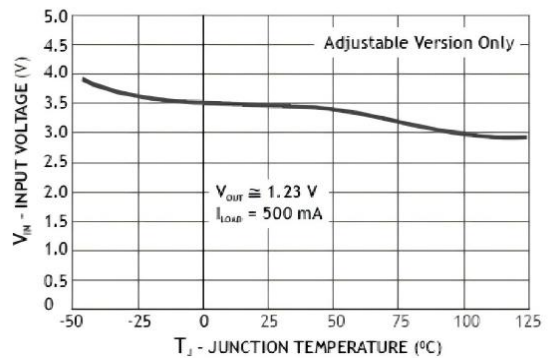

# LM2576HVS-5.0

## Data Sheet

### Outline dimensions

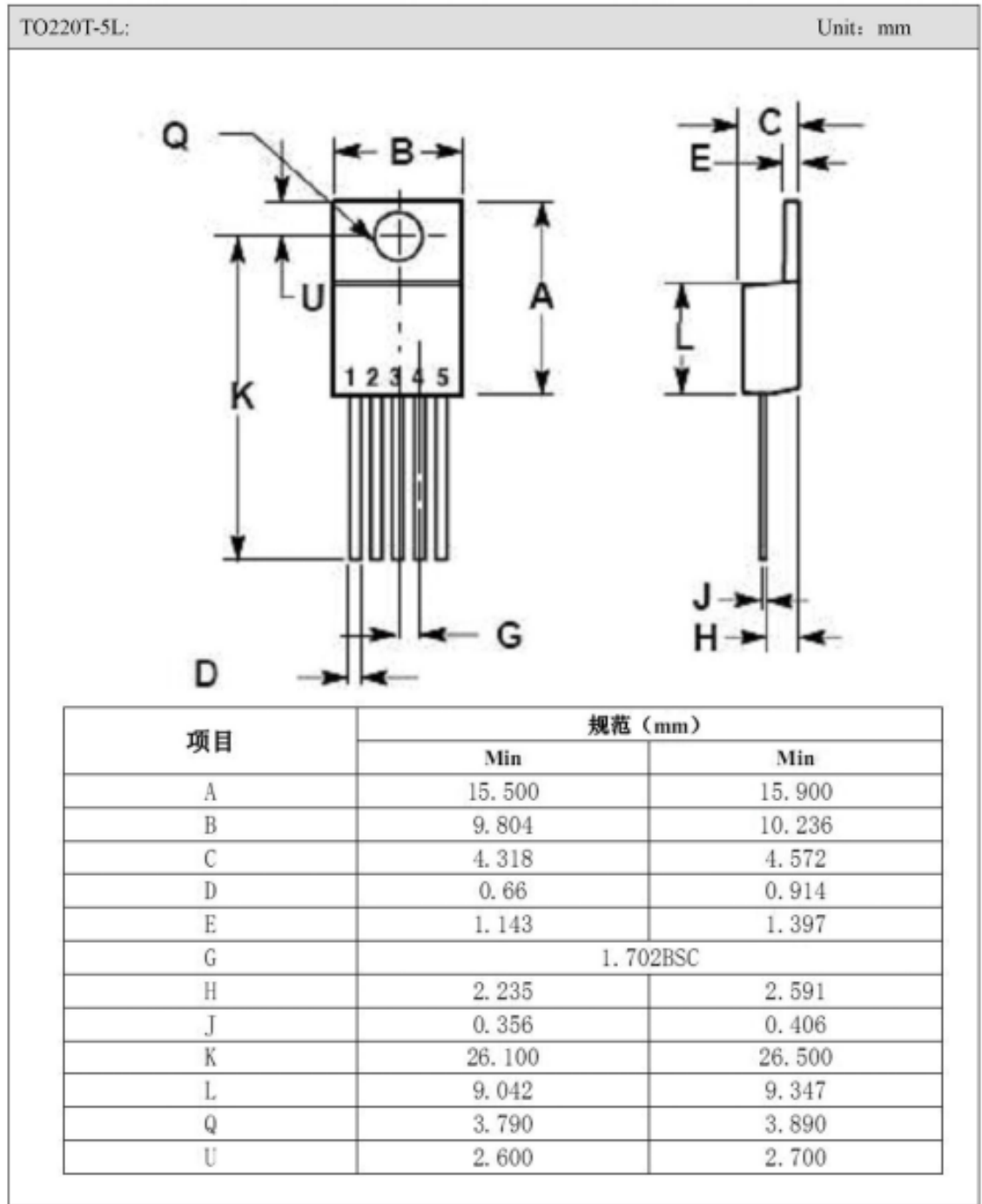

# LM2576HVS-5.0

## Data Sheet

Product Specification  
DC-DC Power Chip

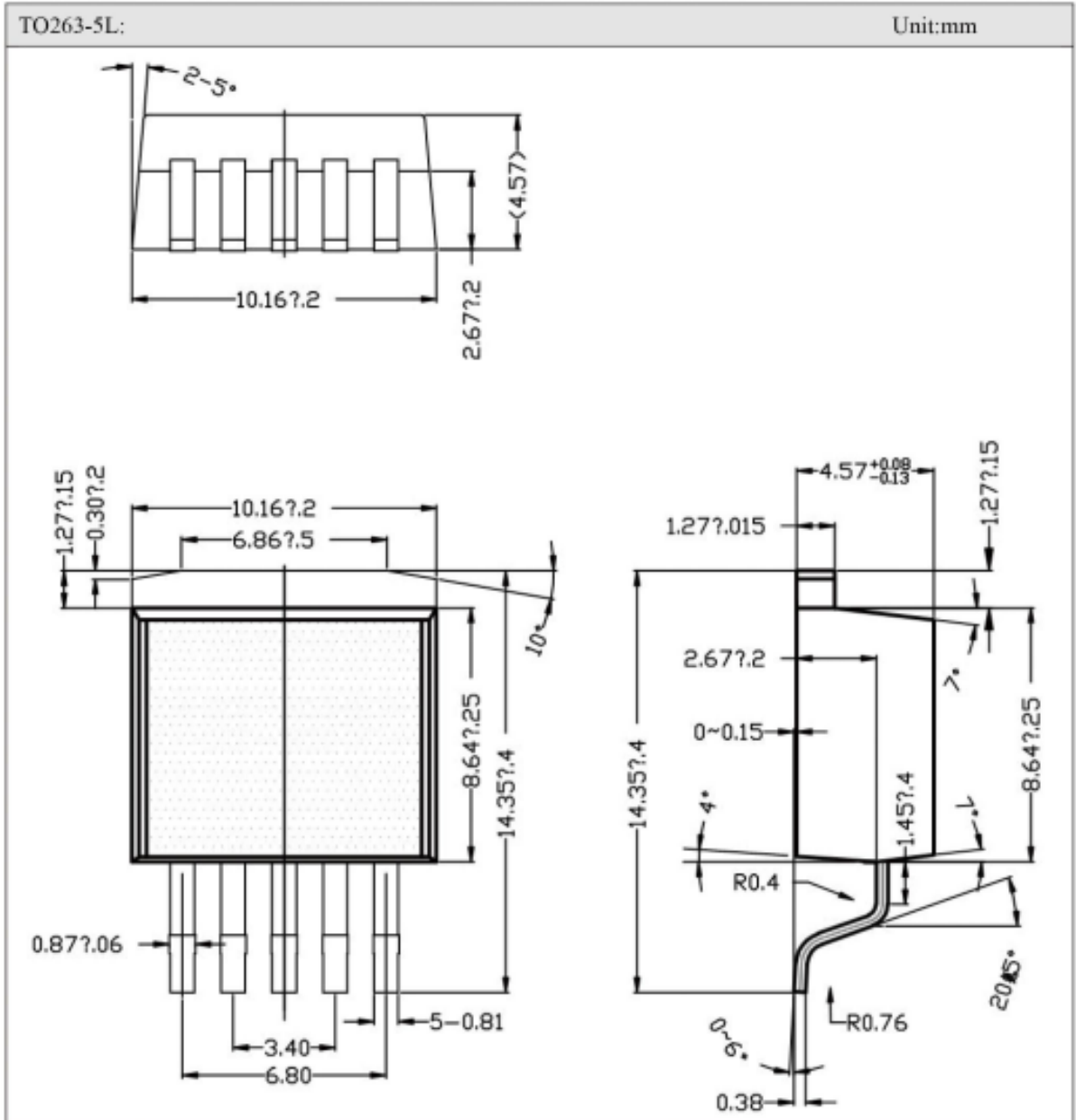

Shanghai AOS Semiconductor Co., Ltd.

AOSSEMI

TEL: 400-7800-208

[www.aossemi.cn](http://www.aossemi.cn)