

## 0.1-3.8GHz SP8T Switch for High Power Applications

### Features

- Broadband frequency range: 0.1 to 3.8 GHz
- Low insertion loss: 0.81dB typical @ 3.8 GHz
- High isolation: >20dB @ 3.8 GHz
- Integrated logic
- Small QFN (14-pin, 2.0mm x 2.0mm x 0.55mm) package

### Applications

- 2G/3G/4G antenna diversity and primary
- Cellular modems , tablets and USB Devices
- Other RF front-end modules

### General Description

The AW13418TQNR is a SP8T switch with low insertion loss and high Isolation. It can be used to support band switching and mode switching in antenna diversity systems for 2G/3G/4G, data cards and tablets.

The symmetrical design of internal ports makes it convenient for PCB routing and adjustment of receiving and transmitting signals. The band/mode switching is realized by the GPIO pins as referenced in the chip block diagram and the control logic.

The AW13418TQNR is provided in a compact 2.0mm x 2.0mm x 0.55mm, 14-pin QFN package.

### Typical Application Circuit

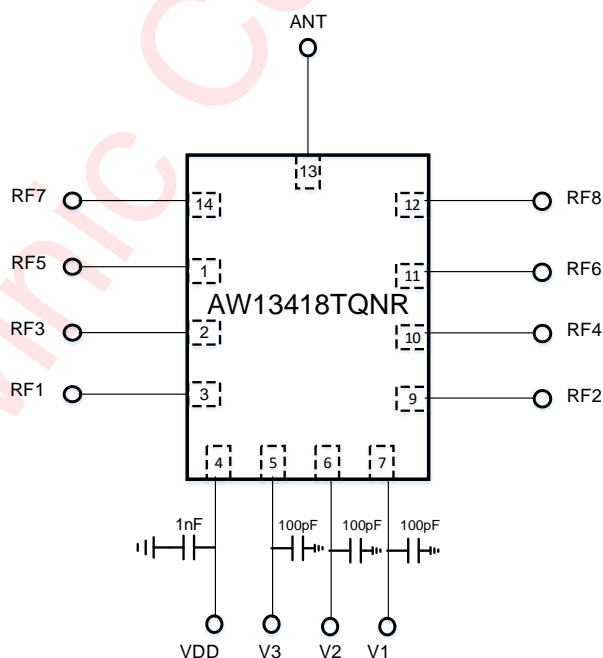

Figure 1 Typical Application Circuit of AW13418TQNR

All trademarks are the property of their respective owners.

## Pin Configuration And Top Mark

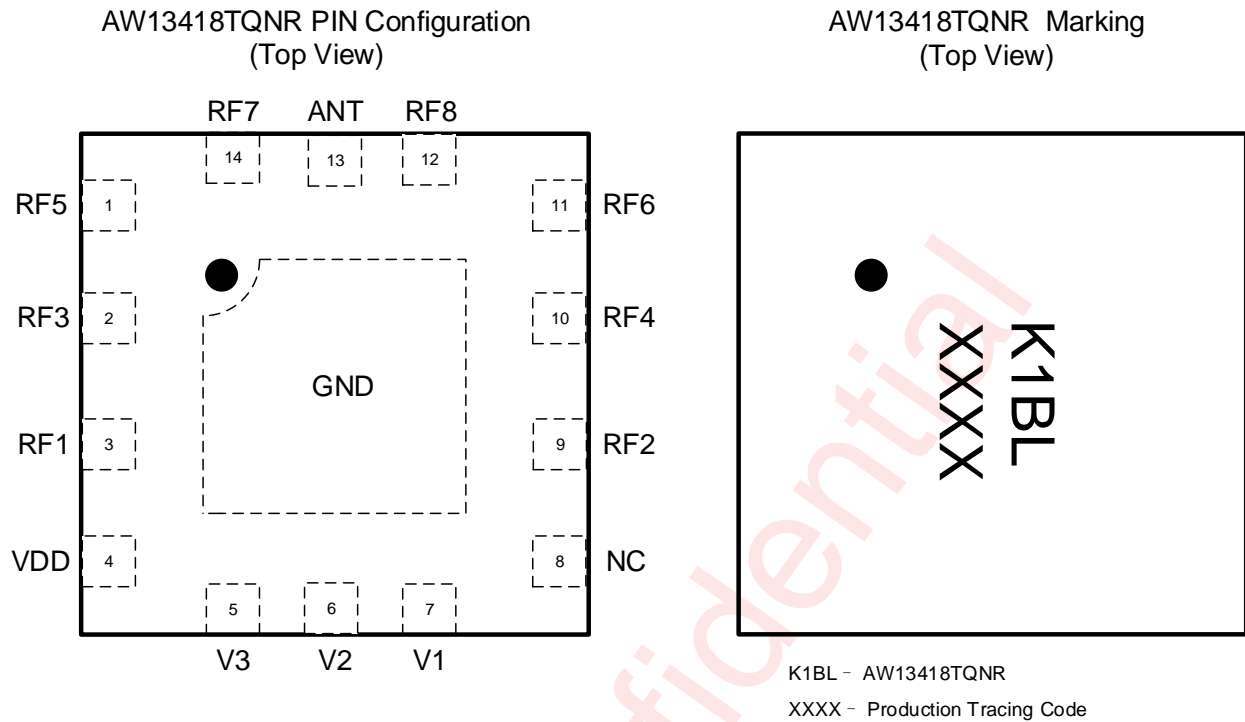

Figure 2 Pin Configuration and Top Mark

## Pin Definition

No.	NAME	DESCRIPTION
1	RF5	RF I/O path 5
2	RF3	RF I/O path 3
3	RF1	RF I/O path 1
4	VDD	DC power supply
5	V3	DC control voltage 3
6	V2	DC control voltage 2
7	V1	DC control voltage 1
8	NC	Not connected
9	RF2	RF I/O path 2
10	RF4	RF I/O path 4
11	RF6	RF I/O path 6
12	RF8	RF I/O path 8
13	ANT	Antenna port
14	RF7	RF I/O path 7

**Note: Bottom ground paddles must be connected to ground.**

## Functional Block Diagram

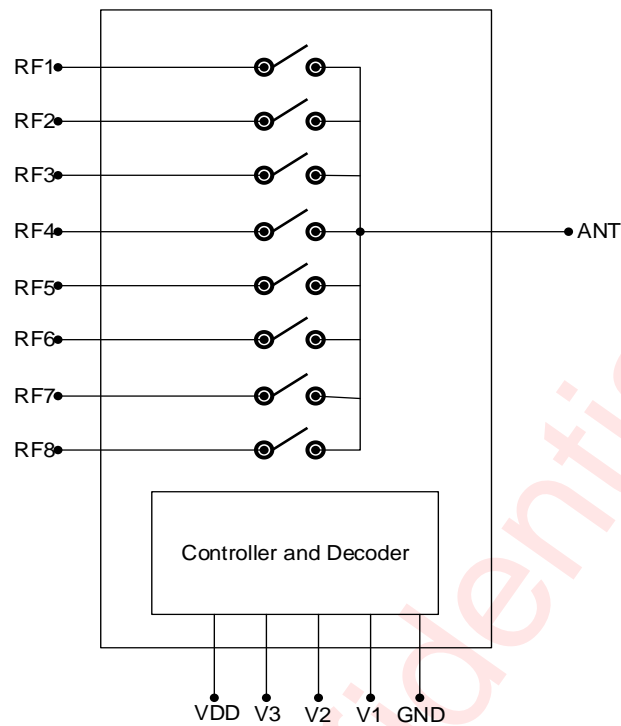
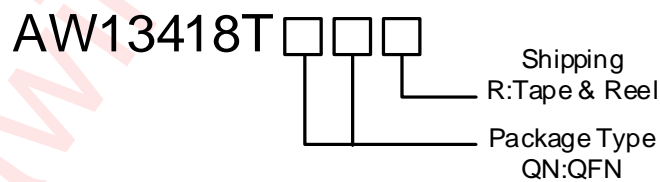

Figure 3 Functional Block Diagram

## Ordering Information

Part Number	Temperature	Package	Marking	Moisture Sensitivity Level	Environmental Information	Delivery Form
AW13418TQNR	-40°C~85°C	QFN 2mmX2mmX 0.55mm-14L	K1BL	MSL1	ROHS+HF	4500 units/ Tape and Reel



**Absolute Maximum Ratings**<sup>(NOTE1)</sup>

PARAMETERS		RANGE
Supply Voltage Range VDD		1.65V to 5V
Control Voltage Range	V1,V2,V3	0V to 3V
RF input power(RF1 to RF8)		37dBm
Operating Free-air Temperature Range		-40°C to 85°C
Storage Temperature T <sub>STG</sub>		-65°C to 150°C
Lead Temperature (Soldering 10 Seconds)		260°C
ESD		
HBM (NOTE 2)		±1kV
CDM (NOTE 3)		±500V

NOTE1: Conditions out of those ranges listed in "absolute maximum ratings" may cause permanent damages to the device. In spite of the limits above, functional operation conditions of the device should within the ranges listed in "recommended operating conditions". Exposure to absolute-maximum-rated conditions for prolonged periods may affect device reliability.

NOTE2: The human body model is a 100pF capacitor discharged through a 1.5kΩ resistor into each pin. Test method: ESDA/JEDEC JS-001-2017

NOTE3: All pins. Test Condition: ESDA/JEDEC JS-002-2018

**Electrical Characteristics**

VDD=2.8V, V1=V2=V3=0/1.8V, PIN=0dBm, Temp=+25°C, Z<sub>0</sub>=50Ω. (unless otherwise noted)

PARAMETER		TEST CONDITION	MIN	TYP	MAX	UNIT
<b>DC Specifications</b>						
VDD	Supply Voltage		1.65	2.8	5	V
IDD	Supply Current			43	80	μA
VCTL_H VCTL_L	Control Voltage High Low		0.9 0	1.2 0	3 0.3	V
ICTL	Control Current	VCTL = 1.8V		0.5	3	μA
tON	Turn-on Switching Time	50% of final control voltage to 90% of final RF power, switching between RF1/2/3/4/5/6/7/8		0.7	1	μS
<b>RF Specifications</b>						
IL	Insertion loss(ANT pin to RF1-RF8)	0.1-1.0G 1.0-2.0G 2.0-2.7G 2.7-3.8G		0.31 0.42 0.56 0.81	0.46 0.57 0.73 0.9	dB dB dB dB

PARAMETER		TEST CONDITION	MIN	TYP	MAX	UNIT
ISO	Isolation (ANT pin to RF1-RF8)	0.1-1.0G	30	40		dB
		1.0-2.0G	24	33		dB
		2.0-2.7G	20	27		dB
		2.7-3.8G	18	23		dB
RL	Input return loss (ANT pin to RF1-RF8)	0.1-1.0G	23	31		dB
		1.0-2.0G	18	25		dB
		2.0-2.7G	15	21		dB
		2.7-3.8G	10	15		dB
2fo	Second harmonics (ANT pin to RF1-RF8)	PIN=+26dBm, 0.1-3.8GHz		90		dBc
3fo	Third harmonics (ANT pin to RF1-RF8)	PIN=+26dBm, 0.1-3.8GHz		85		dBc
P <sub>0.1dB</sub>	0.1dB Compression Point (ANT pin to RF1-RF8)	0.1GHz-3.8GHz		37		dBm

## Timing Diagram (Power ON and OFF sequence)

It is very important that the user adheres to the correct power-on/off sequence in order to avoid damaging the device. The control signal V1, V2, V3 should be set to 0V unless VDD is set in the operating voltage range.

Power ON:

- 1) Apply voltage supply --- VDD
- 2) Set Controls---V1, V2, V3
- 3) Apply RF input

Change switch position from one RF port to another:

- 1) Remove RF input
- 2) Change control voltages V1, V2, V3 to set the switch to desired RF port
- 3) Apply RF input

Power OFF:

- 1) Remove RF input
- 2) Remove control voltages-V1, V2, V3
- 3) Remove VDD input

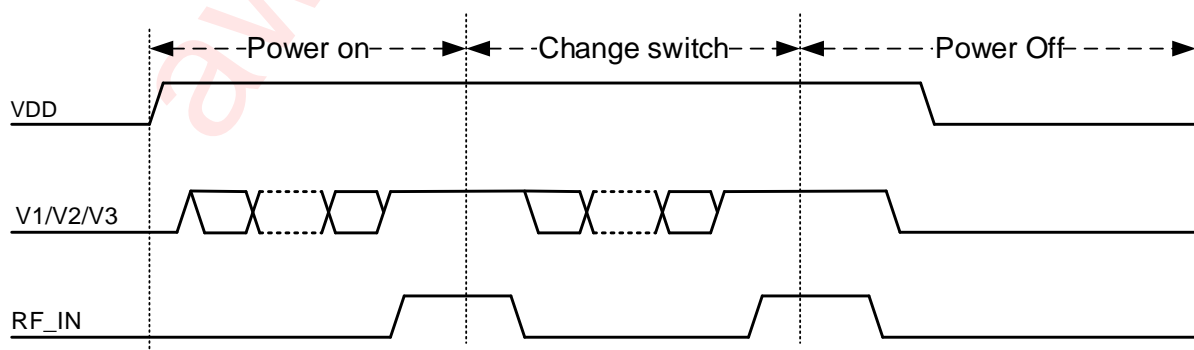
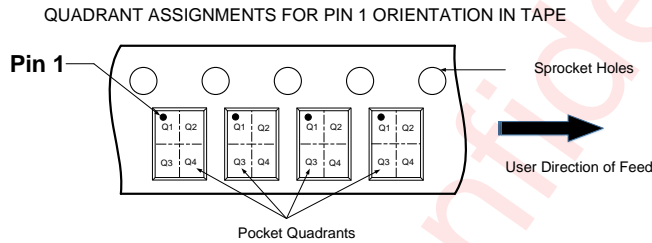
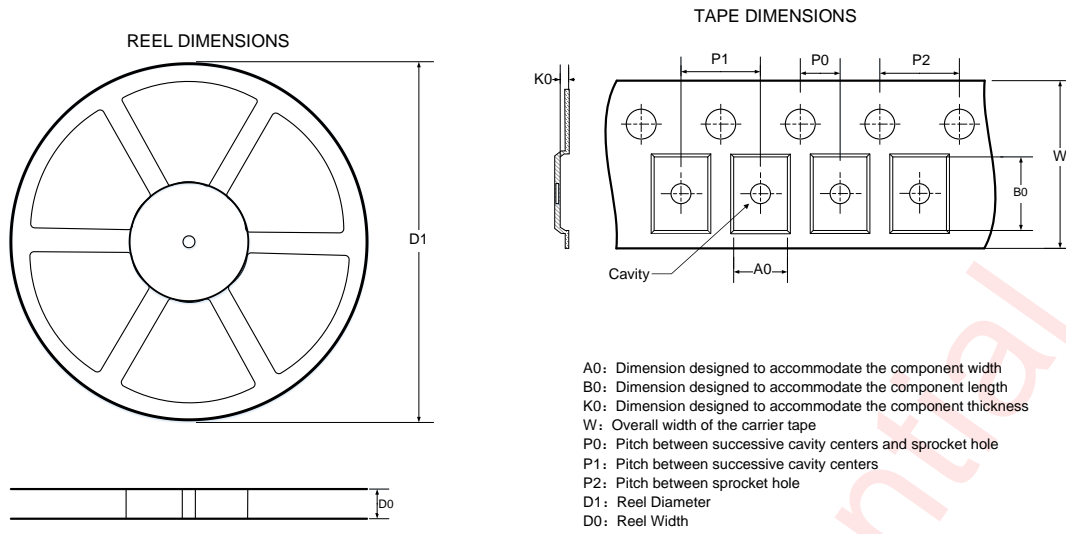

Figure 4 Power on/Change switch/Power off sequence

## AW13418TQNR Control Logic

Control Pins			Switch RF I/O							
V1	V2	V3	RF1	RF2	RF3	RF4	RF5	RF6	RF7	RF8
0	0	0	<b>ON</b>	Isolation	Isolation	Isolation	Isolation	Isolation	Isolation	Isolation
0	0	1	Isolation	<b>ON</b>	Isolation	Isolation	Isolation	Isolation	Isolation	Isolation
0	1	0	Isolation	Isolation	<b>ON</b>	Isolation	Isolation	Isolation	Isolation	Isolation
0	1	1	Isolation	Isolation	Isolation	<b>ON</b>	Isolation	Isolation	Isolation	Isolation
1	0	0	Isolation	Isolation	Isolation	Isolation	<b>ON</b>	Isolation	Isolation	Isolation
1	0	1	Isolation	Isolation	Isolation	Isolation	Isolation	<b>ON</b>	Isolation	Isolation
1	1	0	Isolation	Isolation	Isolation	Isolation	Isolation	Isolation	<b>ON</b>	Isolation
1	1	1	Isolation	Isolation	Isolation	Isolation	Isolation	Isolation	Isolation	<b>ON</b>

### Tape and Reel Information



Note: The above picture is for reference only. Please refer to the value in the table below for the actual size

DIMENSIONS AND PIN1 ORIENTATION

D1 (mm)	D0 (mm)	A0 (mm)	B0 (mm)	K0 (mm)	P0 (mm)	P1 (mm)	P2 (mm)	W (mm)	Pin1 Quadrant
180	8.4	2.25	2.25	0.75	2	4	4	8	Q1

All dimensions are nominal

Figure 5 Tape and Reel

## Package Description

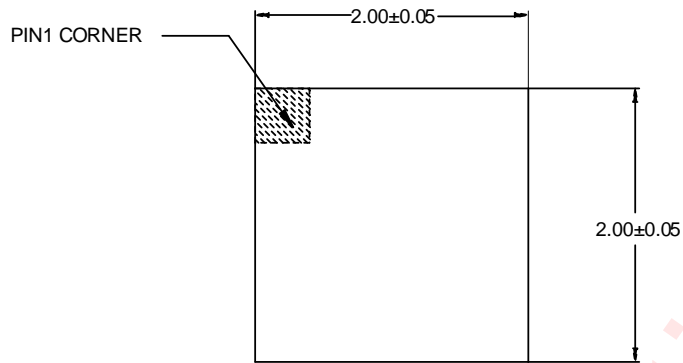

Top View



Side View

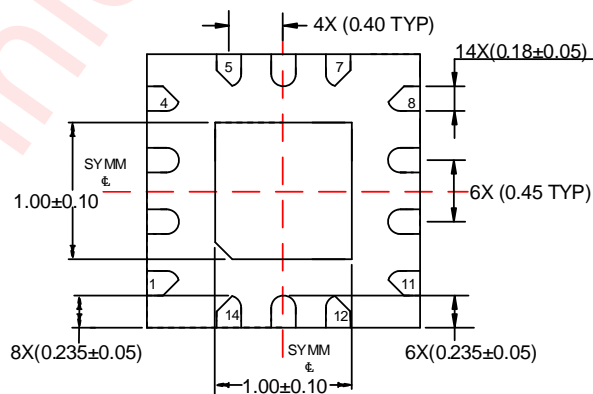

Bottom View

Unit: mm

Figure 6 Package Description



## Revision History

Vision	Date	Change Record
V1.0	Aug. 2021	Officially Released
V1.1	Aug. 2022	Update Ordering Information

awinic Confidential

## Disclaimer

Information in this document is believed to be accurate and reliable. However, Shanghai AWINIC Technology Co., Ltd (AWINIC Technology) does not give any representations or warranties, expressed or implied, as to the accuracy or completeness of such information and shall have no liability for the consequences of use of such information.

AWINIC Technology reserves the right to make changes to information published in this document, including without limitation specifications and product descriptions, at any time and without notice. Customers shall obtain the latest relevant information before placing orders and shall verify that such information is current and complete. This document supersedes and replaces all information supplied prior to the publication hereof.

AWINIC Technology products are not designed, authorized or warranted to be suitable for use in medical, military, aircraft, space or life support equipment, nor in applications where failure or malfunction of an AWINIC Technology product can reasonably be expected to result in personal injury, death or severe property or environmental damage. AWINIC Technology accepts no liability for inclusion and/or use of AWINIC Technology products in such equipment or applications and therefore such inclusion and/or use is at the customer's own risk.

Applications that are described herein for any of these products are for illustrative purposes only. AWINIC Technology makes no representation or warranty that such applications will be suitable for the specified use without further testing or modification.

All products are sold subject to the general terms and conditions of commercial sale supplied at the time of order acknowledgement.

Nothing in this document may be interpreted or construed as an offer to sell products that is open for acceptance or the grant, conveyance or implication of any license under any copyrights, patents or other industrial or intellectual property rights.

Reproduction of AWINIC information in AWINIC data books or data sheets is permissible only if reproduction is without alteration and is accompanied by all associated warranties, conditions, limitations, and notices. AWINIC is not responsible or liable for such altered documentation. Information of third parties may be subject to additional restrictions.

Resale of AWINIC components or services with statements different from or beyond the parameters stated by AWINIC for that component or service voids all express and any implied warranties for the associated AWINIC component or service and is an unfair and deceptive business practice. AWINIC is not responsible or liable for any such statements.