



Description

The HT24LC128 device is a 128K-bit 2-wire serial read/write non-volatile memory device manufactured using a CMOS floating gate process. Its 128K bits of memory are organized into 16K words and each word is 8 bits. The device is optimized for use in many industrial and commercial applications where low power and low voltage operation are essential. Up to eight HT24LC128 devices may be connected to the same two-wire bus. The HT24LC128 is guaranteed for 1M erase/write cycles and 40-year data retention.

Features

- Operating voltage: 2.2V~5.5V for temperature -40°C to +85°C
- Memory Capacity: 128K (16K×8)
- 2-wire I²C serial interface
- Write cycle time: 5ms max.
- Automatic erase-before-write operation
- Partial page write allowed
- 64-byte Page write modes
- Write operation with built-in timer
- Hardware controlled write protection
- 40-year data retention
- 10⁶ erase/write cycles per word
- 8-pin DIP/SOP(SOIC-8)/TSSOP package

Block Diagram

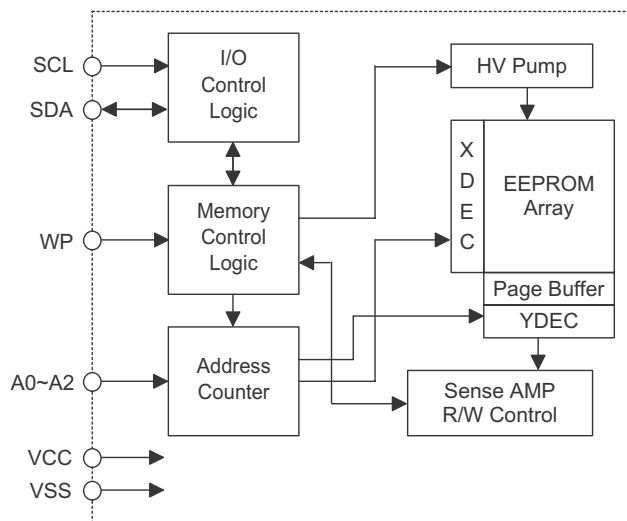

Pin Description And Assignment

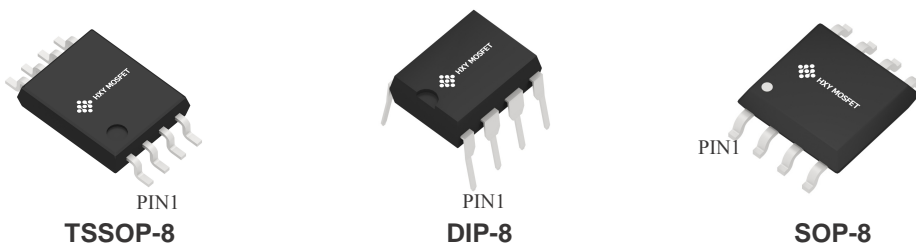

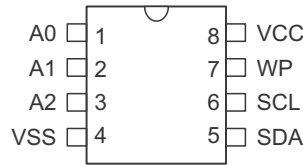

Pin Name	Type	Description
A0~A2	I	Address inputs
SDA	I/O	Serial data
SCL	I	Serial clock input
WP	I	Write protect
VSS	PWR	Negative power supply, ground
VCC	PWR	Positive power supply

Absolute Maximum Ratings

Supply Voltage $V_{SS}-0.3V$ to $V_{SS}+6.0V$ Storage Temperature $-50^{\circ}C$ to $125^{\circ}C$
 Input Voltage $V_{SS}-0.3V$ to $V_{CC}+0.3V$ Operating Temperature $-40^{\circ}C$ to $85^{\circ}C$

Note: These are stress ratings only. Stresses exceeding the range specified under “Absolute Maximum Ratings” may cause substantial damage to the device. Functional operation of this device at other conditions beyond those listed in the specification is not implied and prolonged exposure to extreme conditions may affect device reliability.

D.C Characteristics

$T_a = -40^{\circ}C$ to $85^{\circ}C$

Symbol	Parameter	Test Condition		Min.	Typ.	Max.	Unit
		V_{CC}	Conditions				
V_{CC}	Operating Voltage	—	$-40^{\circ}C$ to $85^{\circ}C$	2.2	—	5.5	V
I_{CC1}	Operating Current	5V	Read at 400kHz	—	—	2	mA
I_{CC2}	Operating Current	5V	Write at 400kHz	—	—	5	mA
V_{IL}	Input Low Voltage	—	—	-0.45	—	$0.3V_{CC}$	V
V_{IH}	Input High Voltage	—	—	$0.7V_{CC}$	—	$V_{CC}+0.5$	V
V_{OL}	Output Low Voltage	2.2V	$I_{OL}=2.1mA$	—	—	0.4	V
I_{LI}	Input Leakage Current	5V	$V_{IN}=0$ or V_{CC}	—	—	1	μA
I_{LO}	Output Leakage Current	5V	$V_{OUT}=0$ or V_{CC}	—	—	1	μA
I_{STB}	Standby Current	5V	$V_{IN}=0$ or V_{CC}	—	—	3	μA
			SDA, SCL= V_{CC} A0, A1, A2, WP= V_{SS}	—	—	1	μA
		2.2V	$V_{IN}=0$ or V_{CC}	—	—	2	μA
			SDA, SCL= V_{CC} A0, A1, A2, WP= V_{SS}	—	—	1	μA
C_{IN}	Input Capacitance (See note)	—	$f_{SK}=1MHz$ @ $25^{\circ}C$	—	—	6	pF
C_{OUT}	Output Capacitance (See note)	—	$f_{SK}=1MHz$ @ $25^{\circ}C$	—	—	8	pF

Note: These parameters are periodically sampled but not 100% tested.



A.C Characteristics

Ta=-40°C to 85°C

Symbol	Parameter	Remark	V _{CC} =2.2~5.5V		V _{CC} =2.5~5.5V		Unit
			Min.	Max.	Min.	Max.	
f _{SK}	Clock Frequency	—	—	400	—	1000	kHz
t _{HIGH}	Clock High Time	—	600	—	400	—	ns
t _{LOW}	Clock Low Time	—	1200	—	600	—	ns
t _r	SDA and SCL Rise Time	Note	—	300	—	300	ns
t _f	SDA and SCL Fall Time	Note	—	300	—	300	ns
t _{HD:STA}	START Condition Hold Time	After this period the first clock pulse is generated	600	—	250	—	ns
t _{SU:STA}	START Condition Setup Time	Only relevant for repeated START condition	600	—	250	—	ns
t _{HD:DAT}	Data Input Hold Time	—	0	—	0	—	ns
t _{SU:DAT}	Data Input Setup Time	—	150	—	100	—	ns
t _{SU:STO}	STOP Condition Setup Time	—	600	—	250	—	ns
t _{AA}	Output Valid from Clock	—	—	900	—	600	ns
t _{BUF}	Bus Free Time	Time in which the bus must be free before a new transmission can start	1200	—	500	—	ns
t _{SP}	Input Filter Time (SDA and SCL Pins)	Noise suppression time	—	50	—	50	ns
t _{WR}	Write Cycle Time	—	—	5	—	5	ms
Endurance	25°C, Page Mode	5.0V	1,000,000				Write Cycles

Note: These parameters are periodically sampled but not 100% tested. For relative timing, refer to timing diagrams.



Functional Description

Pin Function

- Serial clock – SCL
The positive edge of the SCL input is used to clock data into the EEPROM device. The negative edge is used to clock data out of the device.
- Serial data – SDA
The SDA pin is bidirectional for serial data transfer. The pin is open drain driven and may be wired-OR with any number of other open drain or open collector devices.
- Address Inputs – A0, A1, A2
The A2, A1 and A0 pins are device address inputs that are hard wired or left not connected. When the pins are hard wired, as many as eight 128K devices may be addressed on a single bus system (device addressing is discussed in detail under the Device Addressing section). The code for the selected device is setup by connecting these inputs to either VSS or VCC. If any pin is left unconnected in a floating state will be internally read as having a low input, VSS, value.
- Write protect – WP
The HT24LC128 has a write protect pin that provides hardware data protection. The write protect pin allows normal read/write operations when connected to VSS or left floating. When the write protect pin is connected to VCC, the write protection feature is enabled and operates as shown in the following table.

WP Pin Status	Protect Array
V _{CC}	Full Array – 128K
V _{SS} or floating	Normal Read/Write Operations

Memory Structure

The device is internally structured into 16K 8-bit words. A 14-bit data word address is required for word addressing.

Device Operation

- Clock and data transition
Data transfer may be initiated only when the bus is not busy. During data transfer, the data line must remain stable whenever the clock line is high. Changes in the data line while the clock line is high will be interpreted as a START or STOP condition.
- Start condition
A high-to-low transition of SDA with SCL high is a start condition which must precede any other command (refer to Start and Stop Definition Timing diagram).

- Stop condition
A low-to-high transition of SDA with SCL high is a stop condition. After a read sequence, the stop command will place the EEPROM in a standby power mode (refer to Start and Stop Definition Timing Diagram).
- Acknowledge
All addresses and data words are serially transmitted to and from the EEPROM in 8-bit words. The EEPROM sends a zero to acknowledge that it has received each word. This happens during the ninth clock cycle.

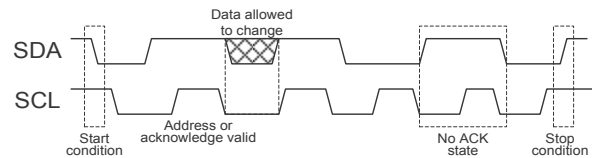

Start and Stop Definition Timing diagram

Device Addressing

The 128K EEPROM device requires an 8-bit device address word following a start condition to enable the chip for a read or write operation. The device address word consists of a mandatory one, zero sequence for the first four most significant bits (refer to the diagram showing the Device Address). This is common to all the EEPROM devices.

The 128K EEPROM uses the three device address bits A2, A1, A0 to allow as many as eight devices on the same bus. These bits are compared to their corresponding hard wired input pins.

The 8th bit device address is the read/write operation select bit. A read operation is initiated if this bit is high and a write operation is initiated if this bit is low. If the comparison of the device address is successful, the EEPROM will output a zero ACK bit. If not, the device will return to the standby state.

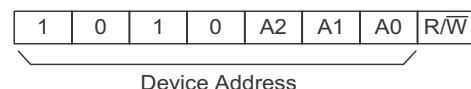



Write Operations

- Byte write

A write operation requires two data word addresses following the device address word and acknowledgment. Upon receipt of this address, the EEPROM will again respond with a zero and then clock in the first 8-bit data word. After receiving the 8-bit data word, the EEPROM will output a zero and the addressing device, such as a microcontroller, must terminate the write sequence with a stop condition. At this time the EEPROM will execute an internally-timed write cycle to the non-volatile memory. All inputs are disabled during this write cycle and the EEPROM will not respond until the write operation is completed (refer to Byte write timing).

- Page write

The 128K EEPROM is capable of a 64-byte page write. A page write is initiated in the same way as a byte write, but the microcontroller does not send a stop condition after the first data word is clocked in. Instead, after the EEPROM acknowledges the receipt of the first data word, the microcontroller can transmit up to 63 more data words. The EEPROM will respond with a zero after each data word received. The microcontroller must terminate the page write sequence with a stop condition (refer to Page write timing). The data word address lower 6 bits are internally incremented following the receipt of each data word. The higher data word address bits are not incremented, retaining the memory page row location. When the word address, internally generated, reaches the page boundary, the following byte is placed at the beginning of the same page. If more than 64 data words are transmitted to the EEPROM, the data word address will “roll over” and previous data will be overwritten.

- Acknowledge polling

To maximize bus throughput, one technique is to allow the master to poll for an acknowledge signal after the start condition and the control byte for a write command has been sent. If the device is still busy implementing its write cycle, then no ACK will be returned. The master can send the next read/write command when the ACK signal has finally been received.

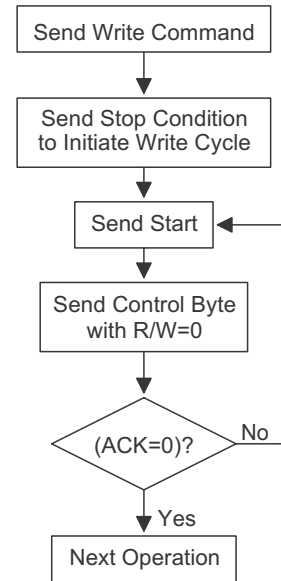

Acknowledge Polling Flow

- Write protect

The HT24LC128 device has a write-protect function. Programming will be inhibited when the WP pin is connected to VCC. In this mode, the HT24LC128 device can be used as a serial ROM.

Read Operations

The HT24LC128 device supports three read operations, namely, current address read, random address read and sequential read. During read operation execution, the read/write select bit should be set to “1”.

- Current address read

The internal data word address counter maintains the last address accessed during the last read or write operation, incremented by one. This address remains valid between operations as long as the chip power is maintained. The address will roll over during a read from the last byte of the last memory page to the first byte of the first page. The address will roll over during a write from the last byte of the current page to the first byte of the same page. Once the device address with the read/write select bit set to one is clocked in and acknowledged by the EEPROM, the current address data word is serially clocked out. The microcontroller does not respond with an input zero but generates a following stop condition (refer to Current read timing).



- Random read

A random read requires a dummy byte write sequence to load in the data word address which is then clocked in and acknowledged by the EEPROM. The microcontroller must then generate another start condition. The microcontroller now initiates a current address read by sending a device address with the read/write select bit high. The EEPROM acknowledges the device address and serially clocks out the data word. The microcontroller should respond with a “no ACK” signal (high) followed by a stop condition (refer to Random read timing).

- Sequential read

Sequential reads are initiated by either a current address read or a random address read. After the microcontroller receives a data word, it responds with an acknowledgment. As long as the EEPROM receives an acknowledgment, it will continue to increment the data word address and serially clock out sequential data words. When the memory address limit is reached, the data word address will roll over and the sequential read continues. The sequential read operation is terminated when the microcontroller does not respond with a zero but generates a following stop condition.

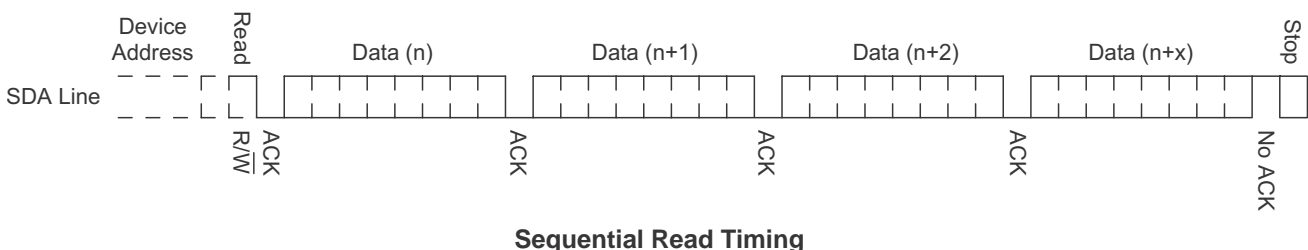
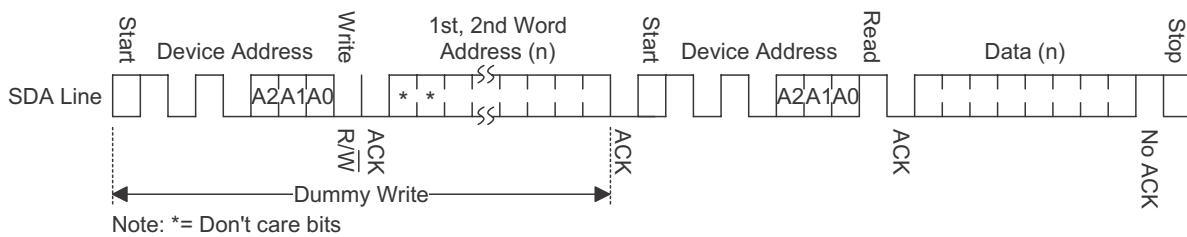
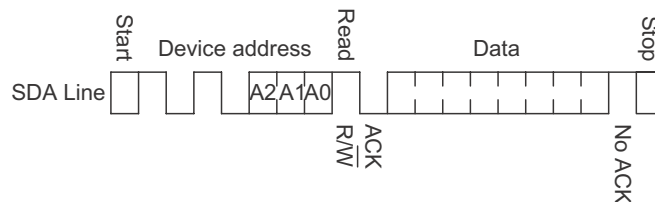
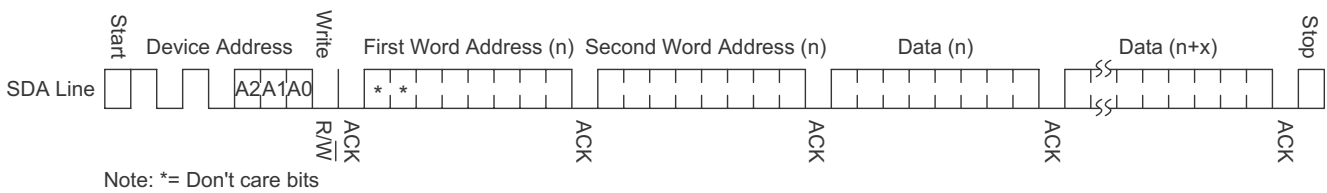
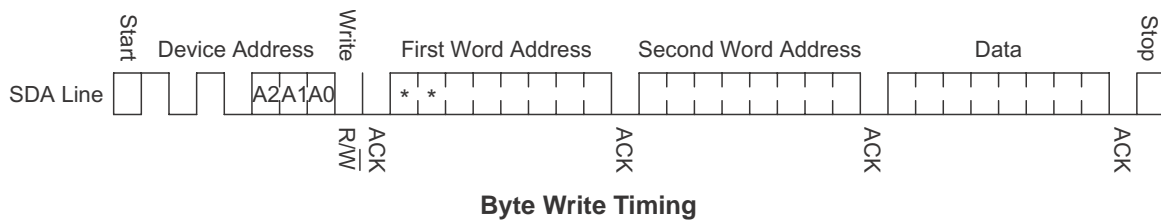



Timing Diagrams

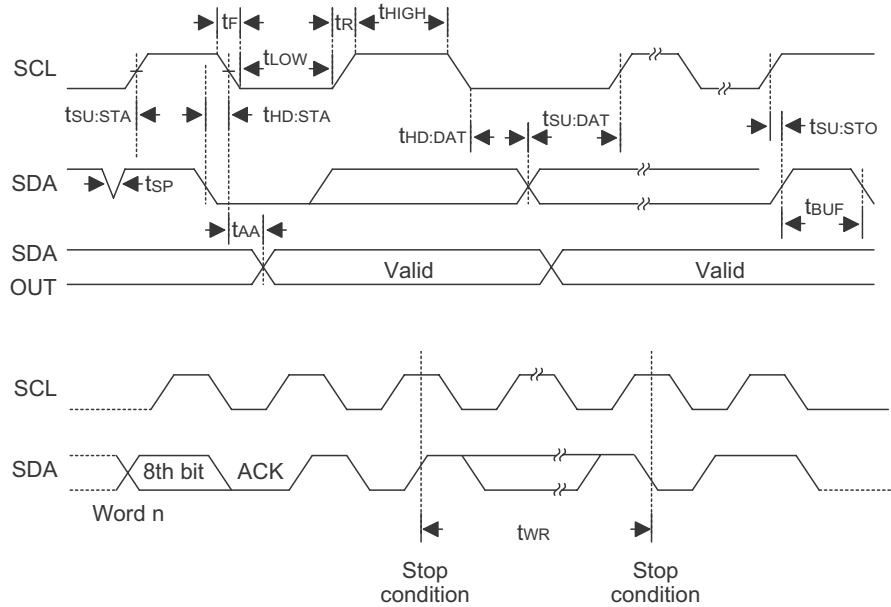

Note: The write cycle time t_{WR} is the time from a valid stop condition of a write sequence to the end of the valid start condition of sequential command.



8-pin DIP (300mil) Outline Dimensions

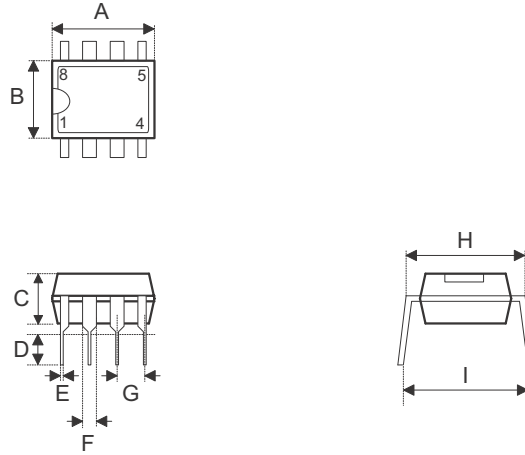

Symbol	Dimensions in inch		
	Min.	Nom.	Max.
A	0.355	0.365	0.400
B	0.240	0.250	0.280
C	0.115	0.130	0.195
D	0.115	0.130	0.150
E	0.014	0.018	0.022
F	0.045	0.060	0.070
G	—	0.100 BSC	—
H	0.300	0.310	0.325
I	—	—	0.430

Symbol	Dimensions in mm		
	Min.	Nom.	Max.
A	9.02	9.27	10.16
B	6.10	6.35	7.11
C	2.92	3.30	4.95
D	2.92	3.30	3.81
E	0.36	0.46	0.56
F	1.14	1.52	1.78
G	—	2.54 BSC	—
H	7.26	7.87	8.26
I	—	—	10.92



8-pin SOP(SOIC-8) (150mil) Outline Dimensions

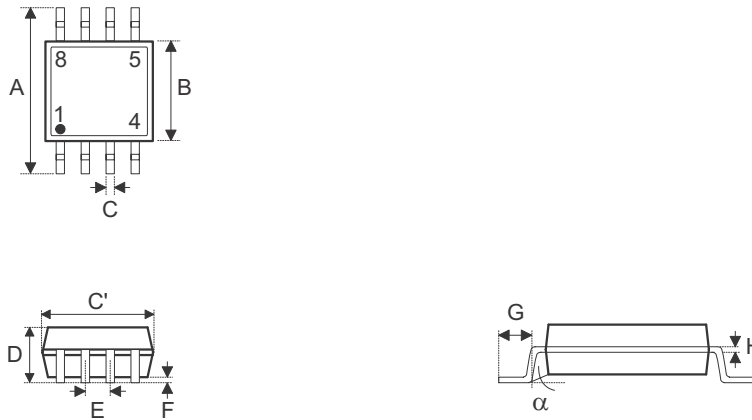

Symbol	Dimensions in inch		
	Min.	Nom.	Max.
A	—	0.236 BSC	—
B	—	0.154 BSC	—
C	0.012	—	0.020
C'	—	0.193 BSC	—
D	—	—	0.069
E	—	0.050 BSC	—
F	0.004	—	0.010
G	0.016	—	0.050
H	0.004	—	0.010
α	0°	—	8°

Symbol	Dimensions in mm		
	Min.	Nom.	Max.
A	—F	6.00 BSC	—
B	—	3.90 BSC	—
C	0.31	—	0.51
C'	—	4.90 BSC	—
D	—	—	1.75
E	—	1.27 BSC	—
F	0.10	—	0.25
G	0.40	—	1.27
H	0.10	—	0.25
α	0°	—	8°



8-pin TSSOP Outline Dimensions

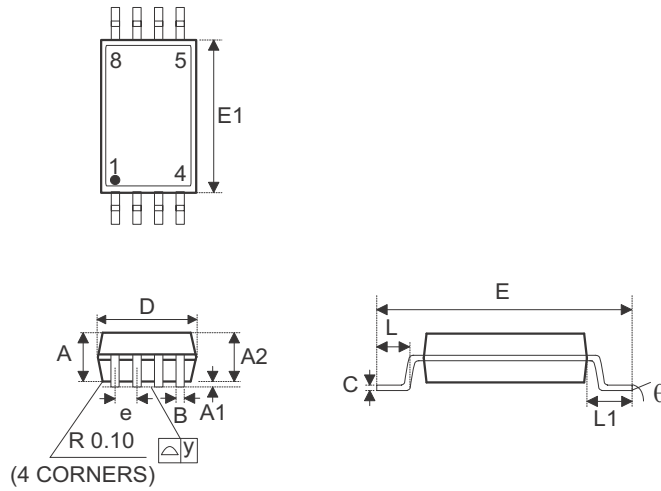

Symbol	Dimensions in inch		
	Min.	Nom.	Max.
A	—	—	0.047
A1	0.002	—	0.006
A2	0.031	0.039	0.041
B	0.007	—	0.012
C	0.004	—	0.006
D	0.114	0.118	0.122
E	—	0.252 BSC	—
E1	0.169	0.173	0.177
e	—	0.026 BSC	—
L	0.018	0.024	0.030
L1	—	0.039 BSC	—
y	—	0.004	—
θ	0°	—	8°

Symbol	Dimensions in mm		
	Min.	Nom.	Max.
A	—	—	1.20
A1	0.05	—	0.15
A2	0.80	1	1.05
B	0.19	—	0.30
C	0.09	—	0.16
D	2.90	3.00	3.10
E	—	6.40 BSC	—
E1	4.30	4.40	4.50
e	—	0.65 BSC	—
L	0.45	0.60	0.75
L1	—	1.0 BSC	—
y	—	0.10	—
θ	0°	—	8°



Attention

- Any and all HUA XUAN YANG ELECTRONICS products described or contained herein do not have specifications that can handle applications that require extremely high levels of reliability, such as life-support systems, aircraft's control systems, or other applications whose failure can be reasonably expected to result in serious physical and/or material damage. Consult with your HUA XUAN YANG ELECTRONICS representative nearest you before using any HUA XUAN YANG ELECTRONICS products described or contained herein in such applications.
- HUA XUAN YANG ELECTRONICS assumes no responsibility for equipment failures that result from using products at values that exceed, even momentarily, rated values (such as maximum ratings, operating condition ranges, or other parameters) listed in products specifications of any and all HUA XUAN YANG ELECTRONICS products described or contained herein.
- Specifications of any and all HUA XUAN YANG ELECTRONICS products described or contained herein stipulate the performance, characteristics, and functions of the described products in the independent state, and are not guarantees of the performance, characteristics, and functions of the described products as mounted in the customer's products or equipment. To verify symptoms and states that cannot be evaluated in an independent device, the customer should always evaluate and test devices mounted in the customer's products or equipment.
- HUA XUAN YANG ELECTRONICS CO.,LTD. strives to supply high-quality high-reliability products. However, any and all semiconductor products fail with some probability. It is possible that these probabilistic failures could give rise to accidents or events that could endanger human lives, that could give rise to smoke or fire, or that could cause damage to other property. When designing equipment, adopt safety measures so that these kinds of accidents or events cannot occur. Such measures include but are not limited to protective circuits and error prevention circuits for safe design, redundant design, and structural design.
- In the event that any or all HUA XUAN YANG ELECTRONICS products(including technical data, services) described or contained herein are controlled under any of applicable local export control laws and regulations, such products must not be exported without obtaining the export license from the authorities concerned in accordance with the above law.
- No part of this publication may be reproduced or transmitted in any form or by any means, electronic or mechanical, including photocopying and recording, or any information storage or retrieval system, or otherwise, without the prior written permission of HUA XUAN YANG ELECTRONICS CO.,LTD.
- Information (including circuit diagrams and circuit parameters) herein is for example only ; it is not guaranteed for volume production. HUA XUAN YANG ELECTRONICS believes information herein is accurate and reliable, but no guarantees are made or implied regarding its use or any infringements of intellectual property rights or other rights of third parties.
- Any and all information described or contained herein are subject to change without notice due to product/technology improvement, etc. When designing equipment, refer to the "Delivery Specification" for the HUA XUAN YANG ELECTRONICS product that you intend to use.