

## 3A Ultra-small Load Switch with Slew Rate Control

### Features

- Integrated P-channel MOSFET load switch
- Input voltage: 1.2V to 5.5V
- 3A maximum continuous switch current
- Switch on-resistance(typ.):  
Rdson=17mΩ at VIN=5.5V  
Rdson=22mΩ at VIN=3.3V  
Rdson=81mΩ at VIN=1.2V
- Controlled slew rate to limit inrush currents
- Ultra low shutdown current
- Internal EN pull-down resistor
- Quick output discharge(QOD)
- WLCSP 1.355mm×0.855mm×0.55mm-6B

### General Description

The AW35131ACSR is a load switch with output slew rate control. The device integrates a 22mΩ (typ.) P-channel MOSFET, which can operate over a wide input range of 1.2V to 5.5V.

The AW35131ACSR features output slew rate control, limiting inrush currents during turn-on to protect downstream devices. In addition, AW35131ACSR has QOD function which can prevent the output from floating when the switch is disabled.

### Applications

Smart Wear

Vehicle Module

High-Definition Television(HDTV)

### Typical Application Circuit

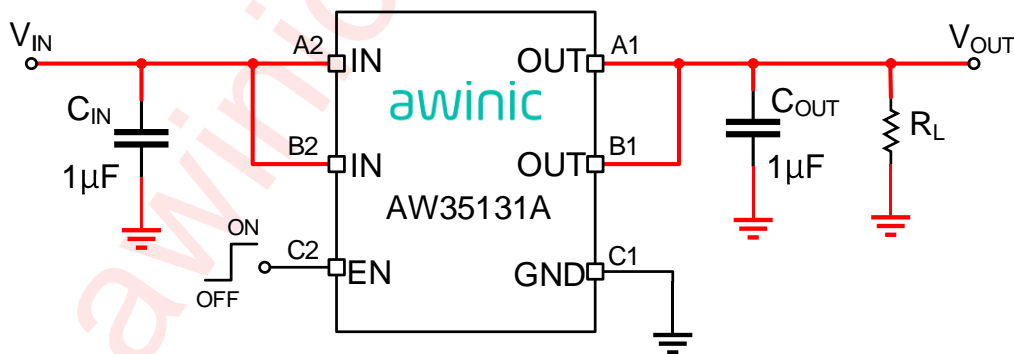

Figure 1 Typical Application circuit of AW35131ACSR

## Pin Configuration And Top Mark

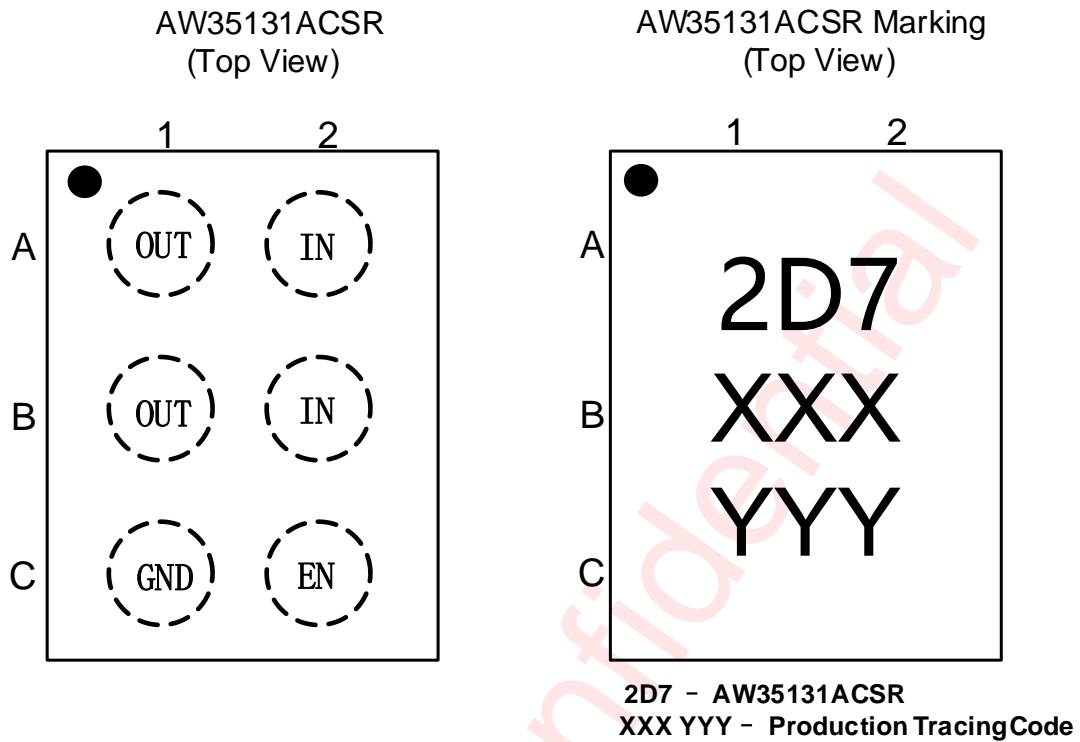

Figure 2 Pin Configuration and Top Mark

## Pin Definition

| Pin | Name | Description                       |
|-----|------|-----------------------------------|
| A1  | OUT  | Switch output                     |
| B1  |      |                                   |
| C1  | GND  | Device ground                     |
| A2  | IN   | Switch input and power supply     |
| B2  |      |                                   |
| C2  | EN   | Switch control input, active high |

## Functional Block Diagram

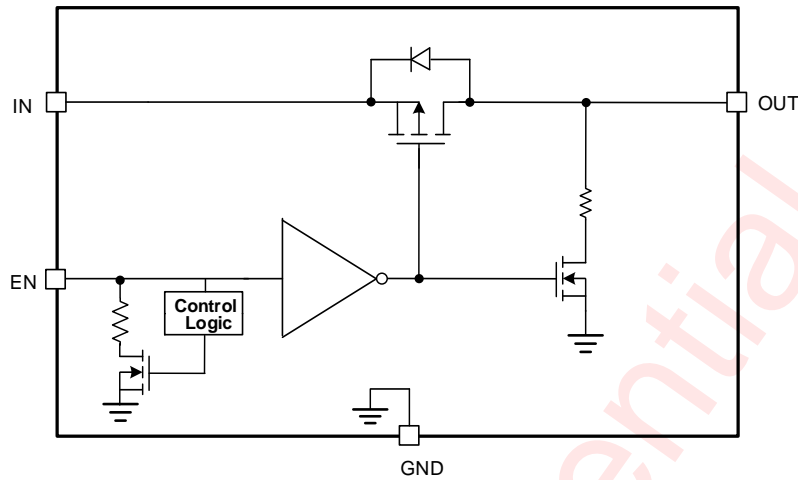

Figure 3 Functional Block Diagram

## Typical Application Circuits

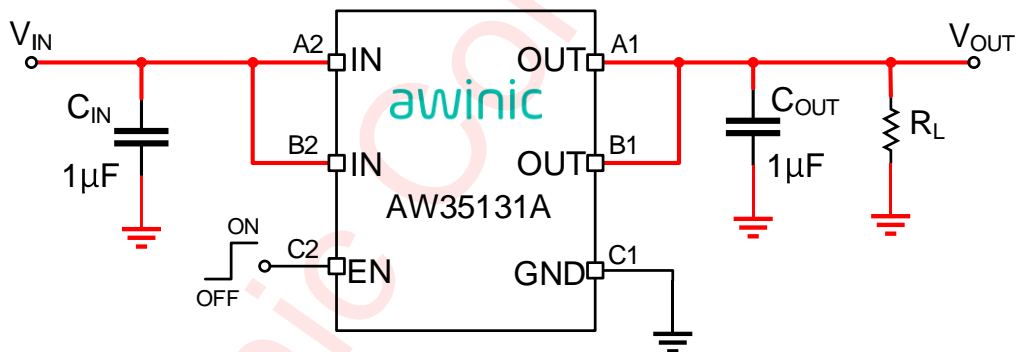

Figure 4 Typical Application circuit of AW35131ACSR

## Ordering Information

| Part Number | Temperature | Package                                    | Marking | Moisture Sensitivity Level | Environmental Information | Delivery Form                   |
|-------------|-------------|--------------------------------------------|---------|----------------------------|---------------------------|---------------------------------|
| AW35131ACSR | -40°C~85°C  | WLCSP<br>1.355mm×0.85<br>5mm×0.55mm<br>-6B | 2D7     | MSL1                       | ROHS+HF                   | 4500 units/<br>Tape and<br>Reel |

**Absolute Maximum Ratings**<sup>(NOTE1)</sup>

| PARAMETERS                                                                         |     | RANGE                     |
|------------------------------------------------------------------------------------|-----|---------------------------|
| Supply Voltage Range $V_{IN}$                                                      |     | -0.3V to 6V               |
| Enable Voltage Range                                                               | EN  | -0.3V to 6V               |
| Output Voltage Range                                                               | OUT | -0.3V to 6V               |
| Maximum Continuous Switch Current for $V_{IN} \geq 1.5V$                           |     | 3A                        |
| Maximum Continuous Switch Current for $1.2 \leq V_{IN} < 1.5V$ <sup>(NOTE 2)</sup> |     | 2A                        |
| Maximum Peak Switch Current for $V_{IN} \geq 2.5V$ <sup>(NOTE 3)</sup>             |     | 4A                        |
| Junction-to-ambient Thermal Resistance $\theta_{JA}$ <sup>(NOTE 4)</sup>           |     | 100°C/W                   |
| Operating Free-air Temperature Range                                               |     | -40°C to 85°C             |
| Maximum Junction Temperature $T_{JMAX}$                                            |     | 150°C                     |
| Storage Temperature $T_{STG}$                                                      |     | -65°C to 150°C            |
| Lead Temperature (Soldering 10 Seconds)                                            |     | 260°C                     |
| ESD                                                                                |     |                           |
| HBM (Human Body Model) <sup>(NOTE 5)</sup>                                         |     | ±2kV                      |
| CDM (Charged Device Model) <sup>(NOTE 6)</sup>                                     |     | ±1.5kV                    |
| Latch-Up                                                                           |     |                           |
| Latch-Up <sup>(NOTE 7)</sup>                                                       |     | +IT: 200mA<br>-IT: -200mA |

**NOTE1:** Conditions out of those ranges listed in "absolute maximum ratings" may cause permanent damages to the device. In spite of the limits above, functional operation conditions of the device should within the ranges listed in "recommended operating conditions". Exposure to absolute-maximum-rated conditions for prolonged periods may affect device reliability.

**NOTE2:** The power mos enters saturation region, load capacity is reduced.

**NOTE3:** Limited by thermal design, and tested in 10ms width pulse current.

**NOTE4:** Thermal resistance from junction to ambient is highly dependent on PCB layout.

**NOTE5:** The human body model is a 100pF capacitor discharged through a 1.5kΩ resistor into each pin. Test method: ESDA/JEDEC JS-001-2017.

**NOTE6:** All pins. Test Condition: ESDA/JEDEC JS-002-2018.

**NOTE7:** Test Condition: JESD78E.

**Recommended Operating Conditions**

| Symbol    | Parameter               | Min. | Typ. | Max.     | Unit |
|-----------|-------------------------|------|------|----------|------|
| $V_{IN}$  | Input Voltage           | 1.2  |      | 5.5      | V    |
| $V_{EN}$  | EN Voltage              | 0    |      | 5.5      | V    |
| $V_{OUT}$ | Output Voltage          | 0    |      | $V_{IN}$ | V    |
| $C_{IN}$  | Input capacitance       | 0.1  | 1    |          | μF   |
| $C_{OUT}$ | Output load capacitance | 0.1  | 1    |          | μF   |

## Electrical Characteristics

$T_A = 25^\circ\text{C}$  unless otherwise noted. Typical values are guaranteed for  $V_{IN} = 3.3\text{V}$ ,  $C_{IN} = 1\mu\text{F}$ ,  $I_{IN} \leq 3\text{A}$ .

| PARAMETER             |                                            | TEST CONDITION                                                                                 | MIN | TYP | MAX  | UNIT |
|-----------------------|--------------------------------------------|------------------------------------------------------------------------------------------------|-----|-----|------|------|
| <b>INPUT CURRENTS</b> |                                            |                                                                                                |     |     |      |      |
| $I_Q$                 | Input quiescent current                    | $V_{IN}=3.3\text{V}$ , $V_{EN}=3.3\text{V}$ , $I_{OUT}=0\text{A}$ , $T_A=25^\circ\text{C}$     |     | 3   |      | nA   |
|                       |                                            | $V_{IN}=3.3\text{V}$ , $V_{EN}=3.3\text{V}$ , $I_{OUT}=0\text{A}$ , $T_A=85^\circ\text{C}$     |     | 11  |      | nA   |
|                       |                                            | $V_{IN}=5.5\text{V}$ , $V_{EN}=5.5\text{V}$ , $I_{OUT}=0\text{A}$ , $T_A=25^\circ\text{C}$     |     | 5   | 600  | nA   |
|                       |                                            | $V_{IN}=5.5\text{V}$ , $V_{EN}=5.5\text{V}$ , $I_{OUT}=0\text{A}$ , $T_A=85^\circ\text{C}$     |     | 17  |      | nA   |
| $I_{SD}$              | Shutdown current from IN to GND            | $V_{IN}=1.2\text{V}$ , $V_{EN}=0\text{V}$ , $T_A=25^\circ\text{C}$                             |     | 3   |      | nA   |
|                       |                                            | $V_{IN}=1.8\text{V}$ , $V_{EN}=0\text{V}$ , $T_A=25^\circ\text{C}$                             |     | 4   |      | nA   |
|                       |                                            | $V_{IN}=3.3\text{V}$ , $V_{EN}=0\text{V}$ , $T_A=25^\circ\text{C}$                             |     | 6   |      | nA   |
|                       |                                            | $V_{IN}=3.3\text{V}$ , $V_{EN}=0\text{V}$ , $T_A=85^\circ\text{C}$                             |     | 11  |      | nA   |
|                       |                                            | $V_{IN}=4.5\text{V}$ , $V_{EN}=0\text{V}$ , $T_A=25^\circ\text{C}$                             |     | 8   |      | nA   |
|                       |                                            | $V_{IN}=5.5\text{V}$ , $V_{EN}=0\text{V}$ , $T_A=25^\circ\text{C}$                             |     | 15  | 600  | nA   |
|                       |                                            | $V_{IN}=5.5\text{V}$ , $V_{EN}=0\text{V}$ , $T_A=85^\circ\text{C}$                             |     | 18  |      | nA   |
| $I_{LEAKEN}$          | EN pin leakage current                     | $V_{IN}=0\text{V}$ , $V_{EN}=5.5\text{V}$                                                      |     | 546 | 1000 | nA   |
| $R_{EN}$              | EN pin pull down resistor                  | $V_{IN}=5.0\text{V}$ , $V_{EN}=0.1\text{V}$                                                    |     | 9.2 |      | MΩ   |
| <b>POWER SWITCH</b>   |                                            |                                                                                                |     |     |      |      |
| $R_{dson}$            | Internal switch MOSFET on-state resistance | $V_{IN}=5.5\text{V}$ , $V_{EN}=\text{high}$ , $I_{OUT}=200\text{mA}$ , $T_A=25^\circ\text{C}$  |     | 17  |      | mΩ   |
|                       |                                            | $V_{IN}=3.3\text{V}$ , $V_{EN}=\text{high}$ , $I_{OUT}=200\text{mA}$ , $T_A=25^\circ\text{C}$  |     | 22  |      |      |
|                       |                                            | $V_{IN}=1.8\text{V}$ , $V_{EN}=\text{high}$ , $I_{OUT}=200\text{mA}$ , $T_A=25^\circ\text{C}$  |     | 37  |      |      |
|                       |                                            | $V_{IN}=1.2\text{V}$ , $V_{EN}=\text{high}$ , $I_{OUT}=200\text{mA}$ , $T_A=25^\circ\text{C}$  |     | 81  |      |      |
| $R_{DIS}$             | Output discharge resistance                | $V_{IN}=3.3\text{V}$ , $V_{EN}=\text{low}$ , $T_A=25^\circ\text{C}$ ,<br>$I_{OUT}$ Sinking 2mA |     | 87  |      | Ω    |
| $t_R$                 | Output rise time                           | $V_{IN}=3.3\text{V}$ , $C_{OUT}=1\mu\text{F}$ , $R_L=5\Omega$                                  |     | 320 |      | μs   |
| $t_F$                 | Output fall time                           | $V_{IN}=3.3\text{V}$ , $C_{OUT}=1\mu\text{F}$ , $R_L=5\Omega$                                  |     | 10  |      | μs   |
| $t_{ON}$              | Switch turn on time                        | $V_{IN}=3.3\text{V}$ , $C_{OUT}=1\mu\text{F}$ , $R_L=5\Omega$                                  |     | 405 |      | μs   |
| $t_{OFF}$             | Switch turn off time                       | $V_{IN}=3.3\text{V}$ , $C_{OUT}=1\mu\text{F}$ , $R_L=5\Omega$                                  |     | 4.1 |      | μs   |
| $t_{EN}$              | Enable time                                | $V_{IN}=3.3\text{V}$ , $C_{OUT}=1\mu\text{F}$ , $R_L=5\Omega$                                  |     | 253 |      | μs   |
| $V_{IH}$              | EN input high threshold level              |                                                                                                | 1.2 |     |      | V    |
| $V_{IL}$              | EN input low threshold level               |                                                                                                |     |     | 0.4  | V    |

## Timing Diagram

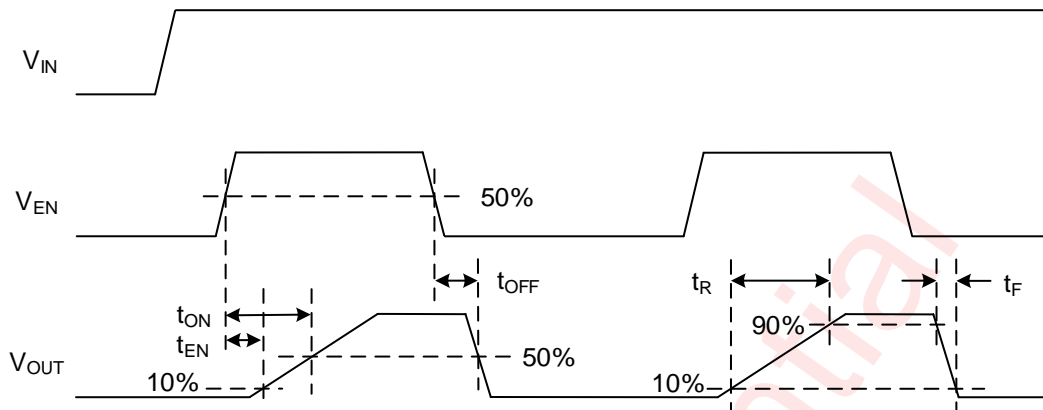
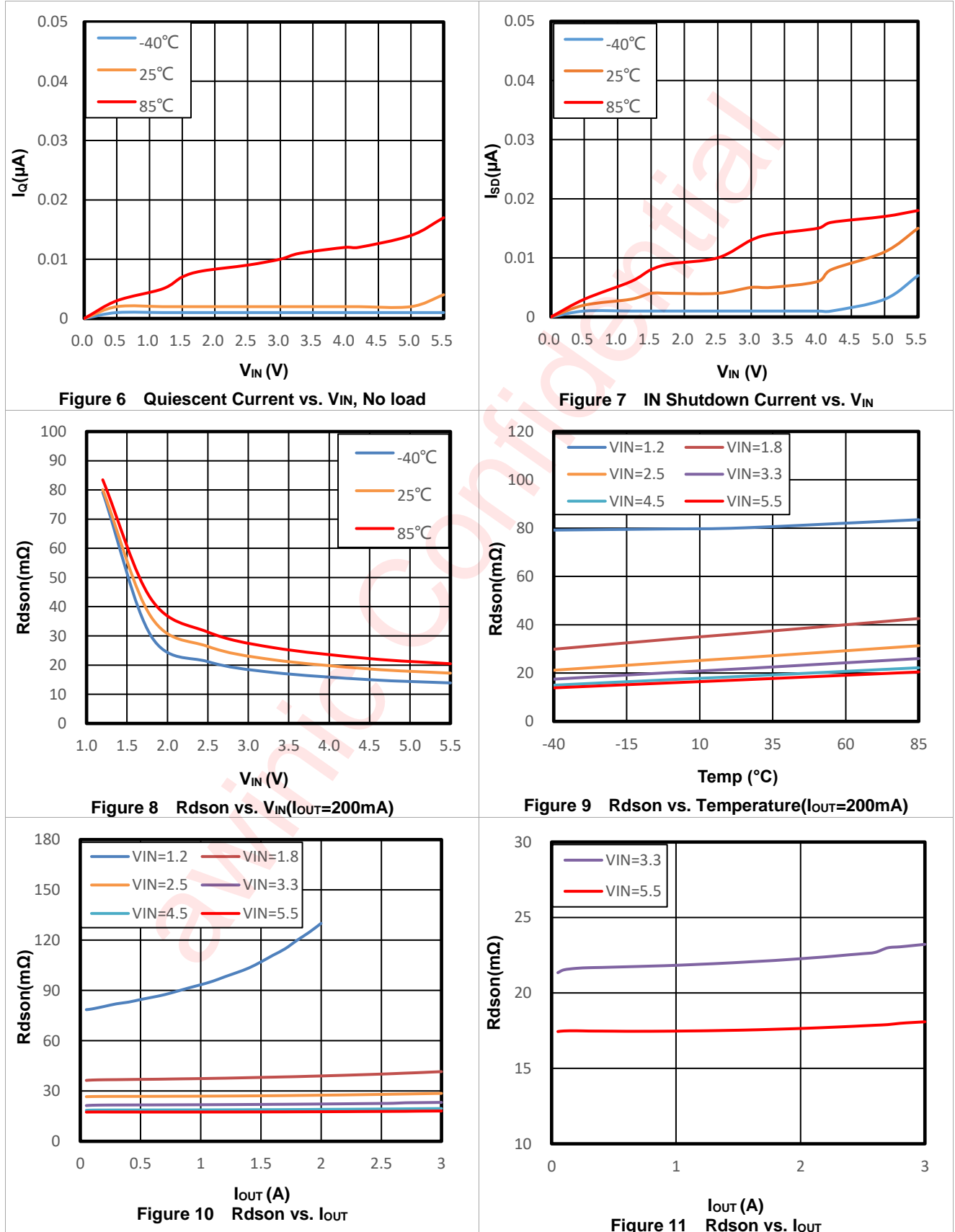
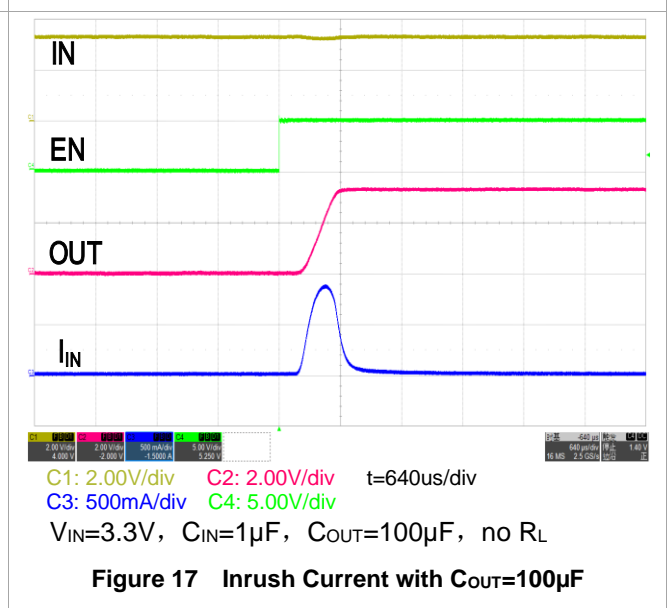
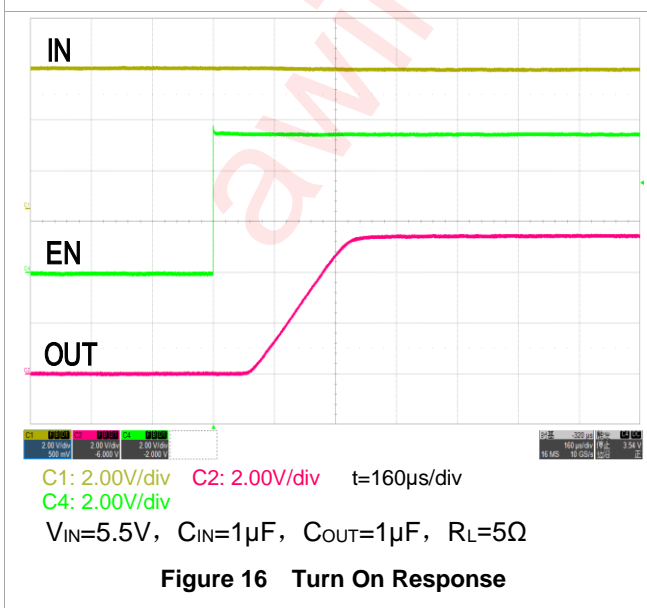
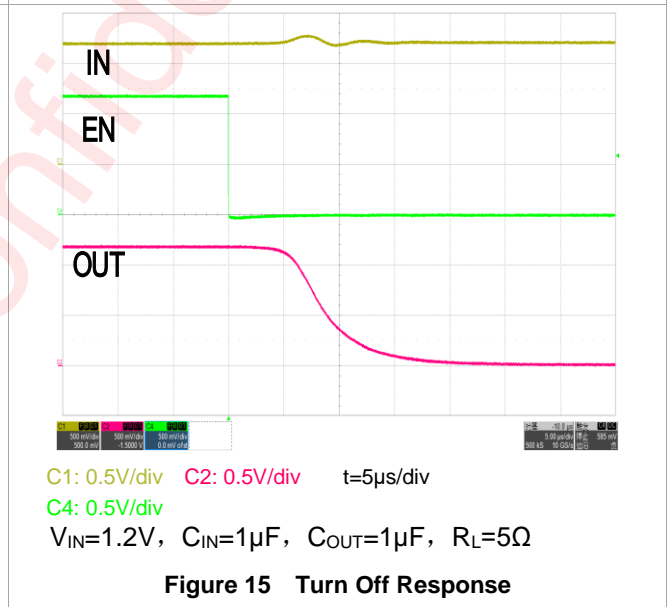
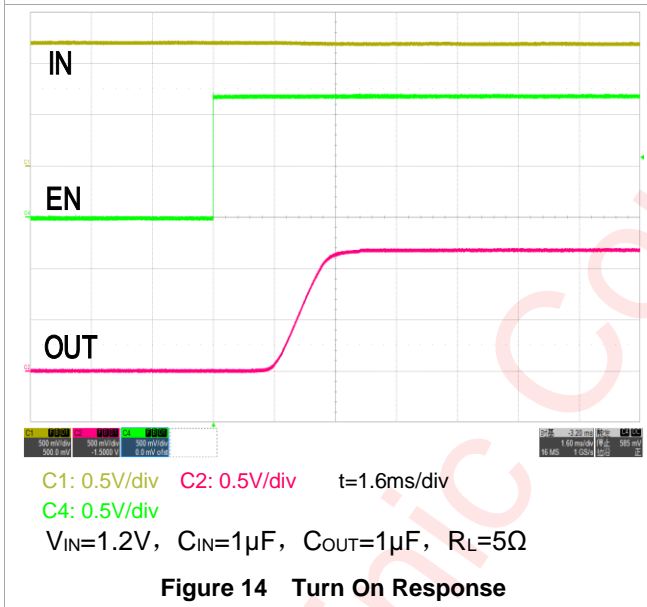
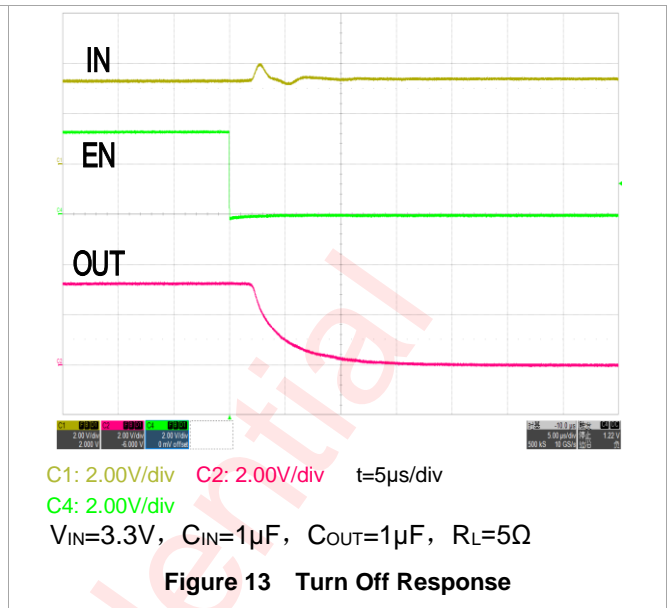
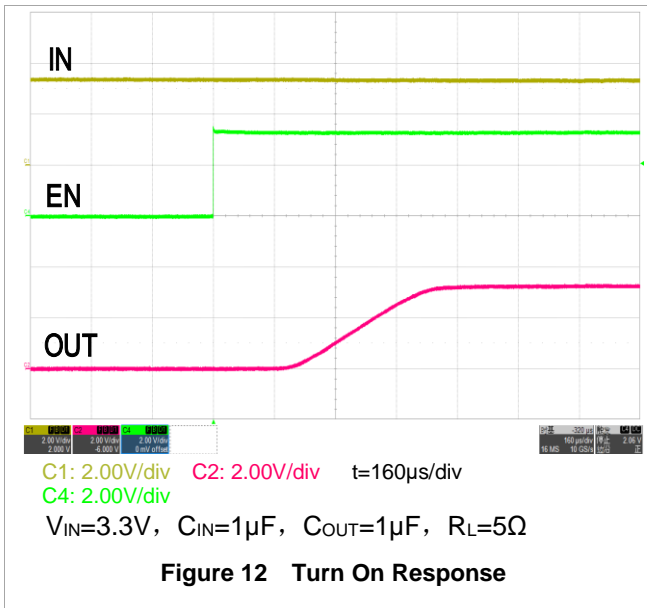

Figure 5 AW35131ACSR Timing Diagram

## Typical Characteristics

Ambient temperature is 25°C,  $C_{IN} = C_{OUT} = 1\mu F$ , unless otherwise noted.





## Detailed Functional Description

The AW35131ACSR integrates a high side P channel MOSFET load switch, and provides a low on-resistance for a low voltage drop across the device. A controlled slew rate is used in applications to limit the inrush current. The part can be turned on, with a supply voltage from 1.2V to 5.5V.

### Turn On/Off Control

Enable pin is an active high. The device is opened when EN pin is tied low (disable) or pulled down by internal 9.2M $\Omega$  resistor, forcing PMOS switch off. The IN/OUT path is activated with a minimum of  $V_{IN}$  of 1.2V and EN forced to high level.

Table 1. Functional Table

| EN   | IN to OUT | OUT to GND |
|------|-----------|------------|
| Low  | OFF       | OFF        |
| High | ON        | OFF        |

### Slew Rate Control

When the switch is enabled, the device regulates the gate voltage of MOSFET, and controls the  $V_{OUT}$  slew rate during  $t_R$  to avoid a large input inrush current. The feature reduces the interference to the power supply.

### Quick Output Discharge

The AW35131ACSR includes the Quick Output Discharge (QOD) feature, in order to discharge the application capacitor connected on OUT pin. When EN pin is set to low level (disable state), a discharge resistance with a typical value of 87 $\Omega$  is connected between the output and ground, pull down the output and prevent it from floating when the device is disabled.

## PCB Layout Consideration

AW35131ACSR is a low ON-Resistance load switch, to obtain the optimal performance, PCB layout should be considered carefully. Here are some guidelines:

1. All the peripherals should be placed as close to the device as possible. Place the input capacitor  $C_{IN}$  on the top layer (same layer as the AW35131ACSR) and close to IN pin, and place the output capacitor  $C_{OUT}$  on the top layer (same layer as the AW35131ACSR) and close to OUT pin.
2. The AW35131ACSR integrate an up to 3A rated PMOS FET, and the PCB design rules must be respected to properly evacuate the heat out of the silicon. By increasing PCB area, especially around IN and OUT pins, the  $R\theta_{JA}$  of the package can be decreased, allowing higher power dissipation. Blue bold paths on Figure 18 are power lines that will flow large current, please route them on PCB as straight, wide and short as possible.
3. Use rounded corners on the power trace from the power supply connector to AW35131ACSR to decrease EMI coupling.

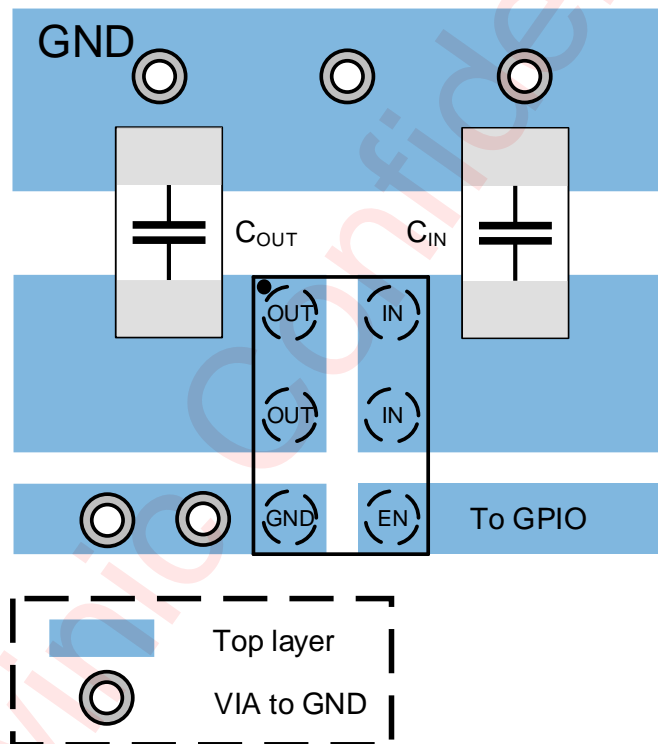
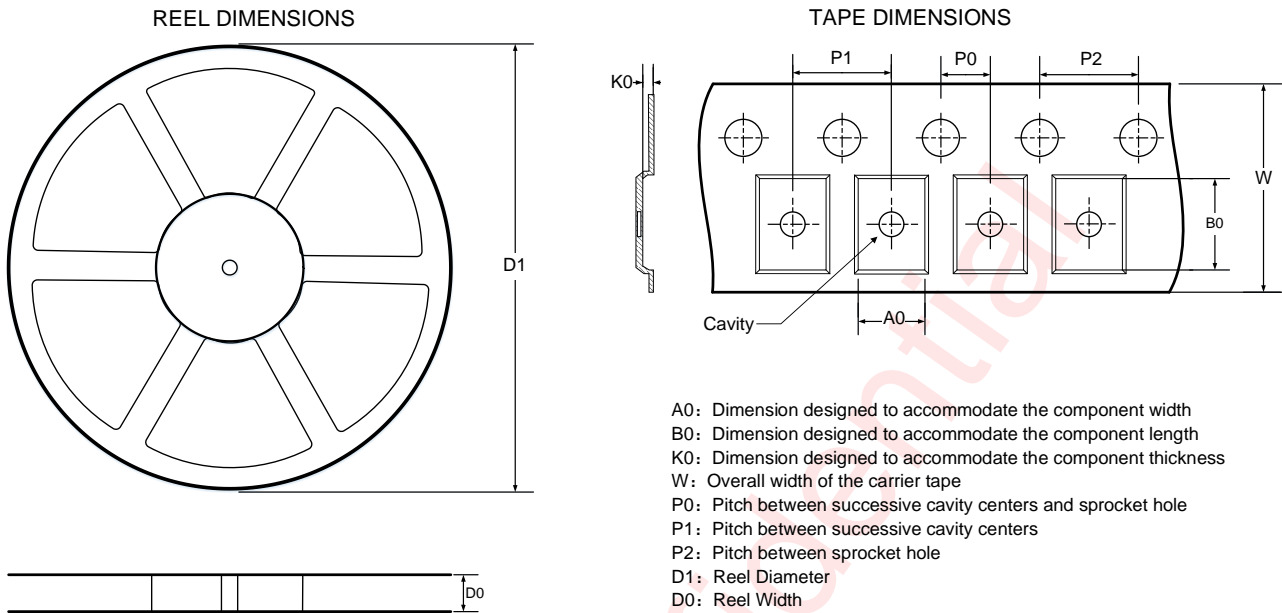
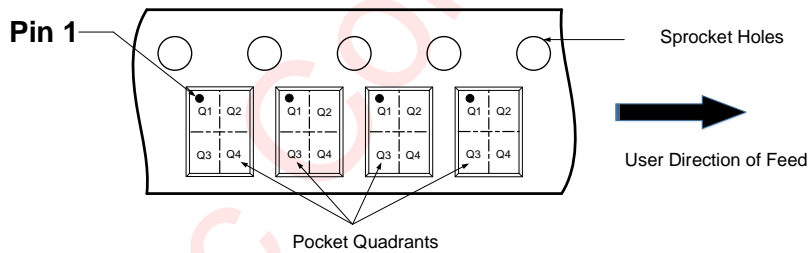

Figure 18 PCB layout example

## Tape And Reel Information



### QUADRANT ASSIGNMENTS FOR PIN 1 ORIENTATION IN TAPE



Note: The above picture is for reference only. Please refer to the value in the table below for the actual size

### DIMENSIONS AND PIN1 ORIENTATION

| D1 (mm) | D0 (mm) | A0 (mm) | B0 (mm) | K0 (mm) | P0 (mm) | P1 (mm) | P2 (mm) | W (mm) | Pin1 Quadrant |
|---------|---------|---------|---------|---------|---------|---------|---------|--------|---------------|
| 179.00  | 9.00    | 0.95    | 1.45    | 0.65    | 2.00    | 4.00    | 4.00    | 8.00   | Q1            |

All dimensions are nominal

Package Description

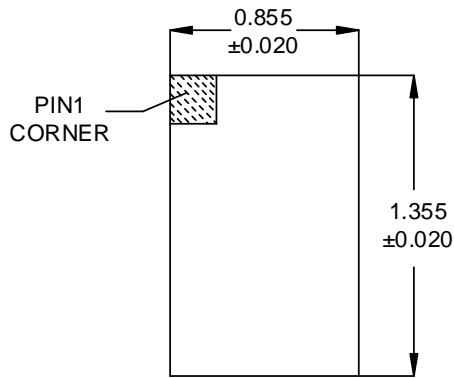

Top View

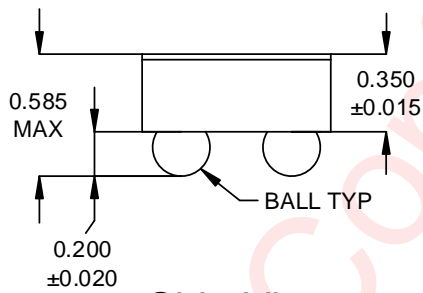

Side View

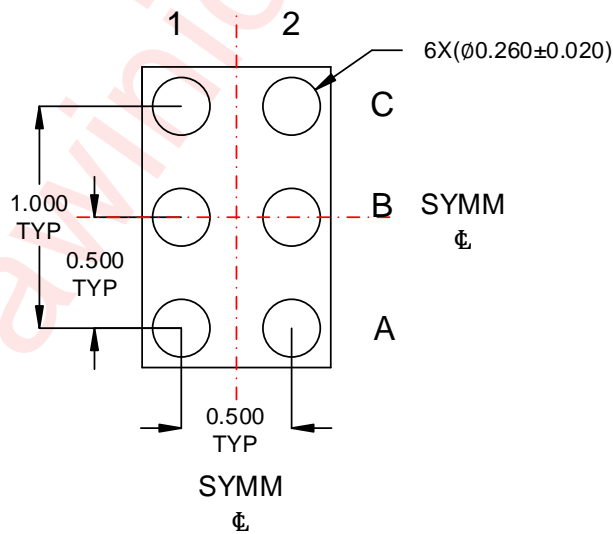

Bottom View

Unit: mm

Land Pattern Data

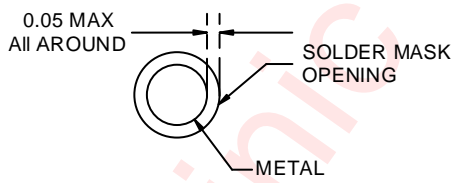
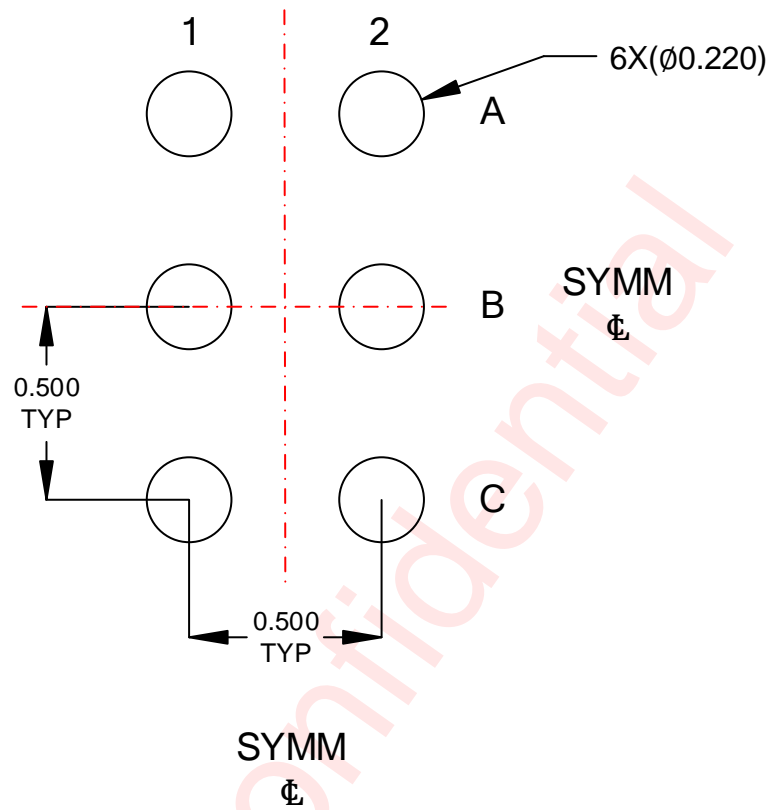

NON-SOLDER MASK DEFINED

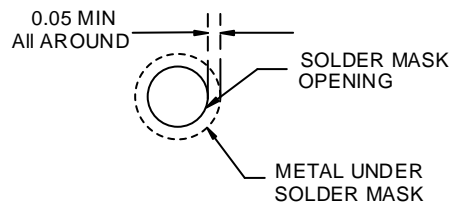

SOLDER MASK DEFINED

Unit: mm

## Revision History

| Version | Date      | Change Record                                                                                                                                                                                                                                                  |
|---------|-----------|----------------------------------------------------------------------------------------------------------------------------------------------------------------------------------------------------------------------------------------------------------------|
| V0.9    | Feb. 2022 | Officially released                                                                                                                                                                                                                                            |
| V1.0    | Jun. 2022 | <ol style="list-style-type: none"><li>1. Modify the parameter of Maximum Continuous Switch Current and Electrical Characteristics(P4、 P5)</li><li>2. Add the Typical Characteristics(P7、 P8)</li><li>3. Modify the figure of PCB layout example(P10)</li></ol> |
| V1.1    | Mar. 2023 | Modify the maximum value of $I_Q$ and $I_{SD}$ from 1000nA to 600nA(P5)                                                                                                                                                                                        |
| V1.2    | Oct. 2023 | Modify the test condition of $R_{EN}$ (P5)                                                                                                                                                                                                                     |

awinic Confidential

awinic Confidential

## Disclaimer

All trademarks are the property of their respective owners. Information in this document is believed to be accurate and reliable. However, Shanghai AWINIC Technology Co., Ltd (AWINIC Technology) does not give any representations or warranties, expressed or implied, as to the accuracy or completeness of such information and shall have no liability for the consequences of use of such information.

AWINIC Technology reserves the right to make changes to information published in this document, including without limitation specifications and product descriptions, at any time and without notice. Customers shall obtain the latest relevant information before placing orders and shall verify that such information is current and complete. This document supersedes and replaces all information supplied prior to the publication hereof.

AWINIC Technology products are not designed, authorized or warranted to be suitable for use in medical, military, aircraft, space or life support equipment, nor in applications where failure or malfunction of an AWINIC Technology product can reasonably be expected to result in personal injury, death or severe property or environmental damage. AWINIC Technology accepts no liability for inclusion and/or use of AWINIC Technology products in such equipment or applications and therefore such inclusion and/or use is at the customer's own risk.

Applications that are described herein for any of these products are for illustrative purposes only. AWINIC Technology makes no representation or warranty that such applications will be suitable for the specified use without further testing or modification.

All products are sold subject to the general terms and conditions of commercial sale supplied at the time of order acknowledgement.

Nothing in this document may be interpreted or construed as an offer to sell products that is open for acceptance or the grant, conveyance or implication of any license under any copyrights, patents or other industrial or intellectual property rights.

Reproduction of AWINIC information in AWINIC data books or data sheets is permissible only if reproduction is without alteration and is accompanied by all associated warranties, conditions, limitations, and notices. AWINIC is not responsible or liable for such altered documentation. Information of third parties may be subject to additional restrictions.

Resale of AWINIC components or services with statements different from or beyond the parameters stated by AWINIC for that component or service voids all express and any implied warranties for the associated AWINIC component or service and is an unfair and deceptive business practice. AWINIC is not responsible or liable for any such statements.