

3A Ultra-small Load Switch with Slew Rate Control

Features

- Integrated P-channel MOSFET load switch
- Input voltage: 1.2V to 5.5V
- 3A maximum continuous switch current
- Switch on-resistance(typ.):
Rdson=24mΩ at VIN=5.5V
Rdson=29mΩ at VIN=3.3V
Rdson=73mΩ at VIN=1.2V
- Controlled slew rate to limit inrush currents
- Ultra low shutdown current
- Internal EN pull-down resistor
- WLCSP 1.355mm×0.855mm×0.55mm-6B

General Description

The AW35132 is a load switch with output slew rate control. The device integrates a 29mΩ (typ.) P-channel MOSFET, which can operate over a wide input range of 1.2V to 5.5V.

The AW35132 features output slew rate control, limiting inrush currents during turn-on to protect downstream devices.

Applications

Smart Wear

Vehicle Module

High-Definition Television(HDTV)

Typical Application Circuit

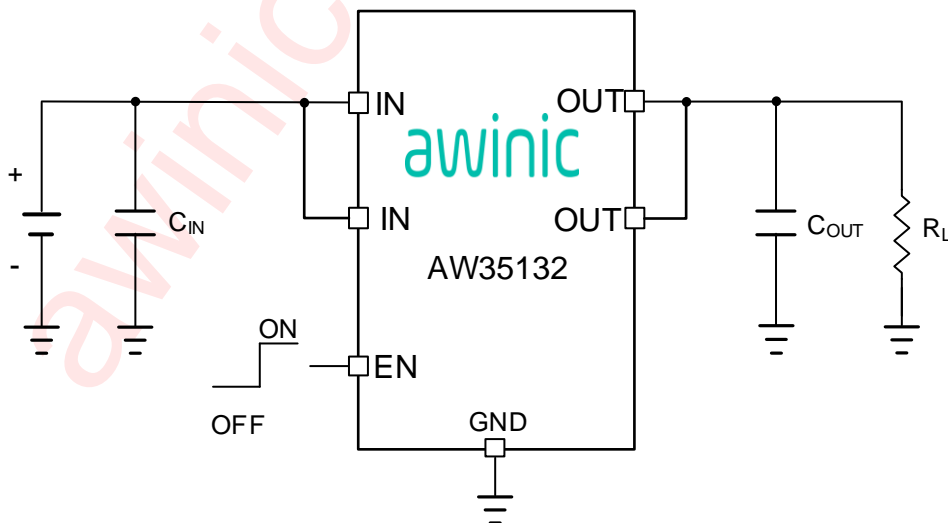

Figure 1 Typical Application circuit of AW35132

Pin Configuration And Top Mark

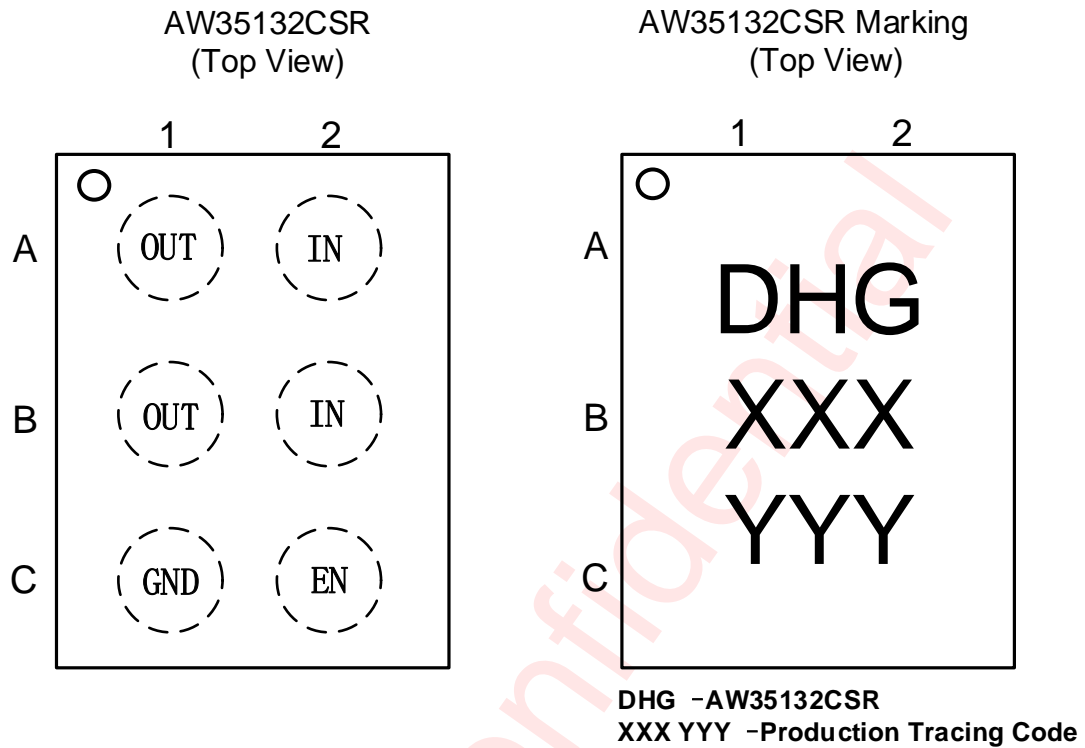

Figure 2 Pin Configuration and Top Mark

Pin Definition

Pin	Name	Description
A1	OUT	Switch output
B1		
C1	GND	Device ground
A2	IN	Switch input and power supply
B2		
C2	EN	Switch control input, active high

Functional Block Diagram

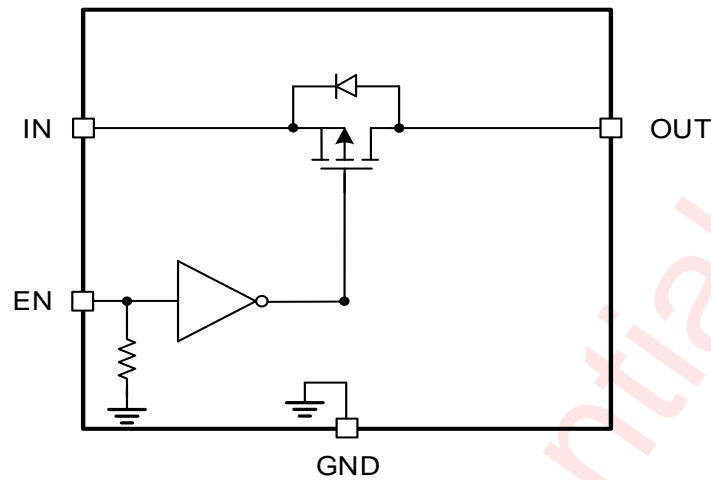

Figure 3 Functional Block Diagram

Typical Application Circuits

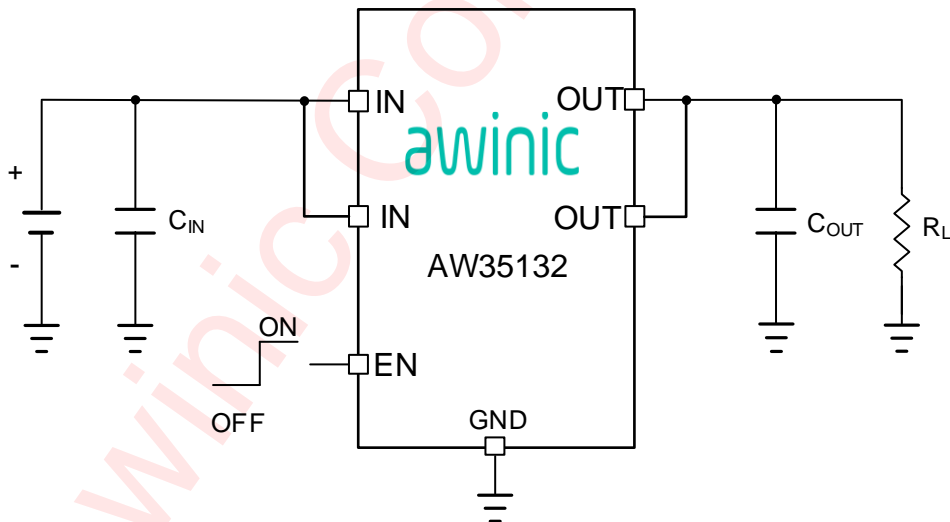

Figure 4 Typical Application circuit of AW35132

Ordering Information

Part Number	Temperature	Package	Marking	Moisture Sensitivity Level	Environmental Information	Delivery Form
AW35132CSR	-40°C~85°C	WLCSP 1.355mm×0.85 5mm×0.55mm -6B	DHG	MSL1	ROHS+HF	4500 units/ Tape and Reel

Absolute Maximum Ratings^(NOTE1)

PARAMETERS		RANGE
Supply Voltage Range V_{IN}		-0.3V to 6V
Enable Voltage Range	EN	-0.3V to 6V
Output Voltage Range	OUT	-0.3V to 6V
Maximum Continuous Switch Current for $V_{IN} \geq 1.5V$		3A
Maximum Continuous Switch Current for $1.2 \leq V_{IN} < 1.5V$ ^(NOTE 2)		2.5A
Maximum Peak Switch Current for $V_{IN} \geq 2.5V$ ^(NOTE 3)		4A
Junction-to-ambient Thermal Resistance θ_{JA} ^(NOTE 4)		100°C/W
Operating Free-air Temperature Range		-40°C to 85°C
Maximum Junction Temperature T_{JMAX}		150°C
Storage Temperature T_{STG}		-65°C to 150°C
Lead Temperature (Soldering 10 Seconds)		260°C
ESD		
HBM (Human Body Model) ^(NOTE 5)		±2kV
CDM (Charged Device Model) ^(NOTE 6)		±1.5kV
Latch-Up		
Latch-Up ^(NOTE 7)		+IT: 200mA -IT: -200mA

NOTE1: Conditions out of those ranges listed in "absolute maximum ratings" may cause permanent damages to the device. In spite of the limits above, functional operation conditions of the device should be within the ranges listed in "recommended operating conditions". Exposure to absolute-maximum-rated conditions for prolonged periods may affect device reliability.

NOTE2: The power mos enters saturation region, load capacity is reduced.

NOTE3: Limited by thermal design, and tested in 10ms width pulse current.

NOTE4: Thermal resistance from junction to ambient is highly dependent on PCB layout.

NOTE5: The human body model is a 100pF capacitor discharged through a 1.5kΩ resistor into each pin. Test method: ESDA/JEDEC JS-001-2017.

NOTE6: All pins. Test Condition: ESDA/JEDEC JS-002-2018.

NOTE7: Test Condition: JESD78E.

Recommended Operating Conditions

Symbol	Parameter	Min.	Typ.	Max.	Unit
V_{IN}	Input Voltage	1.2		5.5	V
V_{EN}	EN Voltage	0		5.5	V
V_{OUT}	Output Voltage	0		V_{IN}	V
C_{IN}	Input capacitance	0.1	1		μF
C_{OUT}	Output load capacitance	0.1	1		μF

Electrical Characteristics

$T_A = 25^\circ\text{C}$ unless otherwise noted. Typical values are guaranteed for $V_{IN} = 3.3\text{V}$, $C_{IN} = 1\mu\text{F}$, $I_{IN} \leq 3\text{A}$.

PARAMETER		TEST CONDITION	MIN	TYP	MAX	UNIT
INPUT CURRENTS						
I_Q	Input quiescent current	$V_{IN}=3.3\text{V}$, $V_{EN}=3.3\text{V}$, $I_{OUT}=0\text{A}$, $T_A=25^\circ\text{C}$		4	70	nA
		$V_{IN}=3.3\text{V}$, $V_{EN}=3.3\text{V}$, $I_{OUT}=0\text{A}$, $T_A=85^\circ\text{C}$		8		nA
		$V_{IN}=5.5\text{V}$, $V_{EN}=5.5\text{V}$, $I_{OUT}=0\text{A}$, $T_A=25^\circ\text{C}$		6	90	nA
		$V_{IN}=5.5\text{V}$, $V_{EN}=5.5\text{V}$, $I_{OUT}=0\text{A}$, $T_A=85^\circ\text{C}$		45		nA
I_{SD}	Shutdown current from IN to GND	$V_{IN}=1.2\text{V}$, $V_{EN}=0\text{V}$, $T_A=25^\circ\text{C}$		7	35	nA
		$V_{IN}=1.8\text{V}$, $V_{EN}=0\text{V}$, $T_A=25^\circ\text{C}$		8	40	nA
		$V_{IN}=3.3\text{V}$, $V_{EN}=0\text{V}$, $T_A=25^\circ\text{C}$		12	90	nA
		$V_{IN}=3.3\text{V}$, $V_{EN}=0\text{V}$, $T_A=85^\circ\text{C}$		1000		nA
		$V_{IN}=4.5\text{V}$, $V_{EN}=0\text{V}$, $T_A=25^\circ\text{C}$		20	130	nA
		$V_{IN}=5.5\text{V}$, $V_{EN}=0\text{V}$, $T_A=25^\circ\text{C}$		45	200	nA
		$V_{IN}=5.5\text{V}$, $V_{EN}=0\text{V}$, $T_A=85^\circ\text{C}$		1650		nA
I_{LEAKEN}	EN pin leakage current	$V_{IN}=0\text{V}$, $V_{EN}=5.5\text{V}$		355	800	nA
R_{EN}	EN pin pull down resistor	$V_{EN}=5.0\text{V}$		15.5		M Ω
POWER SWITCH						
R_{dson}	Internal switch MOSFET on-state resistance	$V_{IN}=5.5\text{V}$, $V_{EN}=\text{high}$, $I_{OUT}=200\text{mA}$, $T_A=25^\circ\text{C}$		24	30	m Ω
		$V_{IN}=3.3\text{V}$, $V_{EN}=\text{high}$, $I_{OUT}=200\text{mA}$, $T_A=25^\circ\text{C}$		29	40	
		$V_{IN}=1.8\text{V}$, $V_{EN}=\text{high}$, $I_{OUT}=200\text{mA}$, $T_A=25^\circ\text{C}$		44	60	
		$V_{IN}=1.2\text{V}$, $V_{EN}=\text{high}$, $I_{OUT}=200\text{mA}$, $T_A=25^\circ\text{C}$		73	90	
t_R	Output rise time	$V_{IN}=3.3\text{V}$, $C_{OUT}=1\mu\text{F}$, $R_{OUT}=5\Omega$		320		μs
t_F	Output fall time	$V_{IN}=3.3\text{V}$, $C_{OUT}=1\mu\text{F}$, $R_{OUT}=5\Omega$		10		μs
t_{ON}	Switch turn on time	$V_{IN}=3.3\text{V}$, $C_{OUT}=1\mu\text{F}$, $R_{OUT}=5\Omega$		360		μs
t_{OFF}	Switch turn off time	$V_{IN}=3.3\text{V}$, $C_{OUT}=1\mu\text{F}$, $R_{OUT}=5\Omega$		5		μs
t_{EN}	Enable time	$V_{IN}=3.3\text{V}$, $C_{OUT}=1\mu\text{F}$, $R_{OUT}=5\Omega$		210		μs
V_{IH}	EN input high threshold level		1.2			V
V_{IL}	EN input low threshold level				0.4	V

Timing Diagram

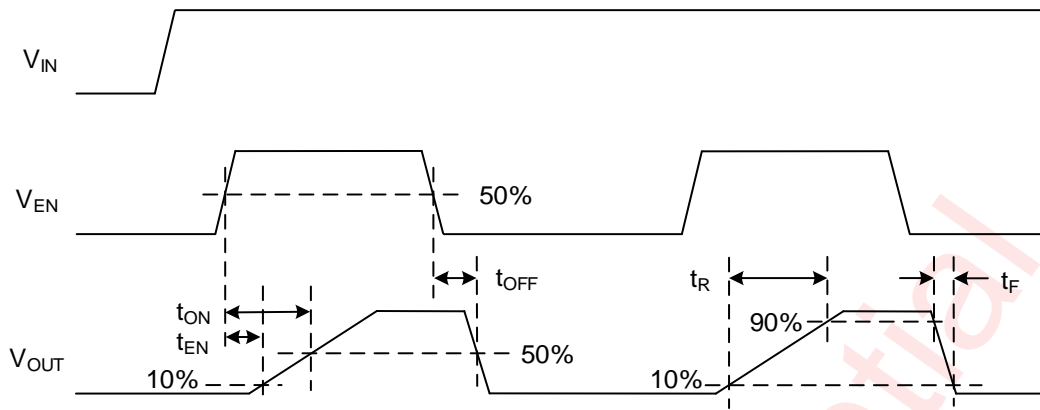

Figure 5 AW35132 Timing Diagram

Typical Characteristics

Ambient temperature is 25°C, $C_{IN} = C_{OUT} = 1\mu F$, unless otherwise noted.

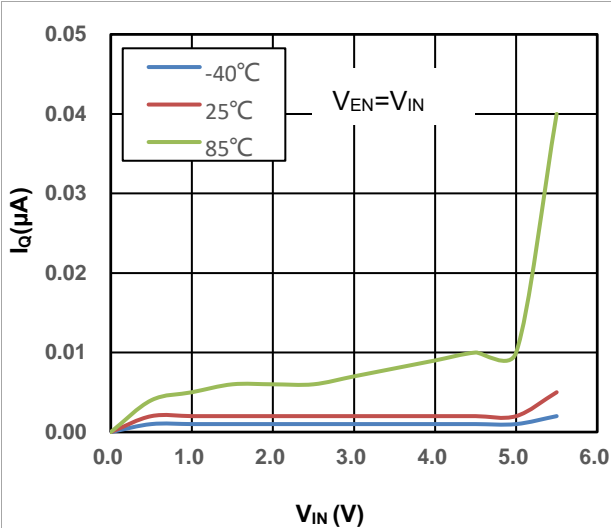

Figure 6 Quiescent Current vs. V_{IN} , No load

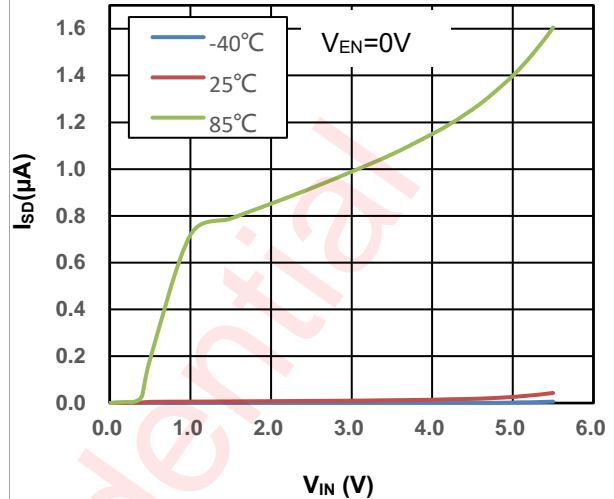

Figure 7 IN Shutdown Current vs. V_{IN}

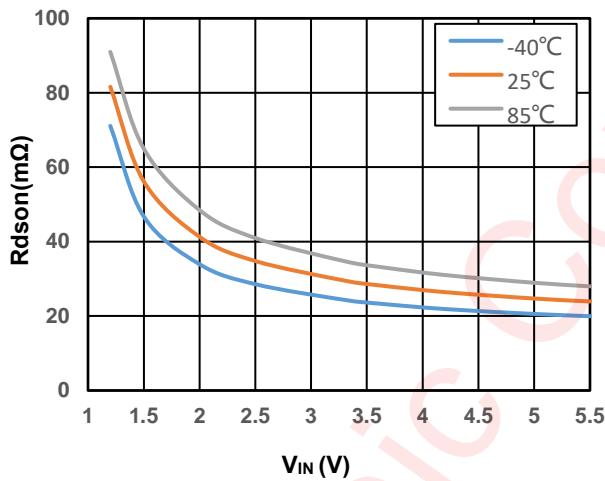

Figure 8 R_{dson} vs. V_{IN} ($I_{OUT} = 200mA$)

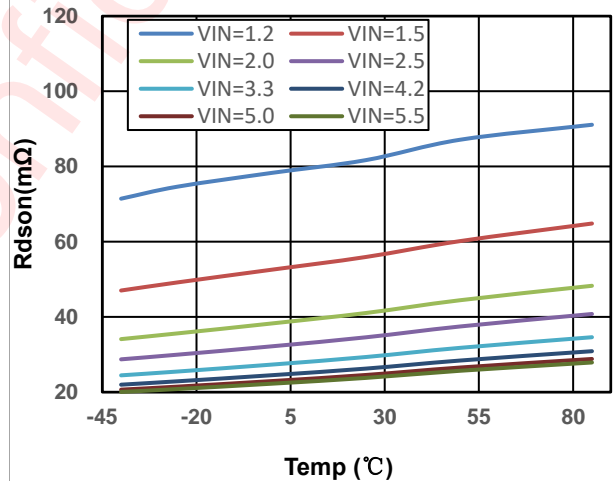

Figure 9 R_{dson} vs. Temperature ($I_{OUT} = 200mA$)

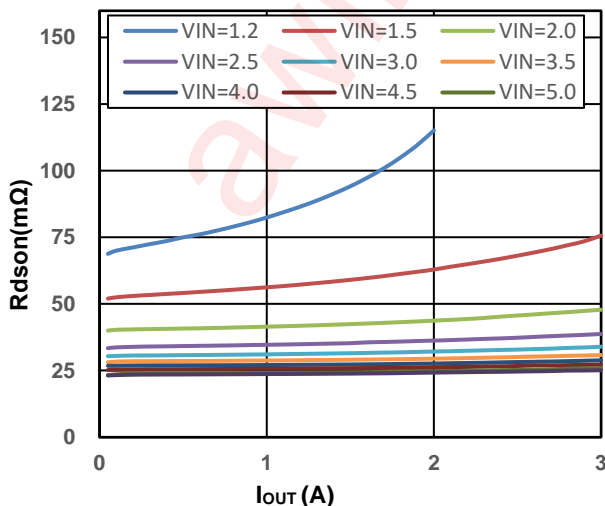

Figure 10 R_{dson} vs. I_{OUT}

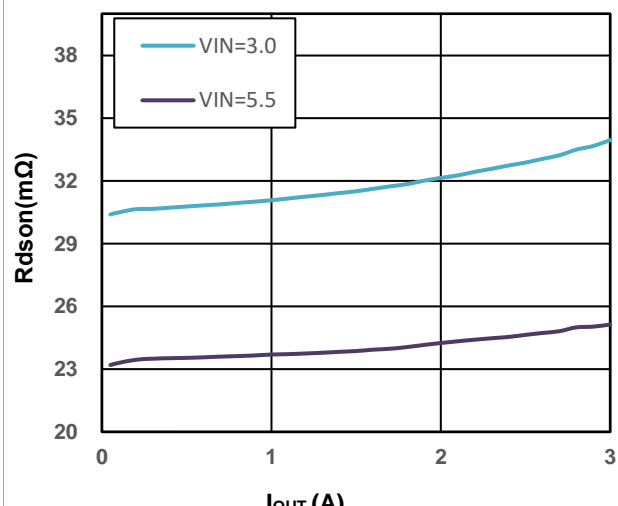

Figure 11 R_{dson} vs. I_{OUT}



C1: 2.00V/div C2: 2.00V/div t=160µs/div
C4: 2.00V/div
VIN=3.3V, CIN=1µF, COUT=1µF, Rload=5Ω

Figure 12 Turn On Response



C1: 2.00V/div C2: 2.00V/div t=5µs/div
C4: 2.00V/div
VIN=3.3V, CIN=1µF, COUT=1µF, Rload=5Ω

Figure 13 Turn Off Response



C1: 0.5V/div C2: 0.5V/div t=1.6ms/div
C4: 0.5V/div
VIN=1.2V, CIN=1µF, COUT=1µF, Rload=5Ω

Figure 14 Turn On Response

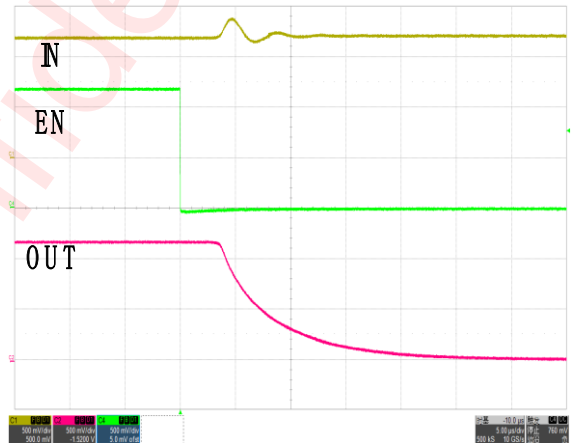

C1: 0.5V/div C2: 0.5V/div t=5µs/div
C4: 0.5V/div
VIN=1.2V, CIN=1µF, COUT=1µF, Rload=5Ω

Figure 15 Turn Off Response



C1: 2.00V/div C2: 2.00V/div t=160µs/div
C4: 2.00V/div
VIN=5.5V, CIN=1µF, COUT=1µF, Rload=5Ω

Figure 16 Turn On Response

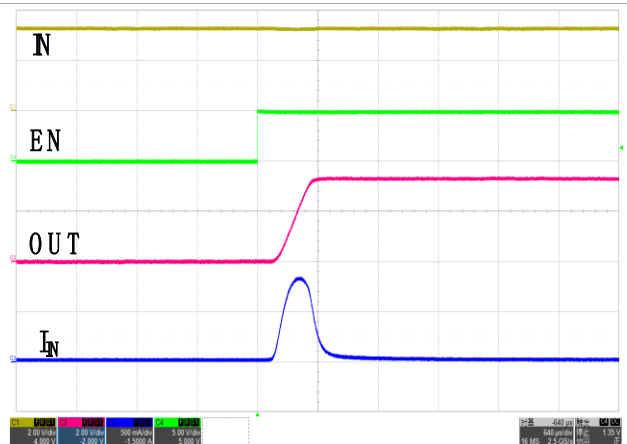

C1: 2.00V/div C2: 2.00V/div t=640µs/div
C3: 500mA/div C4: 5.00V/div
VIN=3.3V, CIN=1µF, COUT=100µF, no Rload

Figure 17 Inrush Current with COUT=100µF

Detailed Functional Description

The AW35132 integrates a high side P channel MOSFET load switch, and provides a low on-resistance for a low voltage drop across the device. A controlled slew rate is used in applications to limit the inrush current. The part can be turned on, with a supply voltage from 1.2V to 5.5V.

Turn On/Off Control

Enable pin is an active high. The device is opened when EN pin is tied low (disable) or pulled down by internal 15.5MΩ resistor, forcing PMOS switch off. The IN/OUT path is activated with a minimum of V_{in} of 1.2V and EN forced to high level.

Table 1. Functional Table

EN	IN to OUT	OUT to GND
Low	OFF	OFF
High	ON	OFF

Slew Rate Control

When the switch is enabled, the device regulates the gate voltage of MOSFET, and controls the V_{OUT} slew rate during t_R to avoid a large input inrush current. The feature reduces the interference to the power supply.

PCB Layout Consideration

AW35132 is a low ON-Resistance load switch, to obtain the optimal performance, PCB layout should be considered carefully. Here are some guidelines:

1. All the peripherals should be placed as close to the device as possible. Place the input capacitor C_{IN} on the top layer (same layer as the AW35132) and close to IN pin, and place the output capacitor C_{OUT} on the top layer (same layer as the AW35132) and close to OUT pin.
2. The AW35132 integrate an up to 3A rated PMOS FET, and the PCB design rules must be respected to properly evacuate the heat out of the silicon. By increasing PCB area, especially around IN and OUT pins, the $R_{\theta JA}$ of the package can be decreased, allowing higher power dissipation. Red bold paths on Figure 18 are power lines that will flow large current, please route them on PCB as straight, wide and short as possible.
3. Use rounded corners on the power trace from the power supply connector to AW35132 to decrease EMI coupling.

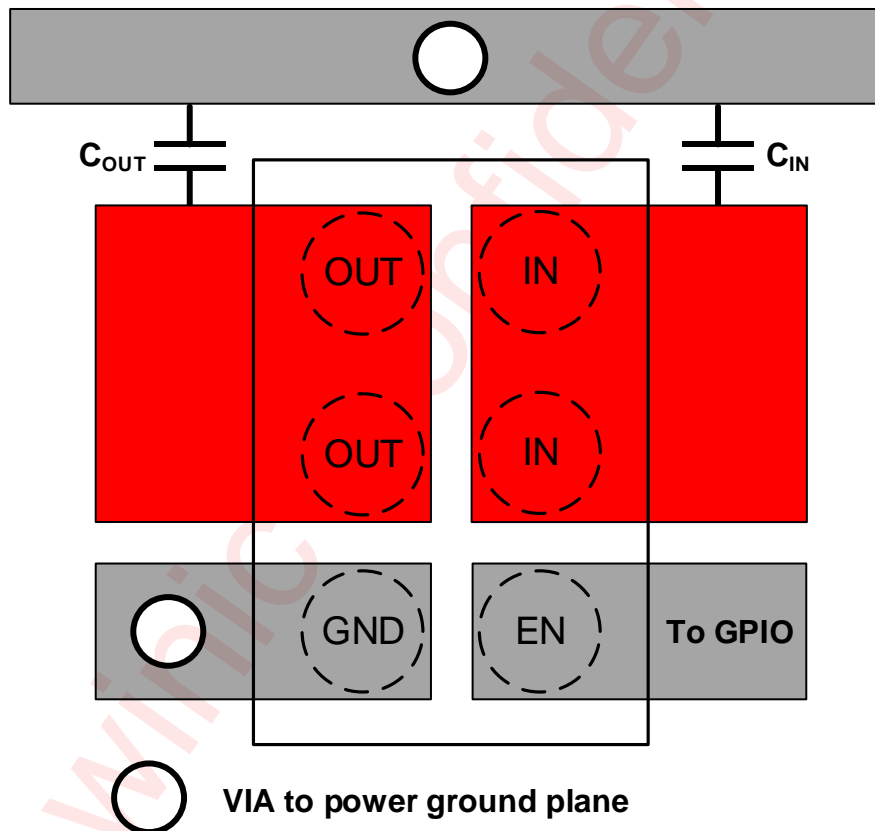
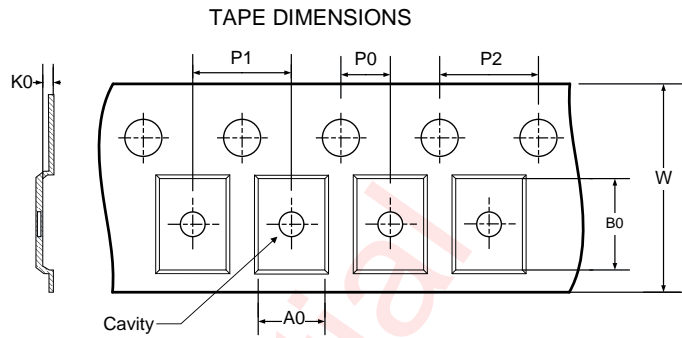
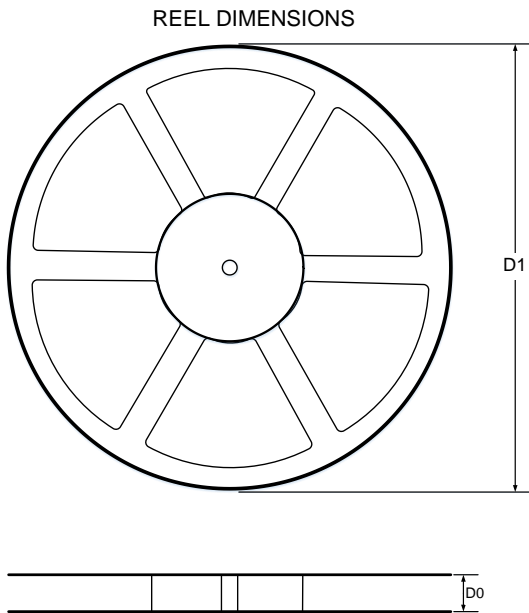

Figure 18 PCB layout example

Tape And Reel Information



- A0: Dimension designed to accommodate the component width
- B0: Dimension designed to accommodate the component length
- K0: Dimension designed to accommodate the component thickness
- W: Overall width of the carrier tape
- P0: Pitch between successive cavity centers and sprocket hole
- P1: Pitch between successive cavity centers
- P2: Pitch between sprocket hole
- D1: Reel Diameter
- D0: Reel Width

QUADRANT ASSIGNMENTS FOR PIN 1 ORIENTATION IN TAPE

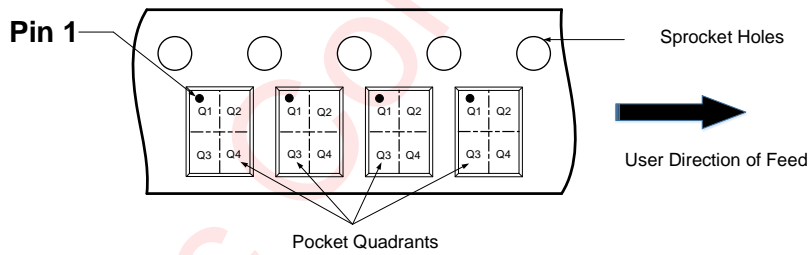

DIMENSIONS AND PIN1 ORIENTATION

D1 (mm)	D0 (mm)	A0 (mm)	B0 (mm)	K0 (mm)	P0 (mm)	P1 (mm)	P2 (mm)	W (mm)	Pin1 Quadrant
179.00	9.00	0.95	1.45	0.65	2.00	4.00	4.00	8.00	Q1

All dimensions are nominal

Package Description

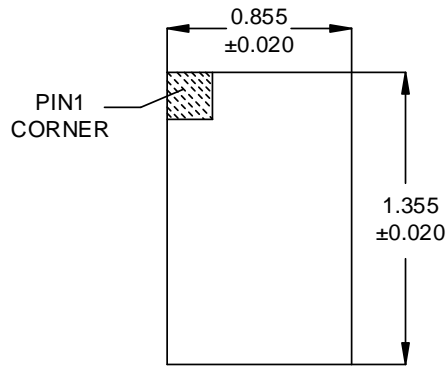

Top View

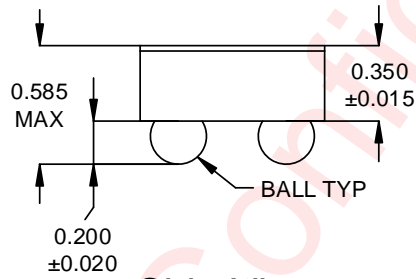

Side View

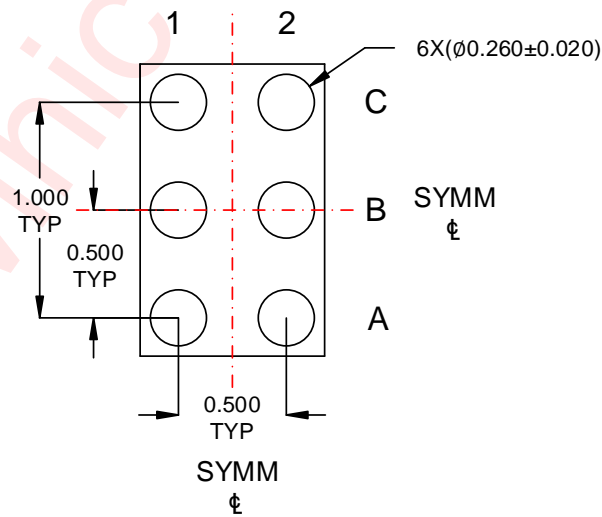

Bottom View

Unit: mm

Land Pattern Data

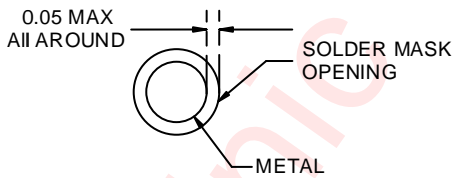
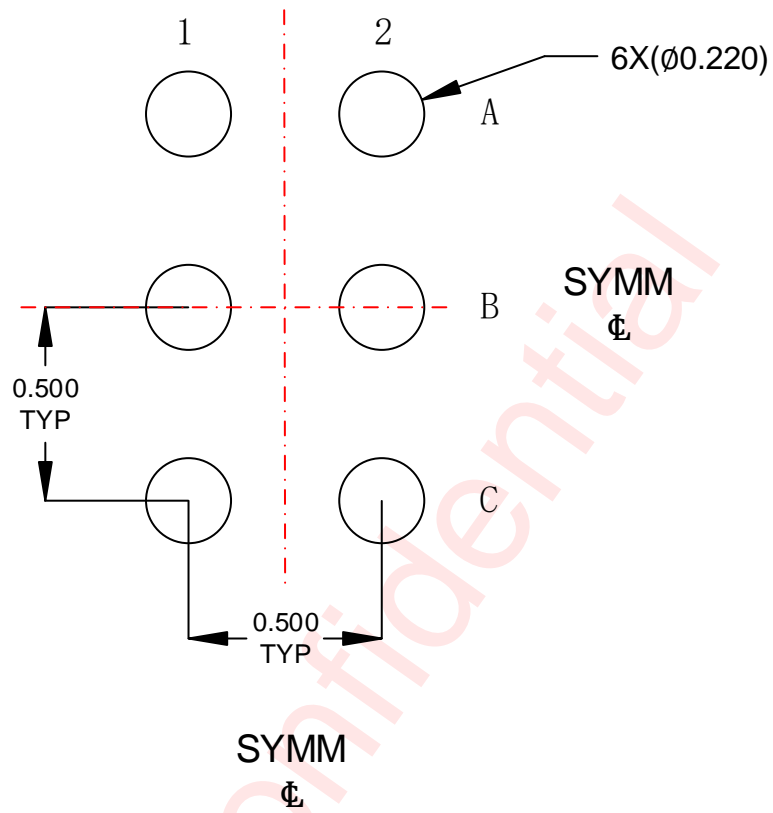

NON-SOLDER MASK DEFINED

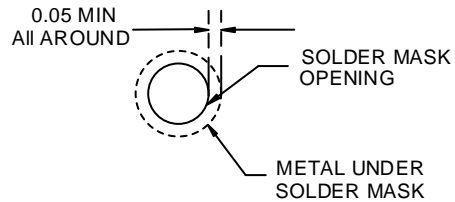

SOLDER MASK DEFINED

Unit: mm

Revision History

Version	Date	Change Record
V1.0	October 2020	Datasheet V1.0 Released

awinic Confidential

Disclaimer

All trademarks are the property of their respective owners. Information in this document is believed to be accurate and reliable. However, Shanghai AWINIC Technology Co., Ltd (AWINIC Technology) does not give any representations or warranties, expressed or implied, as to the accuracy or completeness of such information and shall have no liability for the consequences of use of such information.

AWINIC Technology reserves the right to make changes to information published in this document, including without limitation specifications and product descriptions, at any time and without notice. Customers shall obtain the latest relevant information before placing orders and shall verify that such information is current and complete. This document supersedes and replaces all information supplied prior to the publication hereof.

AWINIC Technology products are not designed, authorized or warranted to be suitable for use in medical, military, aircraft, space or life support equipment, nor in applications where failure or malfunction of an AWINIC Technology product can reasonably be expected to result in personal injury, death or severe property or environmental damage. AWINIC Technology accepts no liability for inclusion and/or use of AWINIC Technology products in such equipment or applications and therefore such inclusion and/or use is at the customer's own risk.

Applications that are described herein for any of these products are for illustrative purposes only. AWINIC Technology makes no representation or warranty that such applications will be suitable for the specified use without further testing or modification.

All products are sold subject to the general terms and conditions of commercial sale supplied at the time of order acknowledgement.

Nothing in this document may be interpreted or construed as an offer to sell products that is open for acceptance or the grant, conveyance or implication of any license under any copyrights, patents or other industrial or intellectual property rights.

Reproduction of AWINIC information in AWINIC data books or data sheets is permissible only if reproduction is without alteration and is accompanied by all associated warranties, conditions, limitations, and notices. AWINIC is not responsible or liable for such altered documentation. Information of third parties may be subject to additional restrictions.

Resale of AWINIC components or services with statements different from or beyond the parameters stated by AWINIC for that component or service voids all express and any implied warranties for the associated AWINIC component or service and is an unfair and deceptive business practice. AWINIC is not responsible or liable for any such statements.