

Inductorless, Single Channel 1.5A Flash LED Driver

FEATURES

- 1.5A Accurate and Programmable LED Current Source
 - Flash: 5.86mA~1.5A, 256 levels
5.86mA/level
 - Torch: 1.46mA~375mA, 256 levels
1.46mA/level
 - Flash Timeout: 40ms~1.6s, 16 levels
- Optimized Flash LED Current During Low Battery Conditions (IVFM)
- Grounded Cathode LED Operation for Improved Thermal Management
- Small Total Solution Size: < 4mm²
- Hardware Strobe Enable (STROBE)
- Input Voltage Range from 2.7V to 5.5V
- 400kHz I²C: AW36428 (I²C Address=0x63)
- 0.4mm Pitch, FCQFN-10L Package

APPLICATION

Smartphone Camera Flash

GENERAL DESCRIPTION

The AW36428 is a inductorless single channel 1.5A Flash LED driver that provides a high level of adjustability within a ultra-small solution size. The AW36428 can produce up to 1.5 A of LED flash current or up to 375 mA of torch current. The AW36428 provides IVFM protection mode to prevent system reset or shutdown under low battery condition.

The AW36428 is controlled via an I²C-compatible interface. The main features of the AW36428 include: flash / torch / IR current, flash timeout duration and IVFM. The AW36428 also provides hardware flash pin (STROBE) to control flash event.

The device operates over a -40°C to +85°C ambient temperature range.

The AW36428 is available in small 0.4mm pitch 1.6mmx1.2mm FCQFN-10L package.

TYPICAL APPLICATION CIRCUIT

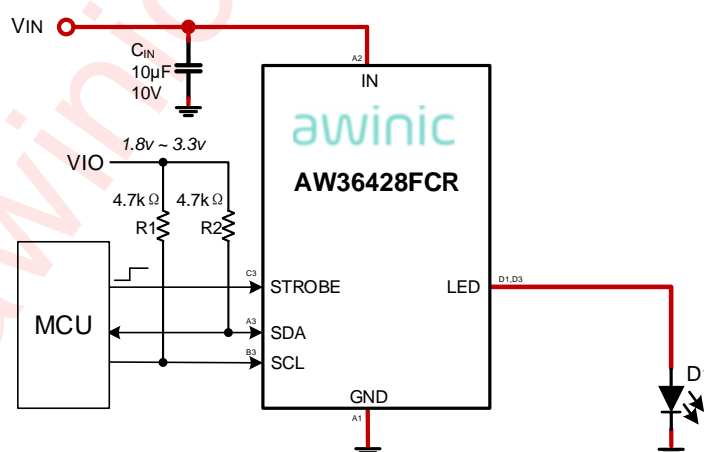
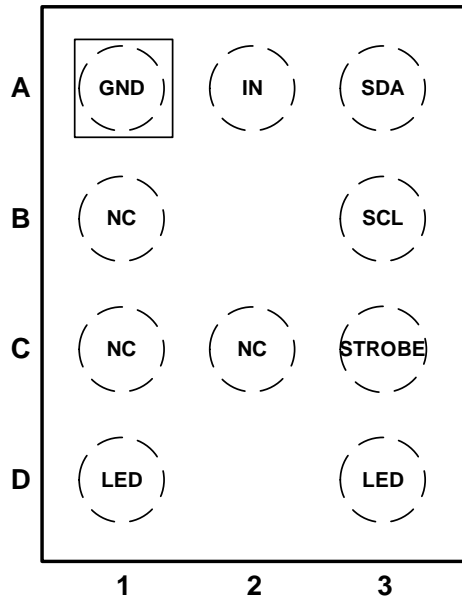
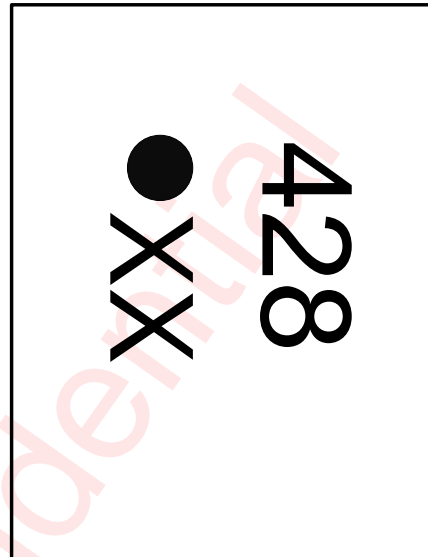

Fig 1 Typical Application Circuit of AW36428

All trademarks are the property of their respective owners.

PIN CONFIGURATION AND TOP MARK

AW36428FCR Pin Configuration
(Top View)AW36428FCR Top Mark
(Top View)

428 – AW36428FCR
XX – Manufacture Tracking Code

Fig 2 Pin Configuration and Top Mark

PIN DEFINITION

No.	NAME	TYPE	DESCRIPTION
A1	GND	Ground	Ground
A2	IN	Power	Input voltage connection. Connect IN to GND with a 10 μ F or larger ceramic capacitor.
A3	SDA	I/O	Serial data input/output of the I ² C interface.
B1	NC	I/O	No Connect. Must be floating, for chip test.
B3	SCL	I/O	Serial clock input of the I ² C interface.
C1,C2	NC	I/O	No Connect. Must be floating, for chip test.
C3	STROBE	I/O	Active high hardware flash enable. Drive STROBE high to turn on Flash pulse. Internal pull down resistor of 300k Ω between STROBE and GND.
D1	LED	Power	High-side current source output for flash LED, Connect pin D1 to D3 externally.
D3	LED	Power	High-side current source output for flash LED, Connect pin D1 to D3 externally.

ORDERING INFORMATION

Part Number	Temperature	Package	Marking	Moisture Sensitivity Level	Environmental Information	Delivery Form
AW36428FCR	-40°C~85°C	FCQFN-10L	428	MSL1	ROHS+HF	3000 units/ Tape and Reel

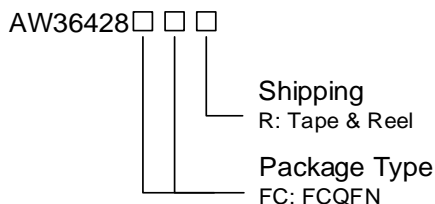

AWINIC FLASH LED DRIVER SERIES

Product	Channels	Type	Description	Package
AW3644	2	Boost	High Efficiency, Dual Independent 1.5A Flash LED Driver	CSP-12
AW36414	2	Boost	High Efficiency, Dual Independent 1.5A Flash LED Driver	CSP-12
AW3643	2	Boost	High Efficiency, Dual 1.5A Flash LED Driver	CSP-12
AW36413	2	Boost	High Efficiency, Dual 1.5A Flash LED Driver	CSP-12
AW3648	1	Boost	High Efficiency, 1.5A Flash LED Driver	CSP-12
AW3641E	1	Charge Pump	Flash Current & Flash Timer Programmable 1A Flash LED Driver	DFN-10
AW3640	1	Current Sink	200mA 1-Wire Configurable Front Flash LED Driver	DFN-6
AW36402	1	Current Sink	200mA 1-wire Configurable Front Flash LED Driver	DFN-6
AW36404	1	Current Sink	400mA 1-wire Configurable Front Flash LED Driver	DFN-8
AW36406	1	Current Sink	600mA PWM Configurable Front Flash LED Driver	DFN-8

TYPICAL APPLICATION CIRCUITS

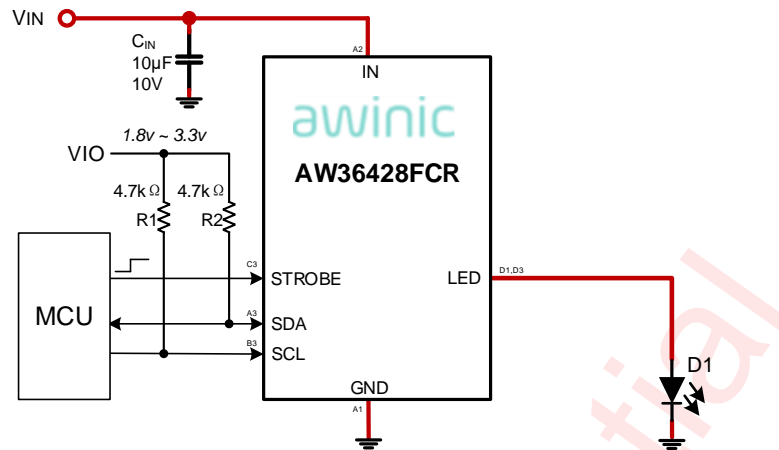

Fig 3 AW36428 Application Circuit

Notice for Typical Application Circuits:

1. Please place C_{IN} as close to the chip as possible.
2. For the sake of driving capability, the power lines, and the connection lines of LED should be short and wide as possible.

ABSOLUTE MAXIMUM RATINGS^(NOTE1)

PARAMETERS		Range	Unit
IN, LED		-0.3 to 6	V
SCL, SDA, STROBE		-0.3 to (V _{IN} +0.3)	V
Continuous power dissipation		Internally limited	
Max Junction Temperature T _{JMAX}		155	°C
Storage Temperature T _{STG}		-65 to 150	°C
Maximum lead temperature (soldering)		260	°C
Junction to Ambient Thermal Resistance θ_{JA}		92	°C/W
ESD, All Pins ^(NOTE2)	HBM	±2000	V
	MM	±200	V
	CDM	±2000	V
Latch-Up JEESD78D		+IT: +350 -IT: -350	mA

RECOMMENDED OPERATING CONDITIONS

PARAMETERS		Range	Unit
V _{IN}		2.7 to 5.5	V
Junction temperature (T _J)		-40 to 125	°C
Ambient temperature (T _A)		-40 to 85	°C

NOTE1: Conditions out of those ranges listed in "absolute maximum ratings" may cause permanent damages to the device. In spite of the limits above, functional operation conditions of the device should within the ranges listed in "recommended operating conditions". Exposure to absolute-maximum-rated conditions for prolonged periods may affect device reliability.

NOTE2: The human body model is a 100pF capacitor discharged through a 1.5kΩ resistor into each pin. Test method: MIL-STD-883J Method 3015.9

ELECTRICAL CHARACTERISTICS

Typical limits tested at $T_A=25^{\circ}\text{C}$. Minimum and maximum limits apply over the full operating ambient temperature range($-40^{\circ}\text{C}\leq T_A\leq 85^{\circ}\text{C}$). Unless otherwise specified, $V_{IN}=3.8\text{V}$.

Symbol	Description	Test Condition	Min	Typ	Max	Unit
Vin Supply						
V_{IN}	Input Operating Range		2.7		5.5	V
I_{SB}	Standby Supply Current	$2.7\text{V}\leq V_{IN}\leq 5.5\text{V}$, $SCL=SDA=0\text{V}$		1	2	μA
I_Q	Quiescent Supply Current			0.2	0.5	mA
$UVLO$	Under Voltage Lockout Threshold	Falling V_{IN}		2.5		V
		Rising V_{IN}		2.6		V
Current Source Specifications						
I_{LED}	Current Source Accuracy	Flash Code=0xAA=1.0A	-10%	1	10%	A
		Torch Code=0x7F=187.5mA	-10%	187.5	10%	mA
V_{HR_LED}	Headroom Voltage of LED	Flash Code=0xAA=1.0A		200	300	mV
		Torch Code=0x7F=187.5mA		50	75	mV
T_{FLASH}	Flash Time-out Duration	Reg 0x0B, bits[3:0]="1010"	-5%	600	5%	ms
V_{IVFM}	Input Voltage Flash Monitor Trip Threshold	Reg 0x02, bits[3:1]="000"	-3%	2.9	3%	V
T_{SD}	Thermal Shutdown Threshold			155		$^{\circ}\text{C}$
	Thermal Shutdown Hysteresis			20		
I²C-Compatible Interface Specifications(SCL,SDA)						
V_{IL}	Input Logic Low		0		0.4	V
V_{IH}	Input Logic High		1.2		V_{IN}	V
V_{OL}	Output Logic Low	$I_{LOAD}=3\text{mA}$			0.4	V
STROBE Voltage Specifications						
V_{IL}	Input Logic Low		0		0.4	V
V_{IH}	Input Logic High		1.2		V_{IN}	V
R_{PD}	Internal Pull Down Resistors			300		k Ω

I²C INTERFACE TIMING

Symbol	Description	Min	Typ	Max	Units
F _{SCL}	Interface Clock Frequency			400	kHz
T _{DEGLITCH}	Deglitch Time	SCL	200		ns
		SDA		250	ns
T _{HD:STA}	(Repeat-Start) Start Condition Hold Time	0.6			μs
T _{LOW}	Low Level Width of SCL	1.3			μs
T _{HIGH}	High Level Width of SCL	0.6			μs
T _{SU:STA}	(Repeat-Start) Start Condition Setup Time	0.6			μs
T _{HD:DAT}	Data Hold Time	0			μs
T _{SU:DAT}	Data Setup Time	0.1			μs
T _R	Rising Time of SDA And SCL			0.3	μs
T _F	Falling Time of SDA And SCL			0.3	μs
T _{SU:STO}	Stop Condition Setup Time	0.6			μs
T _{BUF}	Time Between Start and Stop Condition	1.3			μs

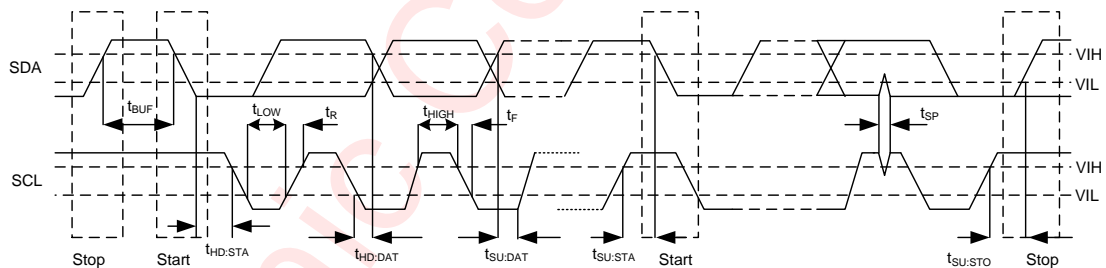
Fig 4 I²C INTERFACE TIMING

TYPICAL CHARACTERISTICS

Ta=25°C, VIN=3.8V, VLED=3.1V @ 1.5A, IVFM=Off, unless otherwise noted .

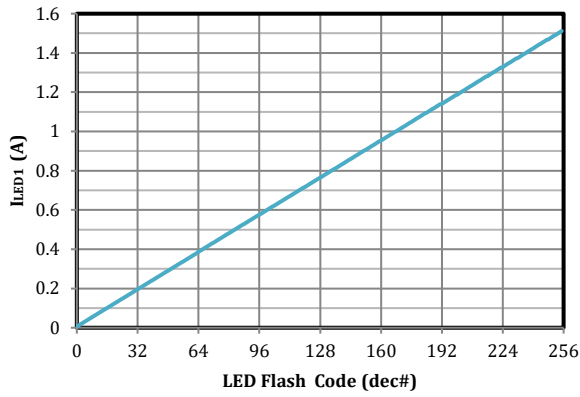

Fig 5. LED Flash Current vs Brightness Code

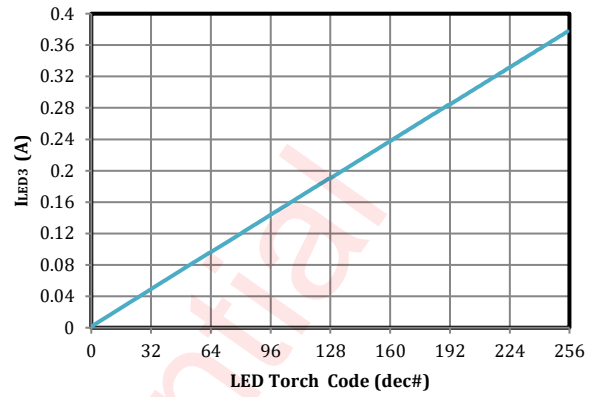

Fig 6. LED Torch Current vs Brightness Code

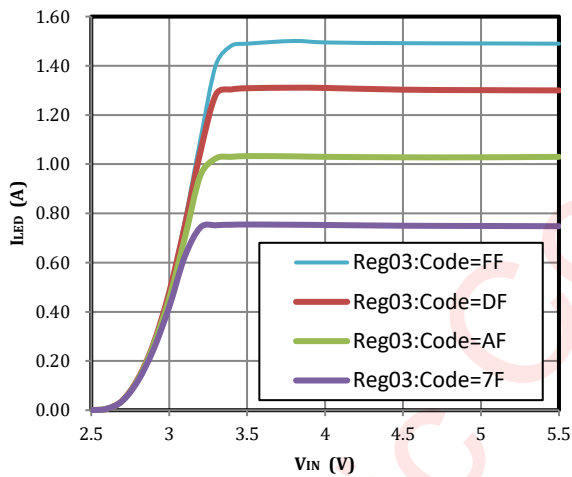

Fig7. LED Flash Current vs Input Voltage

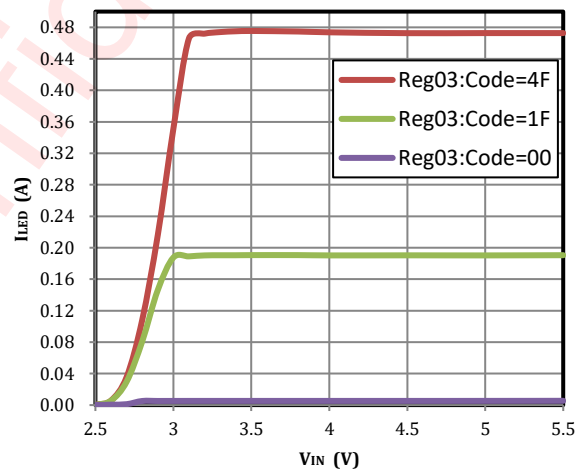

Fig 8. LED Flash Current vs Input Voltage

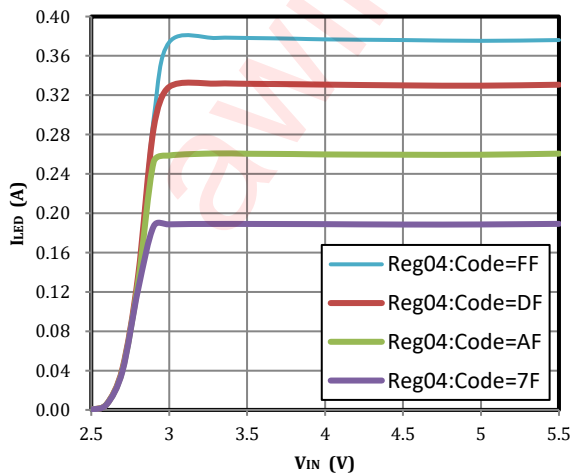

Fig 9. LED Torch Current vs Input Voltage

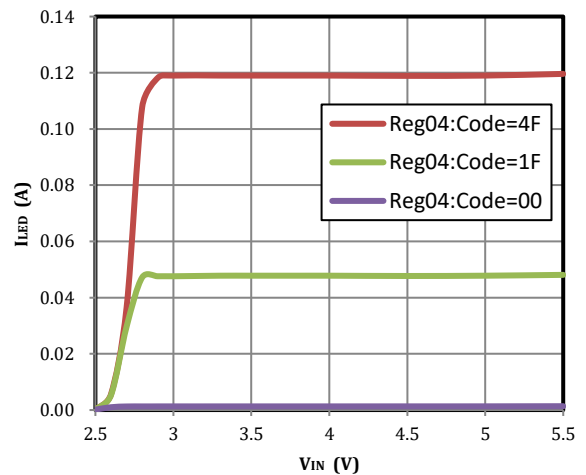

Fig 10. LED Torch Current vs Input Voltage

Typical Characteristics (continued)

Ta=25°C, VIN=3.8V, VLED=3.1V @ 1.5A, IVFM=Off, unless otherwise noted .

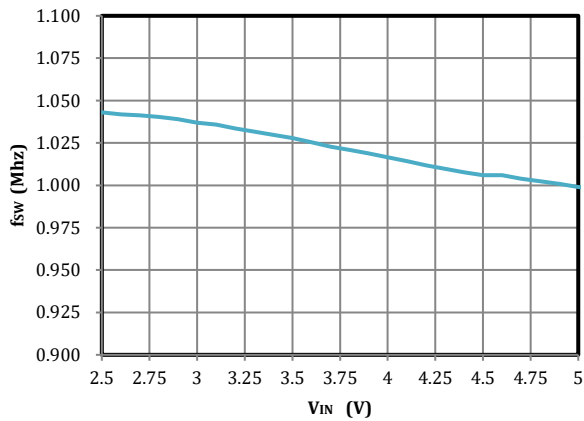

Fig 11. Oscillator Frequency vs Input Voltage

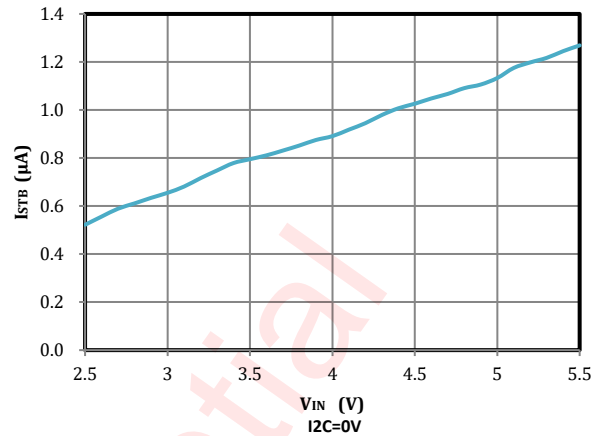

Fig 12. Standby Current vs Input Voltage

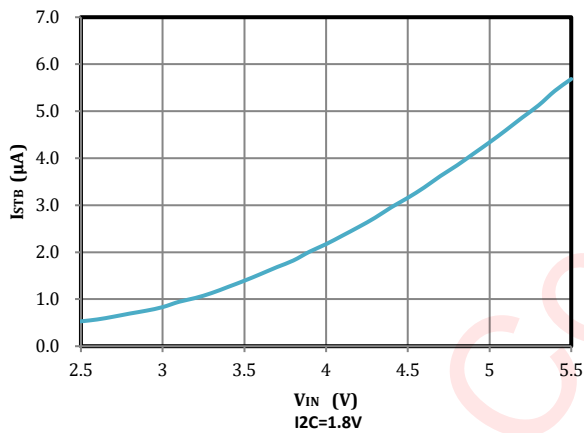

Fig 13. Standby Current vs Input Voltage

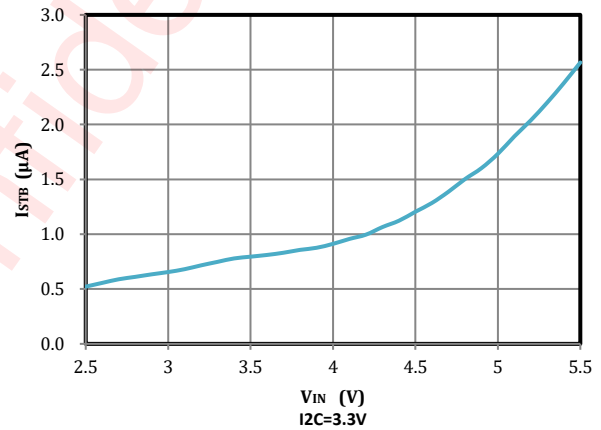
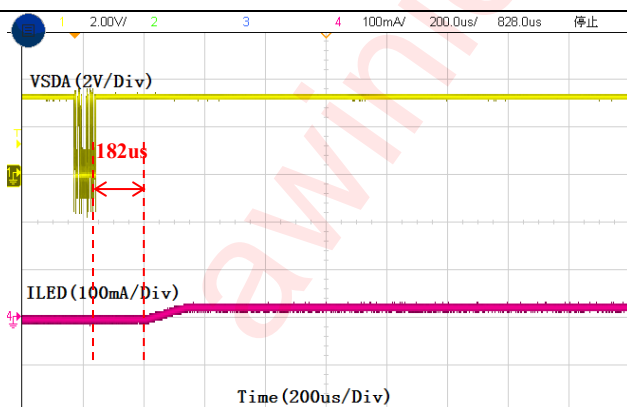
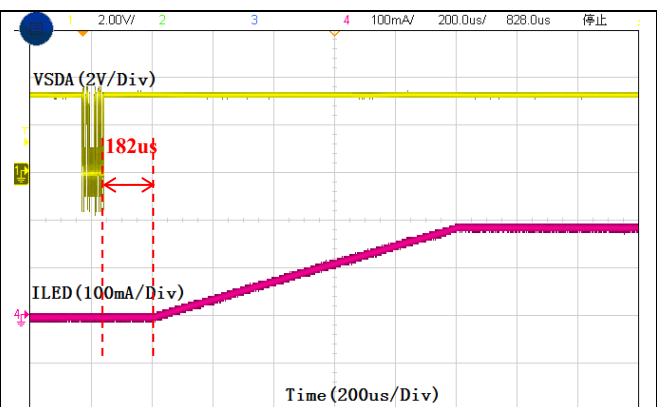

Fig 14. Standby Current vs Input Voltage



ILED=187.5mA, VIN=3.5V, IVFM=3.6V

Fig 15. IVFM ON



ILED=187.5mA, VIN=3.5V, IVFM=3.6V

Fig 16. IVFM OFF

Typical Characteristics (continued)

$T_a=25^{\circ}\text{C}$, $V_{IN}=3.8\text{V}$, $V_{LED}=3.1\text{V}$ @ 1.5A, IVFM=Off, unless otherwise noted .

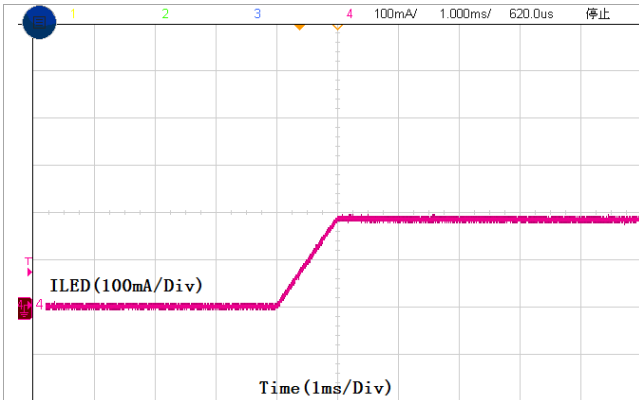

ILED=187.5mA

Fig 17. Flash Ramp up time

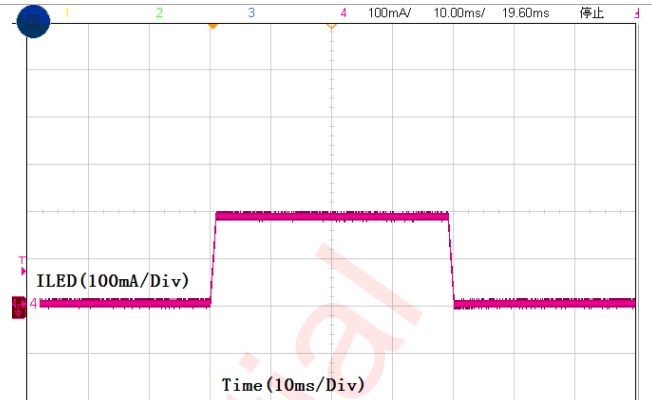

ILED=187.5mA Timeout=40ms(Reg0B(3:0)=0000)

Fig 18. Flash time out

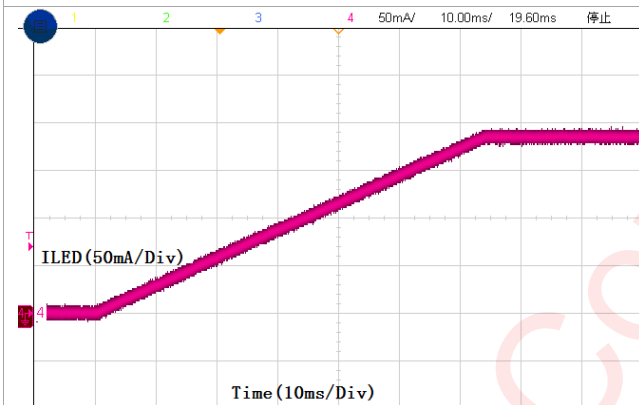

ILED=187.5mA Torch Ramp up=64ms(Reg0B(7:4)=0011)

Fig 19. Torch Ramp up time

DETAILED FUNCTIONAL DESCRIPTION

The AW36428 is a high-power LED flash driver capable of delivering up to 1.5A to the LED over the 2.7V to 5.5V input voltage range.

The device has one logic input for a hardware flash enable(STROBE). This logic input has an internal 300k Ω (typical) pull-down resistor to GND.

The device is controlled via an I²C-compatible interface which includes adjustment of the Flash and Torch current levels, changing the Flash Timeout Duration and IVFM level. Additionally, there are flag and status bits that indicate flash current timeout, LED over-temperature condition, LED failure (short), device thermal shutdown, and V_{IN} under-voltage conditions.

FUNCTION BLOCK DIAGRAM

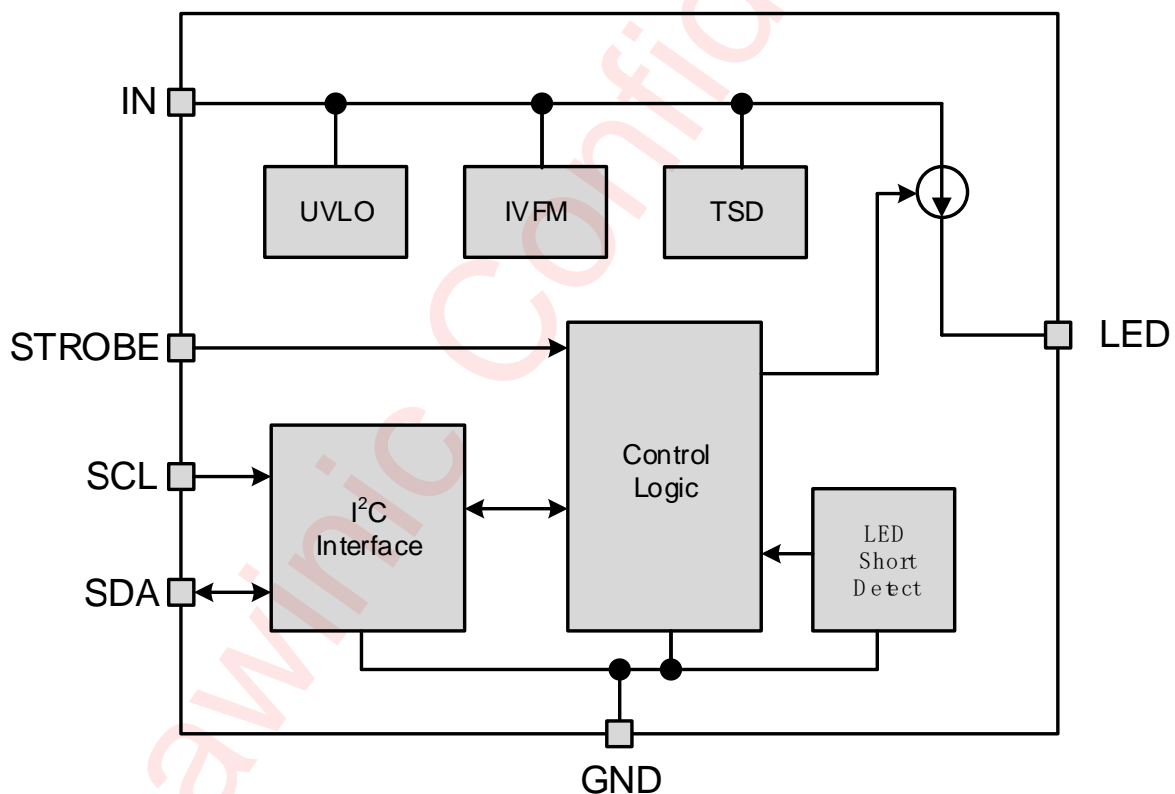

FEATURE DESCRIPTION

FLASH MODE

In Flash Mode, the LED current source provide 256 target current levels from 5.86mA to 1.5A. The Flash currents are adjusted via the LED Flash Brightness Register. Flash mode is activated by the Enable Register(setting M1, M0 to '11'), or by pulling the STROBE pin HIGH when the pin is enabled (Enable Register). Once the Flash sequence is activated, the current source LED ramp up to the programmed Flash current by stepping through all current steps until the programmed current is reached.

When the device is enabled in Flash Mode through the Enable Register, all mode bits in the Enable Register are cleared after a flash timeout event.

TORCH MODE

In Torch mode, the LED current source provide 256 target current levels from 1.46mA to 375mA. The Torch currents are adjusted via the LED Torch Brightness Register. Torch mode is activated by the Enable Register (setting M1, M0 to '10'). Once the TORCH sequence is activated, the active current source ramp up to the programmed Torch current by stepping through all current steps until the programmed current is reached. The rate at which the current ramps is determined by the value chosen in the Flash & Torch Timing Register (0x0B 7:4). Torch Mode is not affected by Flash Timeout.

IR MODE

In IR Mode, the target LED current is equal to the value stored in the LED Flash Brightness Register. When IR mode is enabled (setting M1, M0 to '01'), toggling the STROBE pin enables and disables the LED current sources (if enabled). The strobe pin can only be set to be Level sensitive, meaning all timing of the IR pulse is externally controlled. In IR Mode, the current sources do not ramp the LED output to the target. The current transitions immediately from off to on and then on to off.

SOFTWARE RESET

Writing 0x55 to Chip ID Register (register: 0x00) via I²C interface will reset the device, including all internal circuits and configuration registers. After the software reset command is input through I²C, it needs to wait at least 2ms before any other I²C command can be accepted.

INPUT VOLTAGE FLASH MONITOR (IVFM)

The AW36428 has the ability to adjust the flash current based upon the voltage level present at the IN pin utilizing the Input Voltage Flash Monitor (IVFM). The adjustable threshold ranges from 2.9 V to 3.6 V in 100mV steps, with hold mode. The IVFM threshold are controlled by bits[3:0] in the IVFM Register(0x02). The Flags Register has the IVFM flag bit set when the input voltage crosses the IVFM threshold value and after 4us deglitch delay. Additionally, the IVFM threshold sets the input voltage boundary that forces the AW36428 to either stop ramping the flash current after 32 steps ramp up during the startup.

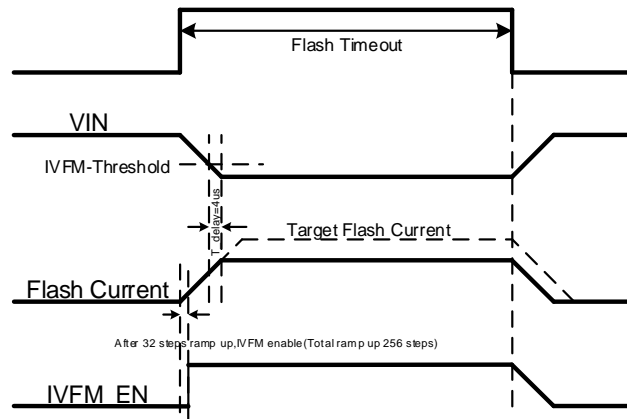

Fig 20 IVFM Timing

FLASH TIMEOUT

The Flash Timeout period sets the maximum time of one flash event, whether a flash stop command is received or not. The AW36428 has 16 timeout levels ranging from 40ms to 1.6s (see Flash & Torch TIMING CONFIGURATION REGISTER (0X0B) for more detail). Flash Timeout applies to both Flash and IR modes. The mode bits are cleared and bit[0] is set in the Flags register (0x0F) upon a Flash Timeout. This fault flag can be reset to '0' by reading back the Flags Register (0x0F), or by removing power to the AW36428.

UNDERVOLTAGE LOCKOUT (UVLO)

The AW36428 has an internal comparator that monitors the voltage at IN and forces the AW36428 into standby when the input voltage drops to 2.5 V. If the UVLO monitor threshold is tripped, the UVLO flag bit is set in the Flags Register (0x0F). If the input voltage rises above 2.5 V, the AW36428 is not available for operation until there is an I²C read of the Flags Register (0x0F). Upon a read, the Flags register is cleared, and normal operation can resume if the input voltage is greater than 2.5 V.

LED SHORT FAULT

The LED Short Fault flags read back a '1' if the device is active in Flash or Torch or IR mode and either active LED output experiences a short condition. An LED short condition is determined if the voltage at LED goes below 500mV (typ.) while the device is in Flash or Torch or IR mode. There is a deglitch time of 256 μ s before the LED Short Fault flag is valid. The mode bits are cleared upon an LED short fault. The AW36428 is not available for operation until the LED Short Fault flags is cleared. The LED Short Faults can be reset to '0' by reading back the Flags Register (0x0F), or by removing power to the AW36428.

THERMAL SHUTDOWN (TSD)

When the AW36428 die temperature reaches 155°C, the thermal shutdown detection circuit is tripped, forcing the AW36428 into standby and writing a '1' to the Thermal Shutdown Fault flag of the Flags Register (0x0F). The AW36428 is only allowed to restart after the Thermal Shutdown Fault flag is cleared. The Thermal Shutdown Faults can be reset to '0' by reading back the Flags Register (0x0F), or by removing power to the AW36428. Upon restart, if the die temperature is still above 155°C, the AW36428 resets the Fault flag and re-enters standby.

PROGRAMMING

I²C INTERFACE

Data Validation

When SCL is high level, SDA level must be constant. SDA can be changed only when SCL is low level.

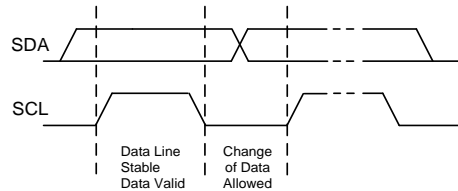

Fig 21 Data Validation Diagram

I²C Start/Stop

I²C start: SDA changes from high level to low level when SCL is high level.

I²C stop: SDA changes from low level to high level when SCL is high level.

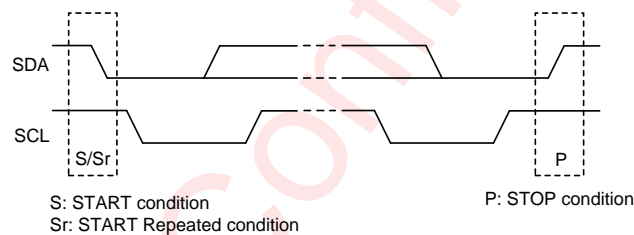

Fig 22 Start and Stop Conditions

ACK (Acknowledgement)

ACK means the successful transfer of I²C bus data. After master sends 8bits data, SDA must be released; SDA is pulled to GND by slave device when slave acknowledges.

When master reads, slave device sends 8bit data, releases the SDA and waits for ACK from master. If ACK is send and I²C stop is not send by master, slave device sends the next data. If ACK is not send by master, slave device stops to send data and waits for I²C stop.

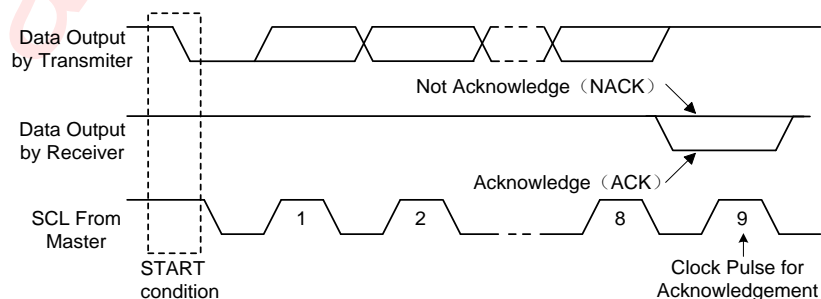

Fig 23 Acknowledgement Diagram

Write Cycle

One data bit is transferred during each clock pulse. Data is sampled during the high state of the serial clock (SCL). Consequently, throughout the clock's high period, the data should remain stable. Any changes on the SDA line during the high state of the SCL and in the middle of a transaction, aborts the current transaction. New data should be sent during the low SCL state. This protocol allows a single data line to transfer both command/control information and data using the synchronous serial clock.

Each data transaction is composed of a Start Condition, a number of byte transfers (set by the software) and a Stop Condition to terminate the transaction. Every byte written to the SDA bus must be 8 bits long and is transferred with the most significant bit first. After each byte, an Acknowledge signal must follow.

In a write process, the following steps should be followed:

- 1) Master device generates START condition. The "START" signal is generated by lowering the SDA signal while the SCL signal is high.
- 2) Master device sends slave address (7-bit) and the data direction bit (R/W = 0).
- 3) Slave device sends acknowledge signal if the slave address is correct.
- 4) Master sends control register address (8-bit)
- 5) Slave sends acknowledge signal
- 6) Master sends data byte to be written to the addressed register
- 7) Slave sends acknowledge signal
- 8) If master will send further data bytes the control register address will be incremented by one after acknowledge signal (repeat step 6, 7)
- 9) Master generates STOP condition to indicate write cycle end



Fig 24 I²C Write Timing

Read Cycle

In a read cycle, the following steps should be followed:

- 1) Master device generates START condition
- 2) Master device sends slave address (7-bit) and the data direction bit (R/W = 0).
- 3) Slave device sends acknowledge signal if the slave address is correct.
- 4) Master sends control register address (8-bit)
- 5) Slave sends acknowledge signal
- 6) Master generates STOP condition followed with START condition or REPEAT START condition
- 7) Master device sends slave address (7-bit) and the data direction bit (R/W = 1).
- 8) Slave device sends acknowledge signal if the slave address is correct.
- 9) Slave sends data byte from addressed register.
- 10) If the master device sends acknowledge signal, the slave device will increase the control register

address by one, then send the next data from the new addressed register.

11) If the master device generates STOP condition, the read cycle is ended.

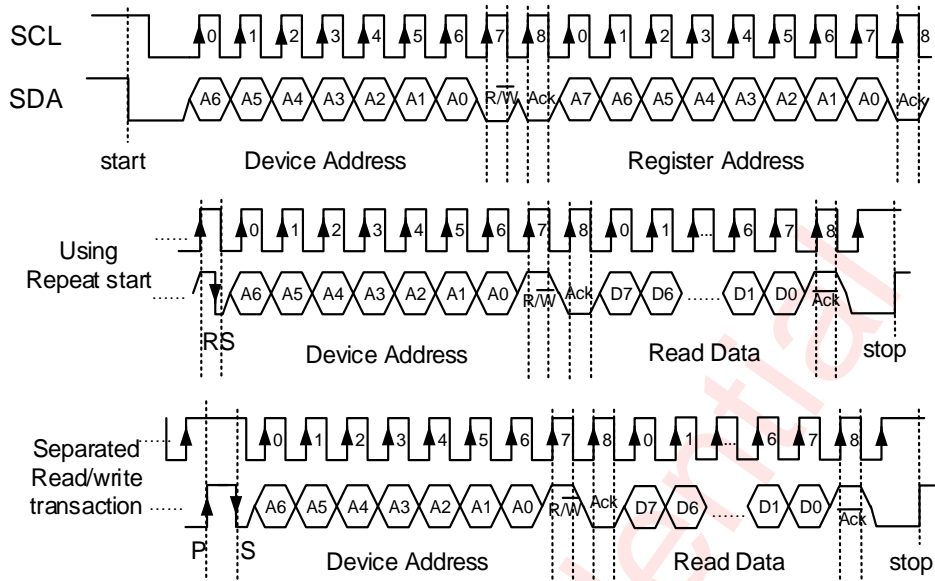

Fig 25 I²C Read Timing

REGISTER CONFIGURATION

REGISTER LIST

Register name	Address(HEX)	Read/Write	Default Value
Chip ID Register	0x00	Read	0x17
Enable Register	0x01	Read/Write	0x00
IVFM Register	0x02	Read/Write	0xE1
LED Flash Brightness Register	0x03	Read/Write	0x7F
LED Torch Brightness Register	0x04	Read/Write	0x7F
Flash & Torch Timing Register	0x0B	Read/Write	0x1A
Flags Register	0x0F	Read	0x00
Device ID Register	0x10	Read	0x98

REGISTER DETAILED DESCRIPTION

◇ Chip ID Register (0x00) , default(0x17)

Bit 7	Bit 6	Bit 5	Bit 4	Bit 3	Bit 2	Bit 1	Bit 0
Chip ID: "00010111"							
Write 55H To Reset All Registers							

◇ Enable Register (0x01) , default(0x00)

Bit 7	Bit 6	Bit 5	Bit 4	Bit 3	Bit 2	Bit 1	Bit 0
Strobe Type 0=Level Triggered (Default) 1=Edge Triggered	Strobe Enable 0=Disabled (Default) 1=Enabled	Mode Bits: M1, M0 00=Standby (Default) 01=IR Drive 10=Torch 11=Flash		RFU	RFU	RFU	LED Enable 0=OFF (Default) 1=ON

Note:

In Edge or Level Strobe Mode, it is recommended that the trigger pulse width be set greater than 1ms to ensure proper turn-on of the device.

◇ IVFM Register (0x02) , default(0xE1)

Bit 7	Bit 6	Bit 5	Bit 4	Bit 3	Bit 2	Bit 1	Bit 0
RFU	RFU	LED Pin Short Fault Detect 0=Disabled 1=Enabled (Default)	UVLO Enable 0=Disabled (Default) 1=Enabled	IVFM Levels 000=2.9 V (Default) 001=3.0 V 010=3.1 V 011=3.2 V 100=3.3 V 101=3.4 V 110=3.5 V 111=3.6 V			IVFM Enable 0=Disabled 1=Enabled (Default)

◇ LED Flash Brightness Register (0x03) , default(0x7F)

Bit 7	Bit 6	Bit 5	Bit 4	Bit 3	Bit 2	Bit 1	Bit 0
LED Flash Brightness Levels $I_{FLASH}(mA) \approx (Brightness\ Code * 5.86mA) + 5.86mA$ 00000000=5.86 mA 01111111=750 mA (Default) 11111111=1.5 A							

◇ LED Torch Brightness Register (0x04) , default(0x7F)

Bit 7	Bit 6	Bit 5	Bit 4	Bit 3	Bit 2	Bit 1	Bit 0
LED Torch Brightness Levels $I_{TORCH}(mA) \approx (Brightness\ Code * 1.46mA) + 1.46mA$ 00000000=1.46 mA 01111111=187.5 mA (Default) 11111111=375 mA							

✧ **Flash & Torch Timing Register (0x0B) , default(0x1A)**

Bit 7	Bit 6	Bit 5	Bit 4	Bit 3	Bit 2	Bit 1	Bit 0
Torch Current Ramp time 0000=No Ramp 0001=1 ms (Default) 0010=32 ms 0011=64 ms 0100=128 ms 0101=256 ms 0110=384 ms 0111=512 ms 1000=768 ms 1001=1024 ms 1010=1280 ms 1011=1536 ms 1100=1792 ms 1101=2048 ms 1110=2048 ms 1111=2048 ms				Flash Time-out Duration 0000=40 ms 0001=80 ms 0010=120 ms 0011=160 ms 0100=200 ms 0101=240 ms 0110=280 ms 0111=320 ms 1000=360 ms 1001=400 ms 1010=600 ms (Default) 1011=800 ms 1100=1000 ms 1101=1200 ms 1110=1400 ms 1111=1600 ms			

✧ **Flags Register (0x0F) , default(0x00)**

Bit 7	Bit 6	Bit 5	Bit 4	Bit 3	Bit 2	Bit 1	Bit 0
Flash Time-Out Flag	IVFM Trip Flag	RFU	RFU	RFU	LED Short Fault	Thermal Shutdown (TSD) Fault	UVLO Fault

✧ **Device ID Register (0x10) , default(0x98)**

Bit 7	Bit 6	Bit 5	Bit 4	Bit 3	Bit 2	Bit 1	Bit 0
Device ID: "1001 1000"							

PCB LAYOUT

LAYOUT GUIDELINES

The PCB layout of the high-power inductorless single channel LED driver AW36428 is important. The following steps should be used as a reference to ensure the device is stable and maintains proper LED current regulation across its intended operating voltage and current range.

1. Place CIN on the top layer (same layer as the AW36428) and as close to the device as possible. The input capacitor conducts the driver currents during LED turn on and can detect current spikes over 1.5A in amplitude. Connecting the input capacitor through short, wide traces to both the IN and GND pins reduces the inductive voltage spikes that occur during switching which can corrupt the VIN line.
2. For LED, terminate the Flash LED cathodes directly to the GND pin of the AW36428. If possible, route the LED returns with a dedicated path so as to keep the high amplitude LED currents out of the GND plane. For Flash LEDs that are routed relatively far away from the AW36428, a good approach is to sandwich the forward and return current paths over the top of each other on two layers. This helps reduce the inductance of the LED current paths.
3. To optimize the VIN operation range, the IN and GND wire should as short and wide as possible to reduce the series resistor. Meanwhile, To optimize the heat dissipation performance, the GND pins should be connected to the PCB ground plane using as many vias as possible.

PACKAGE DESCRIPTION

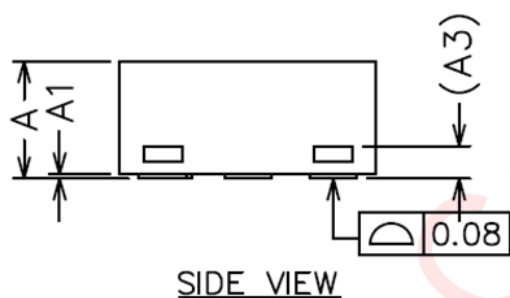
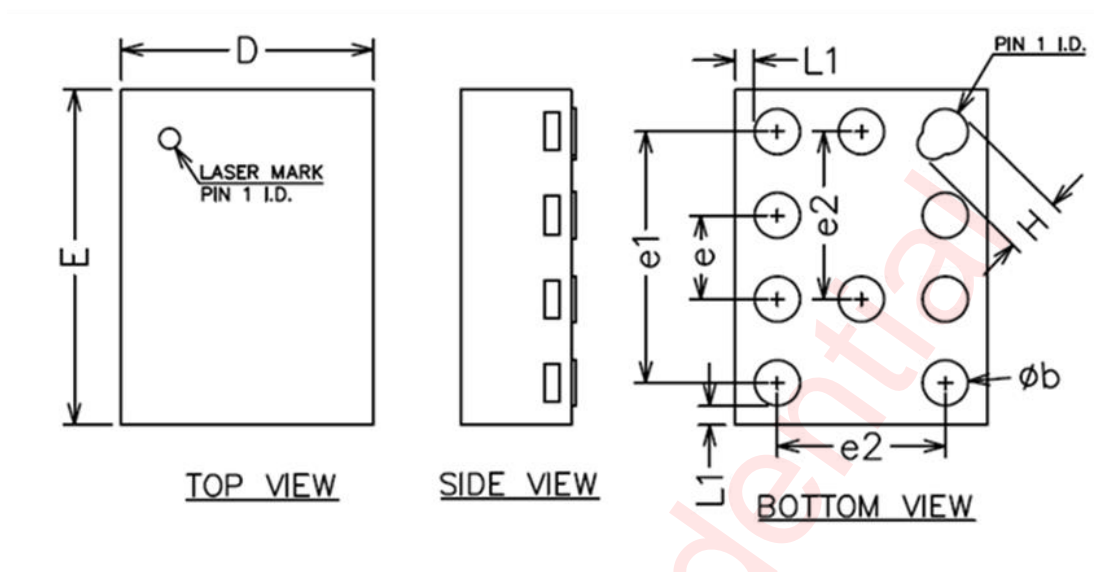
COMMON DIMENSIONS
(UNITS OF MEASURE=MILLIMETER)

SYMBOL	MIN	NOM	MAX
A	0.50	0.55	0.60
A1	0.00	0.02	0.05
A3	0.15REF		
b	0.17	0.22	0.27
D	1.10	1.20	1.30
E	1.50	1.60	1.70
e	0.40REF		
e1	1.20REF		
e2	0.80REF		
H	0.27REF		
L1	0.09REF		

LAND PATTERN

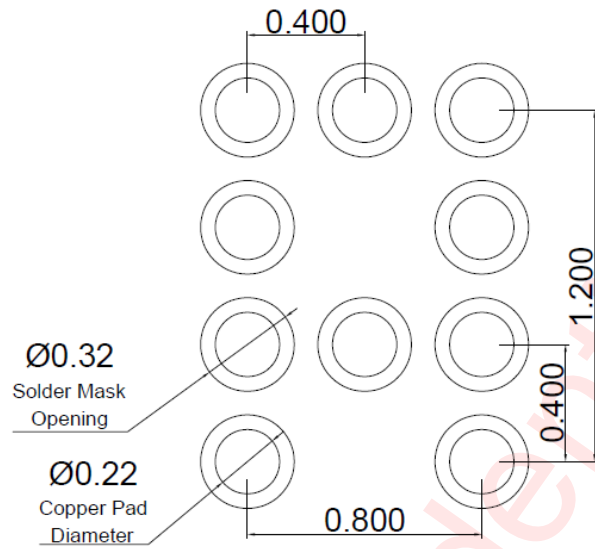

Dimensions are all in millimeters

REFLOW PROFILE

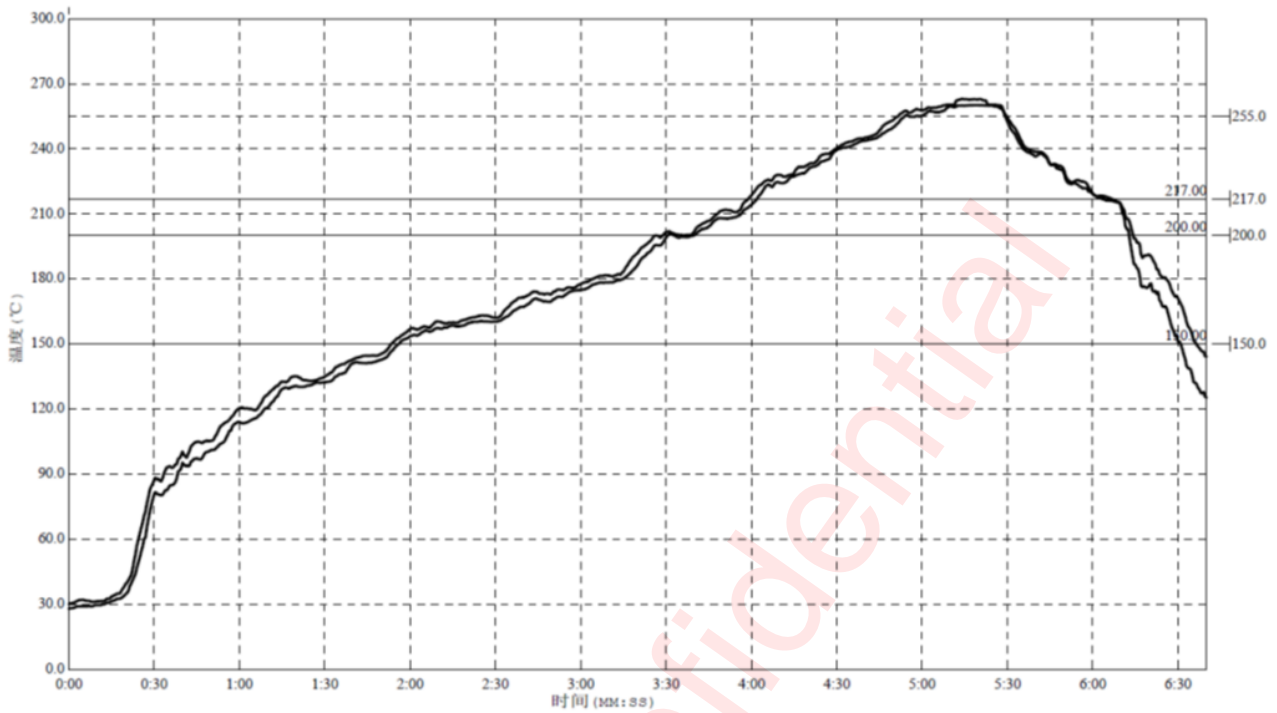

Reflow Note	Spec
Average ramp-up rate (217°C to peak)	Max. 3°C /sec
Time of Preheat temp. (from 150°C to 200°C)	60-120sec
Time to be maintained above 217°C	60-150sec
Peak Temperature	>260°C
Time within 5°C of actual peak temp	20-40sec
Ramp-down rate	Max. 6°C /sec
Time from 25°C to peak temp	Max. 8min

REVISION HISTORY

Version	Date	Change Record
V1.0	Oct 2017	Product Datasheet V1.0 Released
V1.1	Apr 2018	Product Datasheet V1.1 Released----add $V_{HR(max)}$ value
V1.2	Sep 2018	Correction NC pin definition Correction Package: FCQFN-10L
V1.3	July 2019	Added the Software Reset definition

awinic Confidential

DISCLAIMER

Information in this document is believed to be accurate and reliable. However, Shanghai AWINIC Technology Co., Ltd (AWINIC Technology) does not give any representations or warranties, expressed or implied, as to the accuracy or completeness of such information and shall have no liability for the consequences of use of such information.

AWINIC Technology reserves the right to make changes to information published in this document, including without limitation specifications and product descriptions, at any time and without notice. Customers shall obtain the latest relevant information before placing orders and shall verify that such information is current and complete. This document supersedes and replaces all information supplied prior to the publication hereof.

AWINIC Technology products are not designed, authorized or warranted to be suitable for use in medical, military, aircraft, space or life support equipment, nor in applications where failure or malfunction of an AWINIC Technology product can reasonably be expected to result in personal injury, death or severe property or environmental damage. AWINIC Technology accepts no liability for inclusion and/or use of AWINIC Technology products in such equipment or applications and therefore such inclusion and/or use is at the customer's own risk.

Applications that are described herein for any of these products are for illustrative purposes only. AWINIC Technology makes no representation or warranty that such applications will be suitable for the specified use without further testing or modification.

All products are sold subject to the general terms and conditions of commercial sale supplied at the time of order acknowledgement.

Nothing in this document may be interpreted or construed as an offer to sell products that is open for acceptance or the grant, conveyance or implication of any license under any copyrights, patents or other industrial or intellectual property rights.

Reproduction of AWINIC information in AWINIC data books or data sheets is permissible only if reproduction is without alteration and is accompanied by all associated warranties, conditions, limitations, and notices. AWINIC is not responsible or liable for such altered documentation. Information of third parties may be subject to additional restrictions.

Resale of AWINIC components or services with statements different from or beyond the parameters stated by AWINIC for that component or service voids all express and any implied warranties for the associated AWINIC component or service and is an unfair and deceptive business practice. AWINIC is not responsible or liable for any such statements.