

8-Channel Digital Output Module 24 V DC

Short-circuit protected; low-side switching

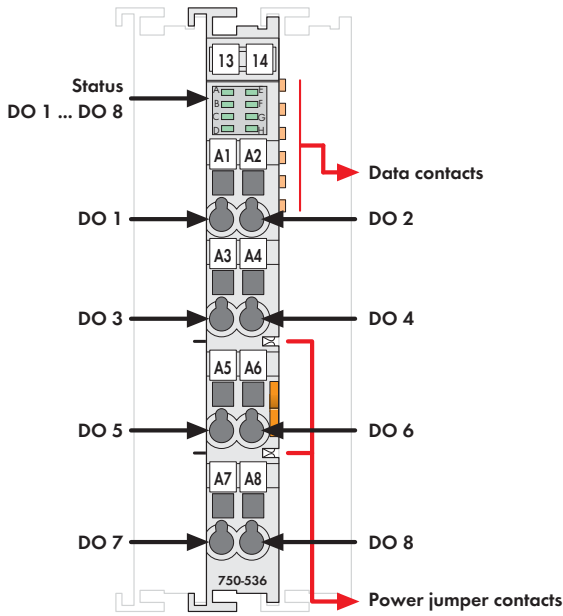

Delivered without miniature WSB markers

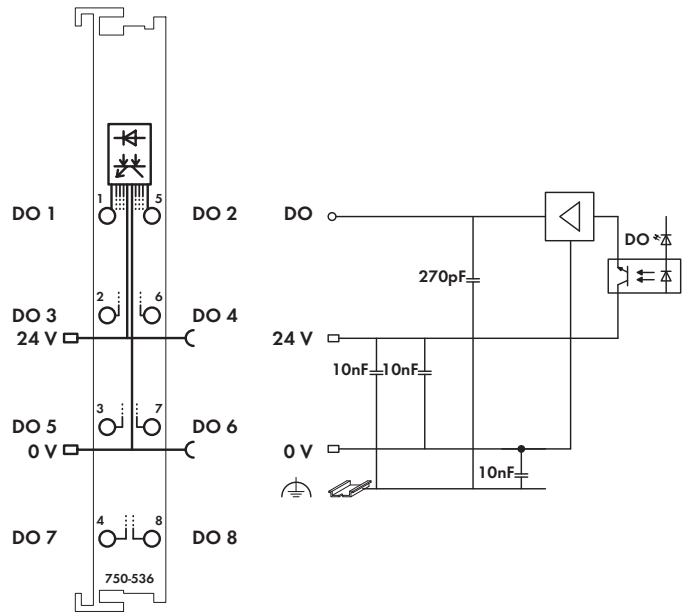

NOTE: Connection point marking (i.e., 1 ... 8) does not refer to channel assignment

The digital output module provides 8 channels at a width of just 12mm (0.47in.).
The connected load is switched via digital output from the control system.

All outputs are short-circuit proof.

Field and system levels are electrically isolated.

Description	Item No.	Pack. Unit
8DO 24V DC 0.5A	750-536	1
8DO 24V DC 0.5A (without connector)	753-536	1
Accessories		
753 Series Connectors	753-110	25
Coding elements	753-150	100
Miniature WSB Quick marking system		
plain	248-501	5
with marking	see Section 1.1	
Approvals		
Conformity marking	CE	
Korea Certification		
Marine applications	ABS, BV, DNV, GL, KR, LR, NKK, PRS, RINA	
UL 508		
ANSI/ISA 12.12.01	Class I, Div. 2, Grp. ABCD, T4	
TÜV 07 ATEX 554086 X	I M2 Ex d I Mb, II 3 G Ex nA IIC T4 Gc, II 3 D Ex tc IIIC T135°C Dc	
Permissible ambient temperature	0 °C ... +60 °C	
IECEX TUN 09.0001 X	Ex d I Mb, Ex nA IIC T4 Gc, Ex tc IIIC T135°C Dc	
Permissible ambient temperature	0 °C ... +60 °C	

Technical Data	
No. of outputs	8
Max. current consumption (internal)	25 mA
Voltage via power jumper contacts	24 V DC (-25 % ... +30 %)
Type of load	resistive, inductive, lamps
Max. switching frequency	2 kHz
Output current	0.5 A, short-circuit protected
Reverse voltage protection	yes
Inductive load switch off energy	
dissipation W (max.)	0.5 J; L max = 2 x W max / I ²
Current consumption typ. (field side)	12 mA / module + load
Isolation	500 V system/supply
Internal bit width	8 bit out
Wire connection	CAGE CLAMP®
Cross sections	0.08 mm ² ... 2.5 mm ² / AWG 28 ... 14
Strip lengths, 750/753 Series	8 ... 9 mm / 0.33 in 9 ... 10 mm / 0.37 in
Width	12 mm
Weight	49.6 g
EMC immunity of interference	acc. to EN 61000-6-2, marine applications
EMC emission of interference	acc. to EN 61000-6-3, marine applications