

2	3	4	5	6	7	8	9
标记 MARK	ECN编号/变更内容 ECN NO/DEFINITION	修改 REVISE	日期 DATE	核准 APPROVE			

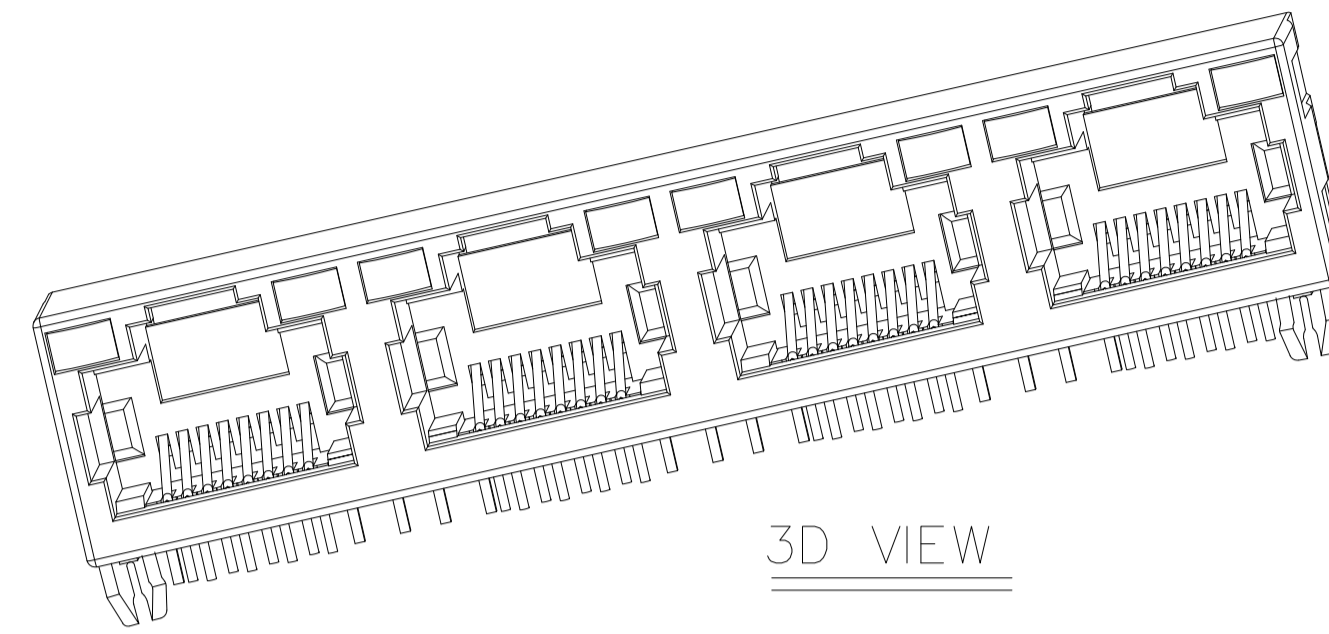

NOTES:

1. MATERIAL:
 - 1.1. HOUSING: PBT ,COLOR IS BLACK;
 - 1.2. CONTACT: PHOSPHOR BRONZE, $\phi 0.46 \pm 0.02\text{mm}$;
2. FINISH: PLATED GOLD OVER NI;
3. RECINNEBDED PCB THICKNESS: 1.60mm;
4. ELECTRICAL:
 - 4.1. VOLTAGE RATING: 125 VAC RMS;
 - 4.2. CURRENT RATING: 1.5 AMP;
 - 4.3. CONTACT RESISTANCE: 35MILLIOHMS MAX.;
 - 4.4. WITHSTAND VOLTAGE: 500 VAC RMS 50(60)Hz,1MIN.;
 - 4.5. INSULATION RESISTANCE: 500MEGOHMS MIN @500V DC;
5. MECHANICAL:
 - 5.1. MATING/UNMATING FORCE: 25N MAX.;
 - 5.2. RETENTION STRENGTH: 50N MIN.;
 - 5.3. OPERATING LIFE: 750 CYCLES MIN.;
6. SALT SPRAY TEST: 12H;
7. SOLDERABILITY: $245 \pm 5^\circ\text{C}, 5 \pm 0.5\text{S}$;
8. RESISTANCE TO SOLDER: $260 \pm 5^\circ\text{C}, 10 \pm 1\text{S}$;
- 9 ENVIRONMENTAL:
 - 9.1. STORAGE TEMPERATURE RANGE: $-40^\circ\text{C} \sim +85^\circ\text{C}$;
 - 9.2. OPERATION TEMPERATURE RANGE: $-25^\circ\text{C} \sim +70^\circ\text{C}$;
10. MATES WITH: MODULAR PLUGS THAT CONFORM TO FCC REGULATION PART 68.500;

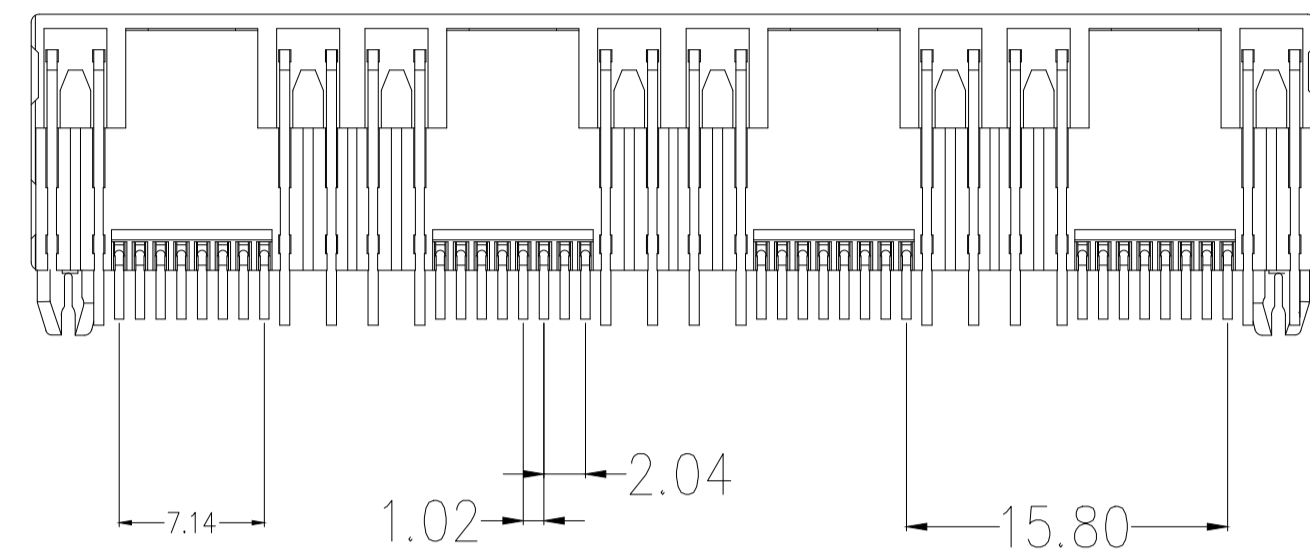
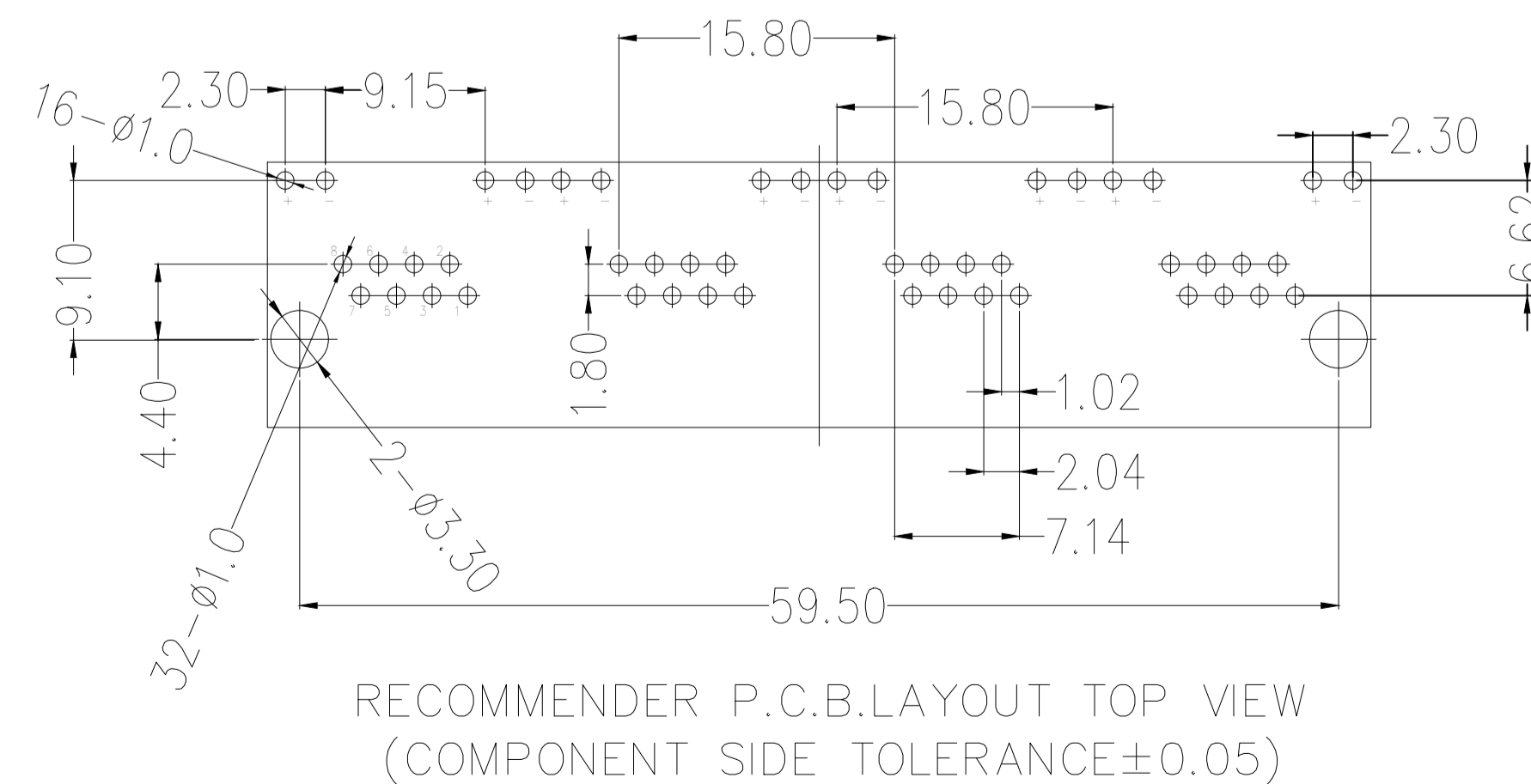
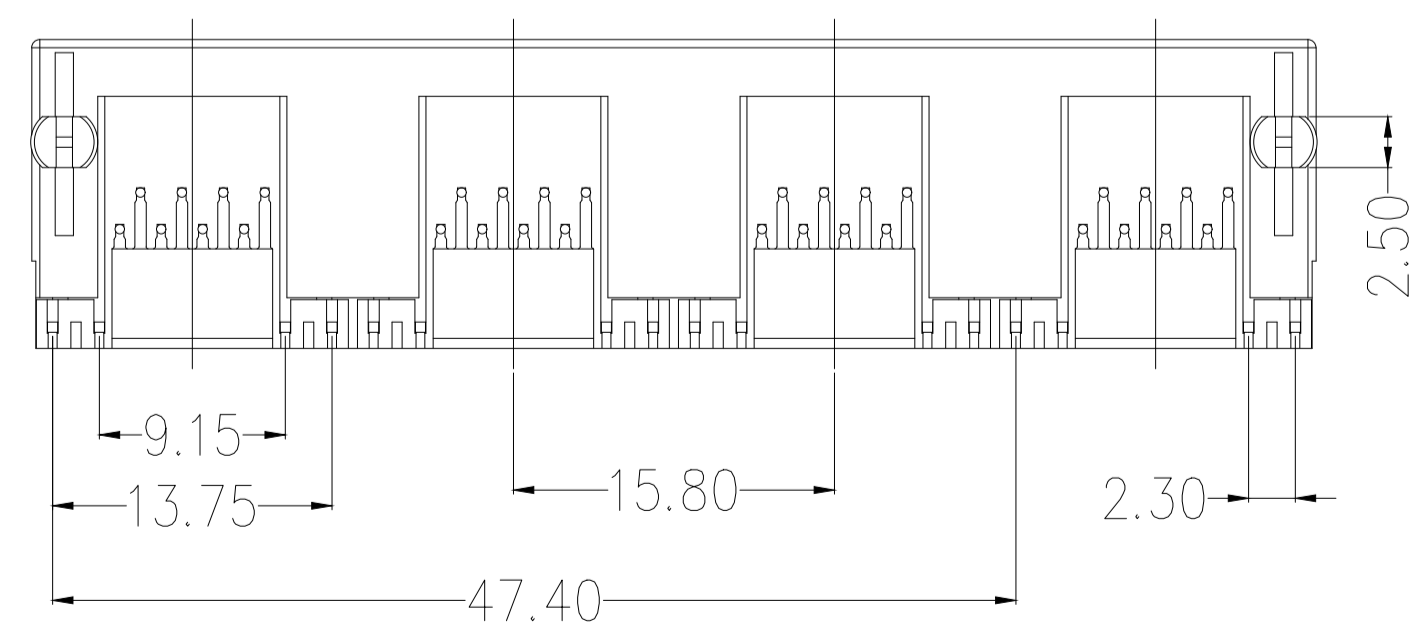
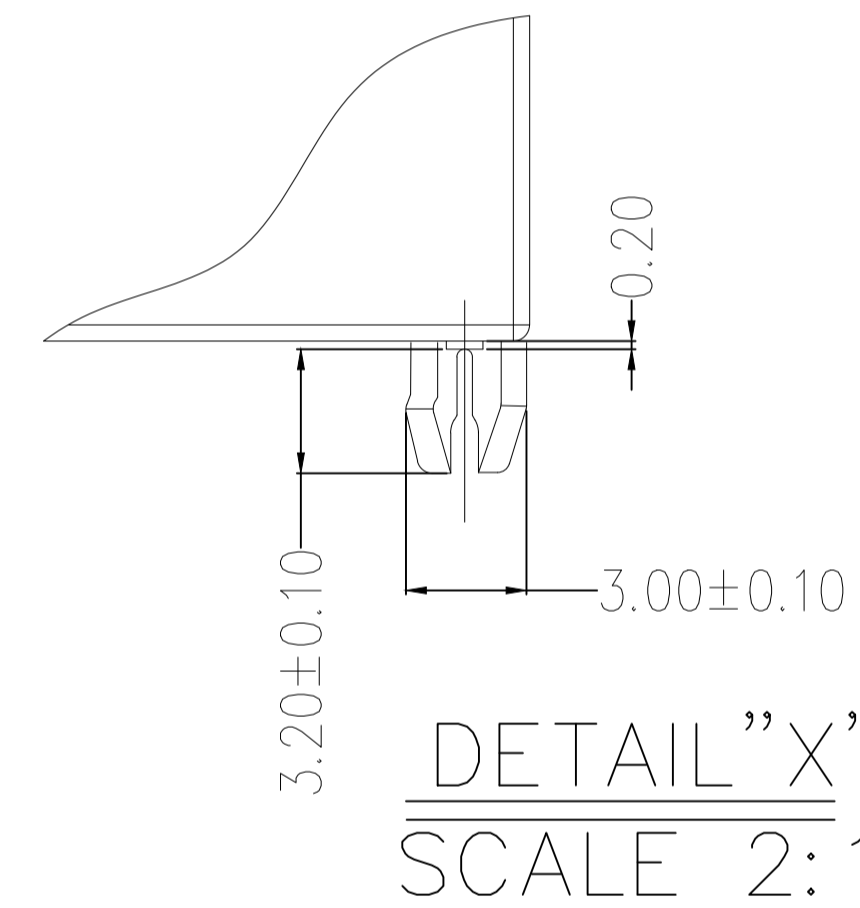
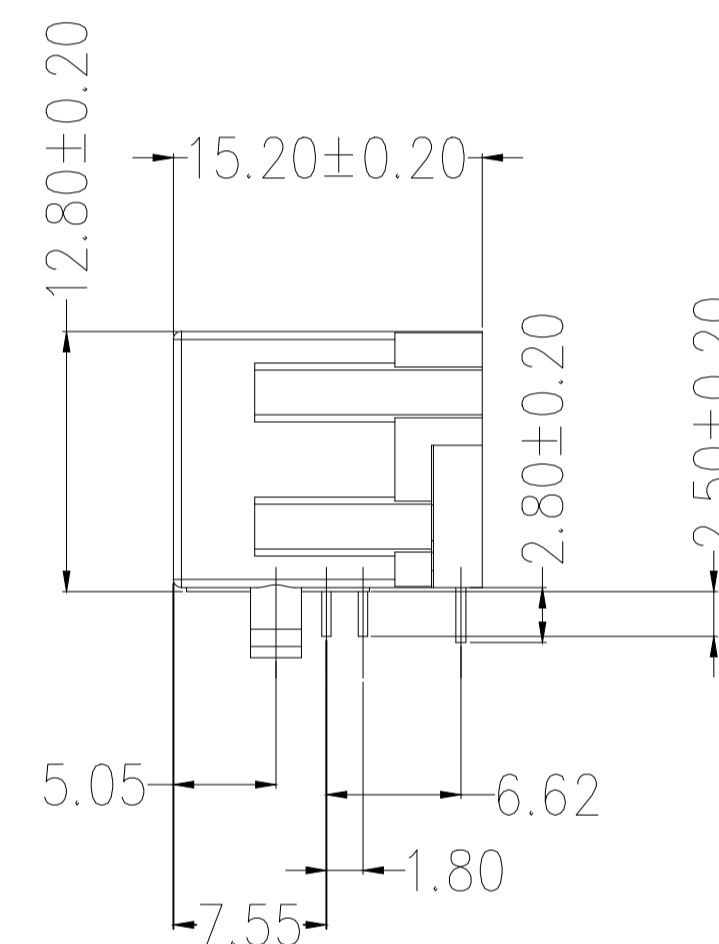
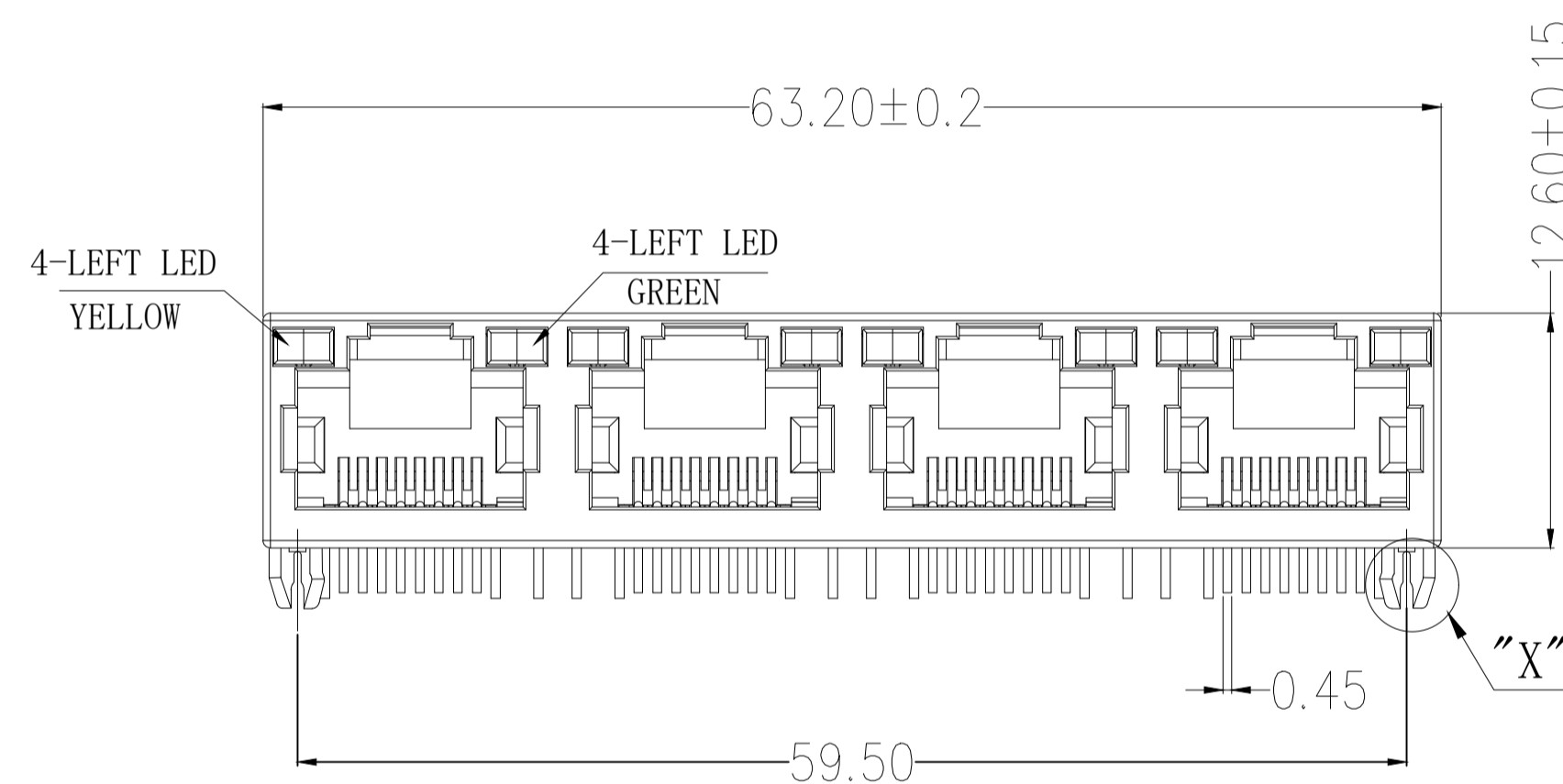

2	接触	铜	镀金G/F	
1	基座	PBT	黑色	
序号	品名	材质	电镀/颜色	备注

	深圳市虹成电子有限公司 品名 TITLE: 网口 料号 PART NO: HC-WK88-H16-1X4-QSD		
	比列 SCALE: 1:1 单位 UNIT: MM 张数 PART NO: 1 OF 1 版本 REV: A	制图 DRAW: AhYe 审核 CHECKED: 夏操云 批准 APPROVE: 赵亮亮	
UNLESS OTHERWISE, GENERAL TOLERANCE: X. xxx ±0.10 X. xx ±0.20 X. x ±0.30 ANGULAR: X. xx° ±1° X. x° ±3° X. ° ±5°			