

Analog Linear Displacement Sensor



DESIGN SUPPORT TOOLS

[click logo to get started](#)

3D
Models
Available

FEATURES

- Conductive plastic potentiometer technology. Infinite resolution
- Anodized light alloy housing
- Stainless steel floating shaft
- Flange mounting
- Wire outputs
- Material categorization: for definitions of compliance please see www.vishay.com/doc?99912



RoHS
COMPLIANT

QUICK REFERENCE DATA

Sensor type	LINEAR, conductive plastic
Output type	Output by wires
Market appliance	Industrial
Dimensions	Diameter 1/2" (12.7 mm)

ELECTRICAL SPECIFICATIONS

PARAMETER										
Theoretical electrical travel	UET +1 mm to 0 mm									
Independent linearity standard	± 0.5 %									
Independent linearity optional	± 0.1 % (UET ≥ 50 mm), ± 0.25 % (UET < 50 mm)									
Tolerance on R _n	± 20 %									
Temperature coefficient	-300 ± 300 ppm/°C									
Wiper current	≤ 1 mA									
Recommended load impedance	≥ 1000 R _n									
Dielectric strength	500 V _{RMS} , 50 Hz, 1 min									
Insulation resistance	≥ 10 GΩ at 500 V _{DC}									
Output smoothness	≤ 0.1 %									
Useful electrical travel (UET)	10 mm	25 mm	50 mm	75 mm	100 mm	150 mm	200 mm	250 mm	300 mm	
Power rating at +70 °C (0.2 W/cm of travel)	0.2 W	0.5 W	1.0 W	1.5 W	2.0 W	3.0 W	4.0 W	5.0 W	6.0 W	
Total resistance R _n	2.2 kΩ	4.7 kΩ	4.7 kΩ	10 kΩ	10 kΩ	10 kΩ	10 kΩ	22 kΩ	22 kΩ	

MECHANICAL SPECIFICATIONS

PARAMETER										
Mechanical travel	UET + 4 mm									
Driving force	≤ 2 N									
Backlash	< 15 μm									
Protection class	IP 64									
Maximum displacement speed	1.5 m/s									
Mounting	1 block (UET < 100 mm) and 2 blocks (UET ≥ 100 mm)									
Useful electrical travel (UET)	10 mm	25 mm	50 mm	75 mm	100 mm	150 mm	200 mm	250 mm	300 mm	
Weight	Shaft + wiper	4 g	6 g	8 g	11 g	13 g	18 g	23 g	28 g	33 g
	Sensor	20 g	22 g	27 g	30 g	40 g	51 g	65 g	75 g	86 g

PERFORMANCE

PARAMETER	
Operating temperature range	-40 °C to +105 °C
Storage temperature range	-55 °C to +125 °C
Life	20M cycles

Note

- Nothing stated herein shall be construed as a guarantee of quality or durability

SAP PART NUMBERING GUIDELINES							
MODEL	USEFUL ELECTRICAL TRAVEL (mm)	TYPE	VALUE	LINEARITY	LEADS	PACKAGING	
RP12	010	L = linear	222 = 2K2	B = 0.5 %	W = wire	b = bulk	
	025		472 = 4K7				
	050		103 = 10K				
	075		223 = 22K				
	100						
	150						
	200						
	250						
	300		In accordance with UET, see "Electrical Specifications"				

DIMENSIONS in millimeters

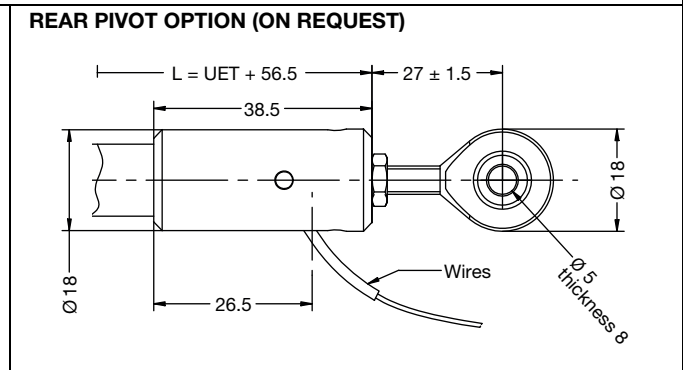
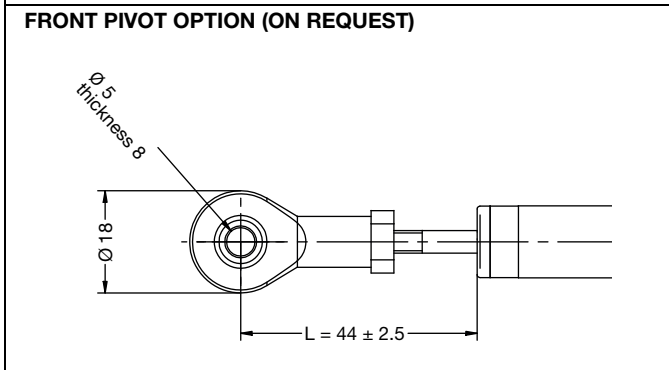
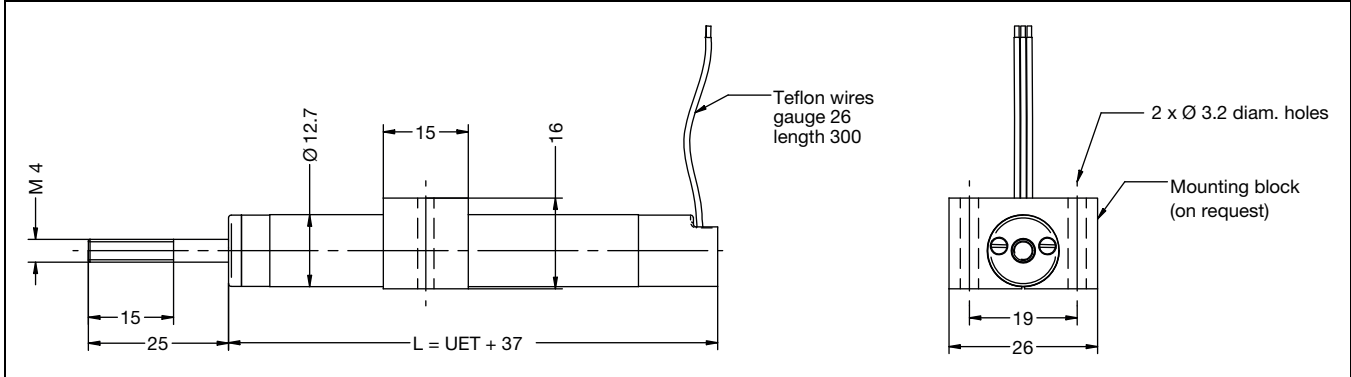

STRAIGHT OR RIGHT ANGLE CONNECTOR OPTION (ON REQUEST)

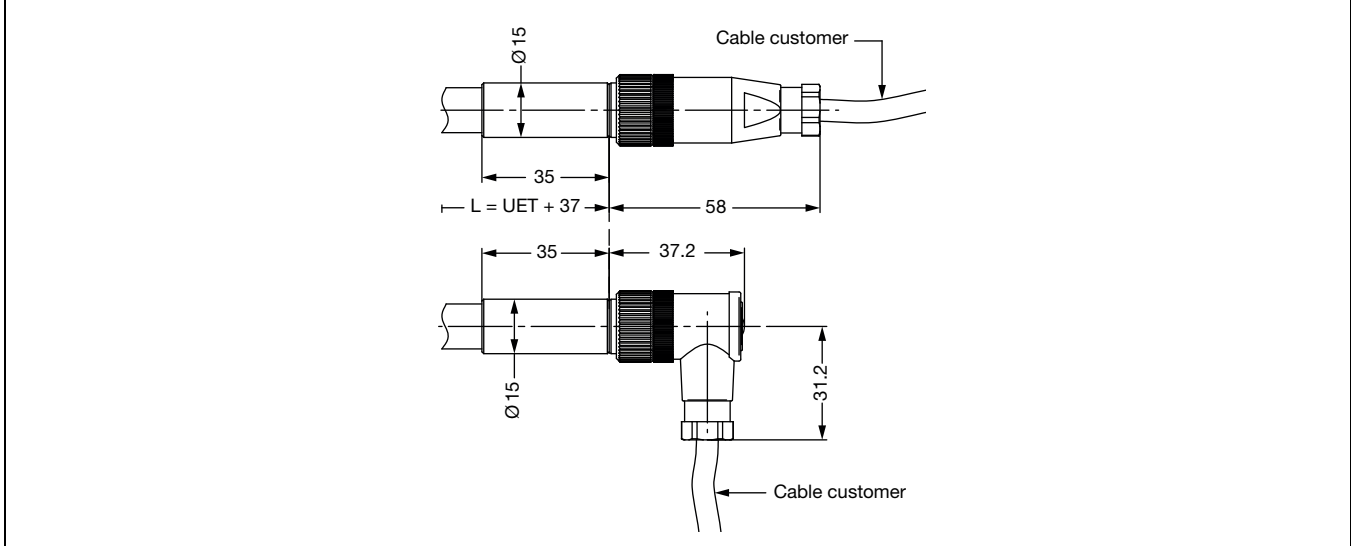

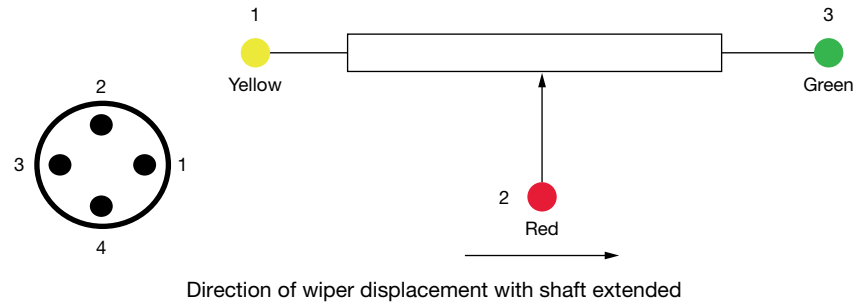
ELECTRICAL DIAGRAM

CONNECTION
OPTIONS (on request)

- Other linearity
- Probe version for UET < 100 mm (spring and tip)
- Low driving force version (≤ 30 cN/ IP 50)
- Lateral or axial cable output
- Binder 713-M12 series straight connector output
- Binder 713-M12 series right angle connector output
- Male socket fitted on connector
- Additional mounting block
- Front pivot
- Rear pivot (only with lateral cable output)



Disclaimer

ALL PRODUCT, PRODUCT SPECIFICATIONS AND DATA ARE SUBJECT TO CHANGE WITHOUT NOTICE TO IMPROVE RELIABILITY, FUNCTION OR DESIGN OR OTHERWISE.

Vishay Intertechnology, Inc., its affiliates, agents, and employees, and all persons acting on its or their behalf (collectively, "Vishay"), disclaim any and all liability for any errors, inaccuracies or incompleteness contained in any datasheet or in any other disclosure relating to any product.

Vishay makes no warranty, representation or guarantee regarding the suitability of the products for any particular purpose or the continuing production of any product. To the maximum extent permitted by applicable law, Vishay disclaims (i) any and all liability arising out of the application or use of any product, (ii) any and all liability, including without limitation special, consequential or incidental damages, and (iii) any and all implied warranties, including warranties of fitness for particular purpose, non-infringement and merchantability.

Statements regarding the suitability of products for certain types of applications are based on Vishay's knowledge of typical requirements that are often placed on Vishay products in generic applications. Such statements are not binding statements about the suitability of products for a particular application. It is the customer's responsibility to validate that a particular product with the properties described in the product specification is suitable for use in a particular application. Parameters provided in datasheets and / or specifications may vary in different applications and performance may vary over time. All operating parameters, including typical parameters, must be validated for each customer application by the customer's technical experts. Product specifications do not expand or otherwise modify Vishay's terms and conditions of purchase, including but not limited to the warranty expressed therein.

Except as expressly indicated in writing, Vishay products are not designed for use in medical, life-saving, or life-sustaining applications or for any other application in which the failure of the Vishay product could result in personal injury or death. Customers using or selling Vishay products not expressly indicated for use in such applications do so at their own risk. Please contact authorized Vishay personnel to obtain written terms and conditions regarding products designed for such applications.

No license, express or implied, by estoppel or otherwise, to any intellectual property rights is granted by this document or by any conduct of Vishay. Product names and markings noted herein may be trademarks of their respective owners.