

6A Dual-Channel Ultra-Low On-Resistance Load Switch with Slew Rate Control

Features

- Integrated dual-channel NMOS load switch
- Input voltage: $V_{IN}=0.6V$ to V_{BIAS}
- V_{BIAS} voltage: $V_{BIAS}=2.5V$ to $5.5V$
- On-resistance
 - $R_{on}=18.5m\Omega$ (Typical)
at $V_{BIAS}=5V$ and $V_{IN}=0.6V$ to $5V$
 - $R_{on}=19m\Omega$ (Typical)
at $V_{BIAS}=2.5V$ and $V_{IN}=0.6V$ to $2.5V$
- 6A continuous switch current
- Quiescent Current
 - $40\mu A$ (typical, both channels)
at $V_{BIAS}=5V$ and $V_{IN}=5V$
 - $20\mu A$ (typical, single channel)
at $V_{BIAS}=5V$ and $V_{IN}=5V$
- Controlled slew rate to limit inrush currents
- Over-Temperature Protection(OTP)
- Quick Output Discharge (QOD)
- DFN 3mmX2mmX0.75mm-14L Package with Thermal Pad

General Description

The AW35142 is a dual-channel NMOS load switch with slew rate control. The device integrated a typical R_{on} of $18.5m\Omega$ and has 6A maximum continuous switch current. Each channel has independent enable control pin ON1/ON2 which is suitable for interfacing directly with low voltage I/O ports.

The AW35142 features over temperature protection. The device shuts down when the junction temperature exceeds $160^{\circ}C$ and return on when the temperature drops $30^{\circ}C$. The AW35142 also has QOD function which can prevent the output from floating when the switch is disabled.

Applications

Notebook

Tablet PCs

Consumer Electronics

Typical Application Circuit

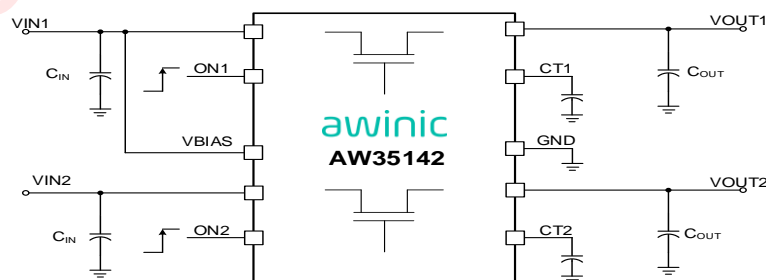

Figure 1 Typical Application Circuit of AW35142DNR

Pin Configuration And Top Mark

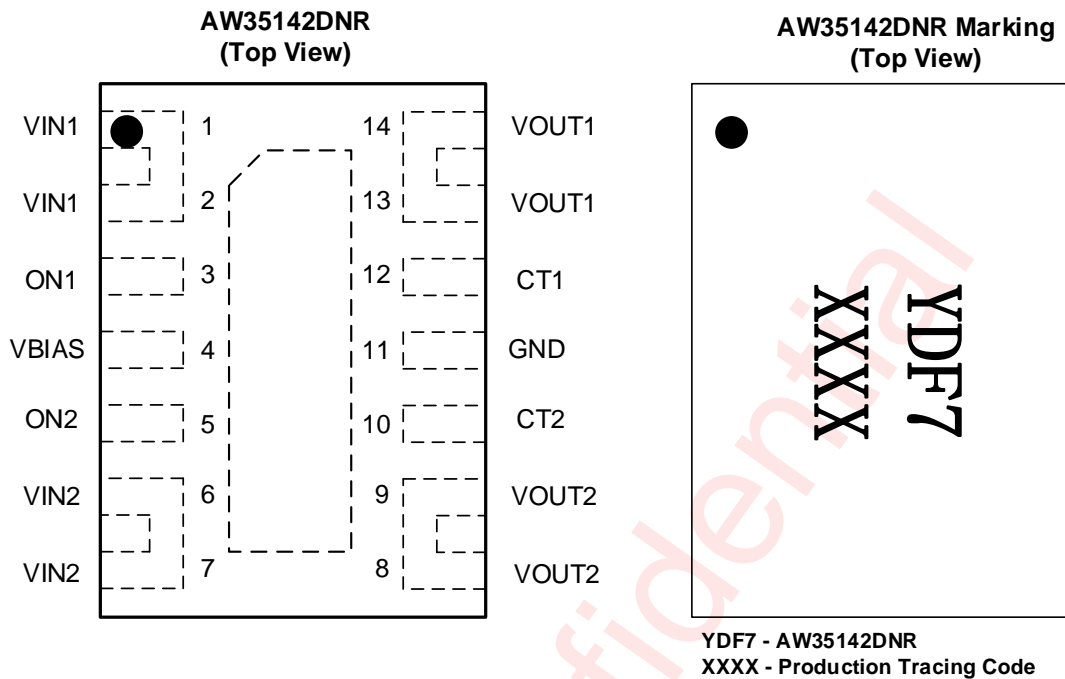

Figure 2 Pin Configuration and Top Mark

Pin Definition

Pin	Name	Description
1	VIN1	Channel 1 input
2		
3	ON1	Channel 1 enable (active high)
4	VBIAS	Power supply
5	ON2	Channel 2 enable (active high)
6	VIN2	Channel 2 input
7		
8	VOUT2	Channel 2 output
9		
10	CT2	Channel 2 slew rate control
11	GND	Ground
12	CT1	Channel 1 slew rate control
13	VOUT1	Channel 1 output
14		

Functional Block Diagram

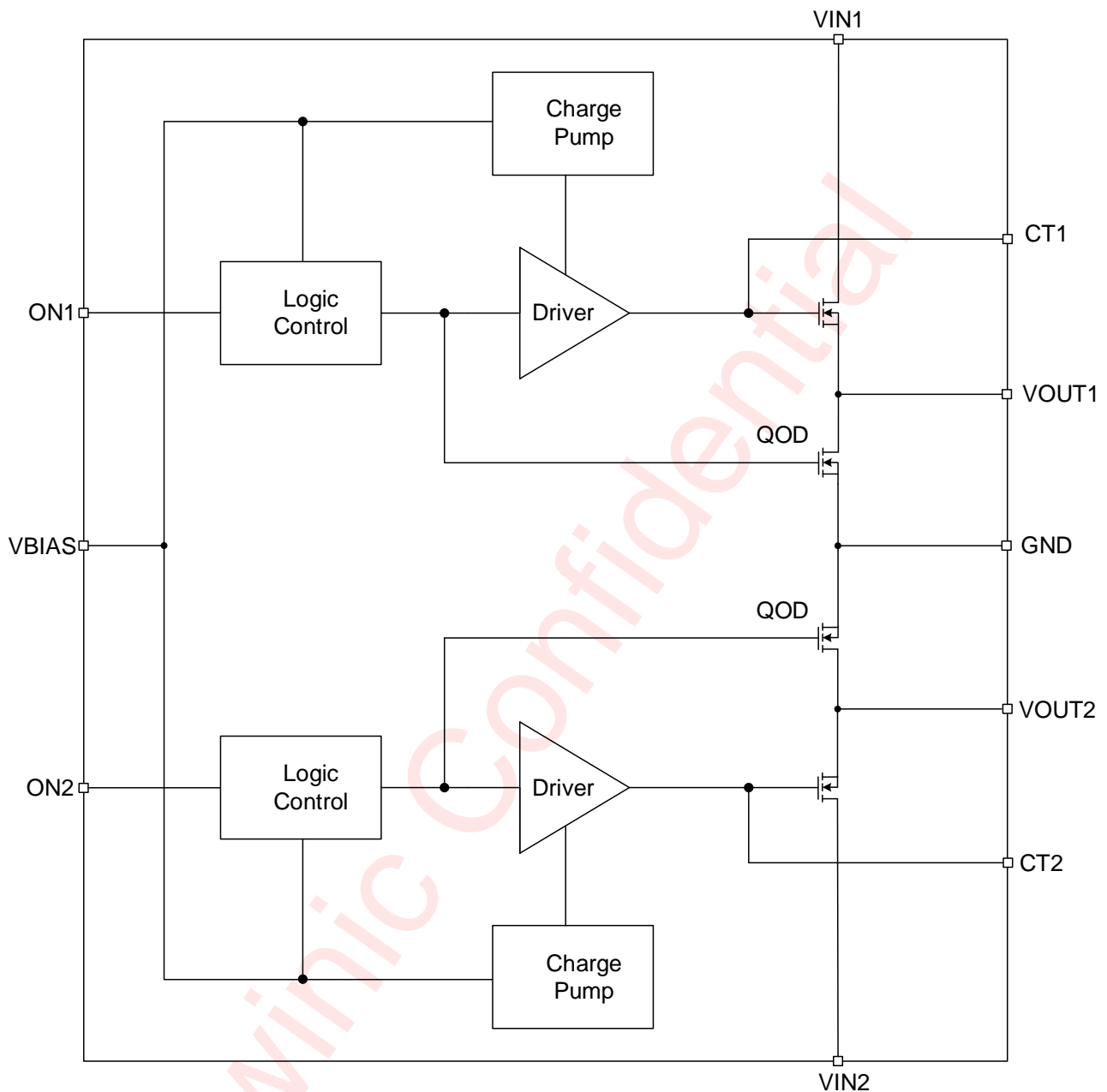

Figure 3 Functional Block Diagram

Ordering Information

Part Number	Temperature	Package	Marking	Moisture Sensitivity Level	Environmental Information	Delivery Form
AW35142DNR	-40°C ~ 105°C	DFN3mmX2mmX0.75mm-14L	YDF7	MSL1	ROHS+HF	3000 units/ Tape and Reel

Absolute Maximum Ratings^(NOTE1)

PARAMETERS	RANGE
Input voltage range V_{IN}	-0.3V to 6V
BIAS voltage range V_{BIAS}	-0.3V to 6V
Enable control voltage range	-0.3V to 6V
Output voltage range	-0.3V to 6V
Junction-to-ambient thermal resistance θ_{JA} ^(NOTE2)	60°C/W
Operating free-air temperature range	-40°C to 105°C
Maximum operating junction temperature T_{JMAX}	150°C
Storage temperature T_{STG}	-65°C to 150°C
Lead temperature (soldering 10 seconds)	260°C
ESD	
HBM (Human body model) ^(NOTE3)	±2kV
CDM (Charged device model) ^(NOTE4)	±1kV
Latch-Up	
Latch-Up ^(NOTE5)	+IT: 200mA -IT: -200mA

NOTE1: Conditions out of those ranges listed in "absolute maximum ratings" may cause permanent damages to the device. In spite of the limits above, functional operation conditions of the device should be within the ranges listed in "recommended operating conditions". Exposure to absolute-maximum-rated conditions for prolonged periods may affect device reliability.

NOTE2: Thermal resistance from junction to ambient is highly dependent on PCB layout.

NOTE3: The human body model is a 100pF capacitor discharged through a 1.5kΩ resistor into each pin. Test method: ESDA/JEDEC JS-001-2017.

NOTE4: All pins. Test Condition: ESDA/JEDEC JS-002-2018.

NOTE5: Test Condition: JESD78E.

Recommended Operating Conditions

Symbol	Parameter	Min.	Typ.	Max.	Unit
V_{IN1} V_{IN2}	Input voltage	0.6		V_{BIAS}	V
V_{ON1} V_{ON2}	EN voltage	0		V_{BIAS}	V
V_{OUT1} V_{OUT2}	Output voltage	0		V_{IN}	V
V_{BIAS}	Power supply	2.5		5.5	V
C_{T1} C_{T2}	Slew rate control	0	1000		pF
C_{IN}	Input capacitance	1			μF
C_{OUT}	Output capacitance		0.1		μF

Electrical Characteristics— $V_{BIAS}=5V$

Unless noted otherwise, V_{BIAS} voltage range of 2.5 V to 5.5 V, operating temperature range of $-40^{\circ}C$ to $+105^{\circ}C$. Typical values are guaranteed for $V_{BIAS}=V_{IN}=V_{ON}=5V$, $T_A = 25^{\circ}C$.

PARAMETER		TEST CONDITION	MIN	TYP	MAX	UNIT
$I_{Q, VBIAS}$	V_{BIAS} quiescent current for both channels	$V_{IN1,2}=5V$, $V_{ON1,2}=5V$, no load		40		μA
	V_{BIAS} quiescent current for single channel	$V_{IN1}=5V$, $V_{ON1}=5V$, $V_{ON2}=0V$ no load		20		μA
$I_{SD, VBIAS}$	V_{BIAS} shutdown current for both channels	$V_{ON1,2}=0V$, $V_{OUT1,2}=0V$		70		nA
$I_{SD, VIN}$	V_{IN} shutdown current for each channel	$V_{ON}=0V$, $V_{OUT}=0V$	$V_{IN}=5V$	30		nA
			$V_{IN}=3.3V$	15		nA
			$V_{IN}=1.8V$	8		nA
			$V_{IN}=0.6V$	3		nA
I_{ON}	ON pin leakage current for each channel	$V_{ON}=5V$		1		nA
R_{on}	On-resistance	$I_{OUT}=-200mA$, $V_{IN}=0.6$ to $5V$		18.5		m Ω
R_{DISC}	Output discharge resistance	$V_{IN}=V_{OUT}=5V$, $V_{ON}=0V$		220		Ω
V_{IH}	ON input high threshold level		1.2			V
V_{IL}	ON input low threshold level				0.4	V
T_{SD}	Over temperature threshold	Junction Temperature Rising		160		$^{\circ}C$
$T_{SD, HYS}$	Over temperature hysteresis	Junction Temperature Falling		30		$^{\circ}C$

Electrical Characteristics— $V_{BIAS}=2.5V$

Unless noted otherwise, V_{BIAS} voltage range of 2.5 V to 5.5 V, operating temperature range of $-40^{\circ}C$ to $+105^{\circ}C$. Typical values are guaranteed for $V_{BIAS}=V_{IN}=V_{ON}=2.5V$, $T_A = 25^{\circ}C$.

PARAMETER		TEST CONDITION		MIN	TYP	MAX	UNIT
$I_{Q, VBIAS}$	V_{BIAS} quiescent current for both channels	$V_{IN1,2}=2.5V$, $V_{ON1,2}=2.5V$, no load			32		μA
	V_{BIAS} quiescent current for single channel	$V_{IN1}=2.5V$, $V_{ON1}=2.5V$, $V_{ON2}=0V$ no load			16		μA
$I_{SD, VBIAS}$	V_{BIAS} shutdown current for both channels	$V_{ON1,2}=0V$, $V_{OUT1,2}=0V$			20		nA
$I_{SD, VIN}$	V_{IN} shutdown current for each channel	$V_{ON}=0V$, $V_{OUT}=0V$	$V_{IN}=2.5V$		10		nA
			$V_{IN}=1.8V$		8		nA
			$V_{IN}=1.2V$		4		nA
			$V_{IN}=0.6V$		2		nA
I_{ON}	ON pin leakage current for each channel	$V_{ON}=2.5V$			1		nA
R_{on}	On-resistance	$I_{OUT}=-200mA$, $V_{IN}=2.5V$			19		m Ω
R_{DISC}	Output Discharge Resistance	$V_{IN}=V_{OUT}=2.5V$, $V_{ON}=0V$			250		Ω
V_{IH}	ON input high threshold level			1.2			V
V_{IL}	ON input low threshold level					0.4	V
T_{SD}	Over temperature threshold	Junction Temperature Rising			160		$^{\circ}C$
$T_{SD, HYS}$	Over temperature hysteresis	Junction Temperature Falling			30		$^{\circ}C$

Switching Characteristics

Unless noted otherwise, V_{BIAS} voltage range of 2.5 V to 5.5 V, operating temperature range of -40°C to $+105^{\circ}\text{C}$. Typical values are guaranteed for $V_{BIAS}=V_{IN}=V_{ON}=5\text{V}$, $T_A = 25^{\circ}\text{C}$.

PARAMETER		TEST CONDITION	MIN	TYP	MAX	UNIT
$V_{IN}=5\text{V}$, $V_{BIAS}=5\text{V}$						
t_D	ON Delay time	$R_L=10\Omega$, $C_L=0.1\mu\text{F}$, $C_T=1\text{nF}$		500		μs
t_{ON}	Turn-on time			1400		μs
t_R	Rising time			1500		μs
t_{OFF}	Turn-off time			4		μs
t_F	Falling time			2		μs
$V_{IN}=0.6\text{V}$, $V_{BIAS}=5\text{V}$						
t_D	ON Delay time	$R_L=10\Omega$, $C_L=0.1\mu\text{F}$, $C_T=1\text{nF}$		400		μs
t_{ON}	Turn-on time			500		μs
t_R	Rising time			400		μs
t_{OFF}	Turn-off time			6		μs
t_F	Falling time			2		μs
$V_{IN}=2.5\text{V}$, $V_{BIAS}=2.5\text{V}$						
t_D	ON Delay time	$R_L=10\Omega$, $C_L=0.1\mu\text{F}$, $C_T=1\text{nF}$		700		μs
t_{ON}	Turn-on time			1500		μs
t_R	Rising time			1600		μs
t_{OFF}	Turn-off time			7		μs
t_F	Falling time			2		μs
$V_{IN}=0.6\text{V}$, $V_{BIAS}=2.5\text{V}$						
t_D	ON Delay time	$R_L=10\Omega$, $C_L=0.1\mu\text{F}$, $C_T=1\text{nF}$		550		μs
t_{ON}	Turn-on time			800		μs
t_R	Rising time			500		μs
t_{OFF}	Turn-off time			9		μs
t_F	Falling time			2		μs

Timing Diagram

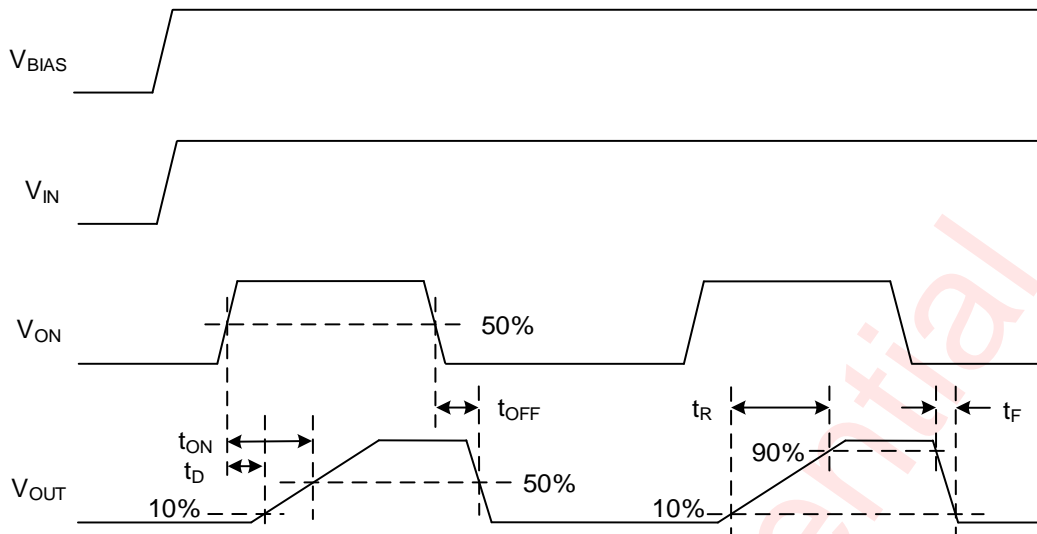

Figure 4 AW35142 Timing Diagram

Typical Characteristics

Ambient temperature is 25°C, $C_{IN} = 1\mu F$, $C_{OUT} = 0.1\mu F$, $C_T = 1nF$, unless otherwise noted.

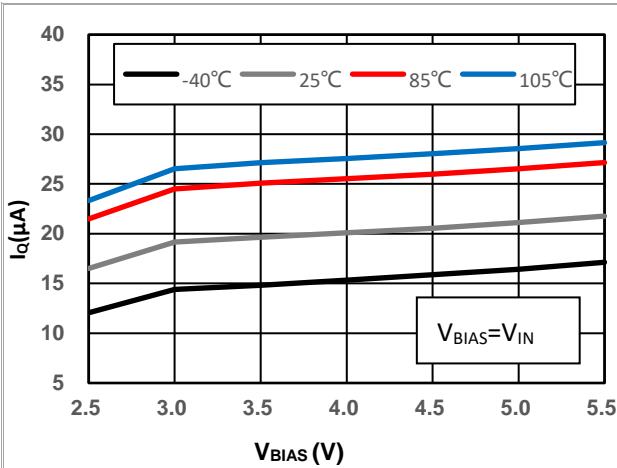

Figure 5 Quiescent Current vs. VBIAS, Single Channel

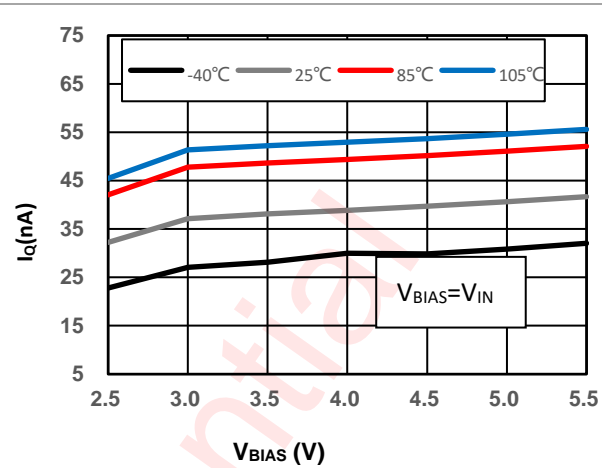

Figure 6 Quiescent Current vs. VBIAS, Both Channels

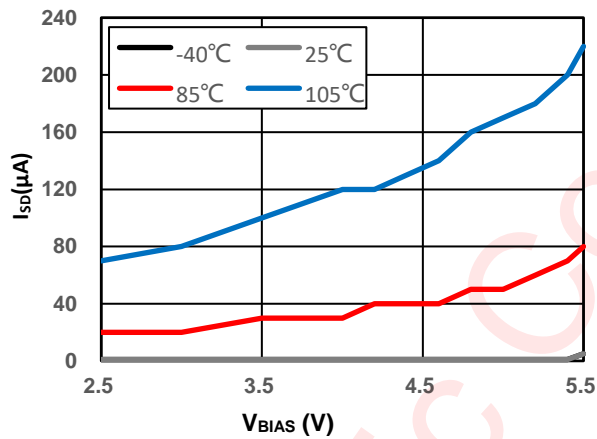

Figure 7 VBIAS Shutdown Current vs. VBIAS, Both Channels

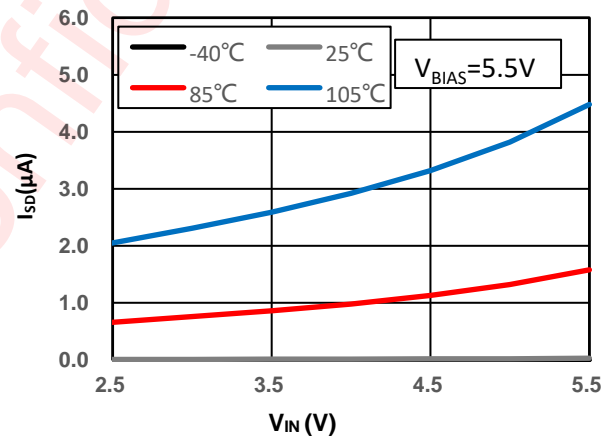

Figure 8 VIN Shutdown Current vs. VIN

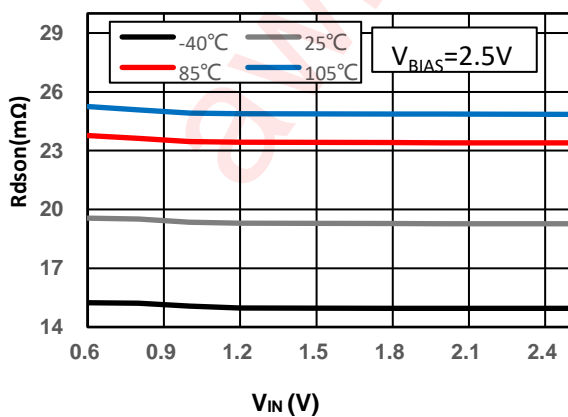

Figure 9 Rdson vs. VIN

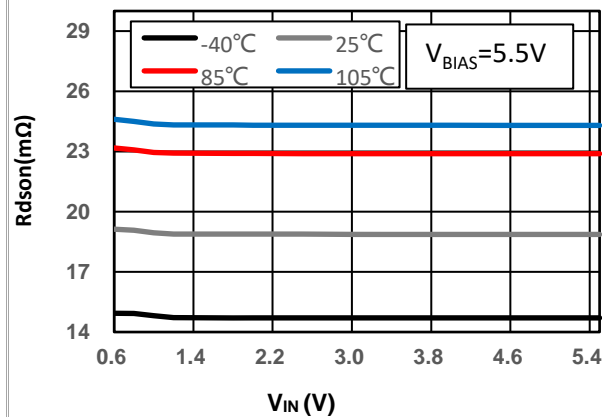

Figure 10 Rdson vs. VIN

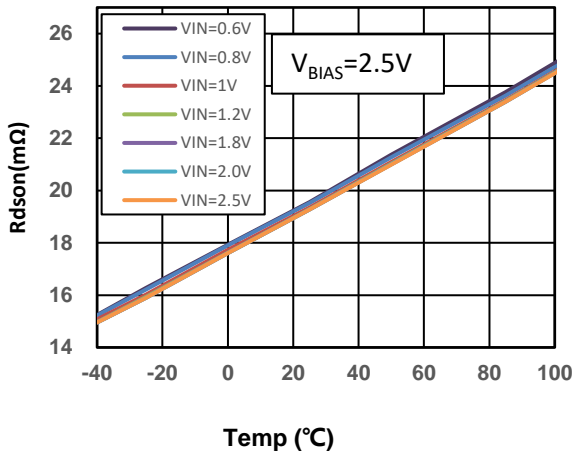

Figure 11 Rdson vs. Temp ($I_{OUT}=200mA$)

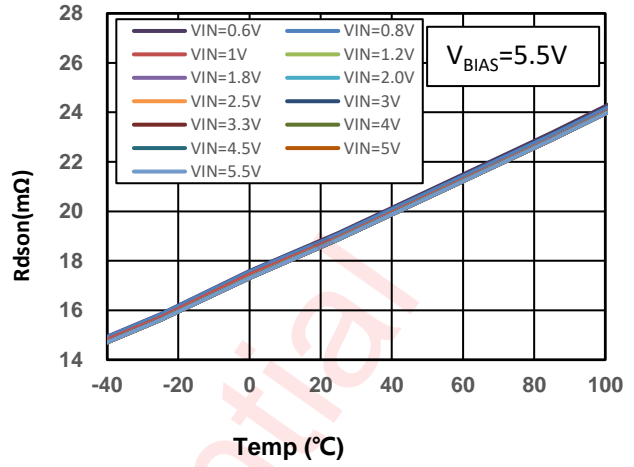

Figure 12 Rdson vs. Temp ($I_{OUT}=200mA$)

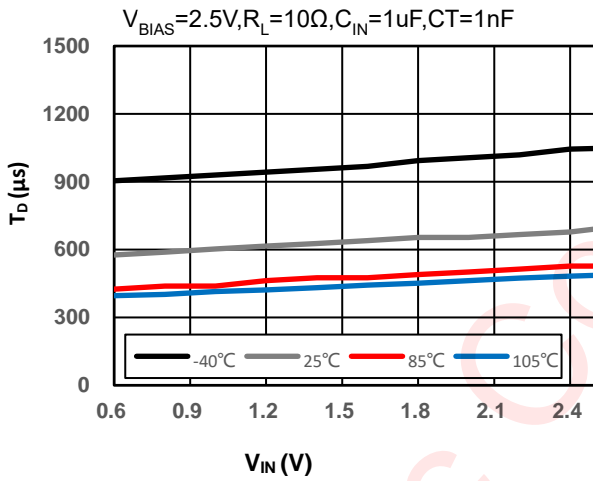

Figure 13 Turn On Delay vs. V_{IN}

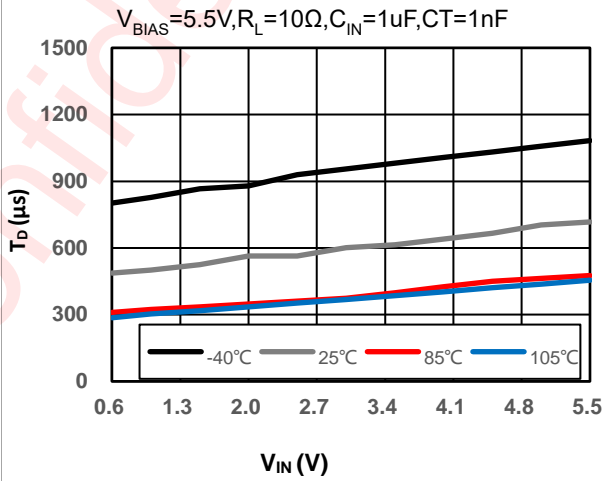

Figure 14 Turn On Delay vs. V_{IN}

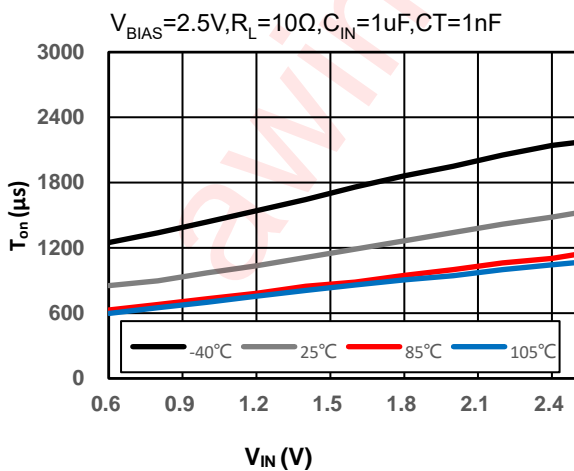

Figure 15 Turn On vs. V_{IN}

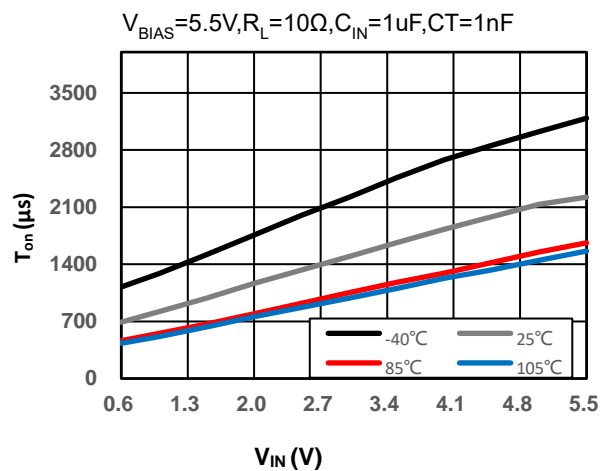

Figure 16 Turn On vs. V_{IN}

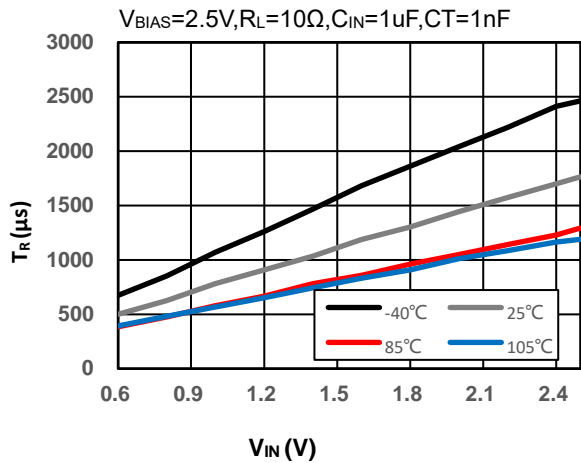

Figure 17 Rise Time vs. V_{IN}

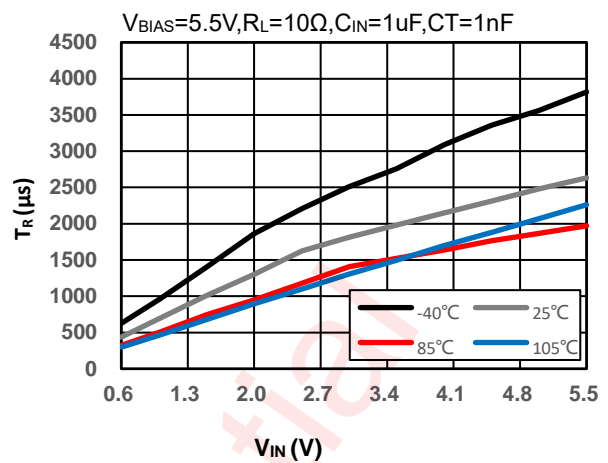

Figure 18 Rise Time vs. V_{IN}

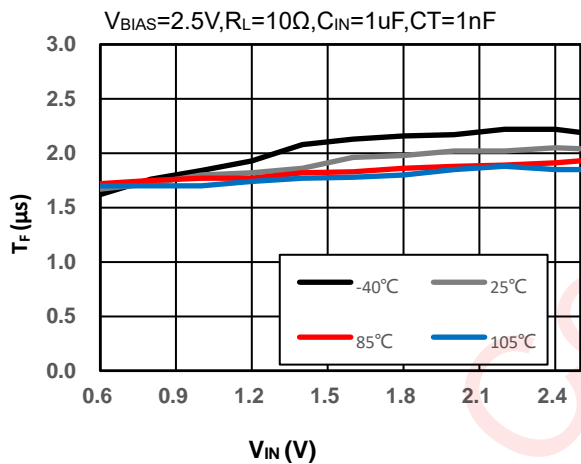

Figure 19 Fall Time vs. V_{IN}

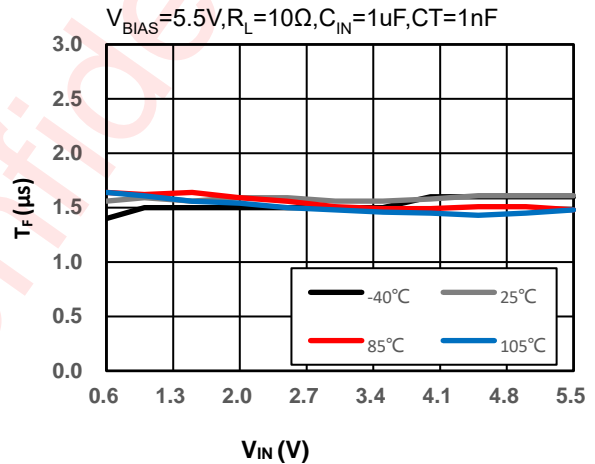

Figure 20 Fall Time vs. V_{IN}

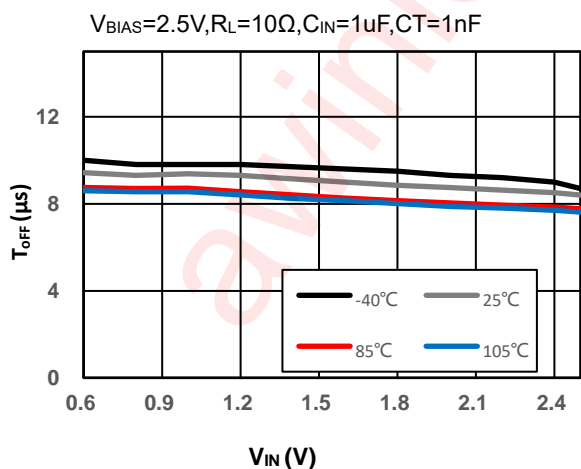

Figure 21 Turn Off vs. V_{IN}

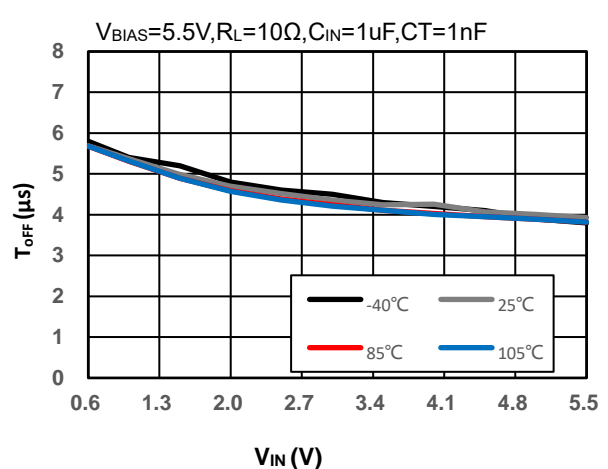
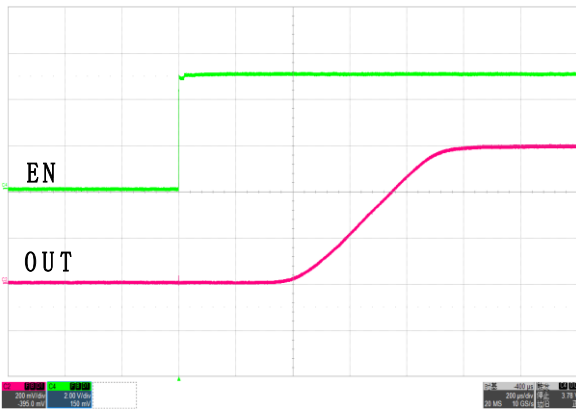
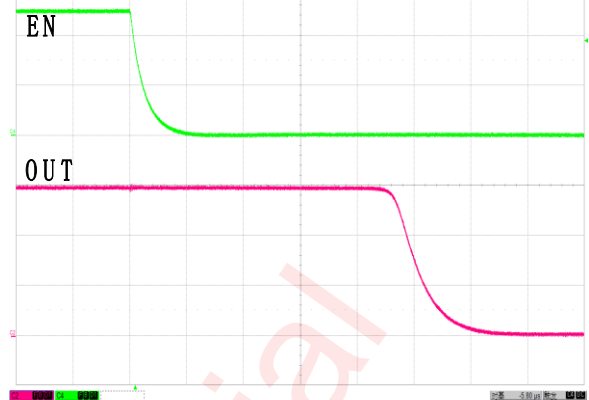

Figure 22 Turn Off vs. V_{IN}



$V_{BIAS}=2.5V, V_{IN}=0.6V, C_L=0.1\mu F, C_T=1nF, R_L=10\Omega$

Figure 23 Turn On Response



$V_{BIAS}=2.5V, V_{IN}=0.6V, C_L=0.1\mu F, C_T=1nF, R_L=10\Omega$

Figure 24 Turn Off Response

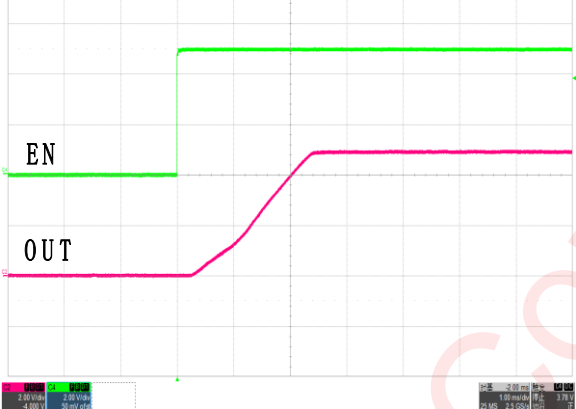

$V_{BIAS}=V_{IN}=5V, C_L=0.1\mu F, C_T=1nF, R_L=10\Omega$

Figure 25 Turn On Response



$V_{BIAS}=V_{IN}=5V, C_L=0.1\mu F, C_T=1nF, R_L=10\Omega$

Figure 26 Turn Off Response

Detailed Functional Description

The AW35142 is a both channels, 18.5 mΩ Ron (typical) N-type MOSFET load switch which can reduce the voltage drop in high current rails, the device can support 6A continuous current and controlled by the ON pin. In order to control the inrush current, the device has a configurable slew rate time for different applications by the CT pin.

Turn On/Off Control

The switch on/off controlled by ON pin which compatible standard GPIO logic. The device is enable or disable when the ON pin voltage higher than VIH or lower than VIL. Floating the ON pin is forbidden, it must be tied high or low.

Table 1. Functional Table

EN	IN to OUT	OUT to GND
Low	OFF	ON
High	ON	OFF

Slew Rate Control

The AW35142 provides an adjustable soft start time which can limit the inrush current when the switch is on. The slew rate time is controlled by the CT capacitor. This feature reduces the interference to the power supply.

Quick Output Discharge (QOD)

The AW35142 includes the Quick Output Discharge (QOD) feature, in order to discharge the application capacitor connected on OUT pin. When ON pin is set to low level (disable state), a discharge resistance with a typical value of 220Ω is connected between the output and ground, pull down the output and prevent it from floating when the device is disabled.

Over Temperature Protection (OTP)

When the junction temperature exceeds 160°C, the internal OTP circuit turn off the load switch. There is a temperature hysteresis 30°C, in other words, the OTP circuit can turn on the switch only if the junction temperature is below 130°C.

Adjustable Rise Time

The output rise time can be set by the capacitor between CT pin and GND. The slew rate can be calculated by the below formula approximately.

Equation (1) accounts for 10% to 90% measurement on V_{OUT} and does not apply for CT < 100pF, Use Table 2 to determine rise times for when CT=0pF.

$$SR=0.63 \times CT + 128$$

Where

- SR is the slew rate (in μs/V)
- CT is the capacitance value on the CT pin (in pF)
- The units for the constant 128 is in μs/V. (1)

Rise times shown below are only valid for the power-up sequence where V_{IN} and V_{BIAS} are already in steady condition.

Table 2. Rise time vs. CT

Rise time(μ s), $V_{OUT}(10\% \sim 90\%)$, $C_{IN}=1\mu F$, $C_{OUT}=0.1\mu F$, $V_{BIAS}=5V$, $R_L=10\Omega$							
CT/pF	Vin=5V	Vin=3.3V	Vin=1.8V	Vin=1.5V	Vin=1.2V	Vin=1.05V	Vin=0.6V
0	266	228	189	176	161	149	103
220	795	613	443	400	353	317	203
470	1345	1024	712	636	555	501	313
1000	2415	1813	1240	1096	949	849	521
2200	5148	3852	2581	2279	1966	1765	1064
4700	10747	8112	5432	4779	4128	3670	2202
10000	20865	15799	10570	9347	8013	7199	4332

PCB Layout Consideration

AW35142 is a low ON-Resistance load switch, to obtain the optimal performance, PCB layout should be considered carefully. Here are some guidelines:

1. All the peripherals should be placed as close to the device as possible. Place the capacitor C_{IN} , C_{BIAS} and C_T on the top layer (same layer as the AW35142) and close to IN, OUT and CT pin, and place the output capacitor C_{OUT} on the top layer (same layer as the AW35142) and close to OUT pin.
2. The AW35142 integrates an up to 6A NMOS FET, and the PCB design rules must be respected to properly evacuate the heat out of the silicon. By increasing PCB area, especially around IN and OUT pins, the $R_{\theta JA}$ of the package can be decreased, allowing higher power dissipation. Power lines will flow large current, please route them on PCB as straight, wide and short as possible, as in figure 27.
3. Use rounded corners on the power trace from the power supply connector to AW35142 to decrease EMI coupling.

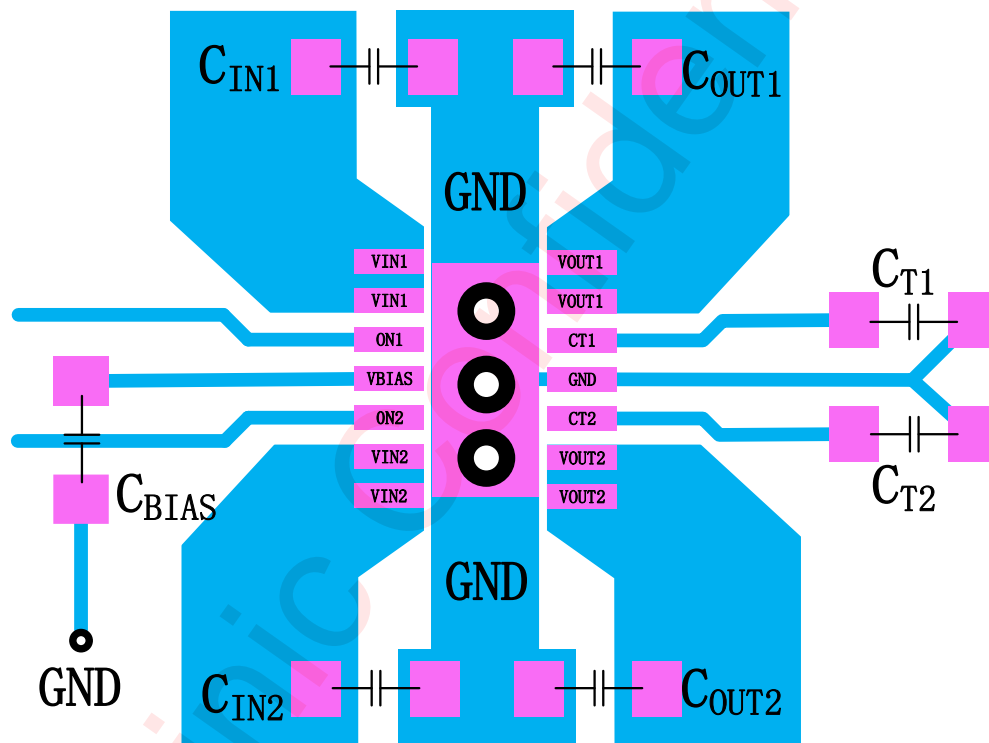
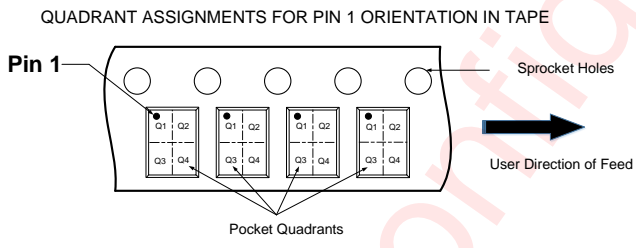
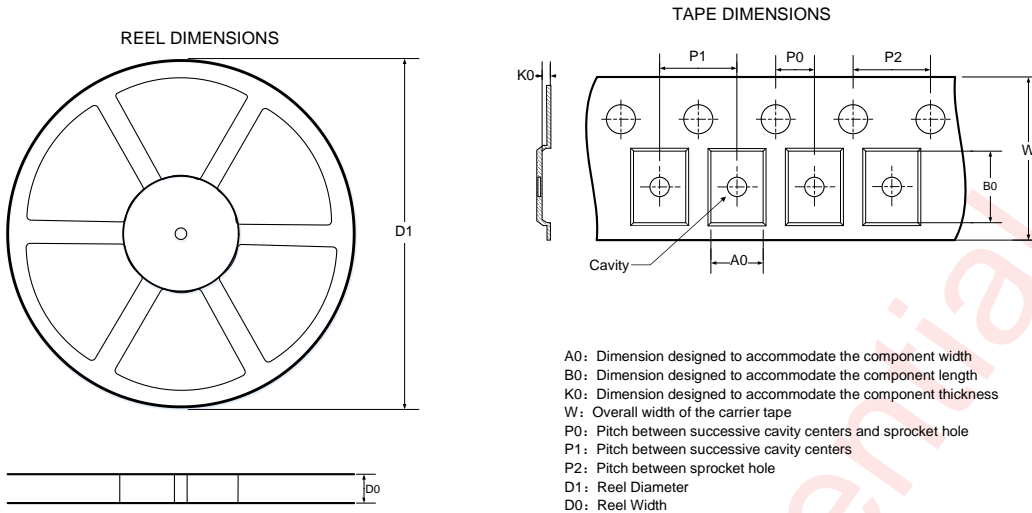

Figure 27 PCB layout example

Tape And Reel Information



DIMENSIONS AND PIN1 ORIENTATION

D1 (mm)	D0 (mm)	A0 (mm)	B0 (mm)	K0 (mm)	P0 (mm)	P1 (mm)	P2 (mm)	W (mm)	Pin1 Quadrant
178	8.4	2.3	3.2	1	2	4	4	8	Q1

All dimensions are nominal

Land Pattern Data

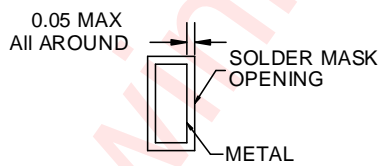
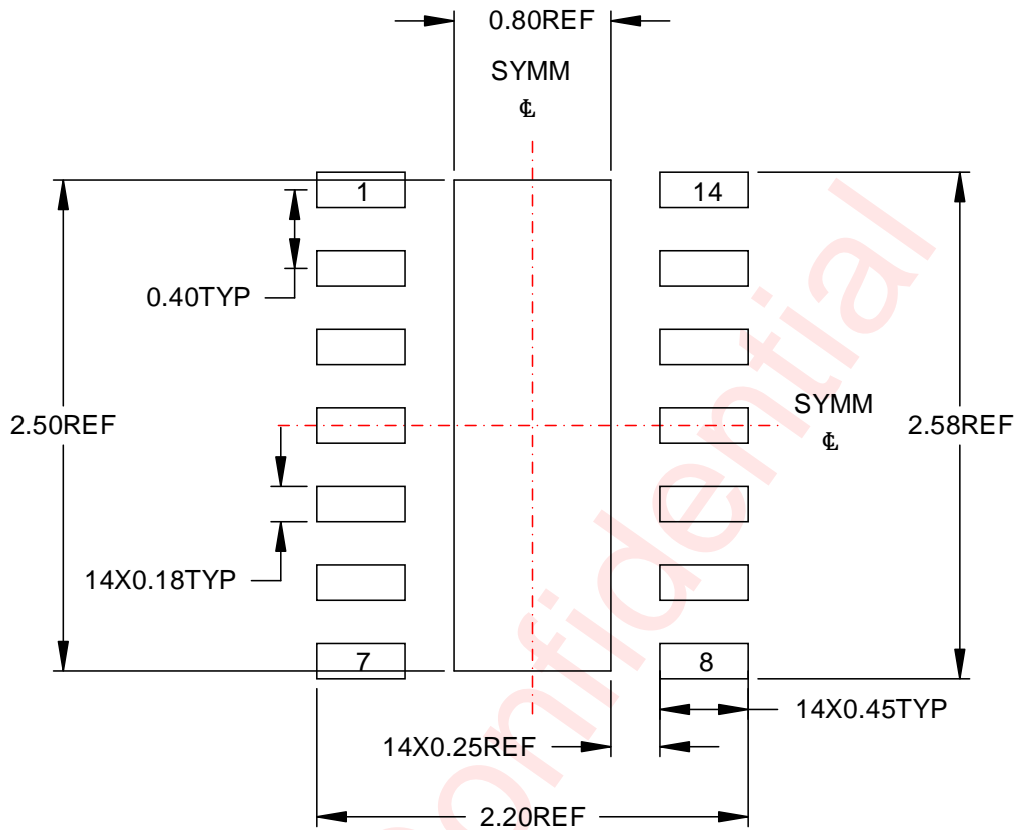

NON SOLDER MASK DEFINED

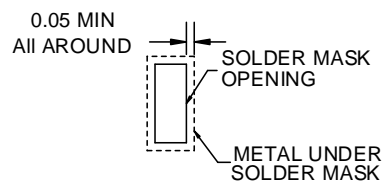

SOLDER MASK DEFINED

Unit: mm

Revision History

Version	Date	Change Record
V1.0	May 2021	Datasheet V1.0 Released
V1.1	Mar 2022	temperature range update: -40°C ~85°C to -40°C ~105°C
V1.2	Apr. 2023	Add Adjustable Rise Time section.(P13~P14)

awinic Confidential

Disclaimer

All trademarks are the property of their respective owners. Information in this document is believed to be accurate and reliable. However, Shanghai AWINIC Technology Co., Ltd (AWINIC Technology) does not give any representations or warranties, expressed or implied, as to the accuracy or completeness of such information and shall have no liability for the consequences of use of such information.

AWINIC Technology reserves the right to make changes to information published in this document, including without limitation specifications and product descriptions, at any time and without notice. Customers shall obtain the latest relevant information before placing orders and shall verify that such information is current and complete. This document supersedes and replaces all information supplied prior to the publication hereof.

AWINIC Technology products are not designed, authorized or warranted to be suitable for use in medical, military, aircraft, space or life support equipment, nor in applications where failure or malfunction of an AWINIC Technology product can reasonably be expected to result in personal injury, death or severe property or environmental damage. AWINIC Technology accepts no liability for inclusion and/or use of AWINIC Technology products in such equipment or applications and therefore such inclusion and/or use is at the customer's own risk.

Applications that are described herein for any of these products are for illustrative purposes only. AWINIC Technology makes no representation or warranty that such applications will be suitable for the specified use without further testing or modification.

All products are sold subject to the general terms and conditions of commercial sale supplied at the time of order acknowledgement.

Nothing in this document may be interpreted or construed as an offer to sell products that is open for acceptance or the grant, conveyance or implication of any license under any copyrights, patents or other industrial or intellectual property rights.

Reproduction of AWINIC information in AWINIC data books or data sheets is permissible only if reproduction is without alteration and is accompanied by all associated warranties, conditions, limitations, and notices. AWINIC is not responsible or liable for such altered documentation. Information of third parties may be subject to additional restrictions.

Resale of AWINIC components or services with statements different from or beyond the parameters stated by AWINIC for that component or service voids all express and any implied warranties for the associated AWINIC component or service and is an unfair and deceptive business practice. AWINIC is not responsible or liable for any such statements.