

CD4013 CMOS Dual D-Type Flip-Flop

1. General Description

1.1 Description

The CD4013 device consists of two identical, independent data-type flip-flops. Each flip-flop has independent data, set, reset, and clock inputs and Q and \bar{Q} outputs. These devices can be used for shift register applications, and, by connecting \bar{Q} output to the data input, for counter and toggle applications. The logic level present at the D input is transferred to the Q output during the positive-going transition of the clock pulse. Setting or resetting is independent of the clock and is accomplished by a high level on the set or reset line, respectively.

1.2 Features

- Asynchronous set-reset capability
- Static flip-flop operation
- Standardized symmetrical output characteristics
- 100% tested for quiescent current at 18V
- Maximum input current of 1 μ A at 18V and 25 $^{\circ}$ C
- 5V, 10V, and 15V parametric ratings

1.3 Device Information

PART NUMBER	PACKAGE
CD4013	DIP
	SOP
	TSSOP

2. Pin Description and Functional Diagram

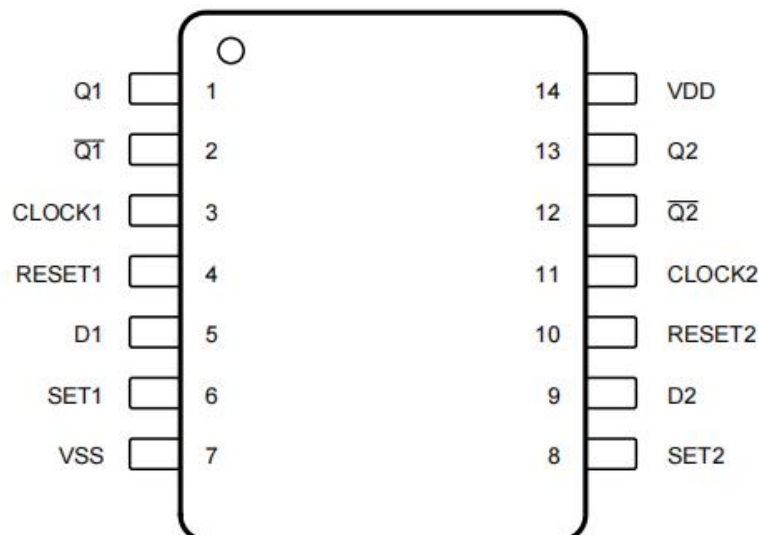

Figure 2.1 Top View

PIN No.	NAME	I/O	FUNCTION
1	Q1	O	Channel 1 Output
2	$\overline{Q1}$	O	Inverted Channel 1 Output
3	CLOCK1	I	Channel 1 Clock Input
4	RESET1	I	Channel 1 Reset Input
5	D1	I	Channel 1 Data Input
6	SET1	I	Channel 1 Set Input
7	VSS		Ground
8	SET2	I	Channel 2 Set Input
9	D2	I	Channel 2 Data Input
10	RESET2	I	Channel 2 Reset Input
11	CLOCK2	I	Channel 2 Clock Input
12	$\overline{Q2}$	O	Inverted Channel 2 Output
13	Q2	O	Channel 2 Output
14	VDD		Supply Voltage

3. System Diagram

3.1 Logic Diagram

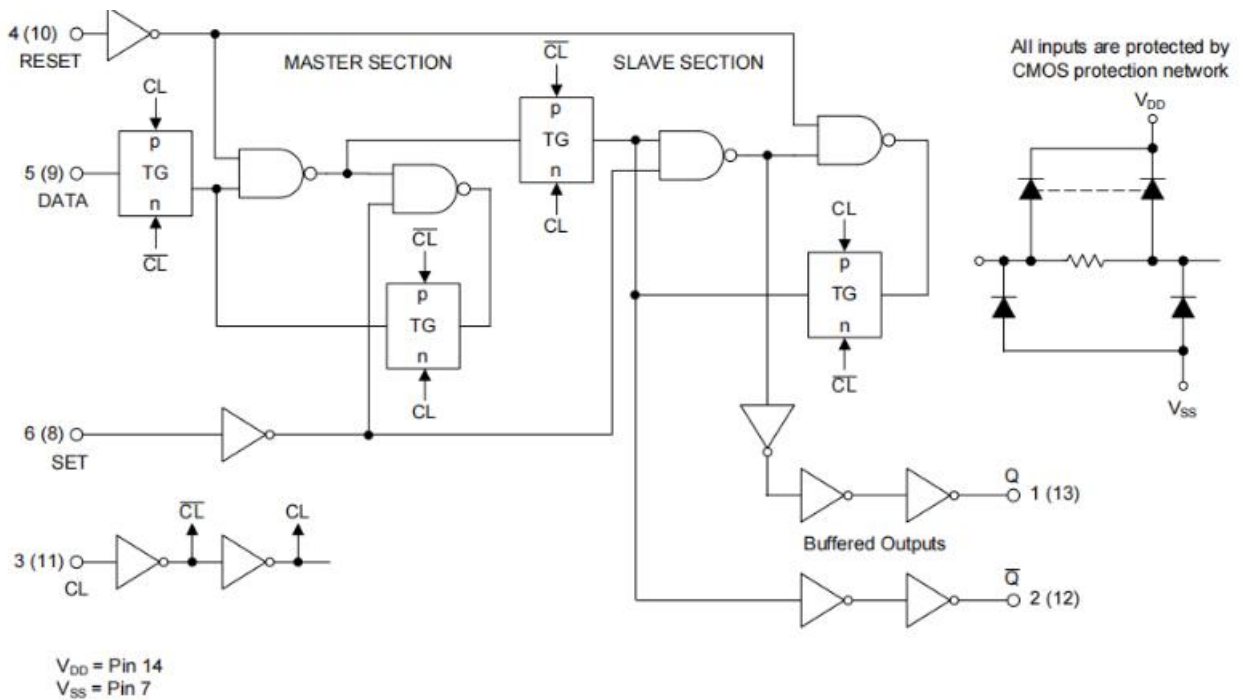

Figure 3.1: CD4013 Logic Diagram



3.2 Function Table

Input				Output	
CLOCK	SET	RESET	D	Q	\overline{Q}
↑	0	0	0	0	1
↑	0	0	1	1	0
↓	0	0	X	Q ₀	\overline{Q}
X	0	1	X	0	1
X	1	0	X	1	0
X	1	1	X	1	1

X = don't care, 1≡High State, 0≡Low State,↑=positive-going transition,↓=negative-going transition

4. Specifications

4.1 Absolute Maximum Ratings

Symbol	Parameter	MIN	MAX	Unit
V _{DD}	DC Supply Voltage Range (Voltage Referenced to VSS Terminals)	-0.5	20	V
V _i	Input Voltage Range, All Inputs	0.5	V _{DD} +0.5	V
P _D	Power Dissipation		500	mW
T _J	Junction Temperature		125	°C
T _{OP}	Operating Temperature	-40	85	°C

Absolute maximum ratings are those values beyond which the device could be permanently damaged, These are stress ratings only, which do not imply functional operation of the device at these or any other conditions beyond those indicated under normal operating conditions.

4.2 Electrical Characteristics

(T_a=25°C, voltages are referenced to VSS (ground=0V), unless otherwise specified)

Symbol	Parameter	Test Condition			MIN	TYP	MAX	Unit
		V _O	V _{IN}	V _{DD}				
I _{DD}	Supply Current	--	0,5	5	--	0	1	uA
		--	0,10	10	--	0	1	uA
		--	0,18	18	--	0	1	uA
I _{OL}	Low Level Output Current	0.4	0,5	5	0.5	1.5	--	mA
		0.5	0,10	10	1	2.5	--	mA
		1.5	0,15	15	4	8	--	mA
I _{OH}	High Level Output Current	4.6	0,5	5	-0.5	-1.5	--	mA
		2.5	0,5	5	-3	-6	--	mA
		9.5	0,10	10	-1.5	-3	--	mA
		13.5	0,15	15	-5	-10	--	mA
V _{OL}	Low Level Output Voltage	--	0,5	5	--	0	0.05	V
		--	0,10	10	--	0	0.05	V
		--	0,15	15	--	0	0.05	V



Symbol	Parameter	Test Condition			MIN	TYP	MAX	Unit
		VO	VIN	VDD				
V _{OH}	High Level Output Voltage	--	0,5	5	4.95	5	--	V
		--	0,10	10	9.95	10	--	V
		--	0,15	15	14.95	15	--	V
V _{IL}	Low Level Input Voltage	0.5,4.5	--	5	--	--	1.5	V
		1,9	--	10	--	--	3	V
		1.5,13.5	--	15	--	--	4	V
V _{IH}	High Level Input Voltage	0.5,4.5	--	5	3.5	--	--	V
		1,9	--	10	7	--	--	V
		1.5,13.5	--	15	11	--	--	V
I _{IN}	Input Leakage Current	--	0,18	18	--	0	±1	uA

5. Ordering Information

Orderable Device	Package Type	Pins	Packing	Package Qty
CD4013ND14ATBE	DIP	14	Tube	25
CD4013NS14ARDQ	SOP	14	Tape & Reel	4000
CD4013TS14ARDQ	TSSOP	14	Tape & Reel	4000

6. Package Information

6.1 DIP14

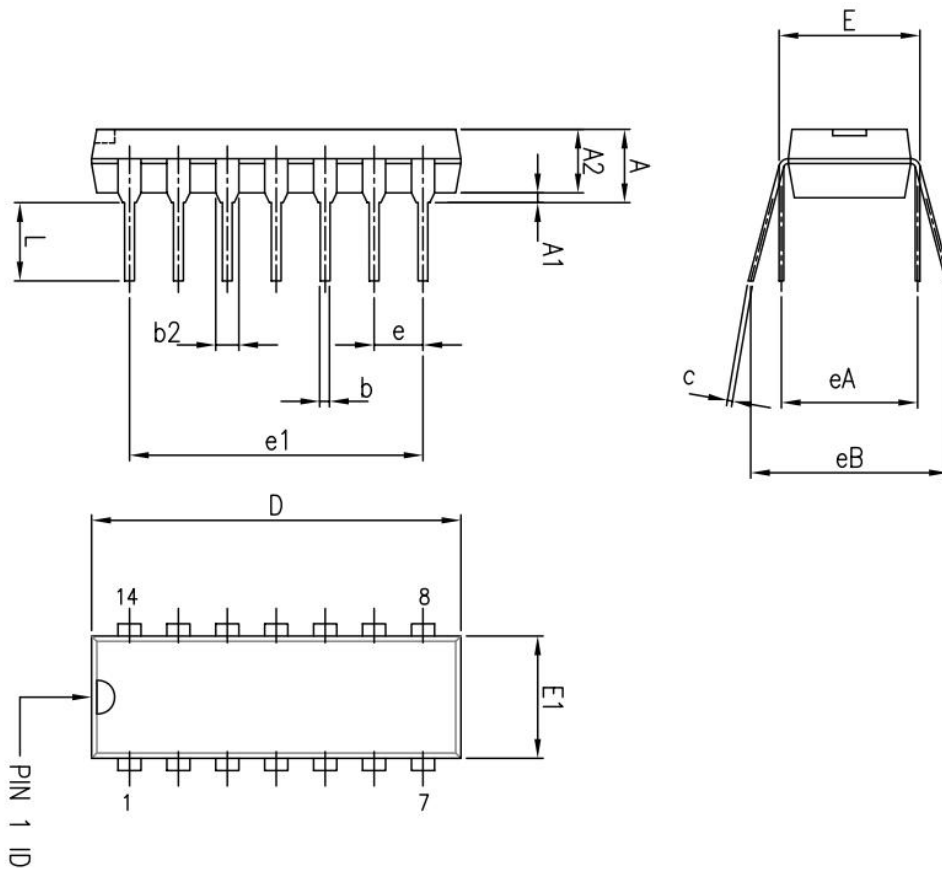

Dimensions						
Ref.	Millimeters			Inches		
	Min.	Typ.	Max.	Min.	Typ.	Max.
A			5.33			0.21
A1	0.38			0.015		
A2	2.92	3.30	4.95	0.11	0.13	0.19
b	0.36	0.46	0.56	0.014	0.018	0.022
b2	1.14	1.52	1.78	0.04	0.06	0.07
c	0.20	0.25	0.36	0.007	0.009	0.01
D	18.67	19.05	19.69	0.73	0.75	0.77
E	7.62	7.87	8.26	0.30	0.31	0.32
E1	6.10	6.35	7.11	0.24	0.25	0.28
e		2.54			0.10	
e1		15.24			0.60	
eA		7.62			0.30	
eB			10.92			0.43
L	2.92	3.30	3.81	0.11	0.13	0.15

6.2 SOP14

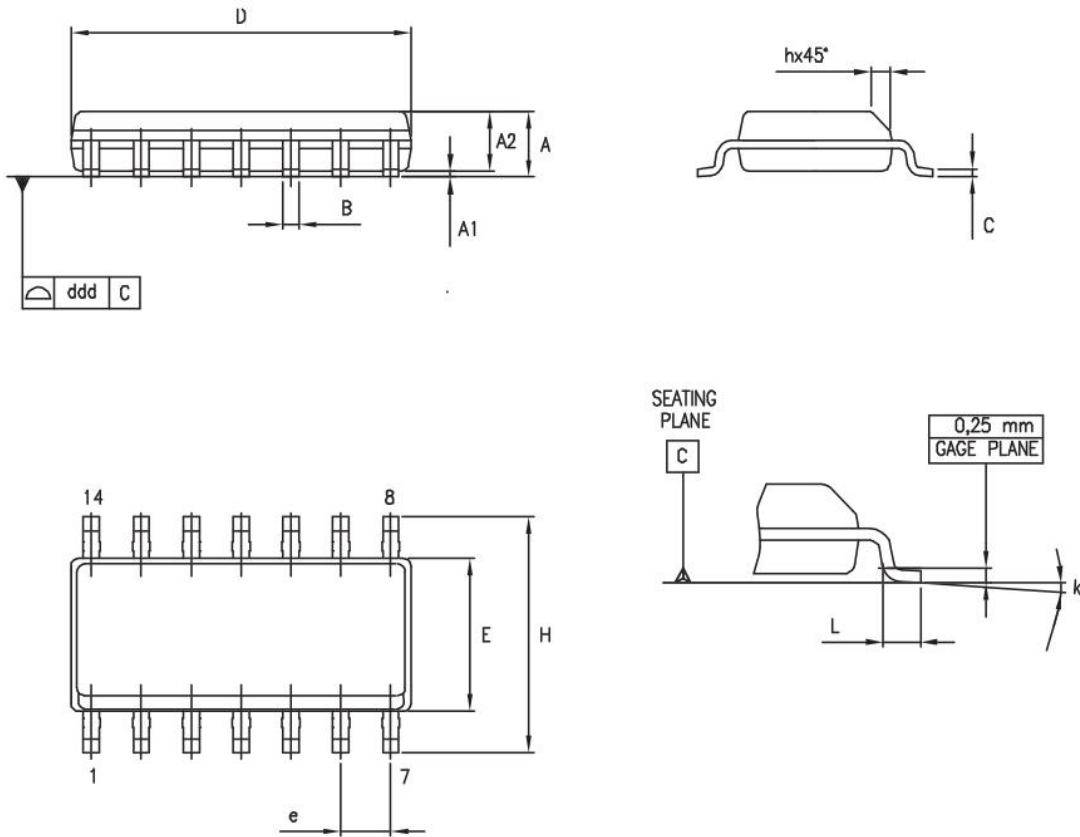

Dimensions						
Ref.	Millimeters			Inches		
	Min.	Typ.	Max.	Min.	Typ.	Max.
A	1.35		1.75	0.05		0.068
A1	0.10		0.25	0.004		0.009
A2	1.10		1.65	0.04		0.06
B	0.33		0.51	0.01		0.02
C	0.19		0.25	0.007		0.009
D	8.55		8.75	0.33		0.34
E	3.80		4.0	0.15		0.15
e		1.27			0.05	
H	5.80		6.20	0.22		0.24
h	0.25		0.50	0.009		0.02
L	0.40		1.27	0.015		0.05
k	8° (max.)					
ddd			0.10			0.004

6.3 TSSOP14

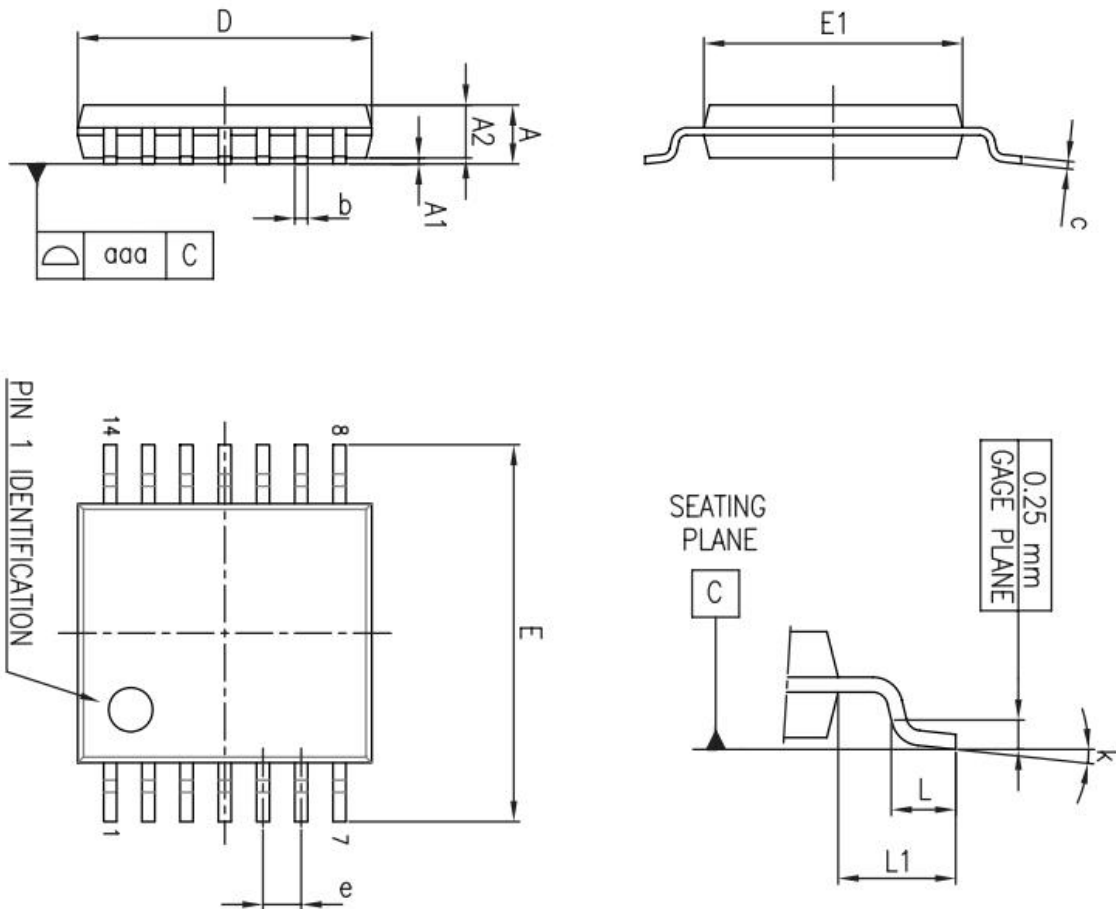

Ref.	Dimensions					
	Millimeters			Inches		
	Min.	Typ.	Max.	Min.	Typ.	Max.
A			1.20			0.047
A1	0.05		0.15	0.002	0.004	0.006
A2	0.80	1.00	1.05	0.031	0.039	0.041
b	0.19		0.30	0.007		0.012
c	0.09		0.20	0.004		0.0089
D	4.90	5.00	5.10	0.193	0.197	0.201
E	6.20	6.40	6.60	0.244	0.252	0.260
E1	4.30	4.40	4.50	0.169	0.173	0.176
e		0.65			0.0256	
L	0.45	0.60	0.75	0.018	0.024	0.030
L1		1.00			0.039	
k	0°		8°	0°		8°
aaa			0.10			0.004