

## Power Distribution Switch with Fixed Current Limit

### Features

- Integrated P-channel MOSFET power switch
- Input voltage: 2.5V to 5.5V
- Fix current limit
- Switch on-resistance(typ.):  
R<sub>dson</sub>=65mΩ at V<sub>IN</sub>=5V
- ±10% current limit accuracy
- Reverse current protection
- Internal EN pull-down/up resistor
- Under voltage lockout
- Over temperature protection
- Quick Output Discharge(QOD)
- SOT23-5L package
- Certificated by UL(AW35045CD/45LCD)  
UL62368-1: 2021, file no. E542176
- Certificated by CB(AW35045CD/45LCD)  
IEC62368-1:2018, file no. E542176

### Applications

USB Ports

Power Distribution Switch

Notebook and Desktop Computer

High-Definition Television(HDTV)

### Typical Application Circuit

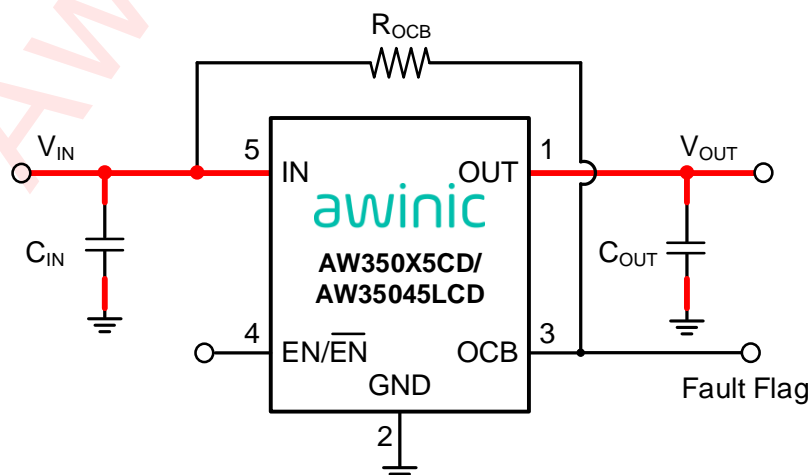

Figure 1 Typical Application Circuit of AW350X5CD/45LCD

### General Description

The AW350X5CD/45LCD is a P-channel MOSFET power distribution switch which intended for high-side load-switching applications. The device integrates current limit function to protect power source from over current and short circuit condition. Besides, a flag output is available to indicate fault conditions.

The AW350X5CD/45LCD also features fast short-circuit response, under voltage lockout, over temperature protection, reverse current protection. The AW350X5CD/45LCD builds in quick output discharge function.

Fixed current limit selection table:

AW35025CD	1.1A fixed current limit
AW35035CD	1.5A fixed current limit
AW35045CD AW35045LCD	2.1A fixed current limit
AW35055CD	2.5A fixed current limit

## Pin Configuration And Top Mark

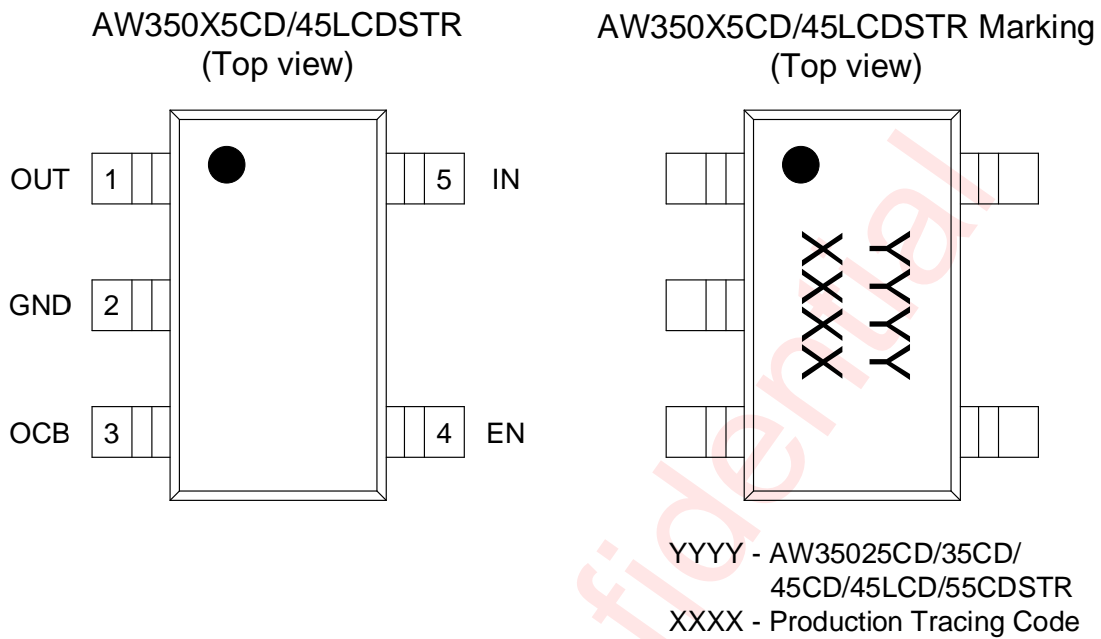

Figure 2 Pin Configuration and Top Mark

## Pin Definition

Pin	Name	Description
1	OUT	Output pin
2	GND	Ground
3	OCB	Fault flag output
4	EN/ $\overline{\text{EN}}$	Chip enable (Active High/Low)
5	IN	Power supply input

## Functional Block Diagram

- For Enable Active High Version(AW350X5CD)

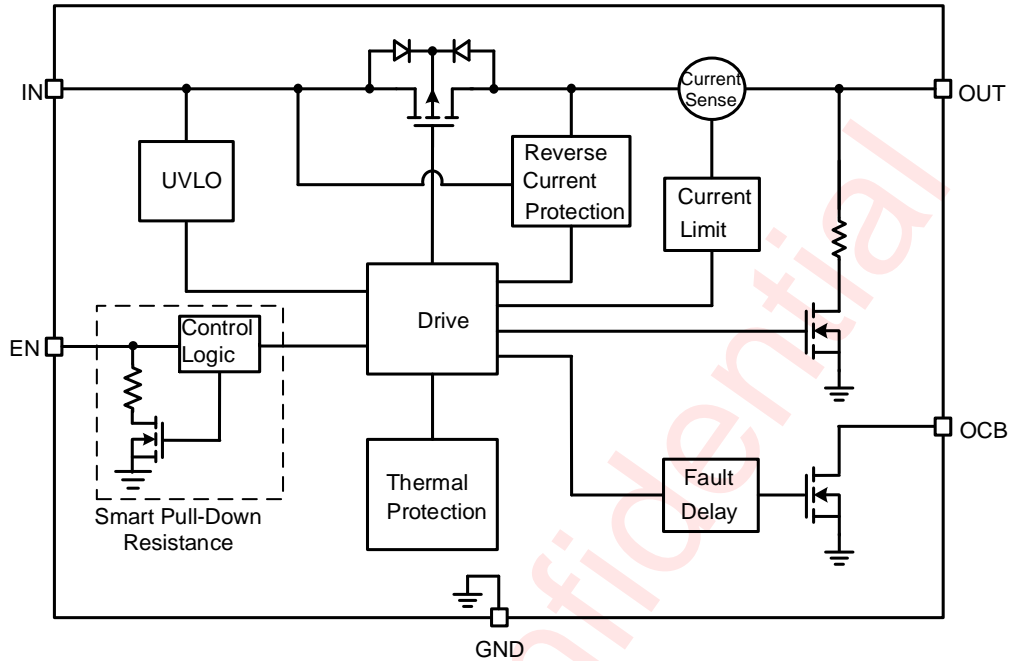

- For Enable Active Low Version(AW35045LCD)

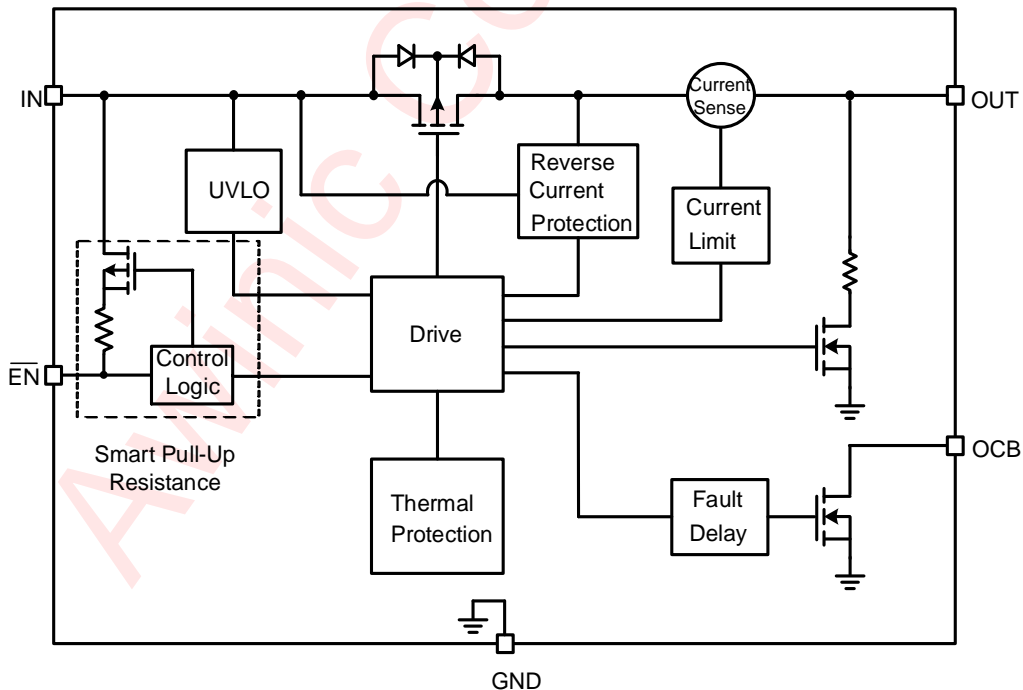

Figure 3 Functional Block Diagram

## Typical Application Circuits

- For Enable Active High Version

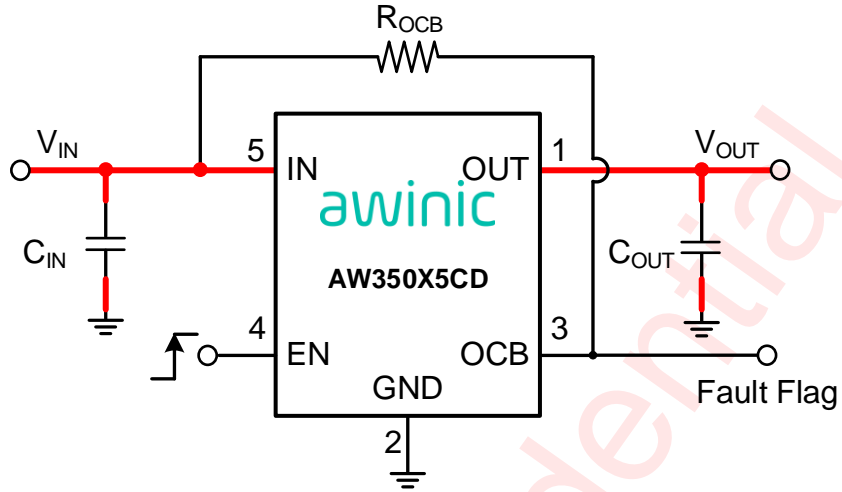

Figure 4 Typical Application Circuit of AW350X5CD

- For Enable Active Low Version

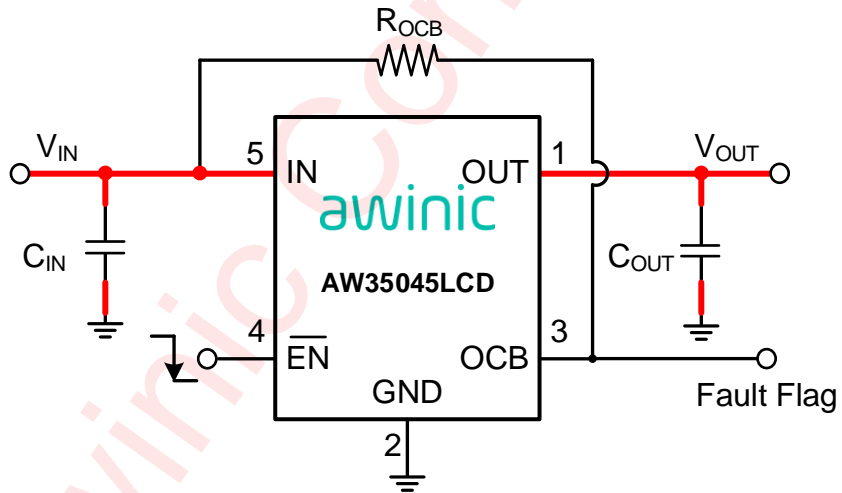

Figure 5 Typical Application Circuit of AW35045LCD

## Ordering Information

Part Number	Temperature	Package	Marking	Moisture Sensitivity Level	Environmental Information	Delivery Form
AW35025CDSTR	-40°C ~ 85°C	SOT23-5L	D8VA	MSL3	ROHS+HF	3000 units/ Tape and Reel
AW35035CDSTR	-40°C ~ 85°C	SOT23-5L	D72K	MSL3	ROHS+HF	3000 units/ Tape and Reel
AW35045CDSTR	-40°C ~ 85°C	SOT23-5L	K63T	MSL3	ROHS+HF	3000 units/ Tape and Reel
AW35045LCDSTR	-40°C ~ 85°C	SOT23-5L	62HA	MSL3	ROHS+HF	3000 units/ Tape and Reel
AW35055CDSTR	-40°C ~ 85°C	SOT23-5L	6G6L	MSL3	ROHS+HF	3000 units/ Tape and Reel

**Absolute Maximum Ratings**<sup>(NOTE1)</sup>

PARAMETERS		RANGE
Supply Voltage Range $V_{IN}$		-0.3V to 6V
EN Voltage Range	EN	-0.3V to 6V
Output Voltage Range	OUT	-0.3V to 6V
Maximum Continuous Switch Current for $V_{IN} \geq 2.5V$ <sup>(NOTE 2)</sup>		2.5A
Maximum Peak Switch Current for $V_{IN} \geq 2.5V$ <sup>(NOTE 3)</sup>		2.8A
Junction-to-ambient thermal resistance $\theta_{JA}$ <sup>(NOTE 4)</sup>		158.9°C/W
Junction-to-case thermal resistance $\theta_{JC}$		57°C/W
Operating Free-air Temperature Range		-40°C to 85°C
Maximum Junction Temperature $T_{JMAX}$		150°C
Storage Temperature $T_{STG}$		-65°C to 150°C
Lead Temperature (Soldering 10 Seconds)		260°C
ESD		
HBM (Human Body Model) <sup>(NOTE 5)</sup>		±2kV
CDM(Charged Device Model) <sup>(NOTE 6)</sup>		±1.5kV
Latch-Up		
Test Condition: JEDEC78E.		+IT: 200mA -IT: -200mA

**NOTE1:** Conditions out of those ranges listed in "absolute maximum ratings" may cause permanent damages to the device. In spite of the limits above, functional operation conditions of the device should within the ranges listed in "recommended operating conditions". Exposure to absolute-maximum-rated conditions for prolonged periods may affect device reliability.

**NOTE2:** Limited by thermal design.

**NOTE3:** Limited by thermal design, and tested in 10ms width pulse current.

**NOTE4:** Thermal resistances follow JEDEC 2S2P standards, and is usually highly dependent on PCB layout.

**NOTE5:** The human body model is a 100pF capacitor discharged through a 1.5kΩ resistor into each pin. Test method: ESDA/JEDEC JS-001-2017.

**NOTE6:** All pins. Test Condition: ESDA/JEDEC JS-002-2018.

**Recommended Operating Conditions**

Symbol	Parameter	Min.	Typ.	Max.	Unit
$V_{IN}$	Input Voltage	2.5		5.5	V
$V_{EN}$	EN Voltage	0		5.5	V
$V_{OUT}$	Output Voltage	0		$V_{IN}$	V
$C_{IN}$	Input capacitance	0.1	1		μF
$C_{OUT}$	Output capacitance	0.1	1		μF

## Electrical Characteristics

T<sub>A</sub> = 25°C unless otherwise noted. Typical values are guaranteed for V<sub>IN</sub> = 5V, C<sub>IN</sub> = 1μF, I<sub>IN</sub> ≤ 2.5A.

PARAMETER		TEST CONDITION	MIN	TYP	MAX	UNIT	
<b>SUPPLY CURRENT</b>							
I <sub>Q</sub>	Input quiescent current	V <sub>IN</sub> =5.0V, EN(EN)=Active, I <sub>OUT</sub> =0A		30		μA	
I <sub>SD</sub>	Shutdown current from IN to GND	V <sub>IN</sub> =5.0V, EN(EN)=Inactive		0.32	1	μA	
I <sub>LEAKEN</sub>	EN pin leakage current	V <sub>IN</sub> =0V, V <sub>EN</sub> =5.5V		0.52	1	μA	
<b>POWER SWITCH</b>							
R <sub>dson</sub>	Internal switch MOSFET on-state resistance	V <sub>IN</sub> =5.0V, I <sub>OUT</sub> =500mA		65		mΩ	
R <sub>EN</sub>	EN pin pull down resistor	V <sub>IN</sub> =5V, V <sub>EN</sub> =0.1V (AW350X5CD)		9.2		MΩ	
	EN pin pull up resistor	V <sub>IN</sub> =5V, V <sub>EN</sub> =3V (AW35045LCD)					
R <sub>DIS</sub>	Output discharge resistance	V <sub>IN</sub> =5.0V, EN(EN)=Inactive, I <sub>OUT</sub> Sinking 2mA		75		Ω	
t <sub>R</sub>	Output rise time	V <sub>IN</sub> =5.0V, C <sub>OUT</sub> =1μF, R <sub>L</sub> =100Ω		1.5		ms	
t <sub>ON</sub>	Switch turn on time			2.3		ms	
t <sub>F</sub>	Output fall time			93		μs	
t <sub>OFF</sub>	Switch turn off time			99		μs	
V <sub>IH</sub>	EN input high threshold level		1.4			V	
V <sub>IL</sub>	EN input low threshold level				0.4	V	
<b>CURRENT LIMIT</b>							
I <sub>LIMIT</sub>	Current limit threshold	V <sub>OUT</sub> =4V	AW35025CD	1100	1225	1350	mA
			AW35035CD	1500	1665	1830	
			AW35045CD/45LCD	2100	2335	2570	
			AW35055CD	2500	2780	3060	
t <sub>IOS</sub>	Response time to short circuit	V <sub>IN</sub> =5.0V			10		μs
t <sub>OCF</sub>	Current-limit response time	V <sub>IN</sub> =5.0V, I <sub>OUT</sub> =1.5 × I <sub>LIMIT</sub>			100		μs
<b>UNDER VOLTAGE LOCKOUT</b>							
V <sub>UVLO</sub>	UVLO threshold voltage	V <sub>IN</sub> rising			2.3	2.5	V
V <sub>UVLO_HYS</sub>	UVLO hysteresis	V <sub>IN</sub> falling			95		mV

**Electrical Characteristics (Continued)**

$T_A = 25^\circ\text{C}$  unless otherwise noted. Typical values are guaranteed for  $V_{IN} = 5\text{V}$ ,  $C_{IN} = 1\mu\text{F}$ ,  $I_{IN} \leq 2.5\text{A}$ .

PARAMETER		TEST CONDITION	MIN	TYP	MAX	UNIT
<b>REVERSE VOLTAGE PROTECT</b>						
$V_{REV}$	Reverse voltage trip point	$\overline{\text{EN}}(\overline{\text{EN}})=\text{Active}, V_{\text{OUT}} > V_{\text{IN}}$		43		mV
$I_{REV}$	Reverse leakage current	$V_{\text{OUT}}=5\text{V}, V_{\text{IN}}=0\text{V}, \overline{\text{EN}}(\overline{\text{EN}})=\text{Inactive}$		0.68		$\mu\text{A}$
$I_{REV\_ACT}$	Reverse activation current	$V_{\text{IN}}=5\text{V}, C_{\text{OUT}}=1\mu\text{F}, V_{\text{OUT}} > V_{\text{IN}}$		0.6		A
$I_{REV\_PRO}$	Reverse protection current	$V_{\text{OUT}} - V_{\text{IN}} > V_{REV}$		5		$\mu\text{A}$
<b>FAULT FLAG</b>						
$R_{OCB}$	OCB output low Resistance	$V_{\text{IN}}=5\text{V}, I_{\text{SINK}}=1\text{mA}$		190		$\Omega$
$I_{LEAK\_OCB}$	OCB off-state leakage current	$V_{OCB}=5.5\text{V}$		0.03		$\mu\text{A}$
$t_{OCB}$	OCB delay time	$V_{\text{IN}}=5\text{V}$ , From fault condition to OCB assertion		2		ms
<b>THERMAL PROTECTION</b>						
$T_{SD}$	Thermal shutdown threshold			155		$^\circ\text{C}$
$T_{SD\_HYS}$	Thermal shutdown hysteresis			25		$^\circ\text{C}$

## Timing Diagram

- For Enable Active High Version

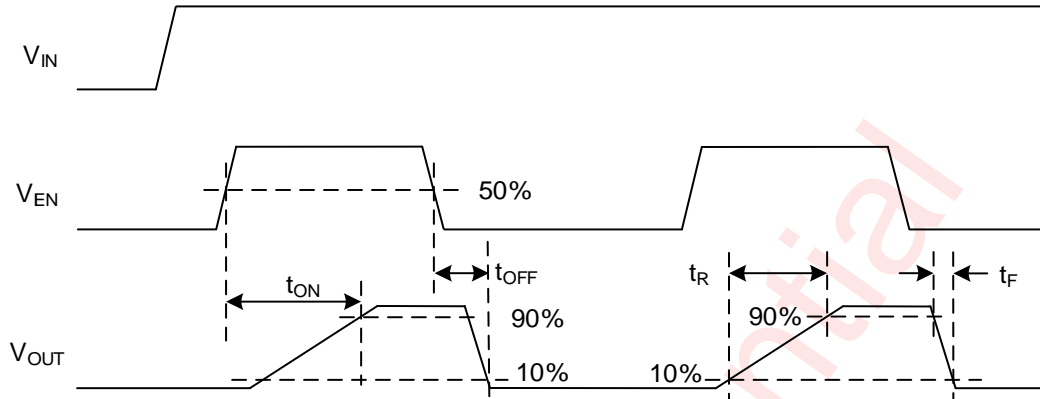

Figure 6 AW350X5CD Timing Diagram

- For Enable Active Low Version

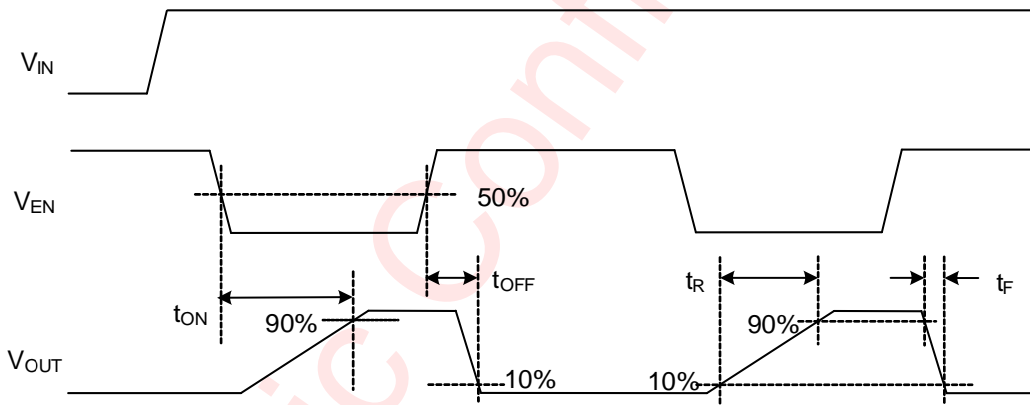

Figure 7 AW35045LCD Timing Diagram

## Typical Characteristics

Ambient temperature is 25°C,  $C_{IN} = C_{OUT} = 1\mu F$ , unless otherwise noted.

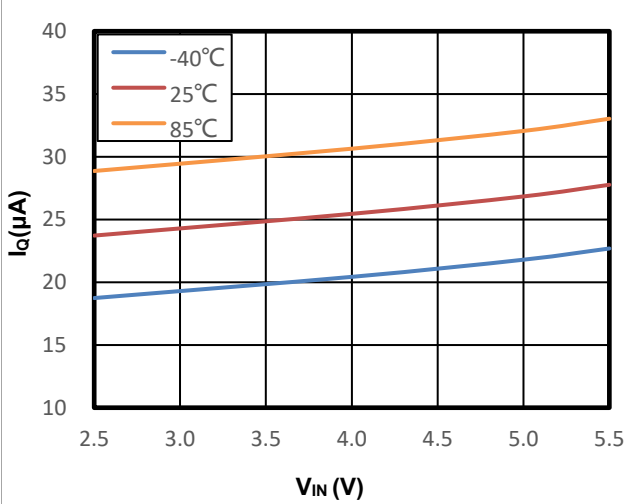

Figure 8 Quiescent Current vs. V<sub>IN</sub>, No load

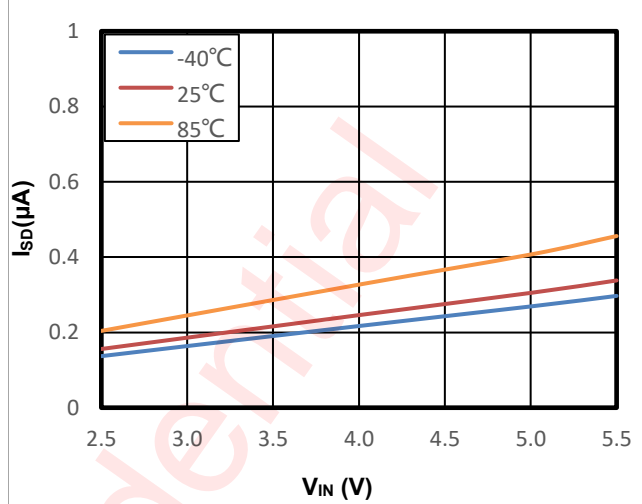

Figure 9 IN Shutdown Current vs. V<sub>IN</sub>

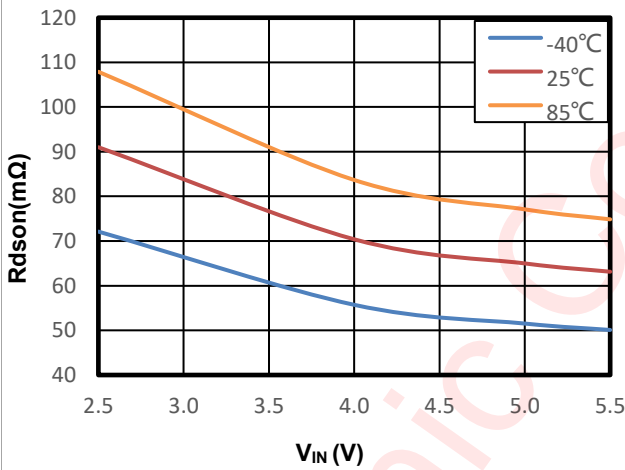

Figure 10 Rdson vs. V<sub>IN</sub> (I<sub>OUT</sub>=500mA)

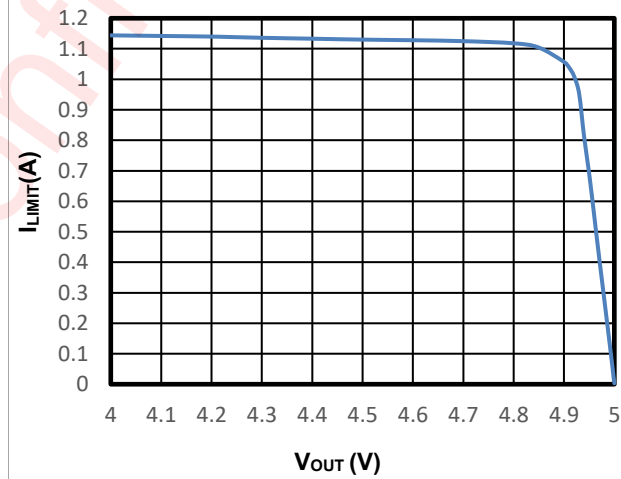

Figure 11 I<sub>LIMIT</sub> vs. V<sub>OUT</sub>  
(AW35025CD)

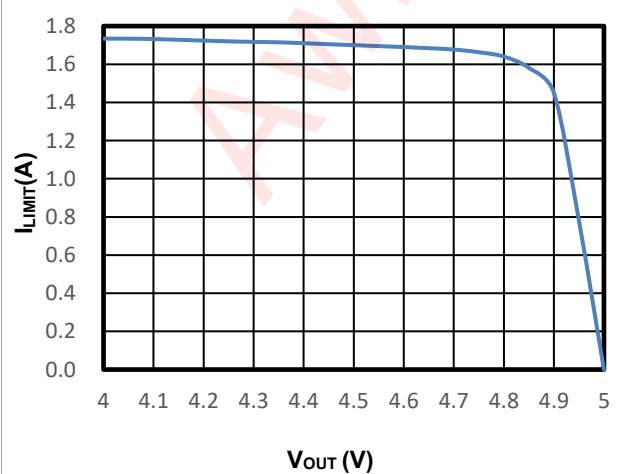

Figure 12 I<sub>LIMIT</sub> vs. V<sub>OUT</sub>  
(AW35035CD)

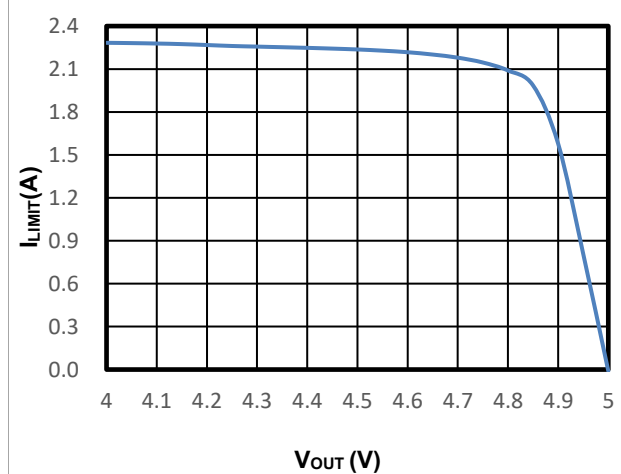
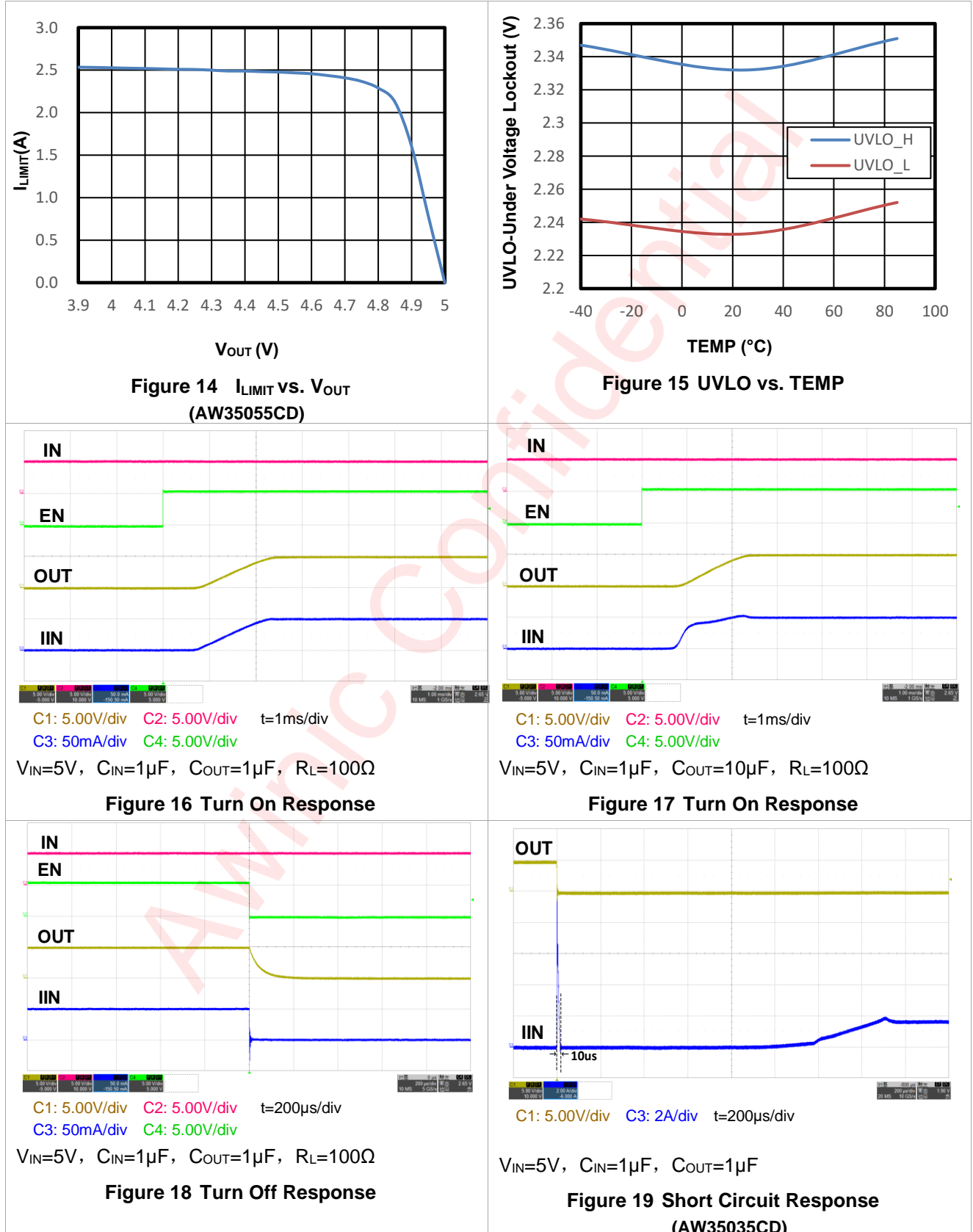
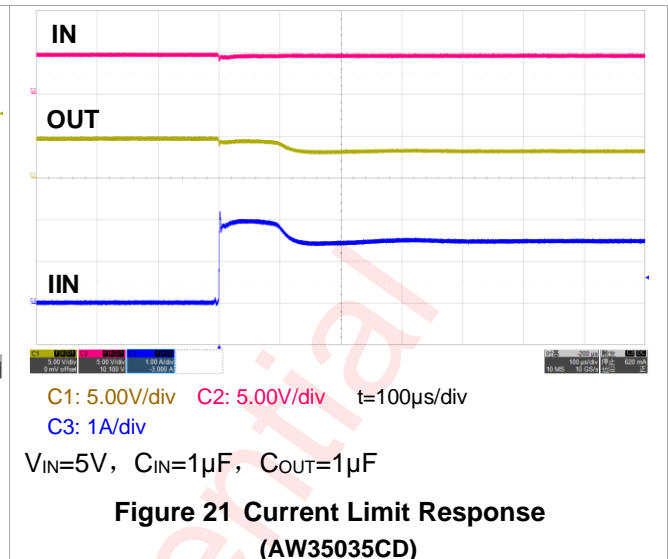
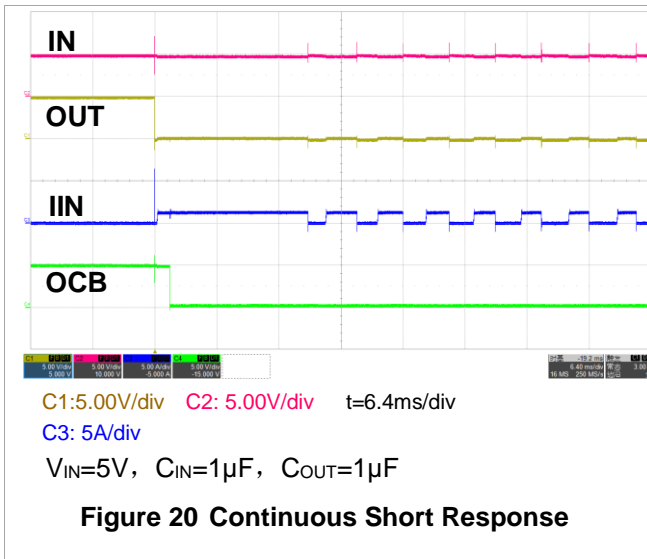

Figure 13 I<sub>LIMIT</sub> vs. V<sub>OUT</sub>  
(AW35045CD/45LCD)

## Typical Characteristics (continued)

Ambient temperature is 25°C,  $C_{IN} = C_{OUT} = 1\mu F$ , unless otherwise noted.





## Functional Description

The AW350X5CD/AW35045LCD is a P channel MOSFET power distribution switch with current limit function. In addition, the switch also features fast short-circuit response, under voltage lockout, over temperature protection and reverse current protection.

### Current Limit Threshold Setting

The AW350X5CD/AW35045LCD provides fixed current limit threshold. The current limit function can prevent the switch from over current condition.

AW35025CD	1.1A fixed current limit
AW35035CD	1.5A fixed current limit
AW35045CD/45LCD	2.1A fixed current limit
AW35055CD	2.5A fixed current limit

### Fast Short Circuit Protection

The AW350X5CD/AW35045LCD provides short circuit protection function which can limit the output current to a safe level without damaging the switch.

### Under Voltage Lockout (UVLO)

The AW350X5CD/AW35045LCD has under voltage lockout function which can disable the switch until the input voltage reaches the UVLO threshold (typical 2.3V). The UVLO threshold has a 95mV hysteresis voltage which can prevent the unwanted on/off cycling when there is noise on the input voltage.

### Over Temperature Protection (OTP)

When the junction temperature exceeds 155°C, the internal OTP circuit turn off the power switch. There is a temperature hysteresis 25°C, in other words, the OTP circuit can turn on the switch only if the junction temperature is below 130°C.

## Quick Output Discharge

The AW350X5CD/AW35045LCD include the Quick Output Discharge (QOD) feature, in order to discharge the application capacitor connected on OUT pin. When EN pin is set to low level, a discharge resistance with a typical value of  $75\Omega$  is connected between the output and ground, pull down the output and prevent it from floating when the device is disabled.

## Reverse Current Protection (RCP)

The AW350X5CD/AW35045LCD includes the Reverse Current Protection(RCP) function, which can prevent the current to flowing through the P-FET or the body diode when  $V_{OUT}$  greater than  $V_{IN}$ . Whatever the switch is on or off, the AW350X5CD/AW35045LCD always has this function. When  $V_{OUT}-V_{IN}$  greater than  $V_{REV}$ , the internal comparator quickly turns off the switch, in order to prevent large reverse current from  $V_{OUT}$  to  $V_{IN}$ . The switch will return to normal operation once the reverse voltage scenario disappeared.

The  $I_{REV\_ACT}$  parameter in the Figure 22 can be calculated by the following formula: 
$$I_{REV\_ACT} = \frac{V_{REV}}{R_{dson}}$$

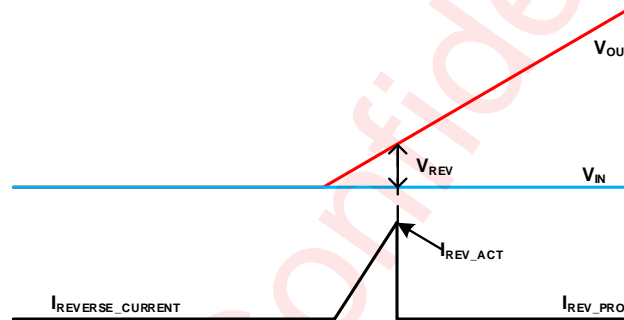

Figure 22 RCP parameter diagram

## OCB Output

The AW350X5CD/AW35045LCD provides an open-drain output to indicate that a fault condition has occurred. When any of over current or over temperature or reverse current protection occurs for a deglitch time of  $t_{OCB}$ , the OCB goes low. If fault condition remove, OCB will goes high. Connect a resistor to between OCB and  $V_{IN}$  for normal work.

## Application Information

### Input and Output Capacitor Selection

Input and output capacitance improves the performance of the device, the actual capacitance should be optimized for the particular application. For all applications, a  $1\mu\text{F}$  or greater ceramic bypass capacitor between IN and GND is recommended as close to the device as possible for local noise de-coupling. This precaution reduces ringing on the input due to power-supply transients. Additional input capacitance may be needed on the input to reduce voltage overshoot from exceeding the absolute maximum voltage of the device during heavy transient conditions.

Placing a  $1\mu\text{F}$  or greater ceramic capacitor on the output pin is recommended when large transient currents are expected on the output.

## PCB Layout Consideration

AW350X5CD/AW35045LCD is a low ON-Resistance power switch, to obtain the optimal performance, PCB layout should be considered carefully. Here are some guidelines:

1. All the peripherals should be placed as close to the device as possible. Place the input capacitor  $C_{IN}$  on the top layer (same layer as the AW350X5CD/AW35045LCD) and close to IN pin, and place the output capacitor  $C_{OUT}$  on the top layer (same layer as the AW350X5CD/AW35045LCD) and close to OUT pin.
2. AW350X5CD/AW35045LCD integrates an up to 2.5A rated PMOS FET, and the PCB design rules must be respected to properly evacuate the heat out of the silicon. By increasing PCB area, especially around IN and OUT pins, the  $R_{\theta JA}$  of the package can be decreased, allowing higher power dissipation. Blue bold paths on Figure 23 are power lines that will flow large current, please route them on PCB as straight, wide and short as possible.
3. Use rounded corners on the power trace from the power supply connector to AW350X5CD/45LCD to decrease EMI coupling.

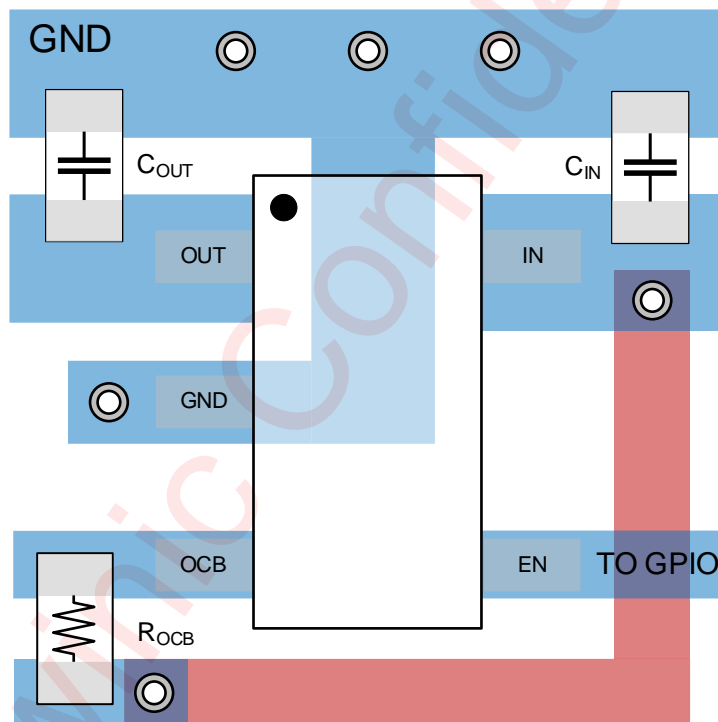
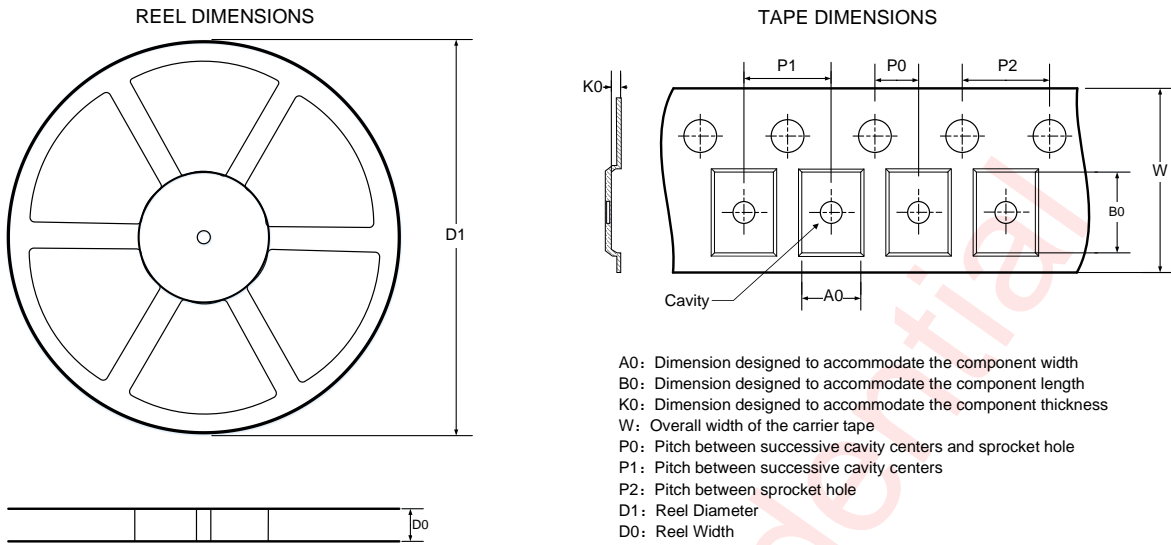
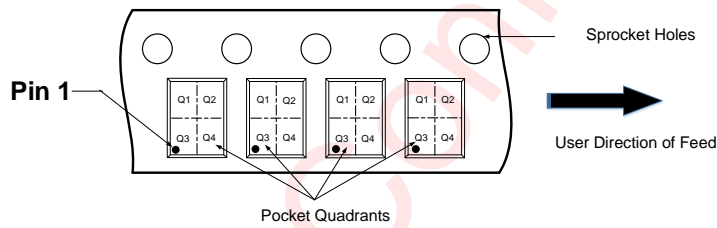

Figure 23 PCB layout example

## Tape And Reel Information



### QUADRANT ASSIGNMENTS FOR PIN 1 ORIENTATION IN TAPE



Note: The above picture is for reference only. Please refer to the value in the table below for the actual size

### DIMENSIONS AND PIN1 ORIENTATION

D1 (mm)	D0 (mm)	A0 (mm)	B0 (mm)	K0 (mm)	P0 (mm)	P1 (mm)	P2 (mm)	W (mm)	Pin1 Quadrant
178	8.5	3.3	3.2	1.4	2	4	4	8	Q3

All dimensions are nominal

Package Description

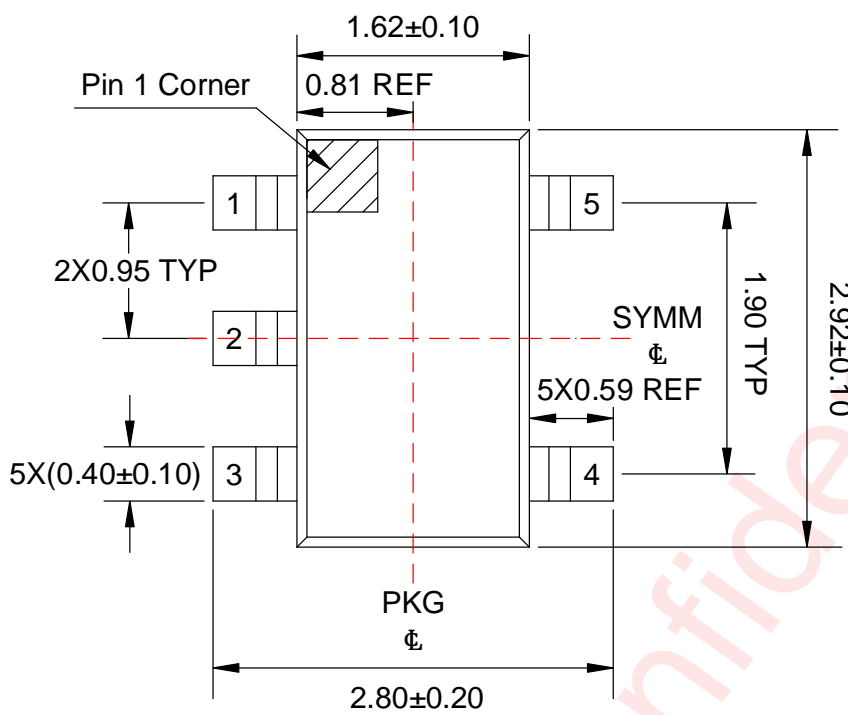

Top View

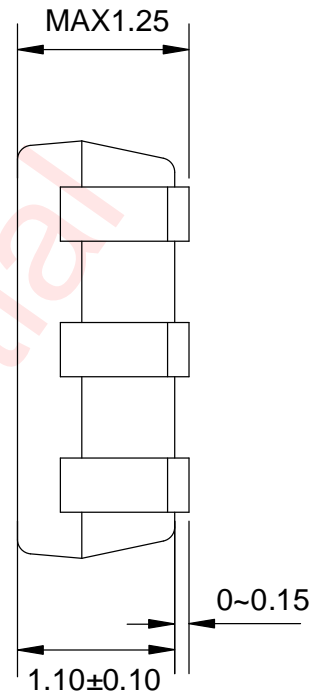

Side View

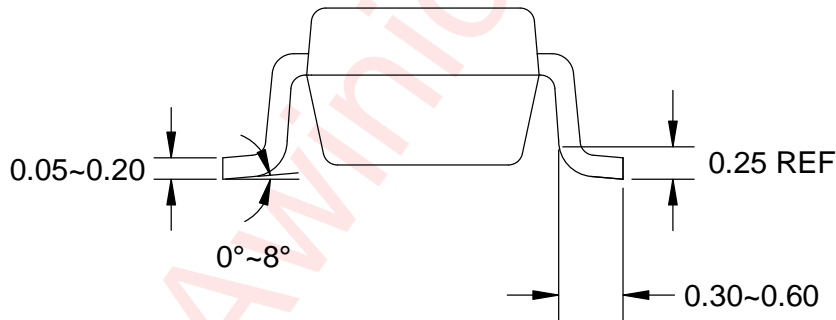

Side View

Unit: mm

Land Pattern Data

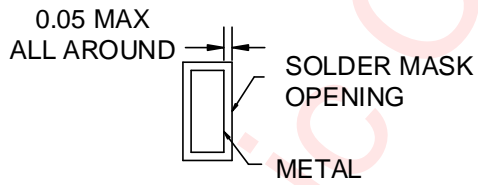
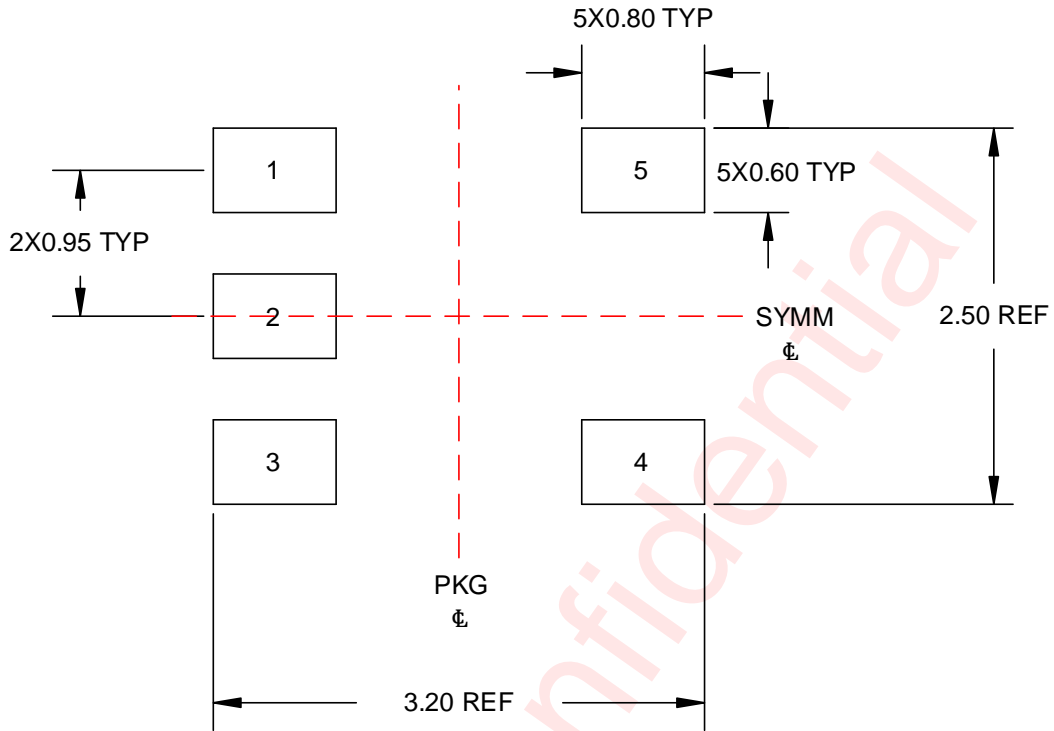

NON SOLDER MASK DEFINED

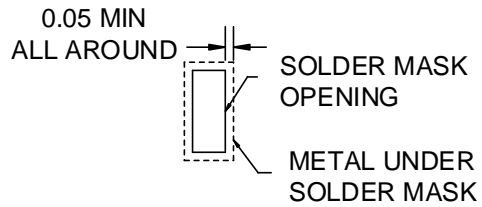

SOLDER MASK DEFINED

Unit: mm

## Revision History

Version	Date	Change Record
V1.0	Mar. 2025	Officially released

Awinic Confidential

## Disclaimer

All trademarks are the property of their respective owners. Information in this document is believed to be accurate and reliable. However, Shanghai AWINIC Technology Co., Ltd (AWINIC Technology) does not give any representations or warranties, expressed or implied, as to the accuracy or completeness of such information and shall have no liability for the consequences of use of such information.

AWINIC Technology reserves the right to make changes to information published in this document, including without limitation specifications and product descriptions, at any time and without notice. Customers shall obtain the latest relevant information before placing orders and shall verify that such information is current and complete. This document supersedes and replaces all information supplied prior to the publication hereof.

AWINIC Technology products are not designed, authorized or warranted to be suitable for use in medical, military, aircraft, space or life support equipment, nor in applications where failure or malfunction of an AWINIC Technology product can reasonably be expected to result in personal injury, death or severe property or environmental damage. AWINIC Technology accepts no liability for inclusion and/or use of AWINIC Technology products in such equipment or applications and therefore such inclusion and/or use is at the customer's own risk.

Applications that are described herein for any of these products are for illustrative purposes only. AWINIC Technology makes no representation or warranty that such applications will be suitable for the specified use without further testing or modification.

All products are sold subject to the general terms and conditions of commercial sale supplied at the time of order acknowledgement.

Nothing in this document may be interpreted or construed as an offer to sell products that is open for acceptance or the grant, conveyance or implication of any license under any copyrights, patents or other industrial or intellectual property rights.

Reproduction of AWINIC information in AWINIC data books or data sheets is permissible only if reproduction is without alteration and is accompanied by all associated warranties, conditions, limitations, and notices. AWINIC is not responsible or liable for such altered documentation. Information of third parties may be subject to additional restrictions.

Resale of AWINIC components or services with statements different from or beyond the parameters stated by AWINIC for that component or service voids all express and any implied warranties for the associated AWINIC component or service and is an unfair and deceptive business practice. AWINIC is not responsible or liable for any such statements.