

NCV7535

SPI Controlled H-bridge and Dual-Half Bridge Pre-Driver

The NCV7535 is a monolithic SPI controlled H-bridge pre-driver providing control of a DC-motor. Thanks to the SPI interface, it includes enhanced feature set useful in automotive systems. This allows a highly integrated solution.

Features

- Main Supply Functional Operating Range from 5 V to 28 V
- Main Supply Parametrical Operating Range 6 V to 18 V
- Active and Standby Operating Modes
- Compatible to Low-ohmic Standard Level N-channel MOSFETs
- Enhanced Charge Pump for Internal High-side Supply
- Specific Pin for N-channel MOSFET Reverse Battery Protection
- Programmable Slew-rate, Dead-time and Over-current Level
- PWM Operation up to 25 kHz
- Active or Passive Freewheeling
- High-side or Low-side Freewheeling
- Configurable into Single H-bridge or Dual Half-bridges Mode
- 24-Bit SPI Interface
- Protection Against Short-circuit, Over-voltage, Under-voltage and Over-temperature
- TSSOP20 Package
- AEC-Q100 Qualified and PPAP Capable
- This is a Pb-free Device

Typical Applications

- Replacing Systems with Relays by MOSFETs
- Motor Drivers



ON Semiconductor®

www.onsemi.com

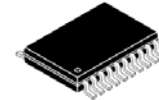

TSSOP20
CASE 948AD

MARKING DIAGRAM

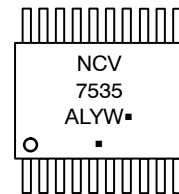

- A = Assembly Location
- L = Wafer Lot
- Y = Year
- W = Work Week
- = Pb-Free Package

(Note: Microdot may be in either location)

PIN CONNECTIONS

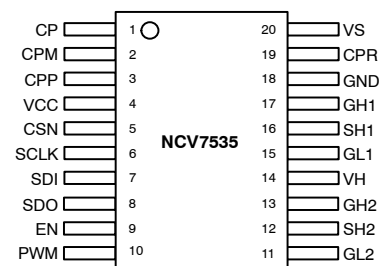

ORDERING INFORMATION

Device	Package	Shipping†
NCV7535DBR2G	TSSOP20 (Pb-Free)	2500 / Tape & Reel

†For information on tape and reel specifications, including part orientation and tape sizes, please refer to our Tape and Reel Packaging Specification Brochure, BRD8011/D.

NCV7535

Table 1. PIN FUNCTION DESCRIPTION

Pin No.	Pin Name	Pin Type	Description
1	CP	Analog output	Charge pump output for high-side gate drive supply
2	CPM	Analog output	Minus terminal for pump capacitor
3	CPP	Analog output	Plus terminal for pump capacitor
4	VCC	supply input	Logic supply of the device
5	CSN	Digital input with pull-up	SPI chip select input
6	SCLK	Digital input with pull-down	SPI clock input
7	SDI	Digital input with pull-down	SPI data input
8	SDO	Digital push-pull output, tristate	SPI data output
9	EN	Digital input with pull-down	Enable input
10	PWM	Digital input with pull-down	Input for pulse width modulated driver duty cycle
11	GL2	Analog output	Output to gate of low-side switch 2
12	SH2	Analog input output	Connection to source of high-side switch 2
13	GH2	Analog output	Output to gate of high-side switch 2
14	VH	Analog input	Connection to drain of high-side switched for short circuit detection
15	GL1	Analog output	Output to gate of low-side switch 1
16	SH1	Analog input output	Connection to source of high-side switch 1
17	GH1	Analog output	Output to gate of high-side switch 1
18	GND	Ground	Ground connection
19	CPR	Analog output	Reverse Polarity N-FET Control Output
20	VS	Battery supply input	Power-supply of the device

NCV7535

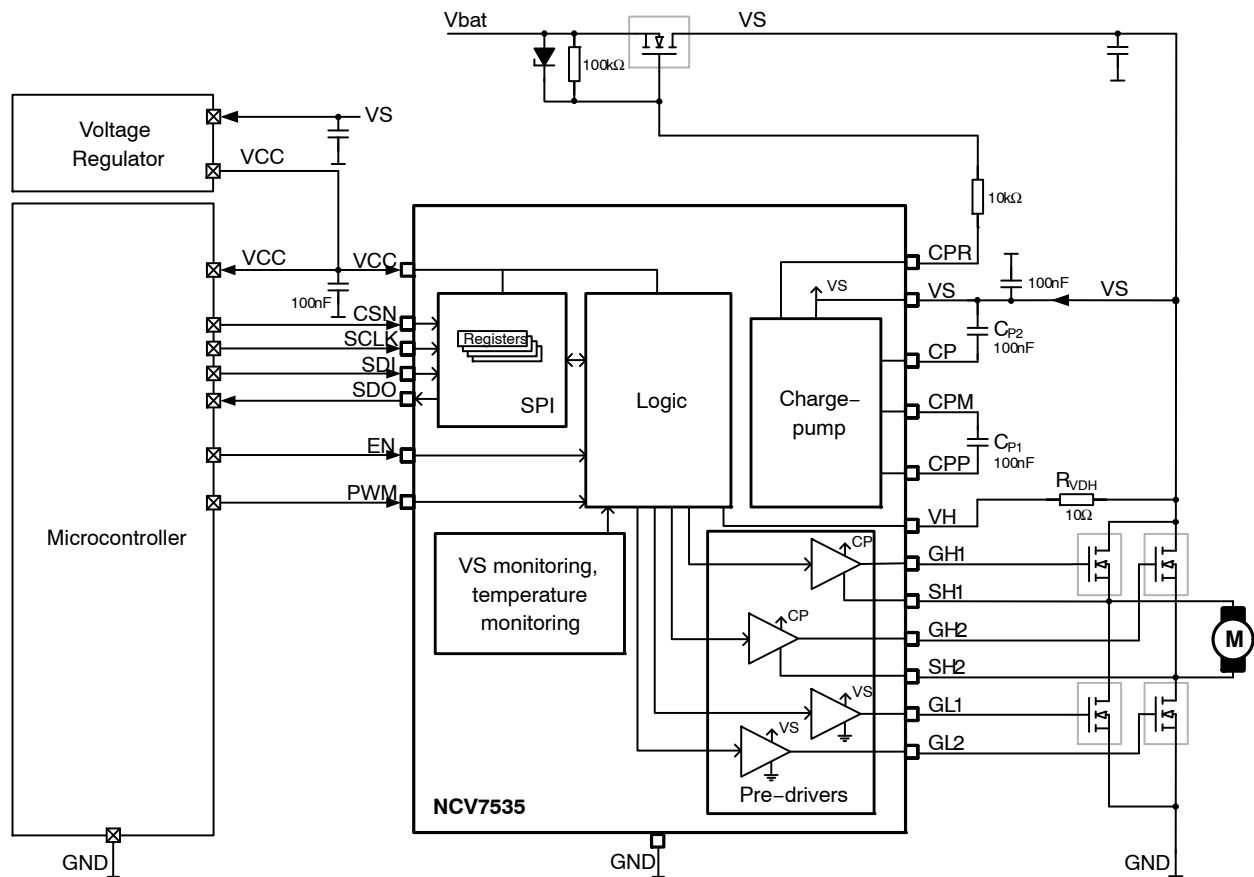

Figure 1. Block Diagram and Typical Application Diagram

Table 2. ABSOLUTE MAXIMUM RATINGS

Symbol	Parameter	Min	Max	Units
Vmax_VS	Power supply voltage	-0.3	40	V
Vmax_CPR	Reverse Polarity FET Control Output Voltage	-25 Vs - 25	40 Vs + 16	V
Vmax_CP, CPP	Positive Charge-pump CP and CPP voltages	-0.3	40	V
Vmax_CPM	Negative Charge-pump voltage	-0.3	VS + 0.3	V
Vmax_GHx, SHx	Gate driver voltage transient < 500 ns Gate driver voltage DC	-4 -2	40 VS + 0.3	V
Vmax_VGSx	Voltage difference V(GHx) - V(SHx) (high side Vgs), Qgate = 60 nC	-0.3	17 VS + 0.3	V
Vmax_GLx	GLx pin voltage transient (low side Vgs) < 500 ns GLx pin voltage DC, Qgate = 60nC	-0.3	17 VS + 0.3	V
Vmax_VH	Sense line for VS	-0.3	40	V
Vmax_VCC	Logic supply	-0.3	5.5	V
Vmax_digIO	DC voltage at digital pins - SDI, SDO, SCLK, PWM - CSN, EN	-0.3 -0.3	VCC + 0.3 5.8	V
Iinj_digIO	Injection current into VCC-related digital pins (SDI, SCLK, PWM)		1	mA
MSL	Moisture Sensitivity Level		3	

Stresses exceeding those listed in the Maximum Ratings table may damage the device. If any of these limits are exceeded, device functionality should not be assumed, damage may occur and reliability may be affected.

Table 3. THERMAL CHARACTERISTICS

Symbol	Parameter	Value	Units
$R_{\theta JL}$ $R_{\theta JA}$	Thermal Characteristics Thermal Resistance, Junction-to-Lead Thermal Reference, Junction-to-Ambient	60 130 (Note 1)	°C/W

1. Values represent typical still air steady-state thermal performance on 1 oz. copper FR4 PCB 4 layers with 650 mm² copper area

Table 4. OPERATING RANGES

Symbol	Parameter	Min	Max	Units
Vop_VS_par,	Power supply voltage for valid parameter specifications	6	18	V
Vop_VS_func, VH	Power supply for correct functional behavior (see Note 2)	5	28	V
Vop_VGSx	Voltage difference GHx – SHx (Vgs), Qgate = 60 nC	0	17	V
Vop_GLx	GLx pin voltage range DC, Qgate = 60 nC (voltage internally limited during flyback)	0	17	V
Vop_VCC	Logic supply	4.5	5.25	V
Vop_digIO	DC voltage at digital pins (SDI, SDO, SCLK, CSN, PWM, EN)	0	VCC	V
Tj_op	Junction temperature	-40	+150	°C

Functional operation above the stresses listed in the Recommended Operating Ranges is not implied. Extended exposure to stresses beyond the Recommended Operating Ranges limits may affect device reliability.

2. The device must see a VS voltage above VS Under-voltage (Vuv_vs) and below VS Over-voltage (Vov_vs) detection levels to drive the H-bridge normally.

Table 5. ELECTRICAL CHARACTERISTICS

6 V ≤ VS ≤ 18 V, 4.5 V ≤ VCC ≤ 5.25 V, -40°C ≤ Tj ≤ 150°C; unless otherwise specified

Symbol	Parameter	Test Conditions	Min	Typ	Max	Unit
VS, Vcc Supplies						
VS	Supply Voltage	Functional (see Note 3)	5		28	V
		Parameter specification	6		18	
I_VS_Standby	VS consumption in Standby mode	Standby mode, VS = 12 V, VCC = 0 V or EN = 0, Charge-pump off No SPI communication, Tj = 85°C (see Note 4)		10	20	μA
I_Vcc_Standby	Vcc consumption in Standby mode	Standby mode, VS = 12 V, VCC = 5 V, EN = 0, Charge-pump off No SPI communication, Tj = 85°C (see Note 4)		10	20	μA
I_VS_Active	VS consumption in Active mode	Active mode, VS = 12 V, VCC = 5 V, external H-bridge static, No SPI communication fPWM = 25 kHz, Qg = 60 nC			4 10	mA mA
I_Vcc_Active	Vcc consumption in Active mode	Active mode		3.3	8	mA

Overvoltage and Undervoltage Detection

Vuv_vs(on)	VS Under-Voltage detection	VS increasing	5.6		6.4	V
Vuv_vs(off)		VS decreasing	5.0		5.7	
Vuv_vs(hys)	VS Under-Voltage hysteresis	Vuv_vs(on) – Vuv_vs(off)		0.65		V

3. The device must see a VS voltage above VS Under-voltage (Vuv_vs) and below VS Over-voltage (Vov_vs) detection levels to drive the H-bridge normally.

4. The Load must not have path to VS

5. ICP is internal load due to H-bridge switching (no external load)

6. Internal propagation delay and re-synchronization time are not included

7. Over-current is not detected during the transitions

Table 5. ELECTRICAL CHARACTERISTICS

6 V ≤ VS ≤ 18 V, 4.5 V ≤ VCC ≤ 5.25 V, -40°C ≤ Tj ≤ 150°C; unless otherwise specified

Symbol	Parameter	Test Conditions	Min	Typ	Max	Unit
Vov_vs(off)	VS Over-Voltage detection	VS increasing	22.5	24	25.5	V
Vov_vs(on)		VS decreasing	20.5	22	23.5	
Vov_vs(hys)	VS Over-Voltage hysteresis	Vov_vs(off) – Vov_vs(on)		2		V
Vuv_vcc(off)	VCC Under-Voltage detection	VCC increasing		3.0	3.2	V
Vuv_vcc(on)		VCC decreasing	2.6	2.8		
Vuv_vcc(hys)	VCC Under-Voltage hysteresis	Vuv_vcc(off) – Vuv_vcc(on)		0.2		V
td_uvov	VS Under-Voltage / Over-Voltage filter time	Time to set the power supply fail bit UOV_OC in the Global Status Byte	48	76	125	μs

Charge-pump

fCP	Charge pump frequency		300	425	550	kHz
Vcp1	Charge pump output voltage1	VS > 10.5 V, Icp = -10 mA (see Note 5), Cp1 = Cp2 = 100 nF	VS+8		VS+15.1	V
Vcp2	Charge pump output voltage2	VS > 6 V, Icp = -5 mA, Cp1 = Cp2 = 100 nF	VS+4.5			V
R_CPR	Switch impedance between CPR and CP	tested at 0.5 mA	250	300	420	Ω
I_CPR	Current capability of Reverse Polarity Gate Control				1	mA

Gate Outputs

dVGx_fast	Slew Rate of gate driver	VS=13.5 V, SPI bit CONFIG.SRF=1, Gate charge ≤ 60 nC		30		V/μs
dVGx_slow	Slew Rate of gate driver	VS=13.5 V, SPI bit CONFIG.SRF=0, Gate charge ≤ 60 nC		5		V/μs
fPWM	PWM frequency				25	kHz
tprop	Propagation delay of PWM rising or falling edge to gate activation	Measured at 50% PWM input signal to 10% rising or 90% falling edge of the gates Measured with dVGxfast & 5 nF load	200	500	800	ns
tjitter	Jitter versus PWM rising or falling edge to gate activations	Measured at 50% PWM input signal to 10% rising or 90% falling edge of the gates Measured with dVGxfast & 5 nF load	-150	0	150	ns

3. The device must see a VS voltage above VS Under-voltage (Vuv_vs) and below VS Over-voltage (Vov_vs) detection levels to drive the H-bridge normally.
4. The Load must not have path to VS
5. ICP is internal load due to H-bridge switching (no external load)
6. Internal propagation delay and re-synchronization time are not included
7. Over-current is not detected during the transitions

Table 5. ELECTRICAL CHARACTERISTICS

6 V ≤ VS ≤ 18 V, 4.5 V ≤ VCC ≤ 5.25 V, -40°C ≤ Tj ≤ 150°C; unless otherwise specified

Symbol	Parameter	Test Conditions	Min	Typ	Max	Unit
tdLH	Additional cross conduction protection time, low-to-high transition (Note 6)	Programmable via SPI bits CONFIG.NOCRLH[3:0]	-33%	0.25 0.5 0.75 1 1.25 1.5 1.75 2 2.25 2.5 2.75 3 3.25 3.5 3.75 4	+33%	μs
tdHL	Additional cross conduction protection time, high-to-low transition (Note 6)	Programmable via SPI bits CONFIG.NOCRHL[3:0]	-33%	0.25 0.5 0.75 1 1.25 1.5 1.75 2 2.25 2.5 2.75 3 3.25 3.5 3.75 4	+33%	μs

Over Current Detection of the External H-bridge

Vthoc	Programmable Over-Current detection threshold of external Vds V(VH)-V(SHx) for high side and V(SHx) versus Ground for low side (Note 7)	Programmable via SPI bits CONFIG.OCTH[2:0]	-10% -0.03	0.25 0.5 0.75 1 1.25 1.5 1.75 2	+10% +0.03	V
t_oc	Filter time for OC protection (Note 7)		4	6	12	μs

Digital Inputs CSN, SCLK, PWM, SDI, EN

Vinl	Input low level	VCC = 5 V			30% VCC	V
Vinh	Input high level	VCC = 5 V	70% VCC			V

3. The device must see a VS voltage above VS Under-voltage (Vuv_vs) and below VS Over-voltage (Vov_vs) detection levels to drive the H-bridge normally.
4. The Load must not have path to VS
5. ICP is internal load due to H-bridge switching (no external load)
6. Internal propagation delay and re-synchronization time are not included
7. Over-current is not detected during the transitions

Table 5. ELECTRICAL CHARACTERISTICS

6 V ≤ VS ≤ 18 V, 4.5 V ≤ VCC ≤ 5.25 V, -40°C ≤ Tj ≤ 150°C; unless otherwise specified

Symbol	Parameter	Test Conditions	Min	Typ	Max	Unit
Vin_hyst	Input hysteresis	VCC = 5 V	6% VCC			V
Rcsn_pu	CSN pull-up resistor	VCC = 5 V, 0 V < Vcsn < 70% VCC	30	120	250	kΩ
Rsclk_pd	SCLK pull-down resistor	VCC = 5 V, Vsclk = 1.5 V	30	60	220	kΩ
Rsdi_pd	SDI pull-down resistor	VCC = 5 V, Vsdi = 1.5 V	30	60	220	kΩ
Rpwm_pd	PWM pull-down resistor	VCC = 5 V Vpwm = 1.5 V	30	60	220	kΩ
Ren_pd	EN pull-down resistor	VCC = 5 V Ven = 1.5 V	30	120	250	kΩ
Ccsn/sclk/pwm	Pin capacitance (not tested in production, based on design and characterization)	0 V < Vpin < VCC			10	pF

Digital Output SDO

Vsdol	Output low level	Isdo = 5 mA			20% VCC	V
Vsdoh	Output high level	Isdo = -5 mA	80% VCC			V
Ileak_sdo	Tristate leakage current	Vcsn = VCC, 0 V < Vsdo < VCC	-10		10	μA
Csdo	Tristate input capacitance (not tested, based on design and characterization)	Vcsn = VCC, 0 V < Vsdo < VCC			10	pF

Digital Inputs EN, CSN, SCLK, SDI; Timing

tsclk	Clock period	VCC = 5 V		1000		ns
tsclk_h	Clock high time		115			ns
tsclk_l	Clock low time		115			ns
tset_csn	CSN setup time, CSN low before rising edge of SCLK		400			ns
tset_sclk	SCLK setup time, SCLK low before rising edge of CSN		400			ns
tset_si	SDI setup time		200			ns
thold_si	SDI hold time		200			ns
tr_in	Rise time of input signal SDI, SCLK, CSN				100	ns
tf_in	Fall time of input signal SDI, SCLK, CSN				100	ns
tcsn_hi_stdby	Minimum CSN high time, switching from Standby mode			5	10	μs
tcsn_hi_min	Minimum CSN high time, Active mode			2	4	μs

3. The device must see a VS voltage above VS Under-voltage (Vuv_vs) and below VS Over-voltage (Vov_vs) detection levels to drive the H-bridge normally.
4. The Load must not have path to VS
5. ICP is internal load due to H-bridge switching (no external load)
6. Internal propagation delay and re-synchronization time are not included
7. Over-current is not detected during the transitions

Table 5. ELECTRICAL CHARACTERISTICS

6 V ≤ VS ≤ 18 V, 4.5 V ≤ VCC ≤ 5.25 V, -40°C ≤ Tj ≤ 150°C; unless otherwise specified

Symbol	Parameter	Test Conditions	Min	Typ	Max	Unit
ten_neg	Minimum EN negative pulse which is seen as 0 (after synchronization)		325			ns
tcsn_hi_en_hi	Minimum time between CSN high and EN high edge		100			ns
ten_hi_csn_lo	Minimum time between EN high and CSN low edge		100			ns

Operating Modes Timing

tsact	Time delay from Standby (CSN rising edge MODE=1 and EN=1) into Active mode (NRDY=0)			240	340	μs
tacts	Time to place device from Active to Standby after rising edge CSN and MODE=0 or EN=0				13.5	μs
tsrt_stby	Time to place device back to Standby from Startup phase if after 1 st SPI communication MODE=0 or EN=0				8	μs

Thermal Protection

Tj _{sd_on}	Thermal shutdown threshold, Tj increasing	Junction temperature	160	175	195	°C
Tj _{sd_off}	Thermal shutdown threshold, Tj decreasing	Junction temperature	155			°C
Tj _{sd_hys}	Thermal shutdown hysteresis			5		°C
td_tx	Filter time for thermal shutdown	TSD Global Status bit	10		125	μs

3. The device must see a VS voltage above VS Under-voltage (Vuv_vs) and below VS Over-voltage (Vov_vs) detection levels to drive the H-bridge normally.
4. The Load must not have path to VS
5. ICP is internal load due to H-bridge switching (no external load)
6. Internal propagation delay and re-synchronization time are not included
7. Over-current is not detected during the transitions

Product parametric performance is indicated in the Electrical Characteristics for the listed test conditions, unless otherwise noted. Product performance may not be indicated by the Electrical Characteristics if operated under different conditions.

NCV7535

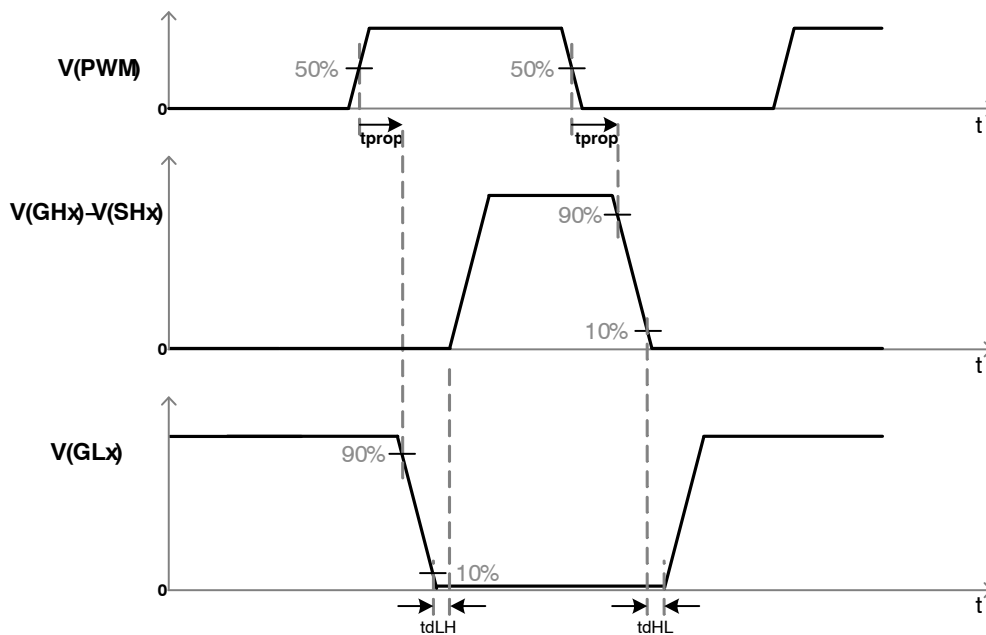

Figure 2. Cross Conduction Protection Timing

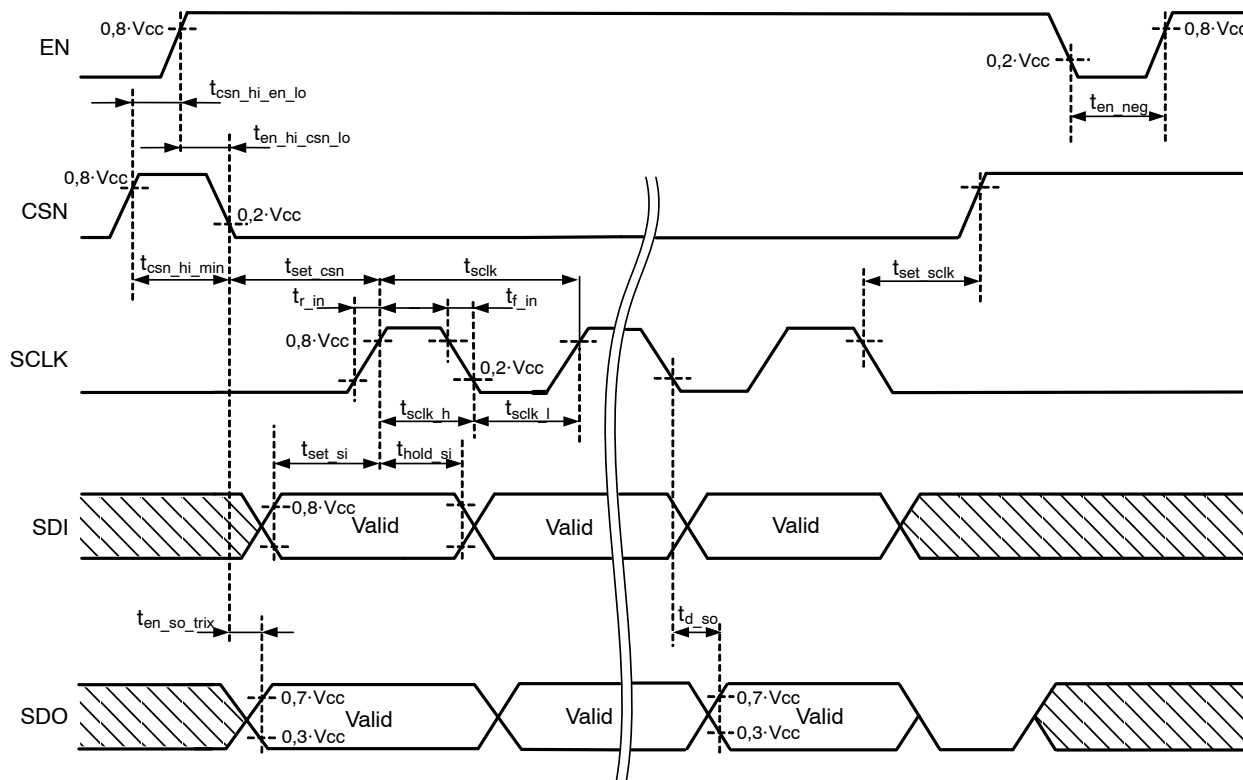

Figure 3. SPI Timing Parameters

Detailed Operating Description

Power Up/Down Control

In order to prevent uncontrolled operation of the device during power/up down, an under-voltage lockout feature is implemented. Both supply voltages (VCC and VS) are monitored for under-voltage conditions supporting a safe power-up transition. When VS drops below the under-voltage threshold $V_{uv_vs(off)}$ (VS under-voltage threshold) all output transistors are switched OFF.

Mode Control

Wake-up and Mode Control

Two different modes are available:

- Active mode
- Standby mode

After a power-up of VCC, the device starts in a Standby mode (VCC in Under-Voltage). Pulling the chip-select signal CSN to low level and pulling-up the enable signal EN to high level causes the device state to change into a Start-Up mode, waiting for setting SPI bit $CONTROL_0.MODE = 1$ (analog part active).

If bit MODE remains reset (0), the device returns to the Standby mode after an internal delay $tsrt_stby$, clearing all register content and keeping all output transistors OFF.

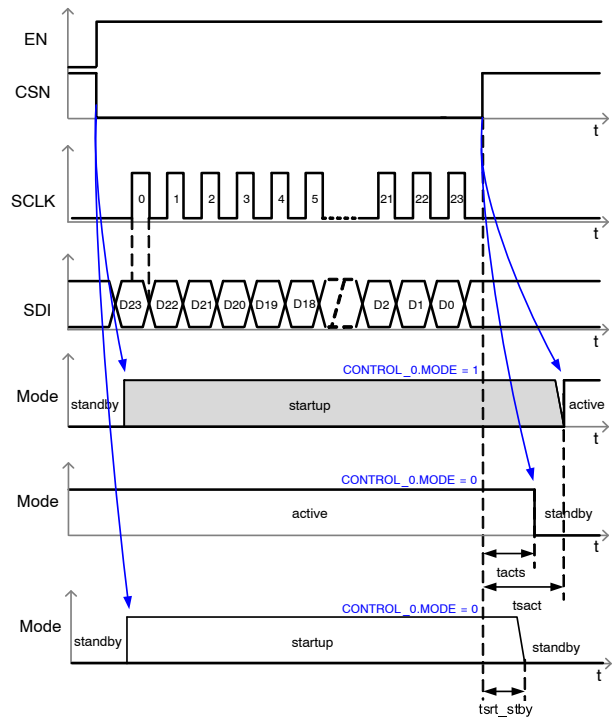

Figure 5. Mode Timing Diagram

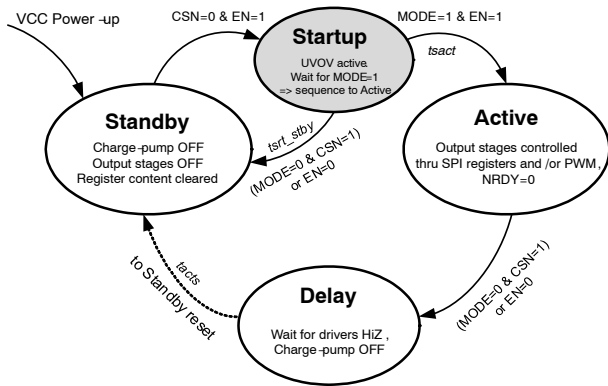

Figure 4. Mode Transitions Diagram

Cross-current Protection and PWM Control

The pre-drivers are protected against cross-currents by internal circuitry. If one driver is turned off (LS or HS), the activation of the other driver of the same output will be automatically delayed by the cross current protection mechanism until the active driver is safely turned off.

The Control signals required for the activations under PWM operation are described below:

PWM low will place the bridge into a freewheeling condition according to the $CONTROL_0.FWH$ bit setting:

- $FWH = 1$: “PWM low” will switch off the low side transistor and will, depending on FWA, turn on the high side ($FWA=1$) for active freewheeling or leave the transistor open ($FWA = 0$) for passive freewheeling
- $FWH = 0$: “PWM low” will switch off the high side transistor and will, depending on FWA, turn on the low side ($FWA=1$) for active freewheeling or leave the transistor open ($FWA = 0$) for passive freewheeling

The device can be used with SPI mode control only – then the PWM input pin must be forced to a high level.

		FWA=1 (Active free-wheeling)		FWA=0 (Passive free-wheeling)	
		PWM=1	PWM=0	PWM=1	PWM=0
HS1=1, HS2=0 LS1=0, LS2=1	FWH=1 (High-side free-wheeling)				
	FWH=0 (Low-side free-wheeling)				
HS1=0, HS2=1 LS1=1, LS2=0	FWH=1 (High-side free-wheeling)				
	FWH=0 (Low-side free-wheeling)				
HS1=0, HS2=0 LS1=1, LS2=1	FWH=x				
HS1=1, HS2=1 LS1=0, LS2=0	FWH=x				
Any other HS/ LS setting	FWH=x	All transistors off			

Figure 6. Bridge Configurations

Over-Voltage and Under-Voltage Shutdown

If the supply voltage VS rises above the switch off voltage $V_{ov_vs(off)}$ or falls below $V_{uv_vs(off)}$, all output transistors are switched OFF.

Over-Temperature Shutdown

The device provides an over-temperature protection. If the junction temperature rises above T_{jsd_on} threshold, the thermal shutdown bit TSD is set and all the output transistors are switched OFF. The shutdown delay for the over-temperature is t_{d_tx} . The output channels can be re-enabled after the device is cooled down and the TSD flag has been reset by the microcontroller by setting $CONTROL_0.MODE = 0$.

Over-Current Shutdown

Over Current is detected by the device when the drain-source voltage (Vds) of the external N-MOSFETs saturates. Above the Over-Current threshold (programmable via SPI register bits $CONFIG.OCTH[2:0]$), the over current is detected. During the bridge transitions, the error detection is masked (Vds can be higher than the OCTH during the slopes).

If the device is in full-bridge mode ($CONFIG.HALF_HB = 0$), the full bridge is disabled in case of over-current.

Otherwise, if the device is in half-bridge mode ($CONFIG.HALF_HB = 1$), only the half-bridge in affected by the over-current is disabled.

SPI Control

General Description

The 4-wire SPI interface establishes a full duplex synchronous serial communication link between the NCV7535 and the application's microcontroller. The NCV7535 always operates in slave mode whereas the controller provides the master function. A SPI access is performed by applying an active-low slave select signal at CSN. SDI is the data input, SDO the data output. The SPI master provides the clock to the NCV7535 via the SCLK input. The digital input data is sampled at the rising edge at SCLK. The data output SDO is in high impedance state (tri-state) when CSN is high. To readout the global error flag without sending a complete SPI frame, SDO indicates the corresponding value as soon as CSN is set to active. With the first rising edge at SCLK after the high-to-low transition of CSN, the content of the selected register is transferred into the output shift register.

The NCV7535 provides one control registers ($CONTROL_0$), one status register ($STATUS_0$) and one general configuration register ($CONFIG$). Each of these register contains 16-bit data, together with the 8-bit frame header (access type, register address), the SPI frame length is therefore 24 bits. In addition to the read/write accessible registers, the NCV7535 provides five 8-bit ID registers (ID_HEADER , $ID_VERSION$, $ID_CODE1/2$ and $ID_SPI-FRAME$) with 8-bit data length. The content of these registers can still be read out by a 24-bit access, the data is then transferred in the MSB section of the data frame.

SPI Frame Format

Figure 7 shows the general format of the NCV7535 SPI frame.

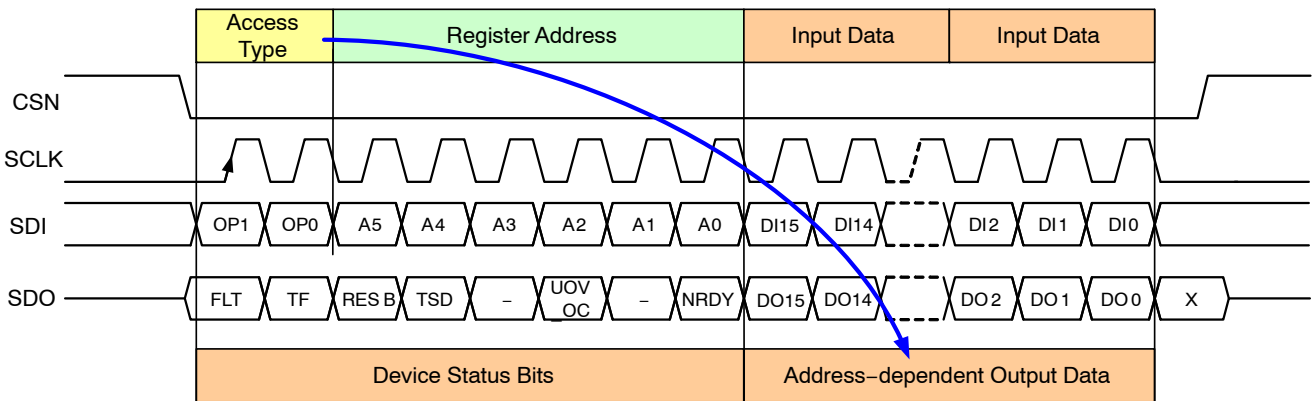

Figure 7. SPI Frame Format

24-bit SPI Interface

Both 24-bit input and output data are MSB first. Each SPI-input frame consists of a command byte followed by two data bytes. The data returned on SDO within the same frame always starts with the global status byte. It provides

general status information about the device. It is then followed by 2 data bytes (in-frame response) which content depends on the information transmitted in the command byte. For write access cycles, the global status byte is followed by the previous content of the addressed register.

Chip Select Not (CSN)

CSN is the SPI input pin which controls the data transfer of the device. When CSN is high, no data transfer is possible and the output pin SDO is set to high impedance. If CSN goes low, the serial data transfer is allowed and can be started. The communication ends when CSN goes high again.

Serial Clock (SCLK)

If CSN is set to low, the communication starts with the rising edge of the SCLK input pin. At each rising edge of SCLK, the data at the input pin Serial IN (SDI) is latched. The data is shifted out thru the data output pin SDO after the falling edges of SCLK. The clock SCLK must be active only within the frame time, means when CSN is low. The correct transmission is monitored by counting the number of clock pulses during the communication frame. If the number of SCLK pulses does not correspond to the frame width indicated in the SPI-frame-ID (Chip ID Register, address 3Eh) the frame will be ignored and the communication failure bit “TF” in the global status byte will be set. Due to this safety functionality, daisy chaining the SPI is not possible. Instead, a parallel operation of the SPI bus by controlling the CSN signal of the connected ICs is recommended.

Serial Data In (SDI)

During the rising edges of SCLK (CSN is low), the data is transferred into the device thru the input pin SDI in a serial way. The device features a stuck-at-one detection, thus upon detection of a command = FFFFFFFh, the device will be forced into the Standby mode. All output drivers are switched off.

Serial Data Out (SDO)

The SDO data output driver is activated by a logical low level at the CSN input and will go from high impedance to a low or high level depending on the global status bit, FLT (Global Error Flag). The first rising edge of the SCLK input after a high to low transition of the CSN pin will transfer the content of the selected register into the data out shift register. Each subsequent falling edge of the SCLK will shift the next bit thru SDO out of the device.

Command Byte / Global Status Byte

Each communication frame starts with a command byte (Table 6). It consists of an operation code (OP[1:0]) which specifies the type of operation (Read, Write, Read & Clear, Readout Device Information) and a six bit address (A[5:0]). If less than six address bits are required, the remaining bits are unused but are reserved. Both Write and Read mode allow access to the internal registers of the device. A “Read & Clear”-access is used to read a status register and subsequently clear its content. The “Read Device Information” allows to read out device related information such as ID-Header, Product Code, Silicon Version and Category and the SPI-frame ID. While receiving the command byte, the global status byte is transmitted to the microcontroller. It contains global fault information for the device.

ID Register

Chip ID Information is stored in five special 8-bit ID. The content can be read out at the beginning of the communication.

Table 6. COMMAND BYTE (IN) / GLOBAL STATUS BYTE (OUT)

Bit	Command Byte (IN) / Global Status Byte (OUT)							
	23	22	21	20	19	18	17	16
NCV7535 IN	OP1	OP0	A5	A4	A3	A2	A1	A0
NCV7535 OUT	FLT	TF	RESB	TSD	-	UOV_OC	-	NRDY
Reset Value	1	0	0	0	0	0	0	1

Table 7. COMMAND BYTE, ACCESS MODE

OP1	OP0	Description
0	0	Write Access (W)
0	1	Read Access (R)
1	0	Read and Clear Access (RC)
1	1	Read Device ID (RDID)

Table 8. COMMAND BYTE, REGISTER ADDRESS

A[5:0]	Access	Description	Content
00h	R/W	Control Register CONTROL_0	Device mode control, external H-Bridge outputs control
10h	R/RC	Status Register STATUS_0	Pre-driver diagnosis
3Fh	R/W	Configuration Register CONFIG	Mask bits for global fault bits, PWM mapping

Table 9. GLOBAL STATUS BYTE CONTENT

FLT	Global Fault Bit	
0	No fault Condition	Failures of the Global Status Byte, bits [6:0] are always linked to the Global Fault Bit FLT. This bit is generated by an OR combination of all failure bits of the device (RESB bit inverted). It is reflected via the SDO pin while CSN is held low and NO clock signal is present (before first positive edge of SCLK). The flag will remain valid as long as CSN is held low. This operation does not cause the Transmission error Flag in the Global Status Byte to be set.
1	Fault Condition	
TF	SPI Transmission Error	
0	No Error	If the number of clock pulses within the previous frame was unequal 0 (FLT polling) or 24. The frame was ignored and this flag was set.
1	Error	
RESB	Reset Bar (Active low)	
0	Reset	Bit is set to "0" after a Power-on-Reset or a stuck-at-1 fault at SI (SPI-input data = FFFFFFFh) has been detected. All outputs are disabled.
1	Normal Operation	
TSD	Over-temperature Shutdown	
0	No Thermal Shutdown	Thermal Shutdown Status indication. In case of a Thermal Shutdown, all output drivers including the charge pump output are deactivated (high impedance). The TSD bit has to be cleared thru a SW reset to reactivate the output drivers and the chargepump output.
1	Thermal Shutdown	
UOV_OC	VS Monitoring, Over-current Status	
0	No Fault	This bit represents a logical OR combination of under-/overvoltage signals (VS) and overcurrent signals.
1	Fault	
NRDY	Not Ready	
0	Device Ready	This bit indicates that the drivers cannot be activated and the chargepump is switched off. After transition from Standby to Active mode, an internal timer is started to allow the internal chargepump to settle before any outputs can be activated. This bit is cleared automatically after the startup is completed.
1	Device Not Ready	

Table 10. CHIP ID INFORMATION

A[5:0]	Access	Description	Content
00h	R	ID header	4300h
01h	R	Version	0100h
02h	R	Product Code 1	7500h
03h	R	Product Code 2	3500h
3Eh	R	SPI Frame ID	0200h

SPI REGISTERS CONTENT

CONTROL_0 Register

Address: 00h

Bit	D15	D14	D13	D12	D11	D10	D9	D8	D7	D6	D5	D4	D3	D2	D1	D0
Access type	-	-	-	-	-	-	RW	RW	RW	RW	-	RW	RW	RW	RW	RW
Bit name	-	-	-	-	-	-	HS1	LS1	HS2	LS2	-	FWH	FWA	OVR	UVR	MODE
Reset value	0	0	0	0	0	0	0	0	0	0	0	0	0	0	0	0

HS/LS Outputs Control	HSx	LSx		Description	Remark
	0	0	default	Gate driver OFF	Activating both HS and LS at the same time is prevented by the internal logic. High-side or low-side freewheeling configuration is performed by FWH and FWA SPI bits
	0	1		LSx enabled	
	1	0		HSx enabled	
	1	1		Gate driver OFF	

Freewheeling High side or low side	FWH		Description	Remark
	0	default	Freewheeling Low side	When FWA=1 and PWM=0, gate high sides are switched OFF and gate low sides are switched ON
	1		Freewheeling High side	When FWA=1 and PWM=0, gate low sides are switched OFF and gate high sides are switched ON

Freewheeling Active or passive	FWA		Description	Remark
	0	default	Passive freewheeling	When PWM=0 and FWH=0, gate high sides are switched OFF. When PWM=0 and FWH=1, gate low sides are switched OFF
	1		Active freewheeling	See FWH remark

Over-voltage Recovery	OVR		Description	Remark
	0	default	Over-voltage Recovery function enabled	If the OVR is disabled by setting OVR=1, the status register STATUS_0 bits VSOV have to be cleared after an OV event.
	1		No Over-voltage Recovery	

Under-voltage Recovery	UVR		Description	Remark
	0	default	Under-voltage Recovery function enabled	If the UVR is disabled by setting UVR=1, the status register STATUS_0 bits VSUV have to be cleared after an UV event.
	1		No Under-voltage Recovery	

Mode Control	MODE		Description	Remark
	0	default	Standby	If MODE is set, the device is switched to Active mode. Resetting MODE forces the device to transition into Standby mode, all internal memory is cleared, all output stages are switched into their default state (off).
	1		Active	

NCV7535

STATUS_0 Register

Address: 10h

Bit	D15	D14	D13	D12	D11	D10	D9	D8	D7	D6	D5	D4	D3	D2	D1	D0
Access type	-	-	-	-	-	-	R/RC	R/RC	R/RC	R/RC	-	-	R/RC	R/RC	-	-
Bit name	-	-	-	-	-	-	OC HS1	OC LS1	OC HS2	OC LS2	-	-	VSUV	VSOV	-	-
Reset value	0	0	0	0	0	0	0	0	0	0	0	0	0	0	0	0

Over-current detection	OCx	Description	Remark
	0	No over-current detected	During an over-current event in one of the HS or LS, the belonging over-current status bit STATUS_0.OCx is set and the dedicated output is switched off. (The global status bit UOV_OC is set, also). To reactivate the output stage again, the microcontroller has to clear the OC failure bit.
1	Over-current detected		

Vs Under-voltage	VSUV	Description	Remark
	0	No under-voltage detected	In case of a Vs under-voltage event, the output stages will be deactivated immediately and the corresponding failure flag will be set and latched. By default (CONTROL_0.UVR cleared) the output stages will be reactivated automatically after Vs is recovered.
1	Under-voltage detected		

Vs Over-voltage	VSOV	Description	Remark
	0	No overvoltage detected	In case of a Vs over-voltage event, the output stages will be deactivated immediately and the corresponding failure flag will be set and latched. By default (CONTROL_0.OVR cleared) the output stages will be reactivated automatically after Vs is recovered.
1	Overvoltage detected		

NCV7535

CONFIG Register

Address: 3Fh

Bit	D15	D14	D13	D12	D11	D10	D9	D8	D7	D6	D5	D4	D3	D2	D1	D0
Access type	RW	RW	RW	RW	RW	RW	RW	RW	RW	RW	RW	RW	RW	-	-	-
Bit name	NOCR LH3	NOCR LH2	NOCR LH1	NOCR LH0	NOCR HL3	NOCR HL2	NOCR HL1	NOCR HL0	OCTH 2	OCTH 1	OCTH 0	HALF HB	SRF	-	-	-
Reset value	0	0	0	0	0	0	0	0	0	0	0	0	0	0	0	0

No-Crossing Timing Configuration	NOCR LH3	NOCR LH2	NOCR LH1	NOCR LH0	Description	Remarks
	0	0	0	0		
0	0	0	0	1	No-crossing limit = 500 ns	
0	0	0	1	0	No-crossing limit = 750 ns	
0	0	0	1	1	No-crossing limit = 1 μ s	
0	1	0	0	0	No-crossing limit = 1.25 μ s	
0	1	0	1	0	No-crossing limit = 1.5 μ s	
0	1	1	1	0	No-crossing limit = 1.75 μ s	
0	1	1	1	1	No-crossing limit = 2 μ s	
1	0	0	0	0	No-crossing limit = 2.25 μ s	
1	0	0	0	1	No-crossing limit = 2.5 μ s	
1	0	0	1	0	No-crossing limit = 2.75 μ s	
1	0	0	1	1	No-crossing limit = 3 μ s	
1	1	0	0	0	No-crossing limit = 3.25 μ s	
1	1	0	0	1	No-crossing limit = 3.5 μ s	
1	1	1	1	0	No-crossing limit = 3.75 μ s	
1	1	1	1	1	No-crossing limit = 4 μ s	

No-Crossing Timing Configuration	NOCR HL3	NOCR HL2	NOCR HL1	NOCR HL0	Description	Remarks
	0	0	0	0		
0	0	0	0	1	No-crossing limit = 500 ns	
0	0	0	1	0	No-crossing limit = 750 ns	
0	0	0	1	1	No-crossing limit = 1 μ s	
0	1	0	0	0	No-crossing limit = 1.25 μ s	
0	1	0	0	1	No-crossing limit = 1.5 μ s	
0	1	1	1	0	No-crossing limit = 1.75 μ s	
0	1	1	1	1	No-crossing limit = 2 μ s	
1	0	0	0	0	No-crossing limit = 2.25 μ s	
1	0	0	0	1	No-crossing limit = 2.5 μ s	
1	0	0	1	0	No-crossing limit = 2.75 μ s	
1	0	0	1	1	No-crossing limit = 3 μ s	
1	1	0	0	0	No-crossing limit = 3.25 μ s	
1	1	0	0	1	No-crossing limit = 3.5 μ s	
1	1	1	1	0	No-crossing limit = 3.75 μ s	
1	1	1	1	1	No-crossing limit = 4 μ s	

NCV7535

Over-Current threshold configuration	OCTH2	OCTH1	OCTH0		Description	Remark
	0	0	0	default	VDS OC limit = 0.25 V	Common setting value for high side & low side
	0	0	1		VDS OC limit = 0.5 V	
	0	1	0		VDS OC limit = 0.75 V	
	0	1	1		VDS OC limit = 1 V	
	1	0	0		VDS OC limit = 1.25 V	
	1	0	1		VDS OC limit = 1.5 V	
	1	1	0		VDS OC limit = 1.75 V	
1	1	1		VDS OC limit = 2 V		

Bridge configuration	HALF HB		Description	Remark
	0	default	Full H-Bridge configuration	See PWM control page 9
	1		2 Half-Bridges configuration	Controlled by SPI only PWM, FWH, FWA are ignored

Slew-Rate configuration	SRF		Description	Remark
	0	default	Slow Slew Rate	Typical Slew Rate of gate driver of 5 V/ μ s
	1		Fast Slew Rate	Typical Slew Rate of gate driver of 30 V/ μ s

MECHANICAL CASE OUTLINE
PACKAGE DIMENSIONS

TSSOP 20
CASE 948AD-01
ISSUE 0

DATE 17 JUL 2008

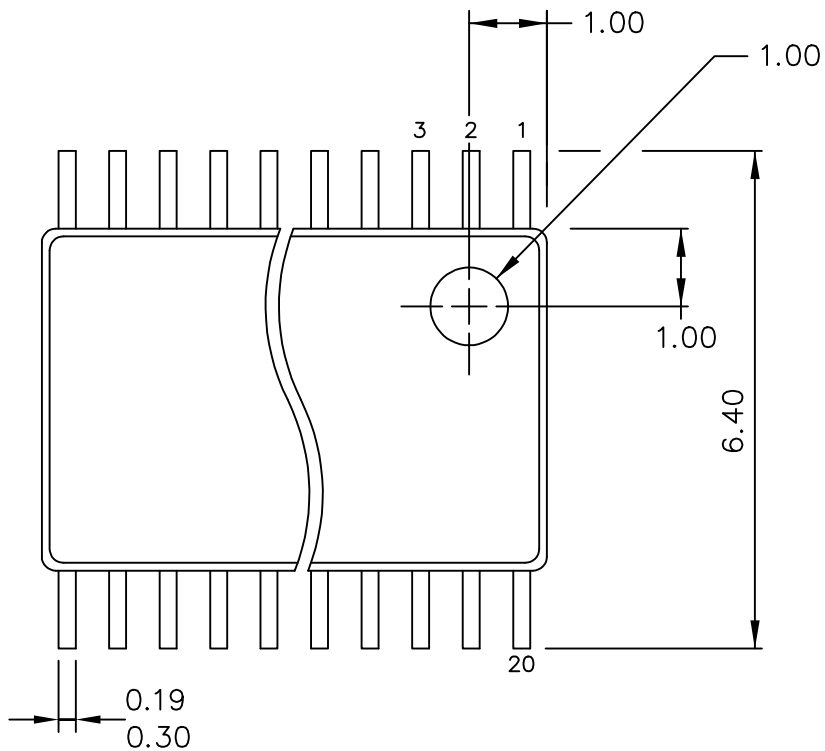

TOP VIEW

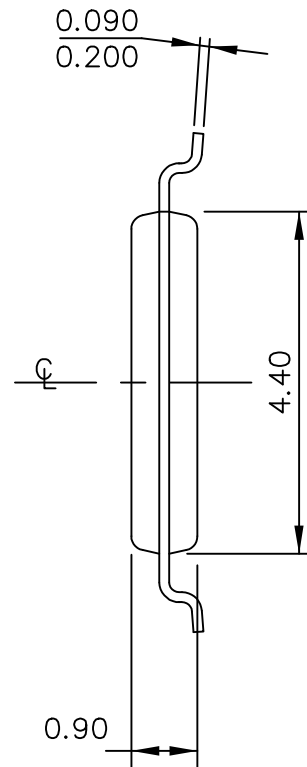

END VIEW

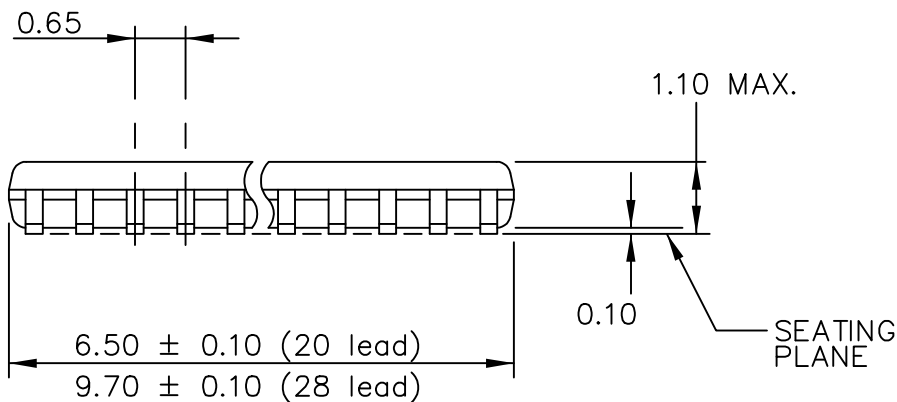

SIDE VIEW

DOCUMENT NUMBER:	98AON31296E	Electronic versions are uncontrolled except when accessed directly from the Document Repository. Printed versions are uncontrolled except when stamped "CONTROLLED COPY" in red.
STATUS:	ON SEMICONDUCTOR STANDARD	
REFERENCE:		
DESCRIPTION:	TSSOP 20	PAGE 1 OF 2

ON Semiconductor and  are trademarks of Semiconductor Components Industries, LLC dba ON Semiconductor or its subsidiaries in the United States and/or other countries. ON Semiconductor owns the rights to a number of patents, trademarks, copyrights, trade secrets, and other intellectual property. A listing of ON Semiconductor's product/patent coverage may be accessed at www.onsemi.com/site/pdf/Patent-Marking.pdf. ON Semiconductor reserves the right to make changes without further notice to any products herein. ON Semiconductor makes no warranty, representation or guarantee regarding the suitability of its products for any particular purpose, nor does ON Semiconductor assume any liability arising out of the application or use of any product or circuit, and specifically disclaims any and all liability, including without limitation special, consequential or incidental damages. Buyer is responsible for its products and applications using ON Semiconductor products, including compliance with all laws, regulations and safety requirements or standards, regardless of any support or applications information provided by ON Semiconductor. "Typical" parameters which may be provided in ON Semiconductor data sheets and/or specifications can and do vary in different applications and actual performance may vary over time. All operating parameters, including "Typicals" must be validated for each customer application by customer's technical experts. ON Semiconductor does not convey any license under its patent rights nor the rights of others. ON Semiconductor products are not designed, intended, or authorized for use as a critical component in life support systems or any FDA Class 3 medical devices or medical devices with a same or similar classification in a foreign jurisdiction or any devices intended for implantation in the human body. Should Buyer purchase or use ON Semiconductor products for any such unintended or unauthorized application, Buyer shall indemnify and hold ON Semiconductor and its officers, employees, subsidiaries, affiliates, and distributors harmless against all claims, costs, damages, and expenses, and reasonable attorney fees arising out of, directly or indirectly, any claim of personal injury or death associated with such unintended or unauthorized use, even if such claim alleges that ON Semiconductor was negligent regarding the design or manufacture of the part. ON Semiconductor is an Equal Opportunity/Affirmative Action Employer. This literature is subject to all applicable copyright laws and is not for resale in any manner.

PUBLICATION ORDERING INFORMATION

LITERATURE FULFILLMENT:

Email Requests to: orderlit@onsemi.com

ON Semiconductor Website: www.onsemi.com

TECHNICAL SUPPORT

North American Technical Support:
Voice Mail: 1 800-282-9855 Toll Free USA/Canada
Phone: 011 421 33 790 2910

Europe, Middle East and Africa Technical Support:

Phone: 00421 33 790 2910

For additional information, please contact your local Sales Representative