

# BMF80N250C1

## Super Junction Power MOSFET

800V, 18A, 250mΩ

### Description

BMF80N250C1 is power MOSFET using bestirpower's advanced super junction technology that can realize very low on-resistance and gate charge. It will provide much high efficiency by using optimized charge coupling technology. These user friendly devices give an advantage of Low EMI to designers as well as low switching loss.

### Applications

- PC power
- Telecom / Server power supply
- LED lighting
- EV charger
- Solar / UPS

### Features

$V_{DS}@T_{J,max}$	$I_D$	$R_{DS(on),max}$	$Q_{g,typ}$
850V	18 A	250 mΩ	27nC

- Ultra-fast body diode
- Extremely low losses due to very low FOM
- Very high commutation ruggedness
- Halogen Free, and RoHS Compliant

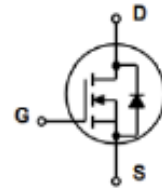
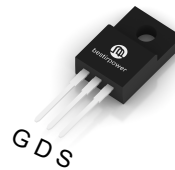

### Absolute Maximum Ratings ( $T_C = 25^\circ\text{C}$ unless otherwise noted)

Symbol	Parameter	Value	Unit
$V_{DSS}$	Drain to Source Voltage <sup>1)</sup>	800	V
$V_{GSS}$	Gate to Source Voltage	$\pm 30$	V
$I_D$	Drain Current <sup>2)</sup>	$V_{GS} = 10\text{V}, (T_C = 25^\circ\text{C})$	18
		$V_{GS} = 10\text{V}, (T_C = 100^\circ\text{C})$	11
$I_{DM}$	Drain Current	Pulsed	54
$E_{AS}$	Single Pulsed Avalanche Energy <sup>3)</sup>	650	mJ
$I_{AR}$	Repetitive Avalanche Energy	5.1	A
dv/dt	MOSFET dv/dt ruggedness	50	V/ns
	Diode Recovery dv/dt ruggedness <sup>4)</sup>	50	
$P_D$	Power Dissipation ( $T_C = 25^\circ\text{C}$ )	34	W
$T_J, T_{STG}$	Storage Temperature Range	-55 to 150	$^\circ\text{C}$
$T_L$	Maximum Lead Temperature for Soldering, 1/8" from Case for 10 Seconds	260	$^\circ\text{C}$

### Thermal Characteristics

Symbol	Parameter	Value	Unit
$R_{\theta C}$	Thermal Resistance, Junction to Case, Max.	3.67	$^\circ\text{C/W}$
$R_{\theta A}$	Thermal Resistance, Junction to Ambient, Max. *minimal footprint	62.5	

1) Limited by  $T_j$  max. Maximum duty cycle  $D=0.75$ .

2) Pulse width  $t_p$  limited by  $T_j, max$ .

3)  $V_{DD}=50\text{V}$ ,  $R_G=25\Omega$ , Starting  $T_j=25^\circ\text{C}$ .

4)  $V_{DClink}=400\text{V}$ ;  $V_{DS,peak} < V_{(BR)DSS}$ ; identical low side and high side switch with identical  $R_G$ .

**Electrical Characteristics** ( $T_J = 25^\circ\text{C}$  unless otherwise noted)

Symbol	Parameter	Test Conditions	Min	Typ	Max	Unit
<b>Off Characteristics</b>						
$BV_{DSS}$	Drain to Source Breakdown Voltage	$V_{GS} = 0V, I_D = 250\mu A$	800	-	-	V
$I_{DSS}$	Zero Gate Voltage Drain Current	$V_{DS} = 800V, V_{GS} = 0V, T_J = 25^\circ\text{C}$	-	-	10	$\mu A$
$I_{GSS}$	Gate-Source Leakage Current	$V_{GS} = \pm 30V, V_{DS} = 0V$	-	-	$\pm 100$	nA

**On Characteristics**

$V_{GS(th)}$	Gate Threshold Voltage	$V_{GS} = V_{DS}, I_D = 250\mu A$	2.0	3.0	4.0	V
$R_{DS(on)}$	Static Drain to Source On Resistance	$V_{GS} = 10V, I_D = 8.5A, T_J = 25^\circ\text{C}$	-	220	250	mΩ

**Dynamic Characteristics**

$C_{iss}$	Input Capacitance	$V_{GS} = 0V, V_{DS} = 100V, f = 250\text{KHz}$	-	1510	-	pF
$C_{oss}$	Output Capacitance		-	58	-	pF
$C_{rss}$	Reverse Transfer Capacitance		-	2	-	pF
$Q_g$	Total Gate Charge	$V_{GS} = 0-10V,$ $V_{DD} = 400V, I_D = 9A$	-	27	-	nC
$Q_{gs}$	Gate to Source Charge		-	5.5	-	nC
$Q_{gd}$	Gate to Drain "Miller" Charge		-	8	-	nC
$V_{plateau}$	Gate plateau voltage		-	3.8	-	V
$R_G$	Gate Resistance	$f = 1.0\text{MHz}$ open drain	-	15	-	Ω

**Switching Characteristics**

$t_{d(on)}$	Turn-On Delay Time	$V_{GS} = 10V, V_{DD} = 400V, I_D = 9A$	-	13	-	ns
$t_r$	Turn-On Rise Time		-	2	-	ns
$t_{d(off)}$	Turn-Off Delay Time		-	80	-	ns
$t_f$	Turn-Off Fall Time		-	7	-	ns

**Reverse Diode Characteristics**

$I_{SD}$	Continuous Diode Forward Current		-	-	18	A
$V_{SD}$	Diode Forward Voltage	$I_F = 8.5A, V_{GS} = 0V, T_J = 25^\circ\text{C}$	-	0.8	-	V
$t_{rr}$	Reverse Recovery Time	$V_R = 400V, I_F = 9A,$ $di_F/dt = 100A/\mu s$	-	255	-	ns
$Q_{rr}$	Reverse Recovery Charge		-	3.1	-	$\mu C$
$I_{rm}$	Reverse Recovery Current		-	20	-	A

**Figure 1. Power dissipation**

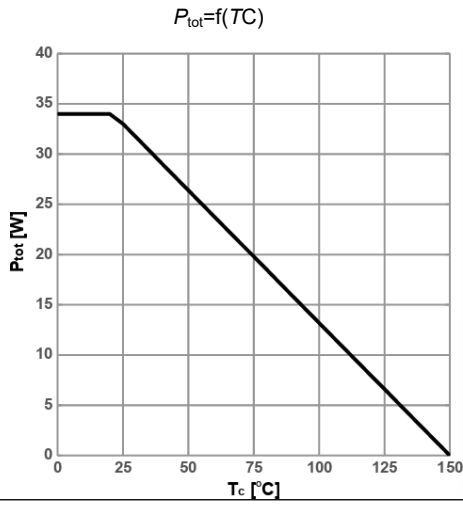

**Figure 2. Max. transient thermal impedance**

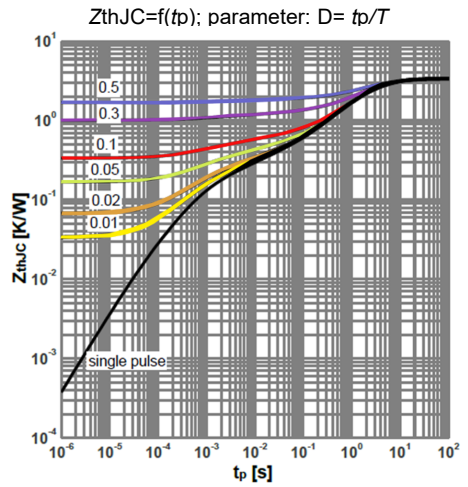

**Figure 3: Safe operating area**

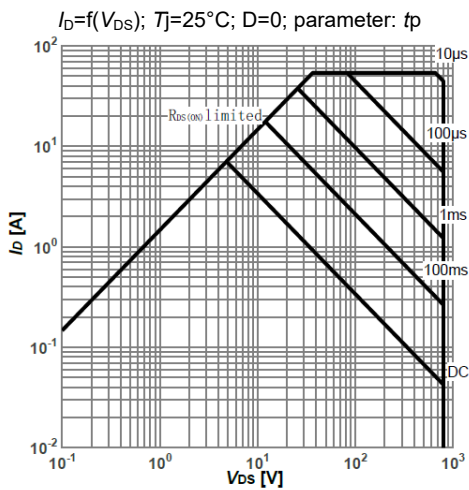

**Figure 4: Typ. output characteristics**

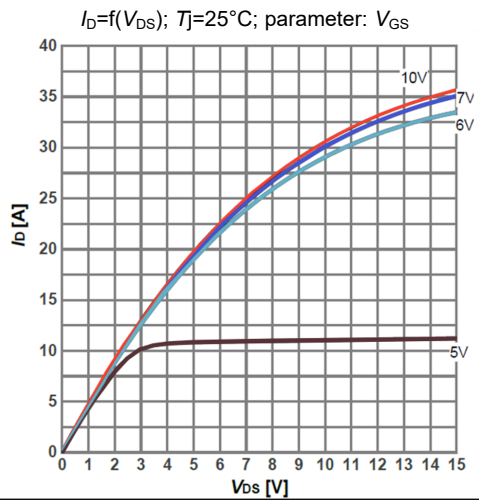

**Figure 5:Typ. output characteristics**

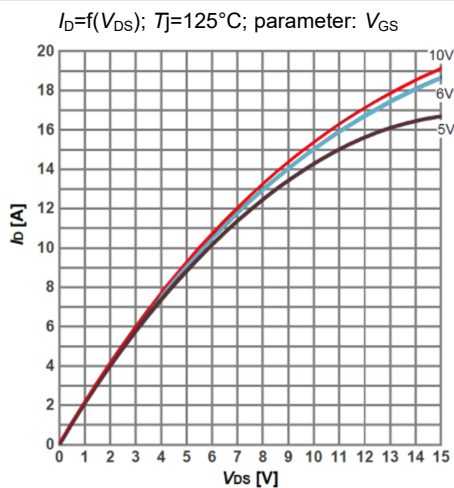

**Figure 6: Typ. drain-source on-state resistance**

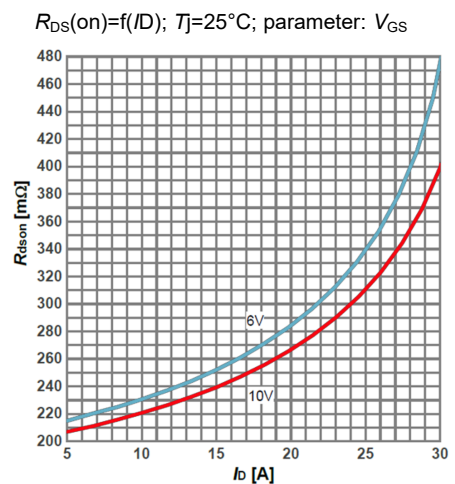

**Figure 7: drain-source on-state resistance**

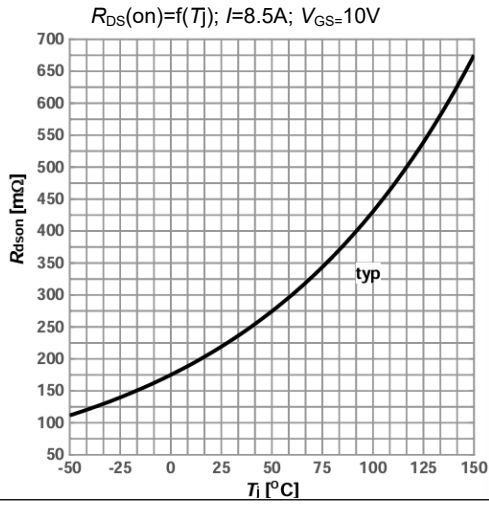

**Figure 8: Typ. transfer characteristics**

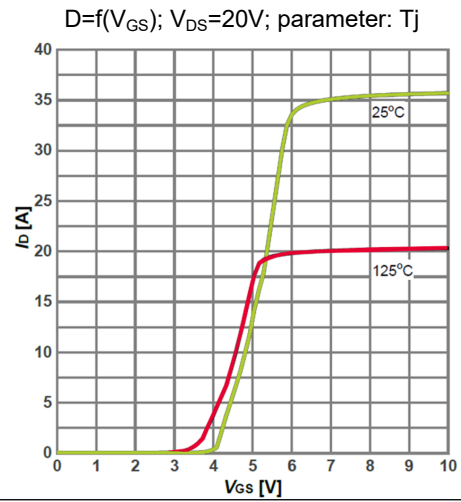

**Figure 9:Typ. gate charge**

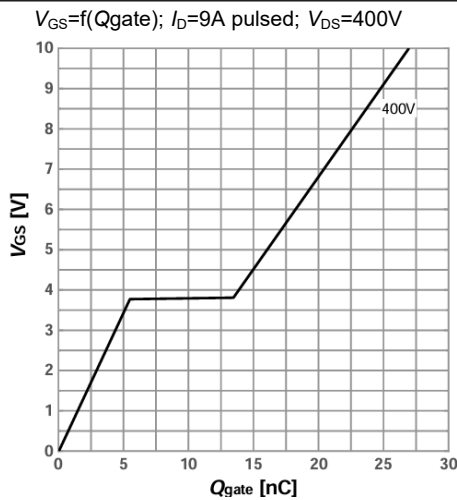

**Figure10:Forward characteristics of reverse diode**

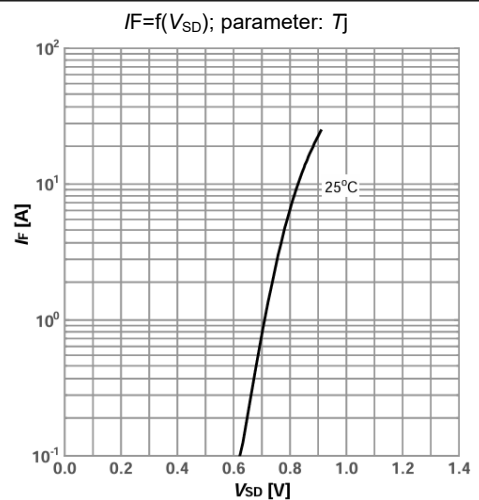

**Figure11:Drain-source breakdown voltage**

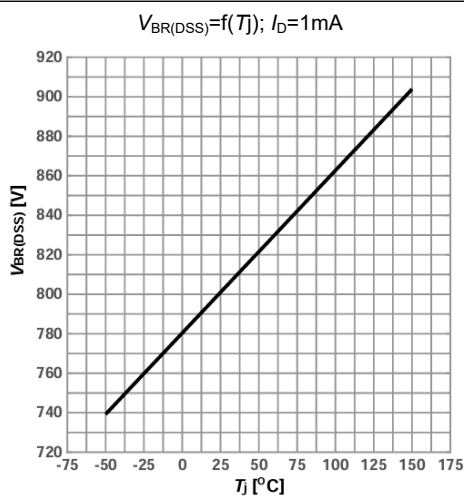

**Figure12:Maximum Drain Current**

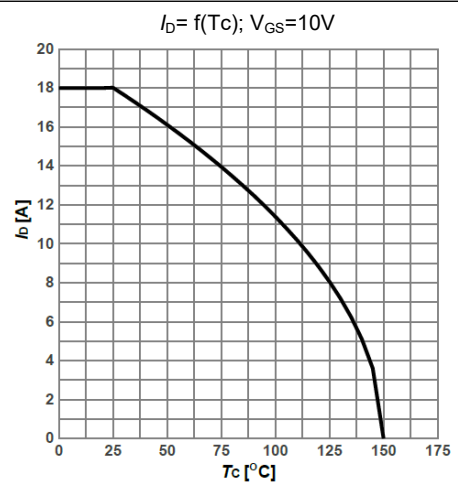

**Figure13:Typ. capacitances**

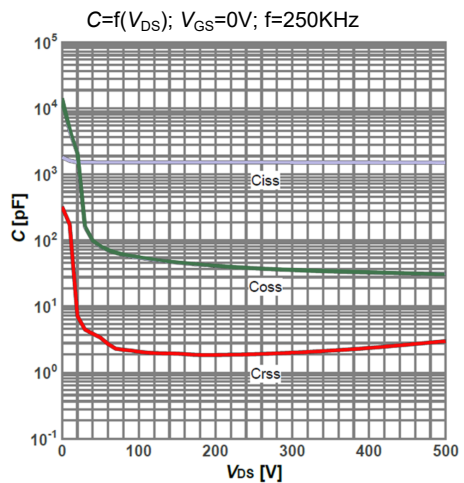

**Figure14:Typ. Coss stored energy**

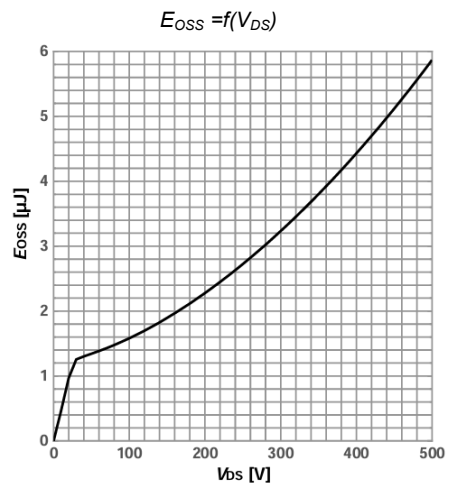

### Test Circuits

**Figure15:Diode Characteristics**

Test circuit for diode characteristics and Diode recovery waveform

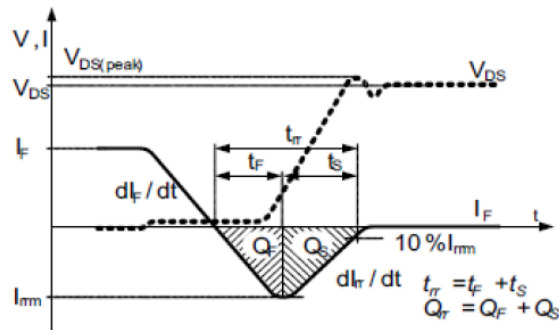
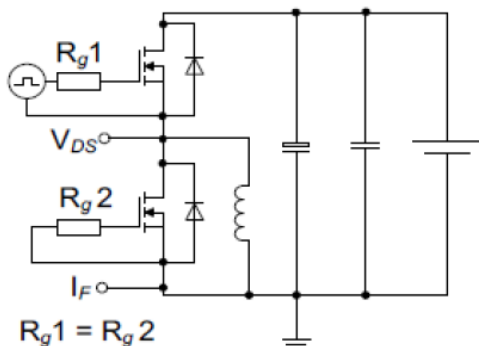

**Figure16:Switching Times**

Switching times test circuit for inductive load and Switching times waveform

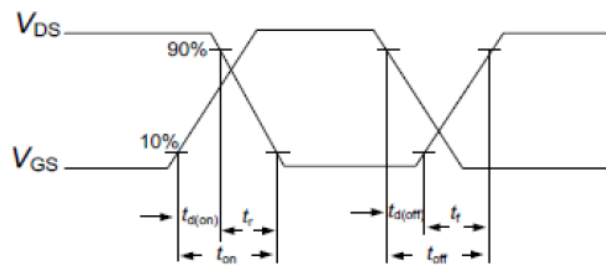
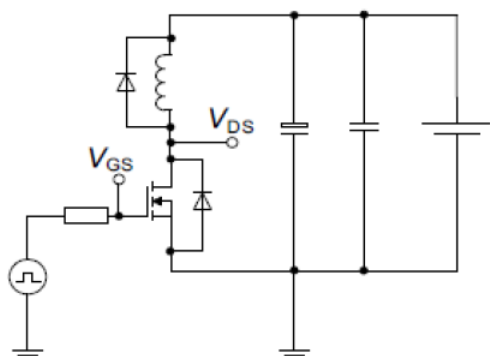

**Figure17:Unclamped Inductive Load**

Unclamped inductive load test circuit and Unclamped inductive waveform

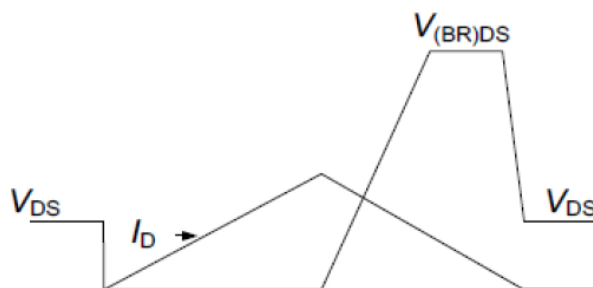
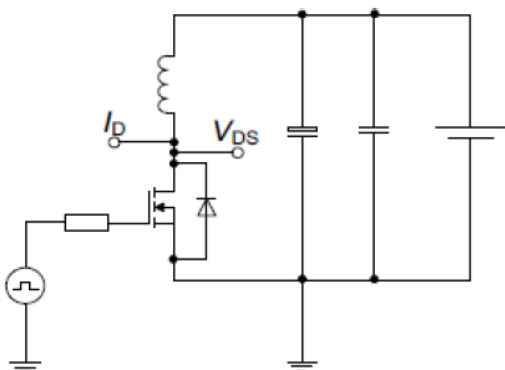

**Package Outlines**

**TO-220F**

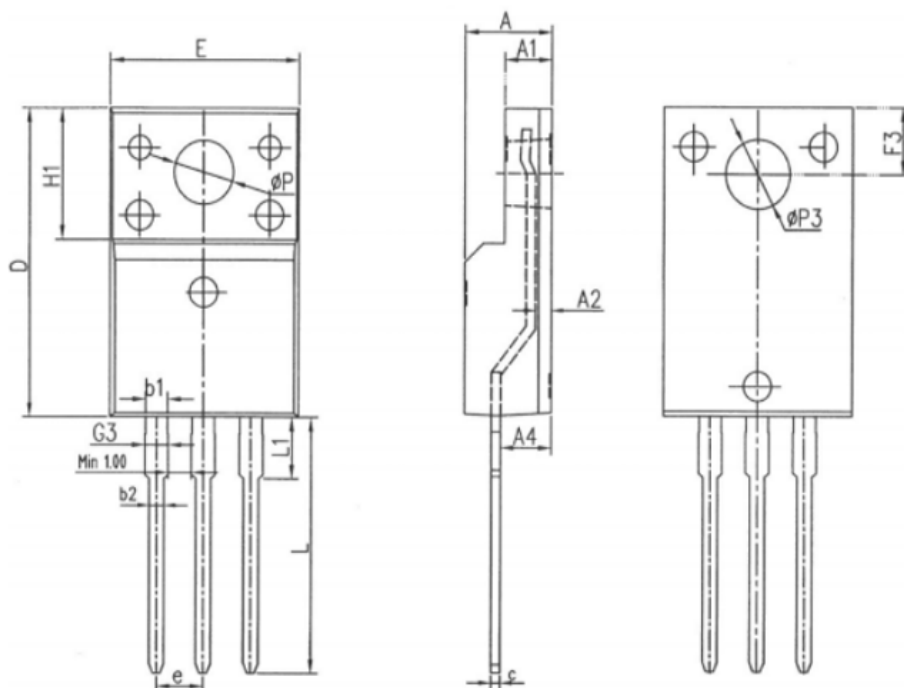

SYMBOL	MM		
	MIN	NOM	MAX
E	10.00	10.20	10.40
A	4.50	4.70	4.90
A1	2.34	2.54	2.74
A2	0.65	0.85	1.30
A4	2.55	2.75	2.95
c	0.40	0.50	0.65
D	15.57	15.87	16.17
H1	6.70REF		
e	2.54BSC		
$\Phi P$	3.183REF		
L	12.68	12.98	13.28
L1	3.25	3.45	3.65
$\Phi P3$	3.45REF		
F3	3.10	3.30	3.50
G3	1.10	1.30	1.50
b1	1.05	1.20	1.35
b2	0.70	0.80	0.92

\* Dimensions in millimeters

## Package Marking and Ordering Information

Part Number	Top Marking	Package	Packing Method	Quantity
BMF80N250C1	BMF80N250C1	TO220F	Tube	50 units

## Disclaimer

Bestirpower reserve the right to make changes, corrections, enhancements, modifications, and improvements to Bestirpower products and/or to this document at any time without notice.

The information given in this document shall in no event be regarded as a guarantee of conditions or characteristics. Bestirpower does not assume any liability for infringement of patents, copyrights, or other intellectual property rights of third parties by or arising from the use of Products or technical information described in this document.

This document is the property of Bestirpower Co., LTD., and not allowed to copy or transformed to other format if not under the authority approval.

© 2023 Bestirpower – All rights reserved