

BCD65N190Y1

N-Channel Silicon Carbide Power MOSFET

650 V, 19A, 190 mΩ



bestirpower

Features

- Revolutionary semiconductor material Silicon Carbide
- High blocking voltage with low on-resistance
- High-speed switching with very low switching losses
- High-speed and high robust intrinsic body diode

$BV_{DSS, T_C=25^\circ C}$	$I_D, T_C=25^\circ C$	$R_{DS(on), typ}$	$Q_{g, typ}$
650 V	19A	190 mΩ	15.3nC

Applications

- LED driver
- PD charger
- PC adapter
- Air-conditioning
- E-bike charger

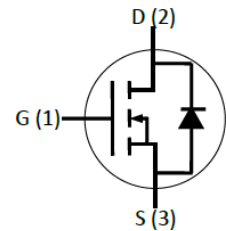
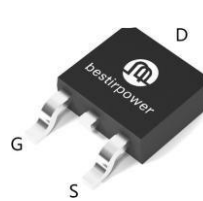

Absolute Maximum Ratings ($T_J = 25^\circ C$ unless otherwise noted)

Symbol	Parameter	Value	Unit	
V_{DSS}	Drain to Source Voltage	650	V	
V_{GS}	Gate to Source Voltage (DC)	-10/22	V	
V_{GSop}	Recommended Operation Value	0/15	V	
I_D	Drain Current	$V_{GS} = 15 V, (T_C = 25^\circ C)$	19	A
		$V_{GS} = 15 V, (T_C = 100^\circ C)$	13.5	
I_{DM}	Drain Current	Pulsed	33	A
P_D	Power Dissipation	$(T_C = 25^\circ C)$	76	W
		Derate Above $25^\circ C$	0.51	W/°C
T_J, T_{STG}	Operating and Storage Temperature Range	-55 to 175	°C	

Thermal Characteristics

Symbol	Parameter	Value	Unit
R_{thj-C}	MOSFET/Body Diode Junction-Case Thermal Resistance	1.98	°C/W
T_{sold}	Soldering temperature, wave soldering only allowed at leads	260	°C

Electrical Characteristics ($T_J = 25^\circ\text{C}$ unless otherwise noted)

Symbol	Parameter	Test Conditions	Min	Typ	Max	Unit
--------	-----------	-----------------	-----	-----	-----	------

Off Characteristics

BV_{DSS}	Drain to Source Breakdown Voltage	$I_D = 100\mu\text{A}$	650	-	-	V
I_{DSS}	Zero Gate Voltage Drain Current	$V_{DS} = 650\text{ V}, V_{GS} = 0\text{ V}$	-	0.1	20	μA
I_{GSS}	Gate-Source Leakage Current	$V_{DS} = 0\text{ V}, V_{GS} = +22\text{ V}$	-	-	+250	nA
I_{SGS}	Source-Gate Leakage Current	$V_{DS} = 0\text{ V}, V_{GS} = -10\text{ V}$	-	-	+250	nA

On Characteristics

$V_{GS(th)}$	Gate Threshold Voltage	$V_{GS} = V_{DS}, I_D = 10\text{ mA}, T_J = 25^\circ\text{C}$	-	3.9	-	V
$R_{DS(on)}$	Static Drain to Source On Resistance	$V_{GS} = 15\text{ V}, I_D = 7\text{ A}, T_J = 25^\circ\text{C}$	-	187	215	mΩ
		$V_{GS} = 15\text{ V}, I_D = 7\text{ A}, T_J = 175^\circ\text{C}$	-	175	-	

Dynamic Characteristics

C_{iss}	Input Capacitance	$V_{GS} = 0\text{ V}, V_{DS} = 650\text{ V}, f = 1\text{ MHz}$	-	431	-	pF
C_{oss}	Output Capacitance		-	30	-	
C_{riss}	Reverse Capacitance		-	3	-	
$Q_{g(tot)}$	Total Gate Charge	$V_{DS} = 400\text{ V}, I_D = 7\text{ A}, V_{GS} = 0\text{ V} / 15\text{ V}$	-	15.3	-	nC
Q_{gs}	Gate to Source Charge		-	5.5	-	
Q_{gd}	Gate to Drain "Miller" Charge		-	2.6	-	
R_G	Internal Gate Resistance	$f = 1\text{ MHz}, V_{AC} = 25\text{ mV}$	-	36	-	Ω

Switching Characteristics

$t_{d(on)}$	Turn-On Delay Time	$V_{GS} = 0/15\text{ V}, L = 600\mu\text{H}$ $V_{DS} = 400\text{ V}, I_D = 7\text{ A},$ $R_{G(on)} = 2.2\Omega, R_{G(off)} = 2.2\Omega$	-	29.2	-	ns
t_r	Turn-On Rise Time		-	11.7	-	
$t_{d(off)}$	Turn-Off Delay Time		-	46.1	-	
t_f	Turn-Off Fall Time		-	16.5	-	
E_{on}	Turn-On Switching Energy		-	67.8	-	μJ
E_{off}	Turn-Off Switching Energy		-	15	-	

Source-Drain Diode Characteristics

V_{SD}	Body Diode Forward Voltage	$V_{GS} = 0\text{ V}, I_{SD} = 3.5\text{ A}, T_C = 25^\circ\text{C}$	-	3.3	-	V
		$V_{GS} = 0\text{ V}, I_{SD} = 3.5\text{ A}, T_C = 175^\circ\text{C}$	-	2.8	-	V
t_{rr}	Reverse Recovery Time	$V_{DS} = 400\text{ V}, V_{GS} = 0\text{ V}, I_{SD} = 7\text{ A},$ $di/dt = 1.2\text{ kA}/\mu\text{s}$	-	26	-	ns
Q_{rr}	Reverse Recovery Charge		-	68	-	nC
I_{rrm}	Peak Reverse Recovery Current		-	6.9	-	A

Typical Performance Characteristics

Figure 1. Safe operating area (SOA)

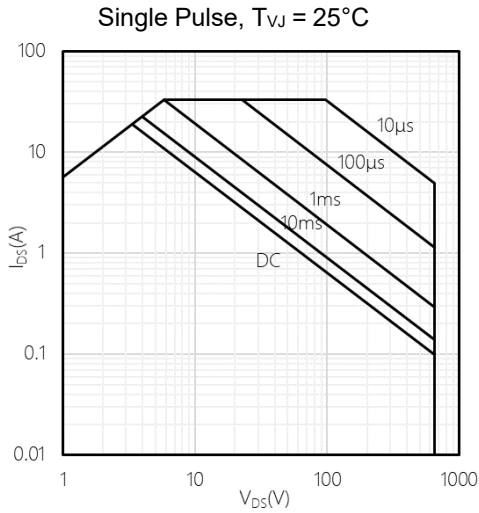

Figure 2. Power dissipation as a function of case temperature limited by bond wire

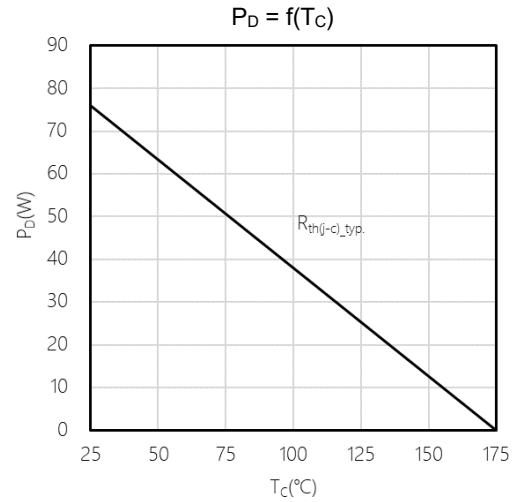

Figure 3. Typical output characteristic, VGS as parameter

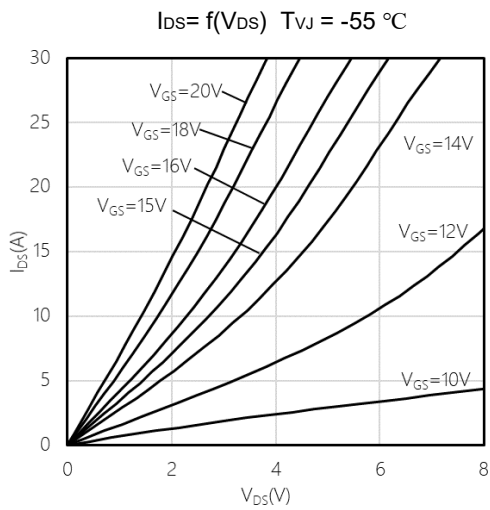

Figure 4. Typical output characteristic, VGS as parameter

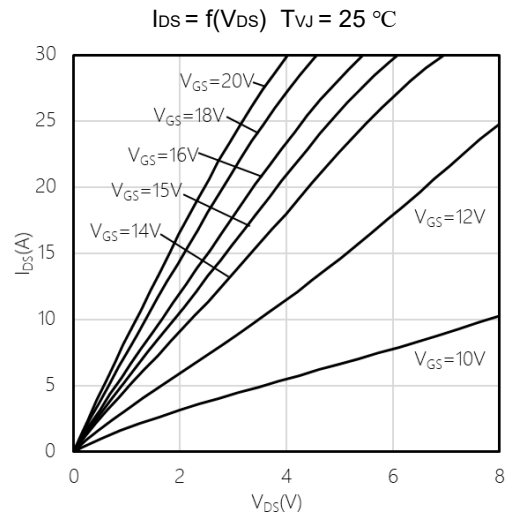

Figure 5. Typical output characteristic, VGS as parameter

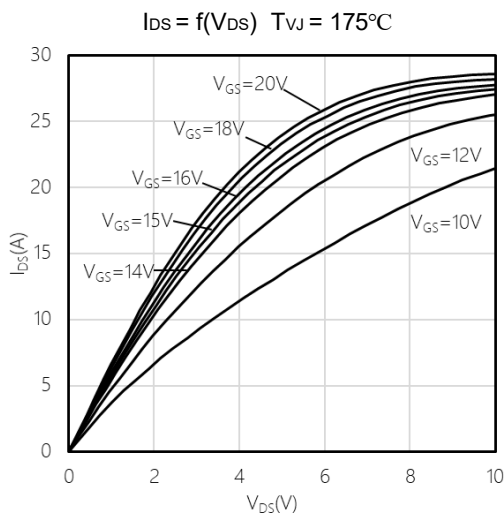
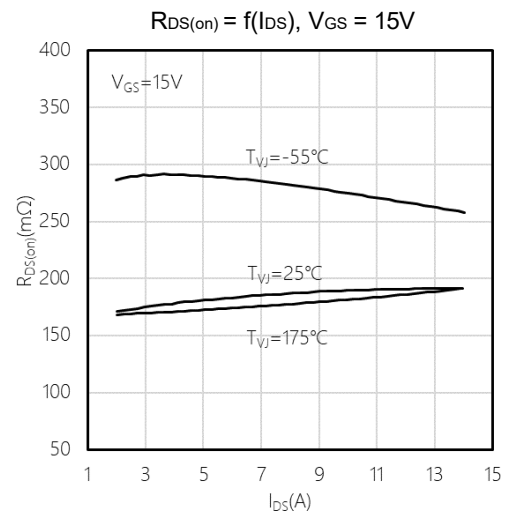

Figure 6. Typical on-state resistance as a function of drain current



Typical Performance Characteristics

Figure 7. Typical on-state resistance as a function of temperature

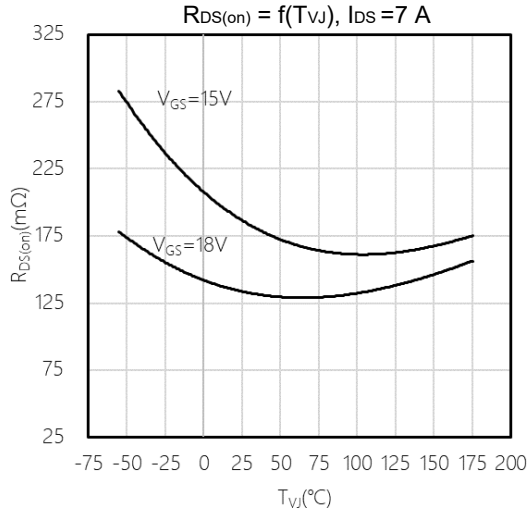

Figure 8. Typical on-state resistance as a function of V_{GS}

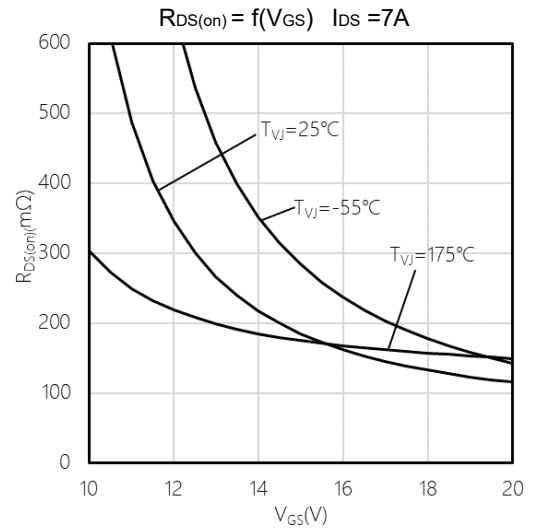

Figure 9. Typical transfer characteristic

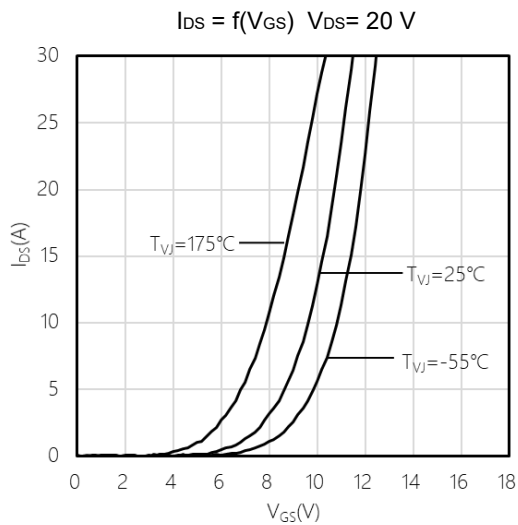

Figure 10. Typical gate-source threshold voltage as a function of junction temperature

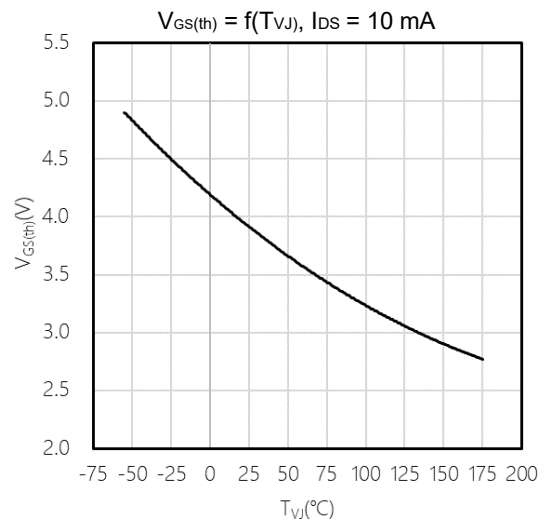

Figure 11. Typical reverse drain current as function of reverse drain voltage, V_{GS} as parameter

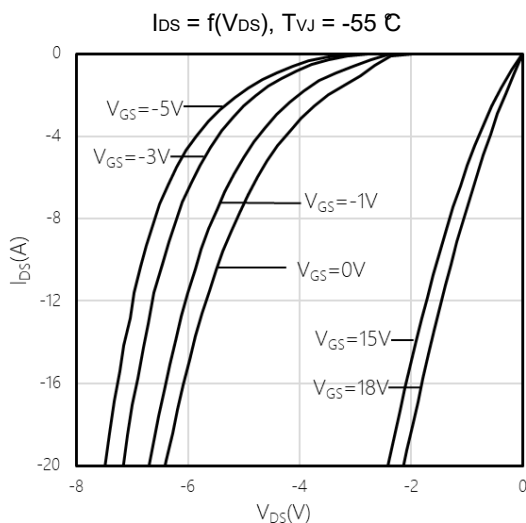
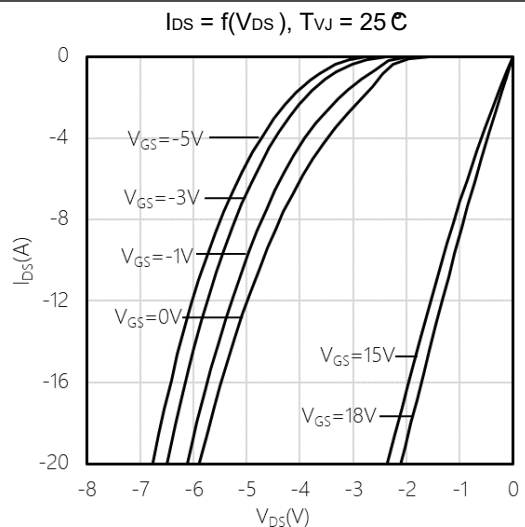

Figure 12. Typical reverse drain current as function of reverse drain voltage, V_{GS} as parameter



Typical Performance Characteristics

Figure 13. Typical reverse drain current as function of reverse drain voltage, VGS as parameter

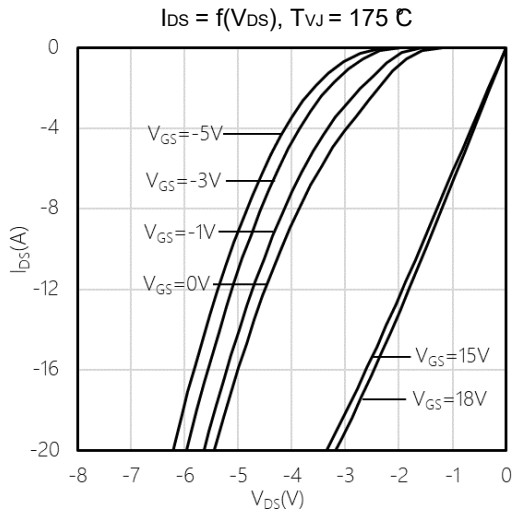

Figure 14. Typical reverse drain voltage as function of junction temperature

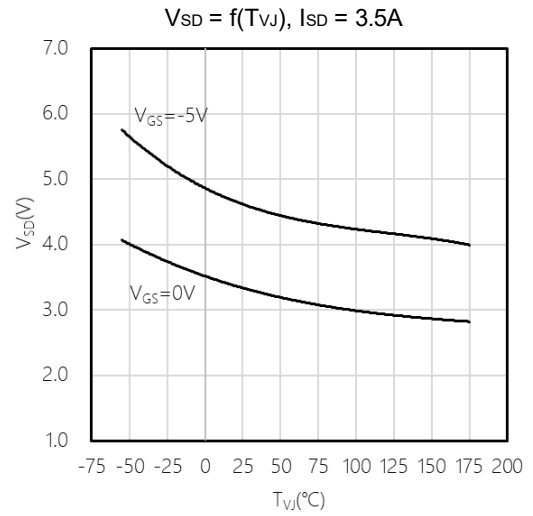

Figure 15. Typical switching energy as a function of junction temperature

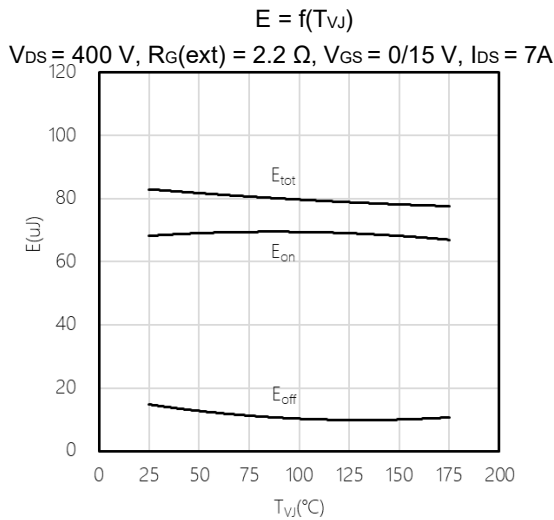

Figure 16. Typical switching energy losses as a function of gate resistance

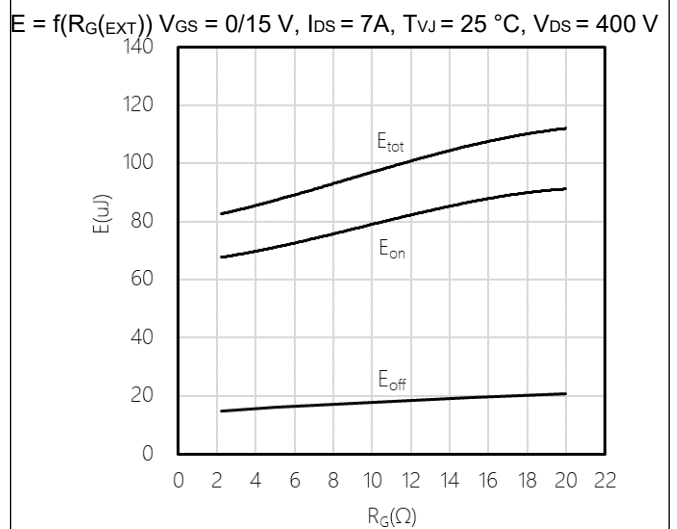

Figure 17. Typical switching energy losses as a function of gate resistance

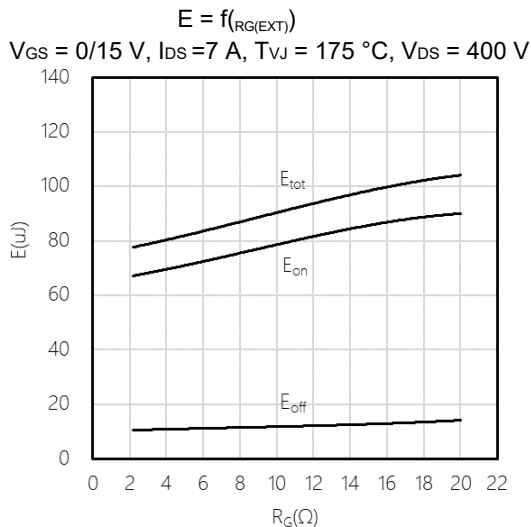
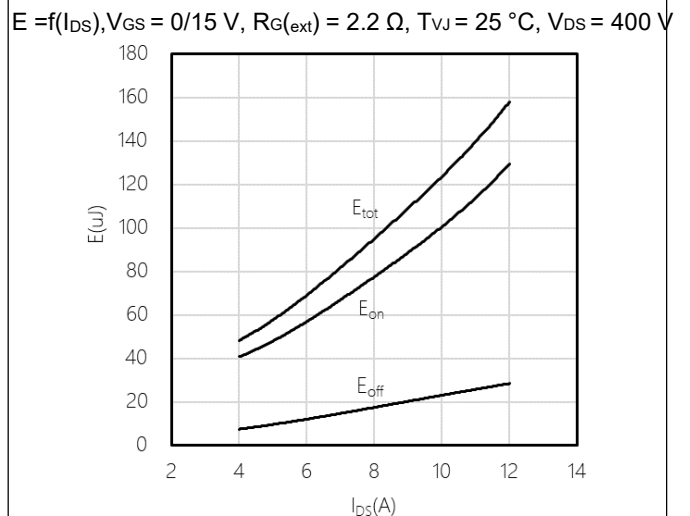

Figure 18. Typical switching energy losses as a function of I_DS



Typical Performance Characteristics

Figure 19. Typical switching energy losses as a function of I_{DS}

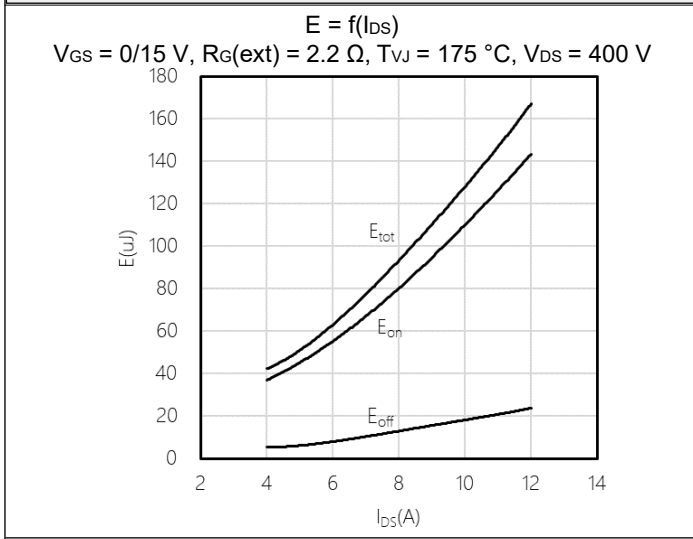

Figure 20. Typical switching energy losses as a function of V_{DS}

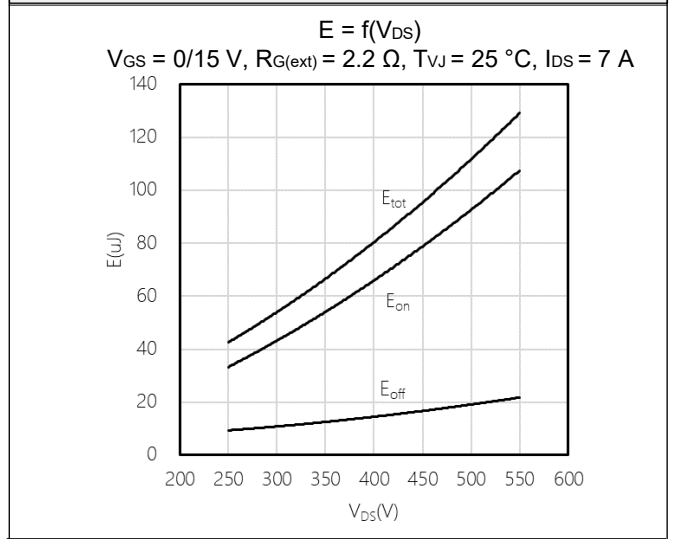

Figure 21. Typical switching energy losses as a function of V_{DS}

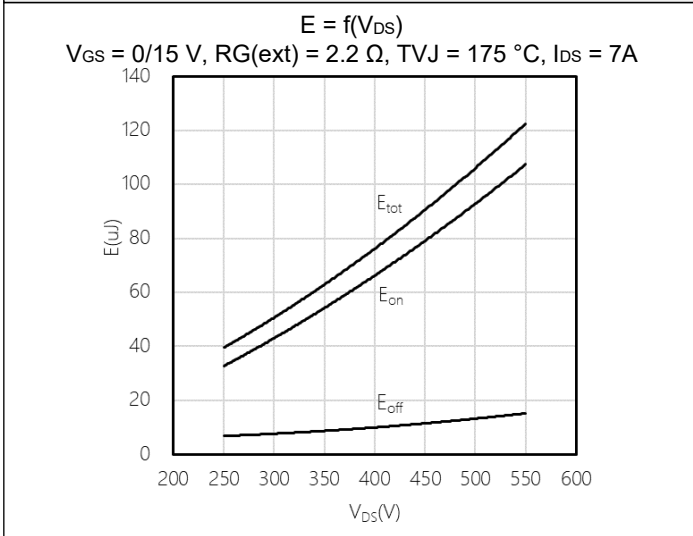

Figure 22. Typical gate charge

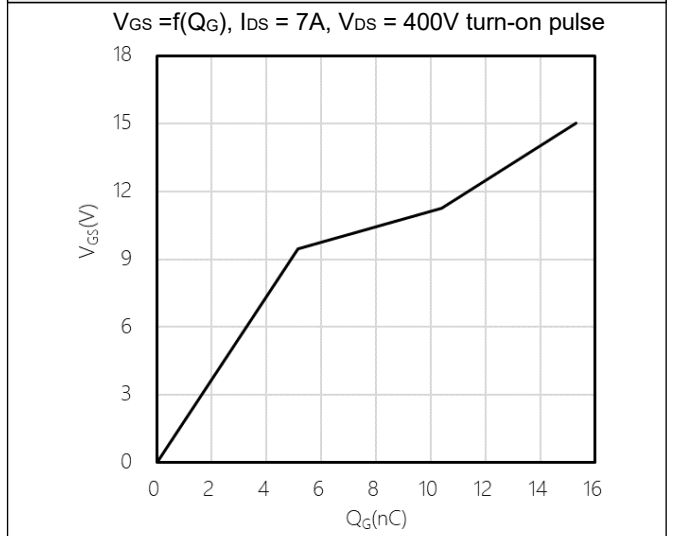

Figure 23. Typical capacitance as a function of drain-source voltage

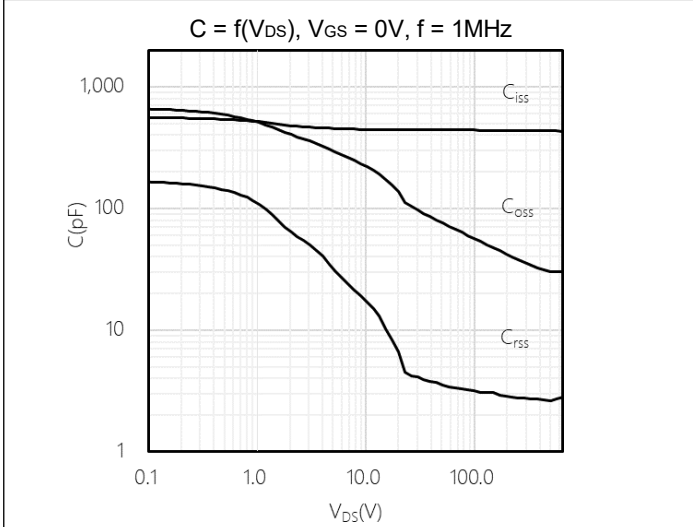
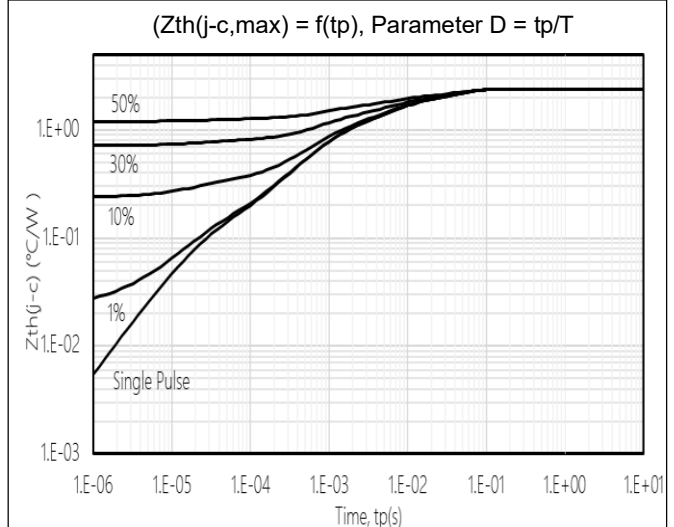
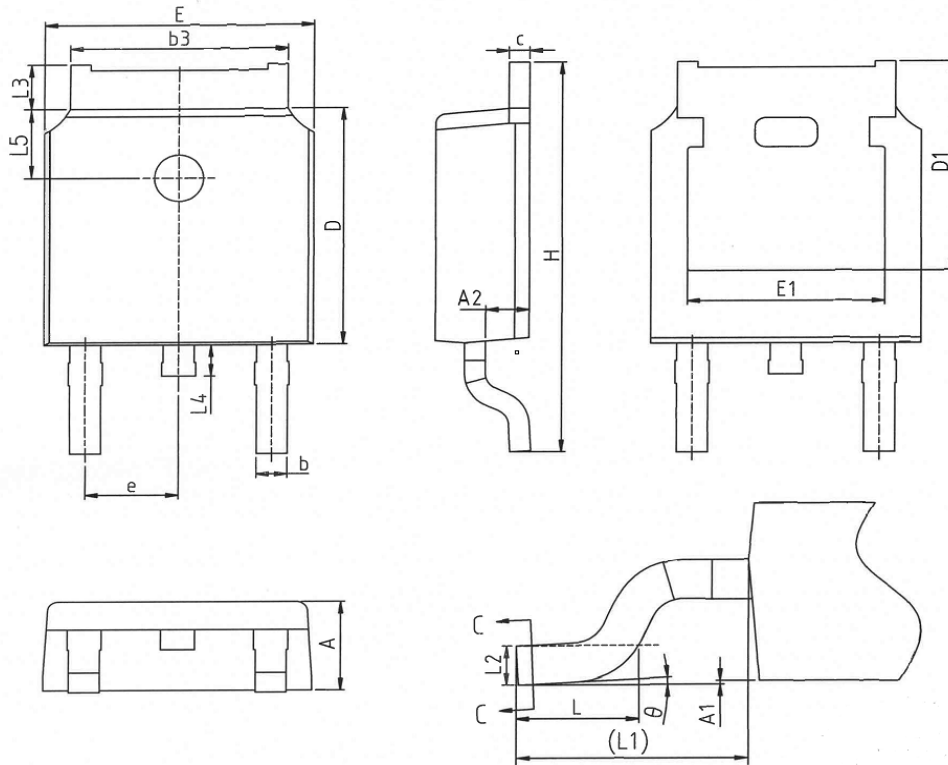

Figure 24. Transient thermal resistance (MOSFET)



Package Outlines

D-Pak



COMMON DIMENSIONS

SYMBOL	mm		
	MIN	NOM	MAX
A	2.20	2.30	2.38
A1	0.00	-	0.12
A2	0.97	1.07	1.17
b	0.68	0.78	0.90
b3	5.20	5.33	5.46
c	0.43	0.53	0.61
D	5.98	6.10	6.22
D1	5.30REF		
E	6.40	6.60	6.73
E1	4.63	-	-
e	2.286BSC		
H	9.40	10.10	10.50
L	1.38	1.50	1.75
L1	2.90REF		
L2	0.51BSC		
L3	0.88	-	1.28
L4	0.50	-	1.00
L5	1.65	1.80	1.95
θ	0°	-	8°

* Dimensions in millimeters

Package Marking and Ordering Information

Part Number	Top Marking	Package	Packing Method	Quantity
BCD65N180Y1	BCD65N180Y1	DPAK	Tape & Reel	2500 units

Disclaimer

Bestirpower reserve the right to make changes, corrections, enhancements, modifications, and improvements to Bestirpower products and/or to this document at any time without notice.

The information given in this document shall in no event be regarded as a guarantee of conditions or characteristics. Bestirpower does not assume any liability for infringement of patents, copyrights, or other intellectual property rights of third parties by or arising from the use of Products or technical information described in this document.

This document is the property of Bestirpower Co., LTD., and not allowed to copy or transformed to other format if not under the authority approval.

© 2025 Bestirpower – All rights reserved