

LISTEN.
THINK.
SOLVE.®

PowerFlex® 700



TECHNICAL DATA

ADJUSTABLE FREQUENCY AC DRIVES

Product Overview

The PowerFlex 700 AC drive offers outstanding performance in an easy-to-use drive that you have come to expect from Rockwell Automation. This world-class performance comes in a small and competitively priced package. The PowerFlex 700 AC drive is designed to control three-phase induction motors in applications with requirements ranging from the simplest speed control to the most demanding torque control. The drive has volts per hertz, sensorless vector and vector control. Vector control includes Allen-Bradley's patented Force™ Technology which provides world class motor control.



Table of Contents

Description	Page
Standard Drives Program	3
Catalog Number Explanation	5
Factory Installed Options	7
User Installed Options	8
Installation Considerations	17
Cable Recommendations	29
Power Ratings and Branch Circuit Protection	30
Maximum Motor Cable Lengths	37
Mounting	43
PowerFlex 700 Frames	44
Approximate Dimensions	45
PowerFlex 700 Configured Drives	62
Specifications	64
Derating Guidelines	68

Reference Materials

For additional PowerFlex 700 data and general drive information, refer to the following publications:

Title	Publication	Available Online at...
PowerFlex 700 User Manual	20B-UM002...	www.rockwellautomation.com/literature
PowerFlex 700 Installation Instructions, Frames 7-10	20B-IN014...	
PowerFlex Reference Manual	PFLEX-RM004...	
Wiring and Grounding Guidelines for PWM AC Drives	DRIVES-IN001...	
Preventive Maintenance of Industrial Control and Drive System Equipment	DRIVES-TD001...	
Safety Guidelines for the Application, Installation and Maintenance of Solid State Control	SGI-1.1	

For other information, contact Allen-Bradley Drives Technical Support:

Title	Online at...
Allen-Bradley Drives Technical Support	www.ab.com/support/abdrives

Standard Drives Program

Flexible Packaging and Mounting

- **IP20, NEMA/UL Type 1** – For conventional mounting inside or outside a control cabinet. Conduit plate is removable for easy installation and replacement without disturbing conduit.
- **IP54, NEMA/UL Type 12** – Stand-alone, wall mount drives are available for dust tight applications with power ratings from 75 to 200 HP (Frames 5 & 6).
- **IP54, NEMA/UL Type 12** – Flange mount drives with an IP00, NEMA/UL Type Open front. These can be installed in a user supplied cabinet to meet IP54, NEMA/UL Type 12. This allows the majority of the drive's heat to be exhausted out the back of the cabinet while keeping the cabinet protected. Power ratings range from 75 to 700 HP (Frames 5-10).
- **Zero Stacking™** – Frame 0-6 drives can be mounted next to each other with no reduction of surrounding air temperature rating (50°C). This unique bookshelf design also allows access to one drive without disturbing another.

Space Saving Hardware Features

- **Integral EMC Filtering** plus built-in DC bus choke common mode cores and common mode capacitors provides a compact, all-in-one package solution for meeting EMC requirements, including CE in Europe. Frames 0-6 only.
- **Internal Communications** allow the user to integrate the drive into the manufacturing process. Status indicators for all internal communication options are visible on the cover for easy setup and monitoring of drive communications. Users can easily manage information from shop floor to top floor and seamlessly integrate their complete system as they control, configure and collect data.
- **Integral Dynamic Brake Transistor** delivers a cost effective means of switching regenerative energy without costly external chopper circuits. These internal transistors are available in power ratings from 0.5 to 200 HP.
- **Internal Dynamic Brake Resistor** (up to 25 HP) requires no extra panel space, and supplies a large amount of braking torque for short periods.

Easy to Use Human Interface Tools

The PowerFlex 7-Class AC drives provide common Human Interface tools that are familiar and easy to use. These include the LCD Human Interface modules and PC-based configuration tools.

- LCD Human Interface modules provide:
 - Large and easy to read 7 line x 21 character backlit display
 - Variety of languages (English, French, German, Italian, Spanish, Portuguese, Dutch)
 - Alternate function keys for shortcuts to common tasks
 - “Calculator-like” number pad for fast and easy data entry (Full Numeric version only)
 - Control keys for local start, stop, speed, and direction
 - Remote versions for panel mount application
- PC-based Configuration tools include:
 - DriveExplorer™ and DriveExplorer Lite. Simple and flexible “On-line” tools for monitoring and configuring while connected to a drive.
 - DriveTools™ SP. A suite of software tools which provide an intuitive means for programming, troubleshooting and maintaining Allen-Bradley AC & DC drives.
- For simplified AC drive start-up and reduced development time, we've integrated Allen-Bradley PowerFlex drive configuration with RSLogix5000® software. This single-software approach simplifies parameter and tag programming while still allowing stand-alone drive software tool use on the factory floor.

Outstanding Control and Performance

Multiple motor control algorithms allow performance matched to the application need:

- **Volts/Hertz** for simple Fan and Pump applications.
- **Sensorless Vector** for high torque production over a wide speed range.
- **Vector** for outstanding torque regulation and excellent low speed/zero speed performance (w/Vector Control cassette).

The PowerFlex 700 drive's Vector Control uses Allen-Bradley's patented Force™ Technology which provides excellent low-speed performance - whether it is operated with or without feedback. While this industry-leading control provides the highest level of drive performance, it is as easy to use as any general purpose drive available.

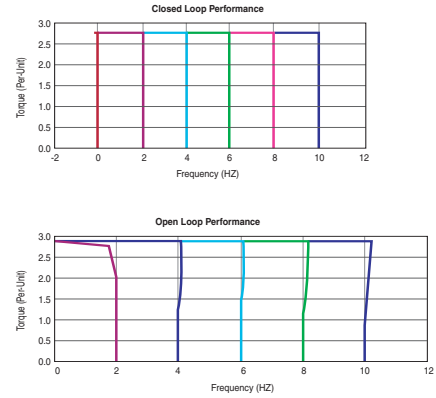

Drives Features

- Fast-acting **Current Limit** and **Bus Voltage Regulation** result in maximum accel/decel without tripping.
- **High speed analog inputs** improve drive response to torque or speed commands.
- **Programming flexibility** allows parameters to be linked within the drive.
- **Flying Start** delivers smooth and instantaneous connection into rotating loads, regardless of commanded direction, without the need for any speed feedback.
- **Integral Process PI Control** can eliminate the need for a separate process loop controller.
- **Inertia Ride-Through** offers triplex operation during a prolonged power outage by using the rotating energy stored in high inertia, low-friction loads.
- **Position Indexer/Speed Profiler** uses a 16 step indexer to provide point-to-point positioning or velocity profiling based on encoder counts, digital inputs, parameter levels or time.
- **TorqProve™** assures control of the load when transferring control between the drive and a mechanical brake.
- **Speed Regulation** - Open Loop or Closed Loop
 - **Slip Compensation** delivers a minimum 0.5% speed regulation without feedback hardware.
 - **Droop** allows drives to load share without fighting each other.
 - **Encoder Feedback** provides up to 0.001% speed regulation for the tightest application requirements.
- **Torque Regulation** - Open Loop or Closed Loop
 - **Open Loop** torque regulation provides ±5% regulation.
 - **Encoder Feedback** provides ±2% regulation and the ability to hold full load at zero speed.

Unsurpassed Capability in Network Communications

PowerFlex drives are fully compatible with the wide variety of Allen-Bradley DPI™ communication adapters, offering the following benefits:

BACnet®	Bluetooth®	ControlNet™	DeviceNet™	EtherNet/IP™	Interbus™	LonWorks™	Modbus RTU	PROFIBUS™	Remote I/O	RS485 DF1	USB	Description
		✓	✓	✓								(Unconnected Messaging) permits other network devices (e.g. PanelView™) to communicate directly to a drive without routing the communication through the network scanner.
✓	✓	✓	✓	✓							✓	Adapter Routing - Plug PC into one drive and talk to all other Allen-Bradley drives on same network, without being routed through network scanner.
✓	✓	✓	✓	✓	✓	✓	✓	✓	✓	✓	✓	Access to 100% of all parameters over the network.
✓			✓	✓				✓				AutoBaud capability makes initial connections less problematic.
			✓	✓								Change of State significantly reduces network traffic by configuring control messages to be sent only upon customer defined states. Very flexible configuration for each node (Example: "reference must change by more than 5%").
			✓	✓								Peer Control provides master-slave type control between drives, where one or more slave drives (consumers) can run based on the status of a master drive (producer), which can also significantly reduce network traffic.
			✓									ADR (Automatic Device Replacement) saves significant time and effort when replacing a drive, by allowing the scanner to be configured to automatically detect a new drive and download the required parameter settings.
✓	✓	✓	✓	✓	✓	✓	✓	✓	✓	✓	✓	Flexible Fault Configuration - Adapters can be programmed to take fault based actions as ramp to stop, coast-to-stop and hold last state, as well as send user configurable logic control and speed reference values. In addition, different actions can be taken based on whether the network experienced a serious problem (broken cable etc.) versus network idle condition (PLC set to "Program").

Catalog Number Explanation

1-3			4	5-7		8	9	10	11		12	13	14	15	16	17-18		19-20
20B			D	2P1		A	3	A	Y		N	A	R	C	0	NN		AD
<i>a</i>			<i>b</i>	<i>c</i>		<i>d</i>	<i>e</i>	<i>f</i>	<i>g</i>		<i>h</i>	<i>i</i>	<i>j</i>	<i>k</i>	<i>l</i>	<i>m</i>		<i>n</i>

a

Drive	
Code	Type
20B	PowerFlex 700

b

Voltage Rating				
Code	Voltage	Ph.	Prechg.	Frames
B	240V ac	3	-	0...6
C	400V ac	3	-	0...10
D	480V ac	3	-	0...10
E	600V ac	3	-	0...6
F	690V ac	3	-	5...6
H	540V dc	-	N	5...6, 10
J	650V dc	-	N	5...6, 10
N	325V dc	-	Y	5...6
P	540V dc	-	Y	5...9
R	650V dc	-	Y	5...9
T	810V dc	-	Y	5...6
W	932V dc	-	Y	5...6

c1

ND Rating			
208/240V, 60 Hz Input			
Code	208V Amps	240V Amps	Hp
2P2	2.5	2.2	0.5
4P2	4.8	4.2	1.0
6P8	7.8	6.8	2.0
9P6	11	9.6	3.0
015	17.5	15.3	5.0
022	25.3	22	7.5
028	32.2	28	10
042	48.3	42	15
052	56	52	20
070	78.2	70	25
080	92	80	30
104	120	104	40
130	130	130	50
154	177	154	60
192	221	192	75
260	260	260	100

c2

ND Rating		
400V, 50 Hz Input		
Code	Amps	kW
1P3	1.3	0.37
2P1	2.1	0.75
3P5	3.5	1.5
5P0	5.0	2.2
8P7	8.7	4.0
011	11.5	5.5
015	15.4	7.5
022	22	11
030	30	15
037	37	18.5
043	43	22
056	56	30
072	72	37
085	85	45
105	105	55
140	140	75
170	170	90
205	205	110
260	260	132
292	292	160
325	325	180
365	365	200
415	415	240
481	481	280
535	535	300
600	600	350
700	700	400
875	875	500

c3

ND Rating		
480V, 60 Hz Input		
Code	Amps	Hp
1P1	1.1	0.5
2P1	2.1	1.0
3P4	3.4	2.0
5P0	5.0	3.0
8P0	8.0	5.0
011	11	7.5
014	14	10
022	22	15
027	27	20
034	34	25
040	40	30
052	52	40
065	65	50
077	77	60
096	96	75
125	125	100
156	156	125
180	180	150
248	248	200
292	292	250
325	325	250
365	365	300
415	415	350
481	481	400
535	535	450
600	600	500
700	700	600
875	875	700

Position													
1-3	4	5-7	8	9	10	11	12	13	14	15	16	17-18	19-20
20B	D	2P1	A	3	A	Y	N	A	R	C	0	NN	AD
<i>a</i>	<i>b</i>	<i>c</i>	<i>d</i>	<i>e</i>	<i>f</i>	<i>g</i>	<i>h</i>	<i>i</i>	<i>j</i>	<i>k</i>	<i>l</i>	<i>m</i>	<i>n</i>

<i>c4</i>		
ND Rating		
600V, 60 Hz Input		
Code	Amps	Hp
1P7	1.7	1.0
2P7	2.7	2.0
3P9	3.9	3.0
6P1	6.1	5.0
9P0	9.0	7.5
011	11	10
017	17	15
022	22	20
027	27	25
032	32	30
041	41	40
052	52	50
062	62	60
077	77	75
099	99	100
125	125	125
144	144	150

<i>c5</i>		
ND Rating		
690V, 50 Hz Input		
Code	Amps	kW
052	52	45
060	60	55
082	82	75
098	98	90
119	119	110
142	142	132

<i>d</i>	
Enclosure	
Code	Enclosure
A	IP20, NEMA/UL Type 1
F ‡	Flange Mount
N §	Front: IP00, NEMA/UL Type Open Back/Heatsink: IP54, NEMA/UL Type 12
G ‡	Stand-Alone/Wall Mount IP54, NEMA/UL Type 12
M †	IP20, NEMA/UL Type 1 with Conformal Coat

‡ Only available for Frame 5 & Frame 6 drives, 400...690V.
§ Only available for Frames 7...10.
† Only available with Vector Control option.

<i>e</i>	
HIM	
Code	Operator Interface
0	Blank Cover
3	Full Numeric LCD
5	Prog. Only LCD
J >	Remote (Panel Mount), IP66, NEMA/UL Type 12 Full Numeric LCD HIM
K >	Remote (Panel Mount), IP66, NEMA/UL Type 12 Prog. Only LCD HIM

> Available with Frames 5...6 Stand-Alone IP54 drives (Enclosure Code "G") and Frames 8...10 IP20 drives (Enclosure Code "A").

<i>f</i>	
Documentation	
Code	Type
A	User Manual
N	No Manual
C	Chinese Documentation

<i>g</i>	
Brake	
Code	w/Brake IGBT ‡
Y	Yes
N	No

‡ Brake IGBT is standard on Frames 0-3, optional on Frames 4-6 and not available on Frames 7...10.

<i>h</i>	
Brake Resistor	
Code	w/Resistor
Y	Yes *
N	No

* Not available for Frame 3 drives or larger.

<i>i †</i>		
Emission		
Code	CE Filter ‡	CM Choke
A	Yes	Yes
B	Yes	No
N	No	No

‡ Note: 600V class drives below 77 Amps (Frames 0-4) are declared to meet the Low Voltage Directive. It is the responsibility of the user to determine compliance to the EMC directive. CE Certification testing has not been performed on Frame 7...10 drives (all voltages).

† Refer to *Internal EMC Filter* for details on selecting this option for each frame size.

<i>j</i>	
Comm Slot	
Code	Version
B	BACnet MS/TP
C	ControlNet (Coax)
D	DeviceNet
E	EtherNet/IP
R	Remote I/O
S	RS485 DF1
N	None

<i>k</i>		
I/O		
Code	Control	I/O Volts
A	Std.	24V dc/ac
B	Std.	115V ac
C	Vector ‡	24V dc
D	Vector ‡	115V ac
N	Std.	None

‡ Vector Control Option utilizes DPI Only. Frame 7...10 drives only accept Vector Control.

<i>l</i>	
Feedback	
Code	Type
0	None
1	Encoder, 12V/5V

<i>m</i>	
Future Use	

<i>n</i>	
Special Firmware	
Code	Type
AD >	60 Hz Maximum
AE >	Cascading Fan/Pump Control

> Must be used with Vector Control option C or D (Position k). Positions m-n are only required when custom firmware is supplied.

Factory Installed Options

Conformal Coat (Position d = M)

Description	Frame
Conformal Coat Printed circuit boards are coated with HumiSeal 1B73 acrylic coating to provide improved resistance to dust and moisture. Consult factory for additional details.	0
	1
	2
	3
	4
	5
	6
	7
	8
	9
	10

Human Interface and Wireless Interface Modules (Pos. e)



Cat. Code: 0
No HIM (Blank Plate)
IP20, NEMA/UL Type 1



Cat. Code: 3
LCD Display, Full
Numeric Keypad
IP20, NEMA/UL Type 1



Cat. Code: 5
LCD Display,
Programmer Only
IP20, NEMA/UL Type 1



Cat. Code: J
Remote (Panel Mount)
LCD Display,
Full Numeric Keypad
IP66, NEMA/UL Type
4x/12



Cat. Code: K
Remote (Panel Mount)
LCD Display,
Programmer Only
IP66, NEMA/UL Type
4x/12

Documentation

Description	Cat. Code (Position f)
User Manual	A
No User Manual	N
Chinese Documentation	C

Internal Brake IGBT *

Drive Input Voltage	Brake IGBT	Frame	Cat. Code (Position g)
208...480V ac	Standard	0...3	Y
208...480V ac	Optional	4	Y
208...690V ac	Optional	5	Y
208...690V ac	Optional	6	Y

* The Internal Brake IGBT option cannot be field installed.

Internal Dynamic Brake Resistors

These resistors have a limited duty cycle. Refer to the PowerFlex Dynamic Braking Selection Guide to determine if an internal resistor will be sufficient. An external resistor may be required.

Drive Input Voltage	Frame	Brake Resistance	Cat. Code
		Ω	(Position h)
208...240V ac	0	62	Y
	1 (2...5 Hp)	62	Y
	1 (7.5 Hp)	22	Y
	2	22	Y
380...600V ac	0	115	Y
	1	115	Y
380...480V ac	2	68	Y

Internal EMC Filter and Common Mode Choke

Drive Input Voltage	Frame	CE Filter	Common Mode Choke	Cat. Code (Position i)
208...240V ac	3 §	w/Filter	with Choke	A
208...240V ac	0...3	w/Filter	No Choke	B
208...240V ac	4...6	w/Filter	with Choke	A
380...480V ac	0...6	w/Filter	with Choke	A
380...480V ac	7...10	No Filter*	No Choke	N
600...690V ac	0...6	w/Filter*	with Choke	A

* Note: CE Certification testing has not been performed on 600V class drives below 77 Amps or Frame 7...10 drives.

§ Applies only to the 52 Amp drive.

Internal Communication Adapters

Description	Cat. Code (Position j)
BACnet® MS/TP RS485 Communication Adapter	B
ControlNet™ Communication Adapter (Coax)	C
DeviceNet™ Communication Adapter	D
EtherNet/IP™ Communication Adapter	E
Remote I/O Communication Adapter	R
RS485 DF1 Communication Adapter	S

Control and I/O Options

Control	Cat. Code (Position k)
Standard Control (Open Loop) - No I/O	N
Standard Control (Open Loop) - 24V dc/ac	A
Standard Control (Open Loop) - 115V ac	B
Vector Control (Series B) - 24V dc‡▲	C
Vector Control (Series B) - 115V ac‡▲	D

‡ Vector Control option utilizes DPI Only.

▲ Frames 7...10 MUST select a Vector Control option.

Feedback Options (Vector Control Only)

Description	Cat. Code (Position I)
No Encoder	0
12V/5V Encoder >	1

> Encoder option can also be used as a pulse input.

Special Firmware

Description	Cat. Code (Position m...n)
60 Hz Maximum	NNAD [⊗]
Cascading Fan/Pump Control	NNAE [⊗]

[⊗] Must be used with Vector Control option C or D (position k).

User Installed Options

Human Interface and Wireless Interface Modules



No HIM (Blank Plate)
20-HIM-A0



LCD Display, Full
Numeric Keypad
20-HIM-A3



LCD Display,
Programmer Only
20-HIM-A5



Wireless Interface
Module
20-WIM-N1



Remote (Panel Mount)
LCD Display, Full
Numeric Keypad
20-HIM-C3S



Remote (Panel Mount)
LCD Display,
Programmer Only
20-HIM-C5S



Remote (Panel Mount)
Wireless Interface
Module
20-WIM-N4S

Description	Handheld/Local (Drive Mount)	Remote (Panel Mount) IP66, NEMA/UL Type 4x/12 *
	Cat. No.	Cat. No.
No HIM (Blank Plate)	20-HIM-A0	-
LCD Display, Full Numeric Keypad	20-HIM-A3	20-HIM-C3S ‡
LCD Display, Programmer Only	20-HIM-A5	20-HIM-C5S ‡
Wireless Interface Module	20-WIM-N1	20-WIM-N4S

* For indoor use only.

‡ Includes a 1202-C30 interface cable (3 meters) for connection to drive.

Human Interface Module Accessories

Description	Cat. No.
Bezel Kit for LCD HIMs, NEMA/UL Type 1 ‡	20-HIM-B1
PowerFlex HIM Interface Cable, 1 m (39 in) ⚡	20-HIM-H10
Cable Kit (Male-Female) >	
0.33 Meters (1.1 Feet)	1202-H03
1 Meter (3.3 Feet)	1202-H10
3 Meter (9.8 Feet)	1202-H30
9 Meter (29.5 Feet)	1202-H90
DPI/SCANport™ One to Two Port Splitter Cable	1203-S03

‡ Includes a 1202-C30 interface cable (3 meters) for connection to drive.

⚡ Required only when HIM is used as handheld or remote.

> Required in addition to 20-HIM-H10 for distances up to a total maximum of 10 Meters (32.8 Feet).

Control Cassette Option Kits

Control with I/O	Cat. No.
Standard Control (Open Loop) - No I/O	20B-STD-N
Standard Control (Open Loop) - 24V dc/ac	20B-STD-A0
Standard Control (Open Loop) - 115V ac	20B-STD-B0
Vector Control (Series B) - 24V dc +	20B-VECTB-C0
Vector Control (Series B) - 24V dc, Conformal Coat +	20B-VECTB-C0-MX3
Vector Control (Series B) - 115V ac +	20B-VECTB-D0
Vector Control (Series B) - 115V ac, Conformal Coat +	20B-VECTB-D0-MX3

+ Vector Control option utilizes DPI Only.

I/O Option Kit (Standard Control Only)

Description	Cat. No.
24V dc/ac	20-DA1-A0
115V ac	20-DA1-B0

Encoder Option Kit (Vector Control Only)

Description	Cat. No.
12V/5V Encoder	20B-ENC-1
12V/5V Encoder with Conformal Coat	20B-ENC-1-MX3

Communication Option Kits

Description	Cat. No.
BACnet® MS/TP RS485 Communication Adapter	20-COMM-B
ControlNet™ Communication Adapter (Coax)	20-COMM-C
ControlNet™ Communication Adapter (Coax) Conformal Coat	20-COMM-C-MX3
DeviceNet™ Communication Adapter	20-COMM-D
DeviceNet™ Communication Adapter Conformal Coat	20-COMM-D-MX3
EtherNet/IP™ Communication Adapter	20-COMM-E
EtherNet/IP™ Communication Adapter Conformal Coat	20-COMM-E-MX3
HVAC Communication Adapter ❖	20-COMM-H
Interbus™ Communication Adapter	20-COMM-I
CANopen® Communication Adapter	20-COMM-K
LonWorks® Communication Adapter ▲	20-COMM-L
Modbus/TCP Communication Adapter	20-COMM-M
PROFIBUS™ DP Communication Adapter	20-COMM-P
ControlNet™ Communication Adapter (Fiber)	20-COMM-Q
Remote I/O Communication Adapter	20-COMM-R
Remote I/O Communication Adapter Conformal Coat	20-COMM-R-MX3
RS485 DF1 Communication Adapter	20-COMM-S
RS485 DF1 Communication Adapter Conformal Coat	20-COMM-S-MX3
External Communications Kit Power Supply	20-XCOMM-AC-PS1
DPI External Communications Kit	20-XCOMM-DC-BASE
External DPI I/O Option Board ‡	20-XCOMM-IO-OPT1
Compact I/O Module (3 Channel)	1769-SM1
Serial Null Modem Adapter	1203-SNM
Smart Self-powered Serial Converter (RS232) includes 1203-SFC and 1202-C10 Cables	1203-SSS
Universal Serial Bus™ (USB) Converter includes 2m USB, 20-HIM-H10 & 22-HIM-H10 Cables	1203-USB

‡ For use only with DPI External Communications Kits 20-XCOMM-DC-BASE.

❖ Only Modbus RTU can be used with Vector Control.

▲ Can only be used with Standard Control.

Dynamic Brake, Chopper Only Kits

Description	Rating	Cat. No.
200...240V ac	18A	1336-WA018
	70A	1336-WA070
	115A	1336-WA115
380...480V ac	9A	1336-WB009
	35A	1336-WB035
	110A	1336-WB110
500...600V ac	9A	1336-WC009
	35A	1336-WC035
	85A	1336-WC085

Internal Dynamic Brake Resistor Kits

These resistors have a limited duty cycle. Refer to the PowerFlex Dynamic Braking Selection Guide to determine if an internal resistor will be sufficient for your application. An external resistor may be required.

Drive Input Voltage	Brake Resistance	Frame	Cat. No.
	Ω		
208...240V ac	62	0	20BB-DB1-0
	62	1 (2...5 Hp)	20BB-DB1-1
	22	1 (7.5 Hp)	20BB-DB2-1
	22	2	20BB-DB1-2
380...600V ac	115	0	20BD-DB1-0
	115	1	20BD-DB1-1
380...480V ac	68	2	20BD-DB1-2

Reflected Wave Reduction Modules

Description †	Cat. No.
17A with Common Mode Choke	1204-RWC-17-A
9A without Choke, Book Mount	1204-RWR2-09-B
9A without Choke, Stack Mount	1204-RWR2-09-C

† Refer to Appendix A of publication *DRIVES-IN001* for selection information.

Reflected Wave Reduction Devices

Voltage	Drive Cat. No.	ND Hp	Cat. No.	
480V ac	20BD8P0	5.0	1321-RWR8-DP	
	20BD011	7.5	1321-RWR12-DP	
	20BD014	10.0	1321-RWR18-DP	
	20BD022	15.0	1321-RWR25-DP	
	20BD027	20.0	1321-RWR35-DP	
	20BD034	25.0	1321-RWR35-DP	
	20BD040	30.0	1321-RWR45-DP	
	20BD052	40.0	1321-RWR55-DP	
	20BD065	50.0	1321-RWR80-DP	
	20BD077	60.0	1321-RWR80-DP	
	20BD096	75.0	1321-RWR100-DP	
	20BD125	100.0	1321-RWR130-DP	
	20BD156	125.0	1321-RWR160-DP	
	20BD180	150.0	1321-RWR200-DP	
	20BD248	200.0	1321-RWR250-DP	
	20BD292	250.0	1321-RWR320-DP	
	600V ac	20BE6P1	5.0	1321-RWR8-EP
		20BE9P0	7.5	1321-RWR12-EP
		20BE011	10.0	1321-RWR12-EP
		20BE017	15.0	1321-RWR18-EP
20BE022		20.0	1321-RWR25-EP	
20BE027		25.0	1321-RWR35-EP	
20BE032		30.0	1321-RWR35-EP	
20BE041		40.0	1321-RWR45-EP	
20BE052		50.0	1321-RWR55-EP	
20BE062		60.0	1321-RWR80-EP	
20BE077		75.0	1321-RWR80-EP	
20BE099		100.0	1321-RWR100-EP	
20BE125		125.0	1321-RWR130-EP	
20BE144		150.0	1321-RWR160-EP	

Terminal Block Replacement Kit

Description	Cat. No.
Removable I/O Terminal Block	SK-G9-TB1-S1
Removable Encoder Terminal Block	SK-G9-TB1-ENC1

Terminators

Description +	Cat. No.
for use with 3.7 kW (5 Hp) & below drives	1204-TFA1
for use with 1.5 kW (2 Hp) & up drives	1204-TFB2

+ Refer to Appendix A of publication *DRIVES-IN001* for selection information.

PC Programming Software

Description	
DriveTools™ SP Software +	See publication 9303-PL002... for ordering/pricing information.
DriveExplorer™ Software (Lite/Full) + ✧	
Pocket DriveExplorer™ Software	

+ Set-up wizards are available for use with DriveTools SP and DriveExplorer (Lite/Full) only.

✧ DriveExplorer Lite is available for free download at: http://www.ab.com/drives/driveexplorer/free_download.html.

Isolation Transformers

For installations that have specific types of AC supply configurations or require drive protection due to AC line disturbances, isolation transformers are available.

Motor Rating kW (Hp)	IP32 (NEMA/UL Type 3R)		
	240V, 60 Hz, Three-Phase, 240V Primary & 240V Secondary	460V, 60 Hz, Three-Phase, 460V Primary & 460V Secondary	575V, 60 Hz, Three-Phase, 575V Primary & 575V Secondary
	Cat. No.	Cat. No.	Cat. No.
0.25 (0.33)	1321-3TW005-AA	1321-3TW005-BB	–
0.37 (0.5)	1321-3TW005-AA	1321-3TW005-BB	–
0.55 (0.75)	1321-3TW005-AA	1321-3TW005-BB	–
0.75 (1.0)	1321-3TW005-AA	1321-3TW005-BB	1321-3TW005-CC
1.1 (1.5)	1321-3TW005-AA	1321-3TW005-BB	–
1.5 (2.0)	1321-3TW005-AA	1321-3TW005-BB	1321-3TW005-CC
2.2 (3.0)	1321-3TW005-AA	1321-3TW005-BB	1321-3TW005-CC
4.0 (5.0)	1321-3TW007-AA	1321-3TW007-BB	1321-3TW007-CC
5.5 (7.5)	1321-3TW011-AA	1321-3TW011-BB	1321-3TW011-CC
7.5 (10)	1321-3TW014-AA	1321-3TW014-BB	1321-3TW014-CC
11 (15)	1321-3TW020-AA	1321-3TW020-BB	1321-3TW020-CC
15 (20)	1321-3TW027-AA	1321-3TW027-BB	1321-3TW027-CC
18.5 (25)	1321-3TW034-AA	1321-3TW034-BB	1321-3TW034-CC
22 (30)	1321-3TW040-AA	1321-3TW040-BB	1321-3TW040-CC
30 (40)	1321-3TW051-AA	1321-3TW051-BB	1321-3TW051-CC
37 (50)	1321-3TH063-AA	1321-3TH063-BB	1321-3TH063-CC
45 (60)	1321-3TH075-AA	1321-3TH075-BB	1321-3TH075-CC
55 (75)	1321-3TH093-AA	1321-3TH093-BB	1321-3TH093-CC
75 (100)	–	1321-3TH118-BB	1321-3TH118-CC
90 (125)	–	1321-3TH145-BB	1321-3TH145-CC
110 (150)	–	1321-3TH175-BB	1321-3TH175-CC
149 (200)	–	1321-3TH220-BB	1321-3TH220-CC
187 (250)	–	1321-3TH275-BB	1321-3TH275-CC
224 (300)	–	1321-3TH330-BB	1321-3TH330-CC
261 (350)	–	1321-3TH440-BB	1321-3TH440-CC
298 (400)	–	1321-3TH440-BB	1321-3TH440-CC
336 (450)	–	1321-3TH550-BB	1321-3TH550-CC
373 (500)	–	1321-3TH550-BB	1321-3TH550-CC
448 (600)	–	1321-3TH660-BB	1321-3TH660-CC
485 (650)	–	–	1321-3TH770-CC
522 (700)	–	1321-3TH770-BB	1321-3TH770-CC

Input/Output Line Reactors

For impedance matching, protection from AC line disturbances or motor protection, reactors are available for both the input and output sides of the drive.

240V, 60 Hz, Three-Phase, 3% Impedance

Drive Cat. No.	Duty	Hp	Input Line Reactor ⁽¹⁾		Output Line Reactor ⁽¹⁾	
			IP00 (NEMA/UL Type Open) Cat. No.	IP11 (NEMA/UL Type 1) Cat. No.	IP00 (NEMA/UL Type Open) Cat. No.	IP11 (NEMA/UL Type 1) Cat. No.
20BB2P2	Heavy Duty	0.33	1321-3R2-D	1321-3RA2-D	1321-3R2-D	1321-3RA2-D
20BB2P2	Normal Duty	0.5	1321-3R2-D	1321-3RA2-D	1321-3R2-D	1321-3RA2-D
20BB4P2	Heavy Duty	0.75	1321-3R4-A	1321-3RA4-A	1321-3R4-A	1321-3RA4-A
20BB4P2	Normal Duty	1	1321-3R4-A	1321-3RA4-A	1321-3R4-A	1321-3RA4-A
20BB6P8	Heavy Duty	1.5	1321-3R8-B	1321-3RA8-B	1321-3R8-A	1321-3RA8-A
20BB6P8	Normal Duty	2	1321-3R8-A	1321-3RA8-A	1321-3R8-A	1321-3RA8-A
20BB9P6	Heavy Duty	2	1321-3R8-A	1321-3RA8-A	1321-3R12-A	1321-3RA12-A
20BB9P6	Normal Duty	3	1321-3R12-A	1321-3RA12-A	1321-3R12-A	1321-3RA12-A
20BB015	Heavy Duty	3	1321-3R12-A	1321-3RA12-A	1321-3R18-A	1321-3RA18-A
20BB015	Normal Duty	5	1321-3R18-A	1321-3RA18-A	1321-3R18-A	1321-3RA18-A
20BB022	Heavy Duty	5	1321-3R18-A	1321-3RA18-A	1321-3R25-A	1321-3RA25-A
20BB022	Normal Duty	7.5	1321-3R25-A	1321-3RA25-A	1321-3R25-A	1321-3RA25-A
20BB028	Heavy Duty	7.5	1321-3R25-A	1321-3RA25-A	1321-3R35-A	1321-3RA35-A
20BB028	Normal Duty	10	1321-3R35-A	1321-3RA35-A	1321-3R35-A	1321-3RA35-A
20BB042	Heavy Duty	10	1321-3R35-A	1321-3RA35-A	1321-3R45-A	1321-3RA45-A
20BB042	Normal Duty	15	1321-3R45-A	1321-3RA45-A	1321-3R45-A	1321-3RA45-A
20BB052	Heavy Duty	15	1321-3R45-A	1321-3RA45-A	1321-3R55-A	1321-3RA55-A
20BB052	Normal Duty	20	1321-3R55-A	1321-3RA55-A	1321-3R55-A	1321-3RA55-A
20BB070	Heavy Duty	20	1321-3R55-A	1321-3RA55-A	1321-3R80-A	1321-3RA80-A
20BB070	Normal Duty	25	1321-3R80-A	1321-3RA80-A	1321-3R80-A	1321-3RA80-A
20BB080	Heavy Duty	25	1321-3R80-A	1321-3RA80-A	1321-3R80-A	1321-3RA80-A
20BB080	Normal Duty	30	1321-3R80-A	1321-3RA80-A	1321-3R80-A	1321-3RA80-A
20BB104	Heavy Duty	30	1321-3R80-A	1321-3RA80-A	1321-3R80-A	1321-3RA80-A
20BB104	Normal Duty	40	1321-3R100-A	1321-3RA100-A	1321-3R100-A	1321-3RA100-A
20BB130	Heavy Duty	40	1321-3R100-A	1321-3RA100-A	1321-3R100-A	1321-3RA100-A
20BB130	Normal Duty	50	1321-3R130-A	1321-3RA130-A	1321-3R130-A	1321-3RA130-A
20BB154	Heavy Duty	50	1321-3R130-A	1321-3RA130-A	1321-3R130-A	1321-3RA130-A
20BB154	Normal Duty	60	1321-3R160-A	1321-3RA160-A	1321-3R160-A	1321-3RA160-A
20BB192	Heavy Duty	60	1321-3R160-A	1321-3RA160-A	1321-3R160-A	1321-3RA160-A
20BB192	Normal Duty	75	1321-3R200-A	1321-3RA200-A	1321-3R200-A	1321-3RA200-A
20BB260	Heavy Duty	75	1321-3R200-A	1321-3RA200-A	1321-3R200-A	1321-3RA200-A
20BB260	Normal Duty	100	1321-3RB250-A	1321-3RAB250-A	1321-3RB250-A	1321-3RAB250-A

(1) Input line reactors were sized based on the NEC fundamental motor amps. Output line reactors were sized based on the VFD rated output currents.

240V, 60 Hz, Three-Phase, 5% Impedance

Drive Cat. No.	Duty	Hp	Input Line Reactor ⁽¹⁾		Output Line Reactor ⁽¹⁾	
			IP00 (NEMA/UL Type Open)	IP11 (NEMA/UL Type 1)	IP00 (NEMA/UL Type Open)	IP11 (NEMA/UL Type 1)
			Cat. No.	Cat. No.	Cat. No.	Cat. No.
20BB2P2	Heavy Duty	0.33	1321-3R2-A	1321-3RA2-A	1321-3R2-A	1321-3RA2-A
20BB2P2	Normal Duty	0.5	1321-3R2-A	1321-3RA2-A	1321-3R2-A	1321-3RA2-A
20BB4P2	Heavy Duty	0.75	1321-3R4-B	1321-3RA4-B	1321-3R4-B	1321-3RA4-B
20BB4P2	Normal Duty	1	1321-3R4-B	1321-3RA4-B	1321-3R4-B	1321-3RA4-B
20BB6P8	Heavy Duty	1.5	1321-3R8-B	1321-3RA8-B	1321-3R8-B	1321-3RA8-B
20BB6P8	Normal Duty	2	1321-3R8-B	1321-3RA8-B	1321-3R8-B	1321-3RA8-B
20BB9P6	Heavy Duty	2	1321-3R8-B	1321-3RA8-B	1321-3R12-B	1321-3RA12-B
20BB9P6	Normal Duty	3	1321-3R12-B	1321-3RA12-B	1321-3R12-B	1321-3RA12-B
20BB015	Heavy Duty	3	1321-3R12-B	1321-3RA12-B	1321-3R18-B	1321-3RA18-B
20BB015	Normal Duty	5	1321-3R18-B	1321-3RA18-B	1321-3R18-B	1321-3RA18-B
20BB022	Heavy Duty	5	1321-3R18-B	1321-3RA18-B	1321-3R25-B	1321-3RA25-B
20BB022	Normal Duty	7.5	1321-3R25-B	1321-3RA25-B	1321-3R25-B	1321-3RA25-B
20BB028	Heavy Duty	7.5	1321-3R25-B	1321-3RA25-B	1321-3R35-B	1321-3RA35-B
20BB028	Normal Duty	10	1321-3R35-B	1321-3RA35-B	1321-3R35-B	1321-3RA35-B
20BB042	Heavy Duty	10	1321-3R35-B	1321-3RA35-B	1321-3R45-B	1321-3RA45-B
20BB042	Normal Duty	15	1321-3R45-B	1321-3RA45-B	1321-3R45-B	1321-3RA45-B
20BB052	Heavy Duty	15	1321-3R45-B	1321-3RA45-B	1321-3R55-B	1321-3RA55-B
20BB052	Normal Duty	20	1321-3R55-B	1321-3RA55-B	1321-3R55-B	1321-3RA55-B
20BB070	Heavy Duty	20	1321-3R55-B	1321-3RA55-B	1321-3R80-B	1321-3RA80-B
20BB070	Normal Duty	25	1321-3R80-B	1321-3RA80-B	1321-3R80-B	1321-3RA80-B
20BB080	Heavy Duty	25	1321-3R80-B	1321-3RA80-B	1321-3R80-B	1321-3RA80-B
20BB080	Normal Duty	30	1321-3R80-B	1321-3RA80-B	1321-3R80-B	1321-3RA80-B
20BB104	Heavy Duty	30	1321-3R80-B	1321-3RA80-B	1321-3R80-B	1321-3RA80-B
20BB104	Normal Duty	40	1321-3R100-B	1321-3RA100-B	1321-3R100-B	1321-3RA100-B
20BB130	Heavy Duty	40	1321-3R100-B	1321-3RA100-B	1321-3R100-B	1321-3RA100-B
20BB130	Normal Duty	50	1321-3R130-B	1321-3RA130-B	1321-3R130-B	1321-3RA130-B
20BB154	Heavy Duty	50	1321-3R130-B	1321-3RA130-B	1321-3R130-B	1321-3RA130-B
20BB154	Normal Duty	60	1321-3R160-B	1321-3RA160-B	1321-3R160-B	1321-3RA160-B
20BB192	Heavy Duty	60	1321-3R160-B	1321-3RA160-B	1321-3R160-B	1321-3RA160-B
20BB192	Normal Duty	75	1321-3R200-B	1321-3RA200-B	1321-3R200-B	1321-3RA200-B
20BB260	Heavy Duty	75	1321-3R200-B	1321-3RA200-B	1321-3R200-B	1321-3RA200-B
20BB260	Normal Duty	100	1321-3RB250-B	1321-3RAB250-B	1321-3RB250-B	1321-3RAB250-B

⁽¹⁾ Input line reactors were sized based on the NEC fundamental motor amps. Output line reactors were sized based on the VFD rated output currents.

PowerFlex 700 Technical Data

480V, 60 Hz, Three-Phase, 3% Impedance

Drive Cat. No.	Duty	Hp	Input Line Reactor ⁽¹⁾		Output Line Reactor ⁽¹⁾	
			IP00 (NEMA/UL Type Open)		IP11 (NEMA/UL Type 1)	
			Cat. No.	Cat. No.	Cat. No.	Cat. No.
20BD1P1	Heavy Duty	0.33	1321-3R1-C	1321-3RA1-C	1321-3R2-B	1321-3RA2-B
20BD1P1	Normal Duty	0.5	1321-3R1-C	1321-3RA1-C	1321-3R2-B	1321-3RA2-B
20BD2P1	Heavy Duty	0.75	1321-3R2-A	1321-3RA2-A	1321-3R2-A	1321-3RA2-A
20BD2P1	Normal Duty	1	1321-3R2-A	1321-3RA2-A	1321-3R2-A	1321-3RA2-A
20BD3P4	Heavy Duty	1.5	1321-3R4-C	1321-3RA4-C	1321-3R4-B	1321-3RA4-B
20BD3P4	Normal Duty	2	1321-3R4-B	1321-3RA4-B	1321-3R4-B	1321-3RA4-B
20BD5P0	Heavy Duty	2	1321-3R4-B	1321-3RA4-B	1321-3R8-C	1321-3RA8-C
20BD5P0	Normal Duty	3	1321-3R8-C	1321-3RA8-C	1321-3R8-C	1321-3RA8-C
20BD8P0	Heavy Duty	3	1321-3R8-C	1321-3RA8-C	1321-3R8-B	1321-3RA8-B
20BD8P0	Normal Duty	5	1321-3R8-B	1321-3RA8-B	1321-3R8-B	1321-3RA8-B
20BD011	Heavy Duty	5	1321-3R8-B	1321-3RA8-B	1321-3R12-B	1321-3RA12-B
20BD011	Normal Duty	7.5	1321-3R12-B	1321-3RA12-B	1321-3R12-B	1321-3RA12-B
20BD014	Heavy Duty	7.5	1321-3R12-B	1321-3RA12-B	1321-3R18-B	1321-3RA18-B
20BD014	Normal Duty	10	1321-3R18-B	1321-3RA18-B	1321-3R18-B	1321-3RA18-B
20BD022	Heavy Duty	10	1321-3R18-B	1321-3RA18-B	1321-3R25-B	1321-3RA25-B
20BD022	Normal Duty	15	1321-3R25-B	1321-3RA25-B	1321-3R25-B	1321-3RA25-B
20BD027	Heavy Duty	15	1321-3R25-B	1321-3RA25-B	1321-3R25-B	1321-3RA25-B
20BD027	Normal Duty	20	1321-3R35-B	1321-3RA35-B	1321-3R25-B	1321-3RA25-B
20BD034	Heavy Duty	20	1321-3R35-B	1321-3RA35-B	1321-3R35-B	1321-3RA35-B
20BD034	Normal Duty	25	1321-3R35-B	1321-3RA35-B	1321-3R35-B	1321-3RA35-B
20BD040	Heavy Duty	25	1321-3R35-B	1321-3RA35-B	1321-3R45-B	1321-3RA45-B
20BD040	Normal Duty	30	1321-3R45-B	1321-3RA45-B	1321-3R45-B	1321-3RA45-B
20BD052	Heavy Duty	30	1321-3R45-B	1321-3RA45-B	1321-3R55-B	1321-3RA55-B
20BD052	Normal Duty	40	1321-3R55-B	1321-3RA55-B	1321-3R55-B	1321-3RA55-B
20BD065	Heavy Duty	40	1321-3R55-B	1321-3RA55-B	1321-3R80-B	1321-3RA80-B
20BD065	Normal Duty	50	1321-3R80-B	1321-3RA80-B	1321-3R80-B	1321-3RA80-B
20BD077	Heavy Duty	50	1321-3R80-B	1321-3RA80-B	1321-3R80-B	1321-3RA80-B
20BD077	Normal Duty	60	1321-3R80-B	1321-3RA80-B	1321-3R80-B	1321-3RA80-B
20BD096	Heavy Duty	60	1321-3R80-B	1321-3RA80-B	1321-3R80-B	1321-3RA80-B
20BD096	Normal Duty	75	1321-3R100-B	1321-3RA100-B	1321-3R100-B	1321-3RA100-B
20BD125	Heavy Duty	75	1321-3R100-B	1321-3RA100-B	1321-3R100-B	1321-3RA100-B
20BD125	Normal Duty	100	1321-3R130-B	1321-3RA130-B	1321-3R130-B	1321-3RA130-B
20BD156	Heavy Duty	100	1321-3R130-B	1321-3RA130-B	1321-3R130-B	1321-3RA130-B
20BD156	Normal Duty	125	1321-3R160-B	1321-3RA160-B	1321-3R160-B	1321-3RA160-B
20BD180	Heavy Duty	125	1321-3R160-B	1321-3RA160-B	1321-3R160-B	1321-3RA160-B
20BD180	Normal Duty	150	1321-3R200-B	1321-3RA200-B	1321-3R200-C	1321-3RA200-C
20BD248	Heavy Duty	150	1321-3R200-B	1321-3RA200-B	1321-3R200-C	1321-3RA200-C
20BD248	Normal Duty	200	1321-3RB250-B	1321-3RAB250-B	1321-3RB250-B	1321-3RAB250-B
20BD292	Heavy Duty	200	1321-3RB250-B	1321-3RAB250-B	1321-3RB250-B	1321-3RAB250-B
20BD292	Normal Duty	250	1321-3RB320-B	1321-3RAB320-B	1321-3RB320-B	1321-3RAB320-B
20BD325	Heavy Duty	250	1321-3RB320-B	1321-3RAB320-B	1321-3RB320-B	1321-3RAB320-B
20BD325	Normal Duty	250	1321-3RB320-B	1321-3RAB320-B	1321-3RB320-B	1321-3RAB320-B
20BD365	Heavy Duty	250	1321-3RB320-B	1321-3RAB320-B	1321-3RB320-B	1321-3RAB320-B
20BD365	Normal Duty	300	1321-3RB400-B	1321-3RAB400-B	1321-3RB400-B	1321-3RAB400-B
20BD415	Heavy Duty	300	1321-3RB400-B	1321-3RAB400-B	1321-3RB400-B	1321-3RAB400-B
20BD415	Normal Duty	350	1321-3RB400-B	1321-3RAB400-B	1321-3RB400-B	1321-3RAB400-B
20BD481	Heavy Duty	350	1321-3RB400-B	1321-3RAB400-B	1321-3RB400-B	1321-3RAB400-B
20BD481	Normal Duty	400	1321-3R500-B	1321-3RA500-B	1321-3R500-B	1321-3RA500-B
20BD535	Heavy Duty	400	1321-3R500-B	1321-3RA500-B	1321-3R500-B	1321-3RA500-B
20BD535	Normal Duty	450	1321-3R500-B	1321-3RA500-B	1321-3R500-B	1321-3RA500-B
20BD600	Heavy Duty	450	1321-3R500-B	1321-3RA500-B	1321-3R500-B	1321-3RA500-B
20BD600	Normal Duty	500	1321-3R600-B	1321-3RA600-B	1321-3R600-B	1321-3RA600-B
20BD700	Heavy Duty	500	1321-3R600-B	1321-3RA600-B	1321-3R600-B	1321-3RA600-B
20BD700	Normal Duty	600	1321-3R750-B	1321-3RA750-B	1321-3R600-B	1321-3RA600-B
20BD875	Heavy Duty	600	1321-3R750-B	1321-3RA750-B	1321-3R600-B	1321-3RA600-B
20BD875	Normal Duty	700	1321-3R850-B	1321-3RA850-B	1321-3R850-B	1321-3RA850-B

⁽¹⁾ Input line reactors were sized based on the NEC fundamental motor amps. Output line reactors were sized based on the VFD rated output currents.

480V, 60 Hz, Three-Phase, 5% Impedance

Drive Cat. No.	Duty	Hp	Input Line Reactor ⁽¹⁾		Output Line Reactor ⁽¹⁾	
			IP00 (NEMA/UL Type Open) Cat. No.	IP11 (NEMA/UL Type 1) Cat. No.	IP00 (NEMA/UL Type Open) Cat. No.	IP11 (NEMA/UL Type 1) Cat. No.
20BD1P1	Heavy Duty	0.33	1321-3R1-B	1321-3RA1-B	1321-3R2-C	1321-3RA2-C
20BD1P1	Normal Duty	0.5	1321-3R1-B	1321-3RA1-B	1321-3R2-C	1321-3RA2-C
20BD2P1	Heavy Duty	0.75	1321-3R2-C	1321-3RA2-C	1321-3R2-B	1321-3RA2-B
20BD2P1	Normal Duty	1	1321-3R2-B	1321-3RA2-B	1321-3R2-B	1321-3RA2-B
20BD3P4	Heavy Duty	1.5	1321-3R4-D	1321-3RA4-D	1321-3R4-D	1321-3RA4-D
20BD3P4	Normal Duty	2	1321-3R4-D	1321-3RA4-D	1321-3R4-D	1321-3RA4-D
20BD5P0	Heavy Duty	2	1321-3R4-D	1321-3RA4-D	1321-3R8-D	1321-3RA8-D
20BD5P0	Normal Duty	3	1321-3R8-D	1321-3RA8-D	1321-3R8-D	1321-3RA8-D
20BD8P0	Heavy Duty	3	1321-3R8-D	1321-3RA8-D	1321-3R8-C	1321-3RA8-C
20BD8P0	Normal Duty	5	1321-3R8-C	1321-3RA8-C	1321-3R8-C	1321-3RA8-C
20BD011	Heavy Duty	5	1321-3R8-C	1321-3RA8-C	1321-3R12-C	1321-3RA12-C
20BD011	Normal Duty	7.5	1321-3R12-C	1321-3RA12-C	1321-3R12-C	1321-3RA12-C
20BD014	Heavy Duty	7.5	1321-3R12-C	1321-3RA12-C	1321-3R18-C	1321-3RA18-C
20BD014	Normal Duty	10	1321-3R18-C	1321-3RA18-C	1321-3R18-C	1321-3RA18-C
20BD022	Heavy Duty	10	1321-3R18-C	1321-3RA18-C	1321-3R25-C	1321-3RA25-C
20BD022	Normal Duty	15	1321-3R25-C	1321-3RA25-C	1321-3R25-C	1321-3RA25-C
20BD027	Heavy Duty	15	1321-3R25-C	1321-3RA25-C	1321-3R25-C	1321-3RA25-C
20BD027	Normal Duty	20	1321-3R35-C ⁽²⁾	1321-3RA35-C ⁽²⁾	1321-3R25-C	1321-3RA25-C
20BD034	Heavy Duty	20	1321-3R35-C ⁽²⁾	1321-3RA35-C ⁽²⁾	1321-3R35-C	1321-3RA35-C
20BD034	Normal Duty	25	1321-3R35-C	1321-3RA35-C	1321-3R35-C	1321-3RA35-C
20BD040	Heavy Duty	25	1321-3R35-C	1321-3RA35-C	1321-3R45-C	1321-3RA45-C
20BD040	Normal Duty	30	1321-3R45-C	1321-3RA45-C	1321-3R45-C	1321-3RA45-C
20BD052	Heavy Duty	30	1321-3R45-C	1321-3RA45-C	1321-3R55-C	1321-3RA55-C
20BD052	Normal Duty	40	1321-3R55-C	1321-3RA55-C	1321-3R55-C	1321-3RA55-C
20BD065	Heavy Duty	40	1321-3R55-C	1321-3RA55-C	1321-3R80-C	1321-3RA80-C
20BD065	Normal Duty	50	1321-3R80-C	1321-3RA80-C	1321-3R80-C	1321-3RA80-C
20BD077	Heavy Duty	50	1321-3R80-C	1321-3RA80-C	1321-3R80-C	1321-3RA80-C
20BD077	Normal Duty	60	1321-3R80-C	1321-3RA80-C	1321-3R80-C	1321-3RA80-C
20BD096	Heavy Duty	60	1321-3R80-C	1321-3RA80-C	1321-3R80-C	1321-3RA80-C
20BD096	Normal Duty	75	1321-3R100-C	1321-3RA100-C	1321-3R100-C	1321-3RA100-C
20BD125	Heavy Duty	75	1321-3R100-C	1321-3RA100-C	1321-3R100-C	1321-3RA100-C
20BD125	Normal Duty	100	1321-3R130-C	1321-3RA130-C	1321-3R130-C	1321-3RA130-C
20BD156	Heavy Duty	100	1321-3R130-C	1321-3RA130-C	1321-3R130-C	1321-3RA130-C
20BD156	Normal Duty	125	1321-3R160-C	1321-3RA160-C	1321-3R160-C	1321-3RA160-C
20BD180	Heavy Duty	125	1321-3R160-C	1321-3RA160-C	1321-3R160-C	1321-3RA160-C
20BD180	Normal Duty	150	1321-3R200-C	1321-3RA200-C	1321-3R200-C†	1321-3RA200-C†
20BD248	Heavy Duty	150	1321-3R200-C	1321-3RA200-C	1321-3R200-C†	1321-3RA200-C†
20BD248	Normal Duty	200	1321-3RB250-C	1321-3RAB250-C	1321-3RB250-C	1321-3RAB250-C
20BD292	Heavy Duty	200	1321-3RB250-C	1321-3RAB250-C	1321-3RB250-C	1321-3RAB250-C
20BD292	Normal Duty	250	1321-3RB320-C	1321-3RAB320-C	1321-3RB320-C	1321-3RAB320-C
20BD325	Heavy Duty	250	1321-3RB320-C	1321-3RAB320-C	1321-3RB320-C	1321-3RAB320-C
20BD325	Normal Duty	250	1321-3RB320-C	1321-3RAB320-C	1321-3RB320-C	1321-3RAB320-C
20BD365	Heavy Duty	250	1321-3RB320-C	1321-3RAB320-C	1321-3RB320-C	1321-3RAB320-C
20BD365	Normal Duty	300	1321-3RB400-C	1321-3RAB400-C	1321-3RB400-C	1321-3RAB400-C
20BD415	Heavy Duty	300	1321-3RB400-C	1321-3RAB400-C	1321-3RB400-C	1321-3RAB400-C
20BD415	Normal Duty	350	1321-3R500-C	1321-3RA500-C	1321-3RB400-C	1321-3RAB400-C
20BD481	Heavy Duty	350	1321-3R500-C	1321-3RA500-C	1321-3RB400-C	1321-3RAB400-C
20BD481	Normal Duty	400	1321-3R500-C	1321-3RA500-C	1321-3R500-C	1321-3RA500-C
20BD535	Heavy Duty	400	1321-3R500-C	1321-3RA500-C	1321-3R500-C	1321-3RA500-C
20BD535	Normal Duty	450	1321-3R600-C	1321-3RA600-C	1321-3R500-C	1321-3RA500-C
20BD600	Heavy Duty	450	1321-3R600-C	1321-3RA600-C	1321-3R500-C	1321-3RA500-C
20BD600	Normal Duty	500	1321-3R600-C	1321-3RA600-C	1321-3R600-C	1321-3RA600-C
20BD700	Heavy Duty	500	1321-3R600-C	1321-3RA600-C	1321-3R600-C	1321-3RA600-C
20BD700	Normal Duty	600	1321-3R750-E	1321-3RA750-E	1321-3R750-E	1321-3RA750-E
20BD875	Heavy Duty	600	1321-3R750-E	1321-3RA750-E	1321-3R750-E	1321-3RA750-E
20BD875	Normal Duty	700	1321-3R850-C	1321-3RA850-C	1321-3R850-C	1321-3RA850-C

⁽¹⁾ Input line reactors were sized based on the NEC fundamental motor amps. Output line reactors were sized based on the VFD rated output currents.

⁽²⁾ 4% impedance.

PowerFlex 700 Technical Data

600V, 60 Hz, Three-Phase, 3% Impedance

Drive Cat. No.	Duty	Hp	Input Line Reactor ⁽¹⁾		Output Line Reactor ⁽¹⁾	
			IP00 (NEMA/UL Type Open)	IP11 (NEMA/UL Type 1)	IP00 (NEMA/UL Type Open)	IP11 (NEMA/UL Type 1)
			Cat. No.	Cat. No.	Cat. No.	Cat. No.
20BE1P7	Heavy Duty	0.5	1321-3R1-C	1321-3RA1-C	1321-3R2-B	1321-3RA2-B
20BE1P7	Normal Duty	1	1321-3R2-B	1321-3RA2-B	1321-3R2-B	1321-3RA2-B
20BE2P7	Heavy Duty	1	1321-3R2-B	1321-3RA2-B	1321-3R4-D	1321-3RA4-D
20BE2P7	Normal Duty	2	1321-3R4-D	1321-3RA4-D	1321-3R4-D	1321-3RA4-D
20BE3P9	Heavy Duty	2	1321-3R4-D	1321-3RA4-D	1321-3R4-C	1321-3RA4-C
20BE3P9	Normal Duty	3	1321-3R4-C	1321-3RA4-C	1321-3R4-C	1321-3RA4-C
20BE6P1	Heavy Duty	3	1321-3R4-C	1321-3RA4-C	1321-3R8-C	1321-3RA8-C
20BE6P1	Normal Duty	5	1321-3R8-C	1321-3RA8-C	1321-3R8-C	1321-3RA8-C
20BE9P0	Heavy Duty	5	1321-3R8-C	1321-3RA8-C	1321-3R12-C	1321-3RA12-C
20BE9P0	Normal Duty	7.5	1321-3R12-C	1321-3RA12-C	1321-3R12-C	1321-3RA12-C
20BE011	Heavy Duty	7.5	1321-3R12-C	1321-3RA12-C	1321-3R12-B	1321-3RA12-B
20BE011	Normal Duty	10	1321-3R12-B	1321-3RA12-B	1321-3R12-B	1321-3RA12-B
20BE017	Heavy Duty	10	1321-3R12-B	1321-3RA12-B	1321-3R18-B	1321-3RA18-B
20BE017	Normal Duty	15	1321-3R18-B	1321-3RA18-B	1321-3R18-B	1321-3RA18-B
20BE022	Heavy Duty	15	1321-3R18-B	1321-3RA18-B	1321-3R25-B	1321-3RA25-B
20BE022	Normal Duty	20	1321-3R25-B	1321-3RA25-B	1321-3R25-B	1321-3RA25-B
20BE027	Heavy Duty	20	1321-3R25-B	1321-3RA25-B	1321-3R35-C	1321-3RA35-C
20BE027	Normal Duty	25	1321-3R35-C	1321-3RA35-C	1321-3R35-C	1321-3RA35-C
20BE032	Heavy Duty	25	1321-3R35-C	1321-3RA35-C	1321-3R35-B	1321-3RA35-B
20BE032	Normal Duty	30	1321-3R35-B	1321-3RA35-B	1321-3R35-B	1321-3RA35-B
20BE041	Heavy Duty	30	1321-3R35-B	1321-3RA35-B	1321-3R45-B	1321-3RA45-B
20BE041	Normal Duty	40	1321-3R45-B	1321-3RA45-B	1321-3R45-B	1321-3RA45-B
20BE052	Heavy Duty	40	1321-3R45-B	1321-3RA45-B	1321-3R55-B	1321-3RA55-B
20BE052	Normal Duty	50	1321-3R55-B	1321-3RA55-B	1321-3R55-B	1321-3RA55-B
20BE062	Heavy Duty	50	1321-3R55-B	1321-3RA55-B	1321-3R80-B	1321-3RA80-B
20BE062	Normal Duty	60	1321-3R80-B	1321-3RA80-B	1321-3R80-B	1321-3RA80-B
20BE077	Heavy Duty	60	1321-3R80-B	1321-3RA80-B	1321-3R80-B	1321-3RA80-B
20BE077	Normal Duty	75	1321-3R80-B	1321-3RA80-B	1321-3R80-B	1321-3RA80-B
20BE099	Heavy Duty	75	1321-3R80-B	1321-3RA80-B	1321-3R80-B	1321-3RA80-B
20BE099	Normal Duty	100	1321-3R100-B	1321-3RA100-B	1321-3R100-B	1321-3RA100-B
20BE125	Heavy Duty	100	1321-3R100-B	1321-3RA100-B	1321-3R100-B	1321-3RA100-B
20BE125	Normal Duty	125	1321-3R130-B	1321-3RA130-B	1321-3R130-B	1321-3RA130-B
20BE144	Heavy Duty	125	1321-3R130-B	1321-3RA130-B	1321-3R130-B	1321-3RA130-B
20BE144	Normal Duty	150	1321-3R160-B	1321-3RA160-B	1321-3R160-B	1321-3RA160-B

⁽¹⁾ Input line reactors were sized based on the NEC fundamental motor amps. Output line reactors were sized based on the VFD rated output currents.

600V, 60 Hz, Three-Phase, 5% Impedance

Drive Cat. No.	Duty	Hp	Input Line Reactor ⁽¹⁾		Output Line Reactor ⁽¹⁾	
			IP00 (NEMA/UL Type Open)	IP11 (NEMA/UL Type 1)	IP00 (NEMA/UL Type Open)	IP11 (NEMA/UL Type 1)
			Cat. No.	Cat. No.	Cat. No.	Cat. No.
20BE1P7	Heavy Duty	0.5	1321-3R1-B	1321-3RA1-B	1321-3R2-C	1321-3RA2-C
20BE1P7	Normal Duty	1	1321-3R2-C	1321-3RA2-C	1321-3R2-C	1321-3RA2-C
20BE2P7	Heavy Duty	1	1321-3R2-C	1321-3RA2-C	1321-3R4-D ⁽²⁾	1321-3RA4-D ⁽²⁾
20BE2P7	Normal Duty	2	1321-3R4-D ⁽²⁾	1321-3RA4-D ⁽²⁾	1321-3R4-D ⁽²⁾	1321-3RA4-D ⁽²⁾
20BE3P9	Heavy Duty	2	1321-3R4-D ⁽²⁾	1321-3RA4-D ⁽²⁾	1321-3R4-D	1321-3RA4-D
20BE3P9	Normal Duty	3	1321-3R4-D	1321-3RA4-D	1321-3R4-D	1321-3RA4-D
20BE6P1	Heavy Duty	3	1321-3R4-D	1321-3RA4-D	1321-3R8-D	1321-3RA8-D
20BE6P1	Normal Duty	5	1321-3R8-D	1321-3RA8-D	1321-3R8-D	1321-3RA8-D
20BE9P0	Heavy Duty	5	1321-3R8-D	1321-3RA8-D	1321-3R12-C ⁽²⁾	1321-3RA12-C ⁽²⁾
20BE9P0	Normal Duty	7.5	1321-3R12-C ⁽²⁾	1321-3RA12-C ⁽²⁾	1321-3R12-C ⁽²⁾	1321-3RA12-C ⁽²⁾
20BE011	Heavy Duty	7.5	1321-3R12-C ⁽²⁾	1321-3RA12-C ⁽²⁾	1321-3R12-C	1321-3RA12-C
20BE011	Normal Duty	10	1321-3R12-C	1321-3RA12-C	1321-3R12-C	1321-3RA12-C
20BE017	Heavy Duty	10	1321-3R12-C	1321-3RA12-C	1321-3R18-C	1321-3RA18-C
20BE017	Normal Duty	15	1321-3R18-C	1321-3RA18-C	1321-3R18-C	1321-3RA18-C
20BE022	Heavy Duty	15	1321-3R18-C	1321-3RA18-C	1321-3R25-C ⁽²⁾	1321-3RA25-C ⁽²⁾
20BE022	Normal Duty	20	1321-3R25-C ⁽²⁾	1321-3RA25-C ⁽²⁾	1321-3R25-C ⁽²⁾	1321-3RA25-C ⁽²⁾
20BE027	Heavy Duty	20	1321-3R25-C ⁽²⁾	1321-3RA25-C ⁽²⁾	1321-3R35-C ⁽²⁾	1321-3RA35-C ⁽²⁾
20BE027	Normal Duty	25	1321-3R35-C ⁽²⁾	1321-3RA35-C ⁽²⁾	1321-3R35-C ⁽²⁾	1321-3RA35-C ⁽²⁾
20BE032	Heavy Duty	25	1321-3R35-C ⁽²⁾	1321-3RA35-C ⁽²⁾	1321-3R35-C ⁽²⁾	1321-3RA35-C ⁽²⁾
20BE032	Normal Duty	30	1321-3R35-C ⁽²⁾	1321-3RA35-C ⁽²⁾	1321-3R35-C ⁽²⁾	1321-3RA35-C ⁽²⁾
20BE041	Heavy Duty	30	1321-3R35-C ⁽²⁾	1321-3RA35-C ⁽²⁾	1321-3R45-C	1321-3RA45-C
20BE041	Normal Duty	40	1321-3R45-C	1321-3RA45-C	1321-3R45-C	1321-3RA45-C
20BE052	Heavy Duty	40	1321-3R45-C	1321-3RA45-C	1321-3R55-C	1321-3RA55-C
20BE052	Normal Duty	50	1321-3R55-C	1321-3RA55-C	1321-3R55-C	1321-3RA55-C
20BE062	Heavy Duty	50	1321-3R55-C	1321-3RA55-C	1321-3R80-C	1321-3RA80-C
20BE062	Normal Duty	60	1321-3R80-C	1321-3RA80-C	1321-3R80-C	1321-3RA80-C
20BE077	Heavy Duty	60	1321-3R80-C	1321-3RA80-C	1321-3R80-C	1321-3RA80-C
20BE077	Normal Duty	75	1321-3R80-C	1321-3RA80-C	1321-3R80-C	1321-3RA80-C
20BE099	Heavy Duty	75	1321-3R80-C	1321-3RA80-C	1321-3R80-C	1321-3RA80-C
20BE099	Normal Duty	100	1321-3R100-C	1321-3RA100-C	1321-3R100-C	1321-3RA100-C
20BE125	Heavy Duty	100	1321-3R100-C	1321-3RA100-C	1321-3R100-C	1321-3RA100-C
20BE125	Normal Duty	125	1321-3R130-C ⁽²⁾	1321-3RA130-C ⁽²⁾	1321-3R130-C ⁽²⁾	1321-3RA130-C ⁽²⁾
20BE144	Heavy Duty	125	1321-3R130-C ⁽²⁾	1321-3RA130-C ⁽²⁾	1321-3R130-C ⁽²⁾	1321-3RA130-C ⁽²⁾
20BE144	Normal Duty	150	1321-3R160-C ⁽²⁾	1321-3RA160-C ⁽²⁾	1321-3R160-C ⁽²⁾	1321-3RA160-C ⁽²⁾

⁽¹⁾ Input line reactors were sized based on the NEC fundamental motor amps. Output line reactors were sized based on the VFD rated output currents.

⁽²⁾ 4% impedance.

Installation Considerations

Power Wiring

The PowerFlex 700 has the following built in protective features to help simplify installation:

- Ground fault protection during start up and running ensures reliable operation
- Electronic motor overload protection increases motor life
- Removable MOV to ground and common mode capacitors to ground ensure compatibility with ungrounded systems. These devices must be disconnected if the drive is installed on a resistive grounded distribution system, an ungrounded distribution system, or a B phase grounded distribution system. These devices must also be disconnected if a regenerative unit is used as a bus supply or brake.
- 6 kV transient protection provides increased robustness for 380-480V system voltages

There are many other factors that must be considered for optimal performance in any given application. The block diagram below highlights the primary installation considerations. Consult *Wiring and Grounding Guidelines for AC Drives* (publication DRIVES-IN001) available online at www.rockwellautomation.com/literature, for detailed recommendations on input power conditioning, dynamic braking, reflected wave protection and motor cable types.

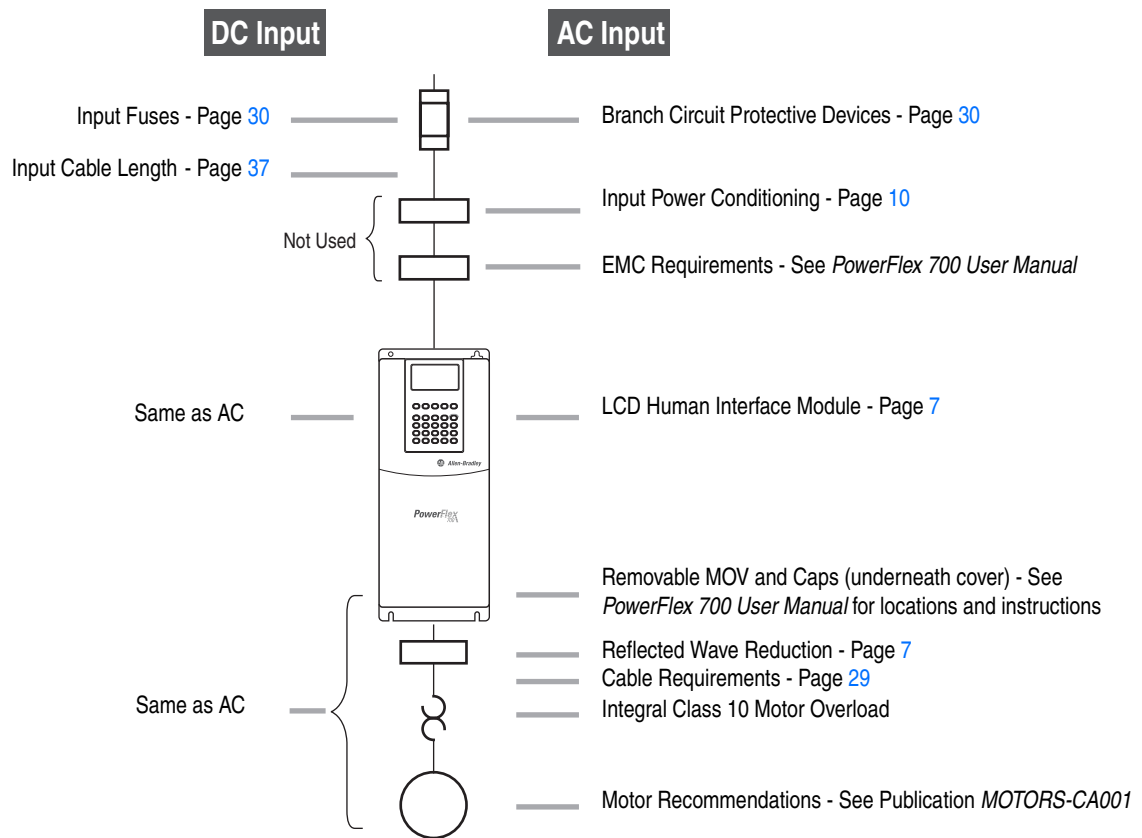

Terminal Blocks

Terminal Block Specifications

Refer to pages 19 and 20 for typical locations.

No.	Name	Frame	Description	Wire Size Range - See Note (3)		Torque	
				Maximum	Minimum	Maximum	Recommended
❶	Power Terminal Block	0 & 1	Input power and motor connections	4.0 mm ² (12 AWG)	0.5 mm ² (22 AWG)	1.7 N-m (15 lb.-in.)	0.8 N-m (7 lb.-in.)
		2	Input power and motor connections	10.0 mm ² (6 AWG)	0.8 mm ² (18 AWG)	1.7 N-m (15 lb.-in.)	1.4 N-m (12 lb.-in.)
		3	Input power and motor connections BR1, 2 terminals	25.0 mm ² (3 AWG)	2.5 mm ² (14 AWG)	3.6 N-m (32 lb.-in.)	1.8 N-m (16 lb.-in.)
				10.0 mm ² (6 AWG)	0.8 mm ² (18 AWG)	1.7 N-m (15 lb.-in.)	1.4 N-m (12 lb.-in.)
		4	Input power and motor connections	35.0 mm ² (1/0 AWG)	10.0 mm ² (6 AWG)	4.0 N-m (35 lb.-in.)	4.0 N-m (35 lb.-in.)
		5	Input power, DC+, DC-, BR1, 2, PE, motor connections 75HP, 480V/ 100HP, 600V	50.0 mm ² (1/0 AWG)	4.0 mm ² (12 AWG)	See Note (6)	
		5		100HP	70.0 mm ² (2/0 AWG)		
		6	Input power, DC+, DC-, BR1, 2, PE, motor connections	150.0 mm ² (300 MCM) see Note (4)	2.5 mm ² (14 AWG)	6.0 N-m (52 lb.-in.)	6.0 N-m (52 lb.-in.)
		7	Input power, DC+, DC-, PE, motor connections	150.0 mm ² (300 MCM) see Note (5)	2.5 mm ² (14 AWG)	10.0 N-m (87 lb.-in.)	10.0 N-m (87 lb.-in.)
10	Input power, DC+, DC-, PE, motor connections	300.0 mm ² (600 MCM) see Note (5)	2.5 mm ² (14 AWG)	10.0 N-m (87 lb.-in.)	10.0 N-m (87 lb.-in.)		
❷	SHLD Terminal	0-6	Terminating point for wiring shields	—	—	1.6 N-m (14 lb.-in.)	1.6 N-m (14 lb.-in.)
❸	AUX Terminal Block	0-4	Auxiliary Control Voltage PS+, PS- (1)/(2)	1.5 mm ² (16 AWG)	0.2 mm ² (24 AWG)	—	—
		5-6		4.0 mm ² (12 AWG)	0.5 mm ² (22 AWG)	0.6 N-m (5.3 lb.-in.)	0.6 N-m (5.3 lb.-in.)
		7, 10		4.0 mm ² (12 AWG)	0.049 mm ² (30 AWG)	0.6 N-m (5.3 lb.-in.)	0.6 N-m (5.3 lb.-in.)
❹	I/O Terminal Block	0-6	Signal & control connections	2.5 mm ² (14 AWG)	0.30 mm ² (22 AWG)	0.6 N-m (5.3 lb.-in.)	0.6 N-m (5.3 lb.-in.)
		7-10		4.0 mm ² (12 AWG)	0.049 mm ² (30 AWG)	0.6 N-m (5.3 lb.-in.)	0.6 N-m (5.3 lb.-in.)
❺	Encoder Terminal Block	0-10	Encoder power & signal connections	0.75 mm ² (18 AWG)	0.196 mm ² (24 AWG)	0.6 N-m (5.3 lb.-in.)	0.6 N-m (5.3 lb.-in.)
❻	Fan Terminal Block (DC Input Only)	5-6	User Supplied Fan Voltage	4.0 mm ² (12 AWG)	0.5 mm ² (22 AWG)	0.6 N-m (5.3 lb.-in.)	0.6 N-m (5.3 lb.-in.)
		7		4.0 mm ² (12 AWG)	0.5 mm ² (22 AWG)	0.9 N-m (8.0 lb.-in.)	0.6 N-m (5.3 lb.-in.)
		8-10		4.0 mm ² (12 AWG)	0.5 mm ² (22 AWG)	0.6 N-m (5.3 lb.-in.)	0.6 N-m (5.3 lb.-in.)

- (1) External control power: UL Installation-300V DC, ±10%, Non UL Installation-270-600V DC, ±10% (0-3 Frame-40W, 165 mA, 5 Frame-80W, 90 mA).
- (2) An Auxiliary Control Power Supply such as the 20-24V-AUX can be used with 400/480 and 600/690 Volt drives with Vector Control. However, consult the factory before using an auxiliary power supply in these instances. **Important:** The Auxiliary Control Power Supply Must Not be used with any Standard Control drive or any 200/240V PowerFlex 700 drive, Standard or Vector Control.
- (3) **Maximum/minimum sizes that the terminal block will accept - these are not recommendations.**
- (4) Two wires connected in parallel to any of these terminals using two lugs may be required
- (5) If may be necessary to connect multiple wires in parallel to these terminals using multiple lugs.
- (6) Refer to the terminal block label inside the drive.

Terminal	Description	Notes
BR1 BR2	DC Brake (+) DC Brake (-)	DB Resistor Connection - Important: Only one DB resistor can be used with Frames 0-3. Connecting an internal & external resistor could cause damage.
DC+	DC Bus (+)	DC Input/Brake Connections
DC-	DC Bus (-)	
PE	PE Ground	
PS+	Auxiliary Control Terminal Block	see page 19
PS-		
	Motor Ground	
U	U (T1)	To Motor
V	V (T2)	
W	W (T3)	
R	R (L1)	AC Line Input Power Three-Phase = R, S & T Single-Phase = R & S Only
S	S (L2)	
T	T (L3)	

Typical Terminal Block Location

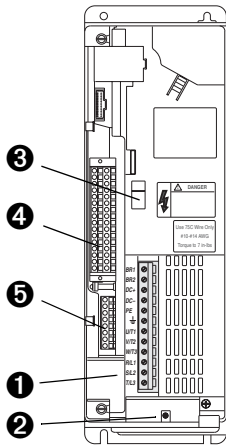

Frames 0 & 1

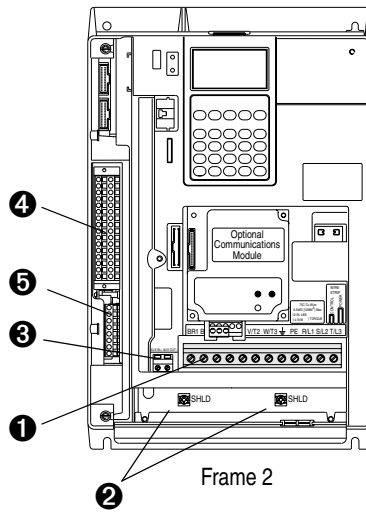

Frame 2

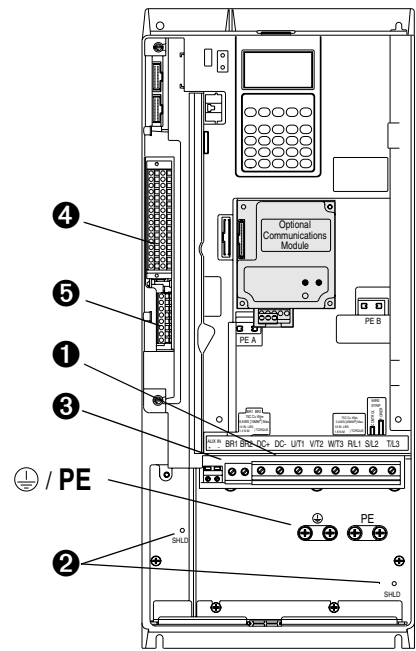

Frames 3 & 4

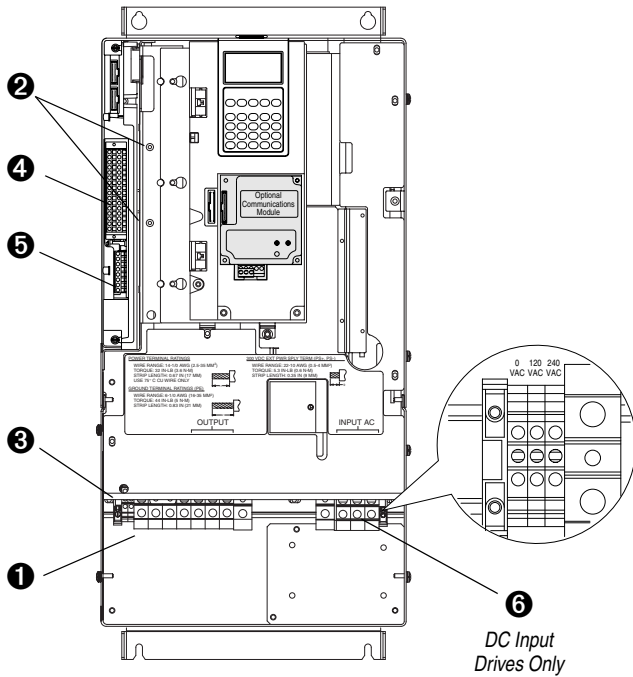

Frame 5

DC Input Drives Only

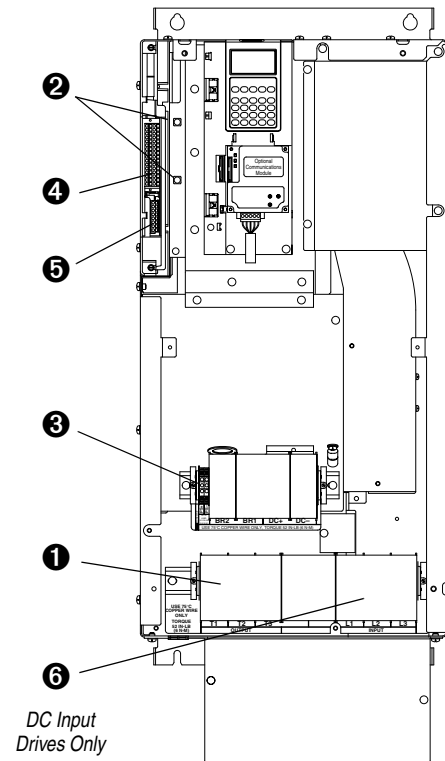

Frame 6

DC Input Drives Only

Typical Terminal Block Locations (continued)

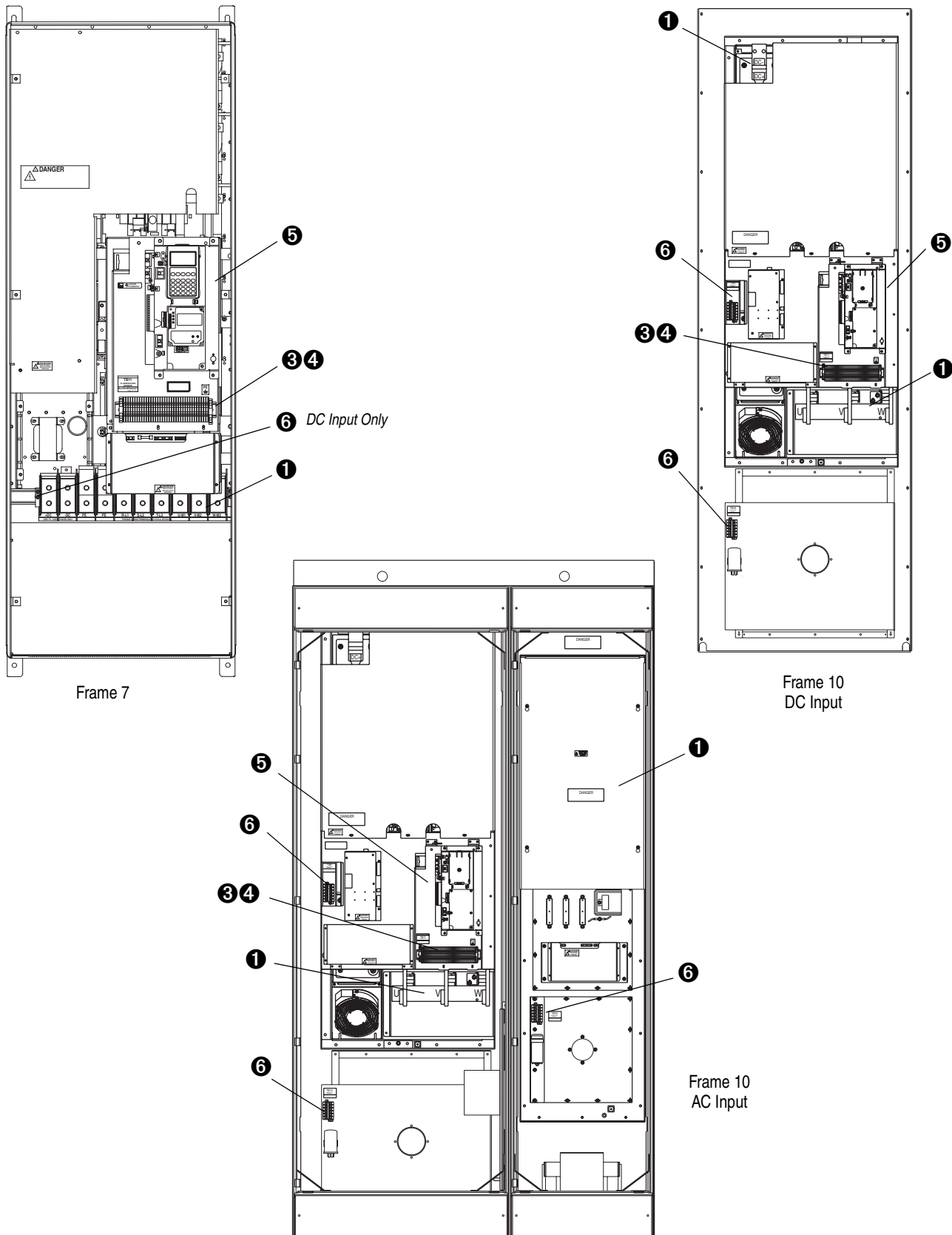

Power Terminals

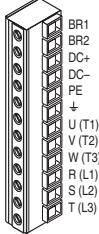
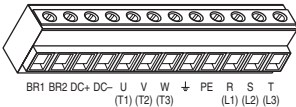
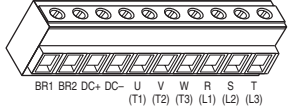
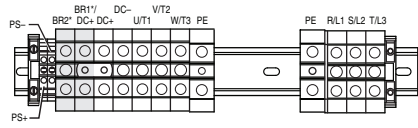
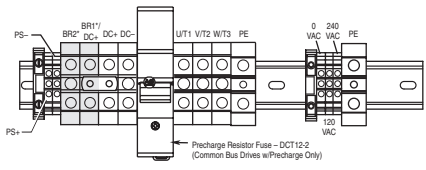
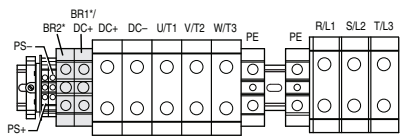
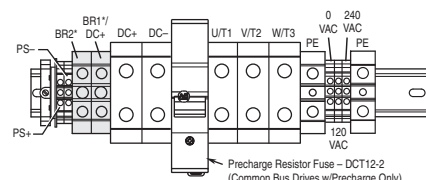
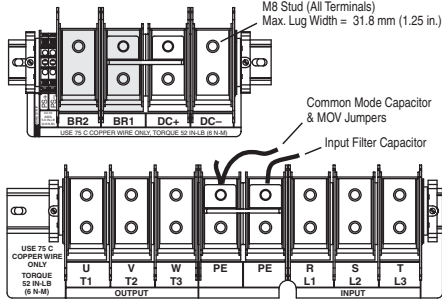
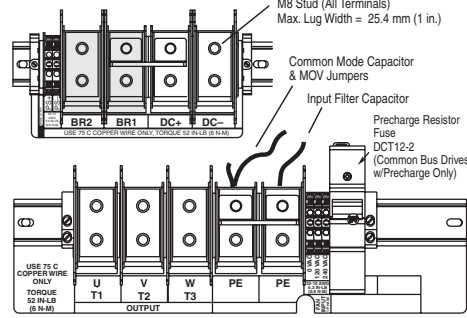
Frame	Terminal Block	
0 & 1		
2		
3 & 4		<p>* Note: Shaded BR1 & BR2 Terminals will only be present on drives ordered with the Brake Option.</p>
AC Input		DC Input
5	<p>75 HP, Normal Duty</p> 	<p>75 HP, Normal Duty</p> 
	<p>100 HP, Normal Duty</p> 	<p>100 HP, Normal Duty</p> 
6	<p>125-200 HP, Normal Duty</p> 	<p>125-200 HP, Normal Duty</p> 

Frame	Terminal Block	
	AC Input	DC Input
7		
8	Not available at time of publication.	Not available at time of publication.
9	Not available at time of publication.	Not available at time of publication.
10		

Fan Circuit Power Supply

Important: Some drives utilize a fan transformer to power the internal fan(s). This transformer is sized specifically for the internal fan(s) and must not be used to power other circuitry.

Frames 5 & 6 Fan Connections				
Drive Type	Enclosure	Rating (120VAC)	No. of Fans	Connect at ...
DC Input	IP00, NEMA/UL Type Open	100 VA (Frame 5) 138 VA (Frame 6)	1	Power Terminal Block Requires user supplied 120 or 240V AC. See page 21 for TB locations and terminal designations.
	IP20, NEMA/UL Type 1	100 VA (Frame 5) 138 VA (Frame 6)	1	
AC Input	IP00, NEMA/UL Type Open	100 VA (Frame 5) 138 VA (Frame 6)	1	N/A (Connected internally)
	IP20, NEMA/UL Type 1	100 VA (Frame 5) 138 VA (Frame 6)	1	A transformer (located behind Power TB) matches the input line voltage to the internal fan voltage. If line voltage is different than the voltage class specified on the drive nameplate, it may be necessary to change transformer taps (see below).

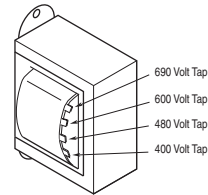

Frame 7 Fan Connections				
Drive Type	Enclosure	Rating (120VAC)	No. of Fans	Connect at ...
DC Input	IP00, NEMA/UL Type Open	250 VA	1	Power Terminal Block
	IP20, NEMA/UL Type 1	250 VA	1	Requires user supplied 120V AC. See figure above for location.
AC Input	IP00, NEMA/UL Type Open	250 VA	1	N/A (Connected internally)
	IP20, NEMA/UL Type 1	250 VA	1	

Frame 10 Fan Connections				
Drive Type	Enclosure	Rating (120VAC)	No. of Fans	Connect at ...
DC Input	IP00, NEMA/UL Type Open	1000 VA	2	TB9 & 10
	IP20, NEMA/UL Type 1	1000 VA	2	Requires user supplied 120V AC. See page 20 for TB locations and the figure below for terminal designations.
AC Input	IP00, NEMA/UL Type Open	1000 VA	3	TB9, 10 & 12 Requires user supplied 120V AC. See page 20 for TB locations and the figure below for terminal designations.
	IP20, NEMA/UL Type 1	1000 VA	3	TB9, 10 & 12 A transformer matches the input line voltage to the internal fan voltage. If line voltage is different than the voltage class specified on the drive nameplate, it may be necessary to change transformer taps (see below).

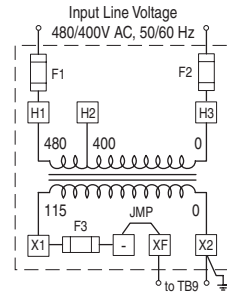

Fan Terminal Blocks – Frames 8 & 10

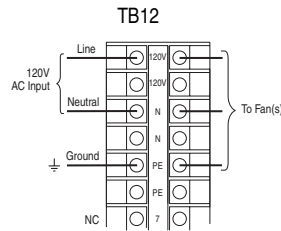
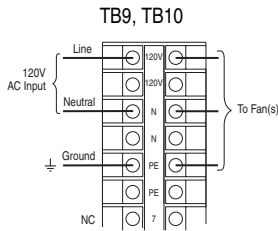

Frame 10, AC Input, IP20 Only

Fan Transformer Specifications/Fusing – Frames 8 & 10

Frame	Rating	Recommended Fuses	
		Primary (Quantity 2)	Secondary (Quantity 1)
8	500 VA	2.8A, 600V AC, KLDR/ATQR Type	6.25A, 250V AC, Time Delay
10	1000 VA	6A, 600V AC, KLDR/ATQR Type	9A, 250V AC, Time Delay

Additional Frame 10 Wiring Requirement for IP00 AC Input Drives

The Inverter and Converter sections of Frame 10 AC Input IP00, NEMA/UL Type Open drives are shipped separately. Once installed, the following connections will be required.

- **DC Link Choke Wiring**
DC link chokes are supplied loose for customer mounting and wiring in IP00 drives.
- **Thermistor Wiring**
Thermistor wiring will be coiled loose in the Converter section for shipping. The wire must be routed through the enclosure wall and connected to the mating connector located above the HIM cradle.

Control Terminals

Frames 0-6

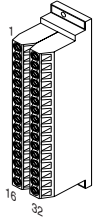

Standard Control Option (Frames 0-6)				Vector Control Option (Frames 0-6)			
No.	Signal	Factory Default	Description	No.	Signal	Factory Default	Description
1	Anlg Volts In 1 (-)	(3)	Isolated ⁽⁵⁾ , bipolar, differential, ±10V, 11 bit & sign, 88k ohm input impedance.	1	Analog In 1 (-) ⁽⁸⁾	(3)	Isolated ⁽⁵⁾ , bipolar, differential, ±10V/0-20mA, 11 bit & sign. For 0-20 mA, a jumper must be installed at terminals 17 & 18 (or 19 & 20). 88k ohm input impedance when configured for voltage and 95.3 ohm for current.
2	Anlg Volts In 1 (+)			2	Analog In 1 (+) ⁽⁸⁾		
3	Anlg Volts In 2 (-)	(3)	Isolated ⁽⁶⁾ , bipolar, differential, ±10V, 11 bit & sign, 88k ohm input impedance.	3	Analog In 2 (-) ⁽⁸⁾		
4	Anlg Volts In 2 (+)			4	Analog In 2 (+) ⁽⁸⁾		
5	Pot Common	-	For (+) and (-) 10V pot references.	5	Pot Common	-	For (+) and (-) 10V pot references.
6	Anlg Volts Out 1 (-)	(3), (4)	Bipolar, ±10V, 11 bit & sign, 2k ohm minimum load.	6	Analog Out 1 (-)	(3)	Single-ended bipolar (current output is not bipolar), ±10V/0-20mA, 11 bit & sign, voltage mode - limit current to 5 mA. Current mode - max. load resistance is 400 ohms.
7	Anlg Volts Out 1 (+)			7	Analog Out 1 (+)		
8	Anlg Current Out 1 (-)	(3), (4)	4-20mA, 11 bit & sign, 400 ohm maximum load.	8	Analog Out 2 (-)		
9	Anlg Current Out 1 (+)			9	Analog Out 2 (+)		
10	Reserved for Future Use			10	HW PTC Input 1	-	1.8k ohm PTC, Internal 3.32k ohm pull-up resistor
11	Digital Out 1 - N.C. ⁽¹⁾	Fault	Max. Resistive Load: 240V AC/30V DC - 1200VA, 150W Max. Current: 5A, Min. Load: 10mA	11	Digital Out 1 - N.C. ⁽¹⁾	Fault	Max. Resistive Load: 240V AC/30V DC - 1200VA, 150W Max. Current: 5A, Min. Load: 10mA
12	Digital Out 1 Common			12	Digital Out 1 Common		
13	Digital Out 1 - N.O. ⁽¹⁾	NOT Fault	Max. Inductive Load: 240V AC/30V DC - 840VA, 105W Max. Current: 3.5A, Min. Load: 10mA	13	Digital Out 1 - N.O. ⁽¹⁾	NOT Fault	Max. Inductive Load: 240V AC/30V DC - 840VA, 105W Max. Current: 3.5A, Min. Load: 10mA
14	Digital Out 2 - N.C. ⁽¹⁾	NOT Run		14	Digital Out 2 - N.C. ⁽¹⁾	NOT Run	
15	Digital Out 2 Common			15	Digital Out 2/3 Com.		
16	Digital Out 2 - N.O. ⁽¹⁾	Run		16	Digital Out 3 - N.O. ⁽¹⁾	Run	
17	Anlg Current In 1 (-)	(3)	Isolated ⁽⁵⁾ , 4-20mA, 11 bit & sign, 124 ohm input impedance.	17	Current In Jumper ⁽⁸⁾ -		Placing a jumper across terminals 17 & 18 (or 19 & 20) will configure that analog input for current.
18	Anlg Current In 1 (+)			18	Analog In 1		
19	Anlg Current In 2 (-)	(3)	Isolated ⁽⁶⁾ , 4-20mA, 11 bit & sign, 124 ohm input impedance.	19	Current In Jumper ⁽⁸⁾ -		
20	Anlg Current In 2 (+)			20	Analog In 2		
21	-10V Pot Reference	-	2k ohm minimum.	21	-10V Pot Reference	-	2k ohm minimum load.
22	+10V Pot Reference	-		22	+10V Pot Reference	-	
23	Reserved for Future Use			23	HW PTC Input 2	-	See "10" above
24	+24VDC ⁽⁷⁾	-	Drive supplied logic input power. ⁽⁷⁾	24	+24VDC ⁽⁷⁾	-	Drive supplied logic input power. ⁽⁷⁾
25	Digital In Common	-		25	Digital In Common	-	
26	24V Common ⁽⁷⁾	-	Common for internal power supply.	26	24V Common ⁽⁷⁾	-	Common for internal power supply.
27	Digital In 1 ⁽²⁾	Stop - CF	115V AC, 50/60 Hz - Opto isolated Low State: less than 30V AC	27	Digital In 1 ⁽²⁾	Stop - CF	115V AC, 50/60 Hz - Opto isolated Low State: less than 30V AC
28	Digital In 2 ⁽²⁾	Start		28	Digital In 2 ⁽²⁾	Start	
29	Digital In 3 ⁽²⁾	Auto/Man.	High State: greater than 100V AC, 5.0 mA	29	Digital In 3 ⁽²⁾	Auto/Man.	High State: greater than 100V AC, 5.7 mA
30	Digital In 4 ⁽²⁾	Speed Sel 1		30	Digital In 4 ⁽²⁾	Speed Sel 1	
31	Digital In 5 ⁽²⁾	Speed Sel 2	24V AC/DC, 50/60 Hz - Opto isolated Low State: less than 5V AC/DC	31	Digital In 5 ⁽²⁾	Speed Sel 2	24V DC - Opto isolated Low State: less than 5V DC
32	Digital In 6 ⁽²⁾	Speed Sel 3		32	Digital In 6/Hardware Enable, see pg. 26 ⁽²⁾	Speed Sel 3	

- (1) Contacts in unpowered state. Any relay programmed as Fault or Alarm will energize (pick up) when power is applied to drive and deenergize (drop out) when a fault or alarm exists. Relays selected for other functions will energize only when that condition exists and will deenergize when condition is removed.
- (2) A 10k ohm, 2 watt burden resistor must be installed on each digital input when using a triac type device. The resistor is installed between each digital input and neutral /common.
- (3) These inputs/outputs are dependant on a number of parameters. Refer to the PowerFlex 700 User Manual for details.
- (4) Anlg Out 1 is one output that can be configured for volts or current.
- (5) Differential Isolation - External source must be maintained at less than 160V with respect to PE. Input provides high common mode immunity.
- (6) Differential Isolation - External source must be less than 10V with respect to PE.
- (7) 150mA maximum Load. Not present on 115V versions.
- (8) **Important:** 0-20mA operation requires a jumper at terminals 17 & 18 (or 19 & 20). Drive damage may occur if jumper is not installed.

Frames 7-10

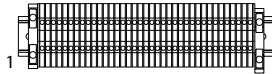

Vector Control Option (Frames 7-10)				
No.	Signal	Factory Default	Description	Related Param.
1	Analog In 1 (-) ⁽¹⁾	(2)	Isolated ⁽³⁾ , bipolar, differential, ±10V/4-20mA, 11 bit & sign, 88k ohm input impedance. For 4-20mA, a jumper must be installed at terminals 17 & 18 (or 19 & 20).	320 - 327
2	Analog In 1 (+) ⁽¹⁾			
3	Analog In 2 (-) ⁽¹⁾			
4	Analog In 2 (+) ⁽¹⁾			
5	Pot Common	-	For (+) and (-) 10V pot references.	
6	Analog Out 1 (-)	(2)	Bipolar (current output is not bipolar), ±10V/4-20mA, 11 bit & sign, voltage mode - limit current to 5 mA. Current mode - max. load resistance is 400 ohms.	340 - 347
7	Analog Out 1 (+)			
8	Analog Out 2 (-)			
9	Analog Out 2 (+)			
10	HW PTC Input 1	-	1.8k ohm PTC, Internal 3.32k ohm pull-up resistor	238 259
11	Digital Out 1 – N.C. ⁽⁴⁾	Fault	Max. Resistive Load: 240V AC/30V DC – 1200VA, 150W Max. Current: 5A, Min. Load: 10mA Max. Inductive Load: 240V AC/30V DC – 840VA, 105W Max. Current: 3.5A, Min. Load: 10mA	380 - 391
12	Digital Out 1 Common			
13	Digital Out 1 – N.O. ⁽⁴⁾	NOT Fault		
14	Digital Out 2 – N.C. ⁽⁴⁾	NOT Run		
15	Digital Out 2/3 Com.			
16	Digital Out 3 – N.O. ⁽⁴⁾	Run		
17	Current In Jumper ⁽¹⁾ – Analog In 1		Placing a jumper across terminals 17 & 18 (or 19 & 20) will configure that analog input for current.	
18	Current In Jumper ⁽¹⁾ – Analog In 2			
19	Current In Jumper ⁽¹⁾ – Analog In 2			
20				
21	-10V Pot Reference	-	2k ohm minimum load.	
22	+10V Pot Reference	-		
23	HW PTC Input 2	-	See above	
24	+24VDC ⁽⁵⁾	-	Drive supplied logic input power. ⁽⁵⁾	
25	Digital In Common	-		
26	24V Common ⁽⁵⁾	-	Common for internal power supply.	
27	Digital In 1	Stop - CF	115V AC, 50/60 Hz - Opto isolated Low State: less than 30V AC High State: greater than 100V AC 24V DC - Opto isolated Low State: less than 5V DC High State: greater than 20V DC 11.2 mA DC	361 - 366
28	Digital In 2	Start		
29	Digital In 3	Auto/Man.		
30	Digital In 4	Speed Sel 1		
31	Digital In 5	Speed Sel 2		
32	Digital In 6/Hardware Enable, see pg. -26	Speed Sel 3		
32	Digital In 6/Hardware Enable, see pg. -26	Speed Sel 3		
33	Digital Out 4 – N.C.	Fault	Dedicated fault output - Not user configurable. Relay will energize (pick up) when power is applied to drive and deenergize (drop out) when a fault exists. See Terminals 11-16 for specs.	
34	Digital Out 4 Common			
35	Digital Out 4 – N.O.	NOT Fault		
36	PE			
37	PE			

(1) **Important:** 0-20mA operation requires a jumper at terminals 17 & 18 (or 19 & 20). Drive damage may occur if jumper is not installed.
 (2) These inputs/outputs are dependant on a number of parameters (see "Related Parameters").
 (3) Differential Isolation - External source must be maintained at less than 160V with respect to PE. Input provides high common mode immunity.
 (4) Contacts in unpowered state. Any relay programmed as Fault or Alarm will energize (pick up) when power is applied to drive and deenergize (drop out) when a fault or alarm exists. Relays selected for other functions will energize only when that condition exists and will deenergize when condition is removed.
 (5) 150mA maximum Load. Not present on 115V versions.

Encoder Terminal Block (Vector Control Option Only)

No.	Description (refer to page 65 for encoder specifications)	
8	+12V(1) DC Power	Internal power source
7	+12V(1) DC Return (Common)	250 mA.
6	Encoder Z (NOT)	Pulse, marker or registration input. (2)
5	Encoder Z	
4	Encoder B (NOT)	Quadrature B input.
3	Encoder B	
2	Encoder A (NOT)	Single channel or quadrature A input.
1	Encoder A	

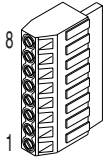

- (1) Jumper selectable +5/12V is available on 20B-ENC-1 Encoder Boards.
- (2) Z channel can be used as a pulse input while A & B are used for encoder.

Sample Encoder Wiring

I/O	Connection Example	I/O	Connection Example
Encoder Power – (1)Internal Drive Power Internal (drive) 12V DC, 250mA		Encoder Power – External Power Source	
Encoder Signal – Single-Ended, Dual Channel		Encoder Signal – Differential, Dual Channel	

(1) SHLD connection is on drive chassis (see page 19).

Hardware Enable Circuitry (Vector Control Option Only)

By default, the user can program a digital input as an Enable input. The status of this input is *interpreted by drive software*. If the application requires the drive to be disabled *without* software interpretation, a “dedicated” hardware enable configuration can be utilized. This is done by removing a jumper and wiring the enable input to “Digital In 6”.

I/O Wiring Examples – Standard & Vector Control Options

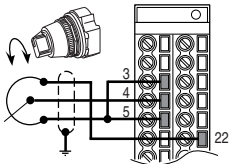
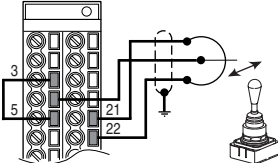
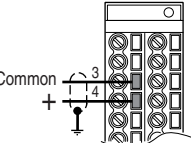
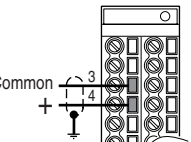
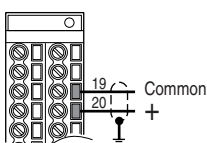
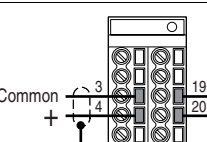
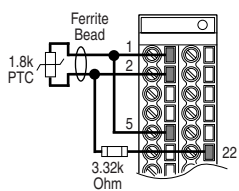
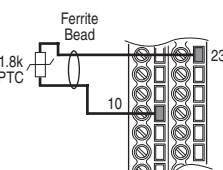
Input/Output	Connection Example	Required Parameter Changes
<p>Potentiometer Unipolar Speed Reference⁽¹⁾ 10k Ohm Pot. Recommended (2k Ohm Minimum)</p>		<ul style="list-style-type: none"> Adjust Scaling: Parameters 91/92 and 325/326 View Results: Parameter 002
<p>Joystick Bipolar Speed Reference⁽¹⁾ ±10V Input</p>		<ul style="list-style-type: none"> Set Direction Mode: Parameter 190 = "1, Bipolar" Adjust Scaling: Parameters 91/92 and 325/326 View Results: Parameter 002
<p>Analog Input Bipolar Speed Reference ±10V Input</p>		<ul style="list-style-type: none"> Set Direction Mode: Parameter 190 = "1, Bipolar" Adjust Scaling: Parameters 91/92 and 325/326 View Results: Parameter 002
<p>Analog Voltage Input Unipolar Speed Reference 0 to +10V Input</p>		<ul style="list-style-type: none"> Configure Input with parameter 320 Adjust Scaling: Parameters 91/92 and 325/326 View results: Parameter 002
<p>Analog Current Input Unipolar Speed Reference Standard 4-20 mA Input</p>		<ul style="list-style-type: none"> Configure Input for Current: Parameter 320, Bit 1 = "1, Current" Adjust Scaling: Parameters 91/92 and 325/326 View Results: Parameter 002
<p>Analog Current Input Unipolar Speed Reference Vector 0-20 mA Input</p>		<ul style="list-style-type: none"> Configure Input for Current: Parameter 320 and add jumper at appropriate terminals Adjust Scaling: Parameters 91/92 and 325/326 View results: Parameter 002
<p>Analog Input, PTC Vector PTC OT set > 5V PTC OT cleared < 4V PTC Short < 0.2V</p>		<ul style="list-style-type: none"> Set Fault Config 1: Parameter 238, bit 7 = "Enabled" Set Alarm Config 1: Parameter 259, bit 11 = "Enabled" View Drive Alarm 1: Parameter 211, bit 11 = "True"
<p>HW PTC Input Series B Only PTC OT set > 5V PTC OT cleared < 4V PTC Short < 0.2V</p>		<ul style="list-style-type: none"> Set Fault Config 1: Parameter 238, bit 13 = "Enabled" Set Alarm Config 1: Parameter 259, bit 18 = "Enabled" View Status: Drive Alarm 1: Parameter 211, bit 18 = "True"

⁽¹⁾ Refer to the PowerFlex 700 User Manual for important bipolar wiring information.

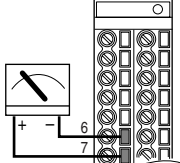
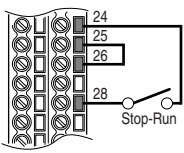
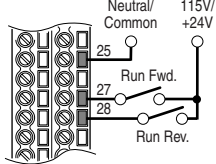
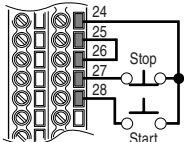
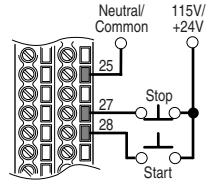
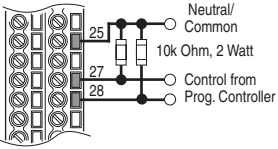
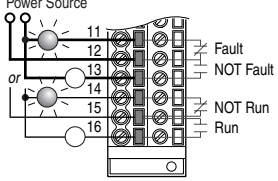
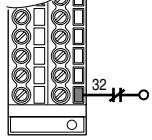
Input/Output	Connection Example	Required Parameter Changes
<p>Analog Output ±10V, 0-20 mA Bipolar +10V Unipolar (shown) <u>Standard Control</u> 4-20 mA Unipolar (use term. 8 & 9)</p>		<ul style="list-style-type: none"> • Configure with Parameter 340 • Select Source Value: Parameter 384, [Digital Out1 Sel] • Adjust Scaling: Parameters 343/344
<p>2-Wire Control Non-Reversing⁽¹⁾ 24V DC internal supply</p>		<ul style="list-style-type: none"> • Disable Digital Input:#1: Parameter 361 = "0, Unused" • Set Digital Input #2: Parameter 362 = "7, Run" • Set Direction Mode: Parameter 190 = "0, Unipolar"
<p>2-Wire Control Reversing⁽¹⁾ External supply (I/O Board dependent)</p>		<ul style="list-style-type: none"> • Set Digital Input:#1: Parameter 361 = "8, Run Forward" • Set Digital Input #2: Parameter 362 = "9, Run Reverse"
<p>3-Wire Control Internal supply</p>		<ul style="list-style-type: none"> • No Changes Required
<p>3-Wire Control External supply (I/O Board dependent). Requires 3-wire functions only ([Digital In1 Sel]). Using 2-wire selections will cause a type 2 alarm.</p>		<ul style="list-style-type: none"> • No Changes Required
<p>Digital Input PLC Output Card (Board dependent).</p>		<ul style="list-style-type: none"> • No Changes Required
<p>Digital Output Relays shown in powered state with drive faulted. See page 24. <u>Standard Control</u> 1 relay at terminals 14-16. <u>Vector Control</u> 2 relays at terminals 14-16.</p>		<ul style="list-style-type: none"> • Select Source to Activate: Parameters 380/384
<p>Enable Input</p>		<ul style="list-style-type: none"> • <u>Standard Control</u> Configure with parameter 366 • <u>Vector Control</u> Configure with parameter 366 For dedicated hardware Enable: Remove Jumper J10 (see page 26)

⁽¹⁾ **Important:** Programming inputs for 2 wire control deactivates all HIM Start buttons.

Cable Recommendations

Cable Types Acceptable for 200-600 Volt Installations

A variety of cable types are acceptable for drive installations. For many installations, unshielded cable is adequate, provided it can be separated from sensitive circuits. As an approximate guide, allow a spacing of 0.3 meters (1 foot) for every 10 meters (32.8 feet) of length. In all cases, long parallel runs must be avoided. Do not use cable with an insulation thickness less than or equal to 15 mils (0.4mm/0.015 in.). Use Copper wire only. Wire gauge requirements and recommendations are based on 75° C. Do not reduce wire gauge when using higher temperature wire. See table below.

Unshielded

THHN, THWN or similar wire is acceptable for drive installation in dry environments provided adequate free air space and/or conduit fill rates limits are provided. **Do not use THHN or similarly coated wire in wet areas.** Any wire chosen must have a minimum insulation thickness of 15 Mil and should not have large variations in insulation concentricity.

Shielded/Armored Cable

Shielded cable contains all of the general benefits of multi-conductor cable with the added benefit of a copper braided shield that can contain much of the noise generated by a typical AC drive. Strong consideration for shielded cable should be given in installations with sensitive equipment such as weigh scales, capacitive proximity switches and other devices that may be affected by electrical noise in the distribution system. Applications with large numbers of drives in a similar location, imposed EMC regulations or a high degree of communications/ networking are also good candidates for shielded cable.

Shielded cable may also help reduce shaft voltage and induced bearing currents for some applications. In addition, the increased impedance of shielded cable may help extend the distance that the motor can be located from the drive without the addition of motor protective devices such as terminator networks. Refer to *Reflected Wave* in “Wiring and Grounding Guidelines for PWM AC Drives,” publication DRIVES-IN001.

Consideration should be given to all of the general specifications dictated by the environment of the installation, including temperature, flexibility, moisture characteristics and chemical resistance. In addition, a braided shield should be included and be specified by the cable manufacturer as having coverage of at least 75%. An additional foil shield can greatly improve noise containment.

A good example of recommended cable is Belden® 295xx (xx determines gauge). This cable has four (4) XLPE insulated conductors with a 100% coverage foil and an 85% coverage copper braided shield (with drain wire) surrounded by a PVC jacket.

Other types of shielded cable are available, but the selection of these types may limit the allowable cable length. Particularly, some of the newer cables twist 4 conductors of THHN wire and wrap them tightly with a foil shield. This construction can greatly increase the cable charging current required and reduce the overall drive performance. Unless specified in the individual distance tables as tested with the drive, these cables are not recommended and their performance against the lead length limits supplied is not known.

Location	Rating/Type	Description
Standard (Option 1)	600V, 90° C (194° F) XHHW2/RHW-2 Anixter B209500-B209507, Belden 29501-29507, or equivalent	<ul style="list-style-type: none"> Four tinned copper conductors with XLP insulation. Copper braid/aluminum foil combination shield and tinned copper drain wire. PVC jacket.
Standard (Option 2)	Tray rated 600V, 90° C (194° F) RHH/RHW-2 Anixter OLF-7xxxxx or equivalent	<ul style="list-style-type: none"> Three tinned copper conductors with XLPE insulation. 5 mil single helical copper tape (25% overlap min.) with three bare copper grounds in contact with shield. PVC jacket.
Class I & II; Division I & II	Tray rated 600V, 90° C (194° F) RHH/RHW-2 Anixter 7V-7xxxx-3G or equivalent	<ul style="list-style-type: none"> Three bare copper conductors with XLPE insulation and impervious corrugated continuously welded aluminum armor. Black sunlight resistant PVC jacket overall. Three copper grounds on #10 AWG and smaller.

Power Ratings and Branch Circuit Protection

208 Volt AC Input Protection Devices (See [page 33](#) for Notes)

Drive Catalog Number	Frame	HP Rating		PWM Freq. kHz	Temp. (1) °C	Input Ratings		Output Amps			Dual Element Time Delay Fuse		Non-Time Delay Fuse		Circuit Breaker (3) Max. (8)	Motor Circuit Protector (4) Max. (8)	140M Motor Protector with Adjustable Current Range (5)(6)			
		ND	HD			Amps	kVA	Cont.	1 Min.	3 Sec.	Min. (1)	Max. (2)	Min. (1)	Max. (2)			Available Catalog Numbers - 140... (7)			
208 Volt AC Input																				
20BB2P2	0	0.5	0.33	4	50	1.9	0.7	2.5	2.8	3.8	3	6	3	10	15	3	M-C2E-B25	M-D8E-B25	-	-
20BB4P2	0	1	0.75	4	50	3.7	1.3	4.8	5.6	7.0	6	10	6	17.5	15	7	M-C2E-B63	M-D8E-B63	-	-
20BB6P8	1	2	1.5	4	50	6.8	2.4	7.8	10.4	13.8	10	15	10	30	30	15	M-C2E-C10	M-D8E-C10	M-F8E-C10	-
20BB9P6	1	3	2	4	50	9.5	3.4	11	12.1	17	12	20	12	40	40	15	M-C2E-C16	M-D8E-C16	M-F8E-C16	-
20BB015	1	5	3	4	50	15.7	5.7	17.5	19.3	26.3	20	35	20	70	70	30	M-C2E-C20	M-D8E-C20	M-F8E-C20	-
20BB022	1	7.5	5	4	50	23.0	8.3	25.3	27.8	38	30	50	30	100	100	30	M-C2E-C25	M-D8E-C25	M-F8E-C25	-CMN-2500
20BB028	2	10	7.5	4	50	29.6	10.7	32.2	38	50.6	40	70	40	125	125	50	-	-	M-F8E-C32	-CMN-4000
20BB042	3	15	10	4	50	44.5	16.0	48.3	53.1	72.5	60	100	60	175	175	70	-	-	M-F8E-C45	-CMN-6300
20BB052	3	20	15	4	50	51.5	17.1	56	64	86	80	125	80	200	200	100	-	-	-	-CMN-6300
20BB070	4	25	20	4	50	72	25.9	78.2	93	124	90	175	90	300	300	100	-	-	-	-CMN-9000
20BB080	4	30	25	4	50	84.7	30.5	92	117	156	110	200	110	350	350	150	-	-	-	-CMN-9000
20BB104 (12)	5	40	-	4	50	113	40.7	120	132	175	150	250	150	475	350	150	-	-	-	-
		-	30	4	50	84.7	30.5	92	138	175	125	200	125	350	300	150	-	-	-	-CMN-9000
20BB130 (12)	5	50	-	4	50	141	44.1	130	143	175	175	275	175	500	375	250	-	-	-	-
		-	40	4	50	113	35.3	104	156	175	125	225	125	400	300	150	-	-	-	-
20BB154 (12)	6	60	-	4	50	167	60.1	177	195	266	225	350	225	500	500	250	-	-	-	-
		-	50	4	50	141	50.9	150	225	300	200	300	200	500	450	250	-	-	-	-
20BB192 (12)	6	75	-	4	50	208	75.0	221	243	308	300	450	300	600	600	400	-	-	-	-
		-	60	4	50	167	60.1	177	266	308	225	350	225	500	500	250	-	-	-	-
20BB260 (12)	6	100	-	2	45	255	91.9	260	286	390	300	575	300	750	750	400	-	-	-	-
		-	75	2	50	199	71.7	205	305	410	225	450	225	600	600	400	-	-	-	-

240 Volt AC Input Protection Devices (See [page 33](#) for Notes)

Drive Catalog Number	Frame	HP Rating		PWM Freq. kHz	Temp. (1) °C	Input Ratings		Output Amps			Dual Element Time Delay Fuse		Non-Time Delay Fuse		Circuit Breaker (3) Max. (8)	Motor Circuit Protector (4) Max. (8)	140M Motor Protector with Adjustable Current Range (5)(6)			
		ND	HD			Amps	kVA	Cont.	1 Min.	3 Sec.	Min. (1)	Max. (2)	Min. (1)	Max. (2)			Available Catalog Numbers - 140... (7)			
240 Volt AC Input																				
20BB2P2	0	0.5	0.33	4	50	1.7	0.7	2.2	2.4	3.3	3	6	3	10	15	3	M-C2E-B25	M-D8E-B25	-	-
20BB4P2	0	1	0.75	4	50	3.3	1.4	4.2	4.8	6.4	5	8	5	15	15	7	M-C2E-B63	M-D8E-B63	-	-
20BB6P8	1	2	1.5	4	50	5.9	2.4	6.8	9	12	10	15	10	25	25	15	M-C2E-C10	M-D8E-C10	M-F8E-C10	-
20BB9P6	1	3	2	4	50	8.3	3.4	9.6	10.6	14.4	12	20	12	35	35	15	M-C2E-C10	M-D8E-C10	M-F8E-C10	-
20BB015	1	5	3	4	50	13.7	5.7	15.3	16.8	23	20	30	20	60	60	30	M-C2E-C16	M-D8E-C16	M-F8E-C16	-
20BB022	1	7.5	5	4	50	19.9	8.3	22	24.2	33	25	50	25	80	80	30	M-C2E-C25	M-D8E-C25	M-F8E-C25	-CMN-2500
20BB028	2	10	7.5	4	50	25.7	10.7	28	33	44	35	60	35	100	100	50	-	-	M-F8E-C32	-CMN-4000
20BB042	3	15	10	4	50	38.5	16.0	42	46.2	63	50	90	50	150	150	50	-	-	M-F8E-C45	-CMN-6300
20BB052	3	20	15	4	50	47.7	19.8	52	63	80	60	100	60	200	200	100	-	-	-	-CMN-6300
20BB070	4	25	20	4	50	64.2	26.7	70	78	105	90	150	90	275	275	100	-	-	-	-CMN-9000
20BB080	4	30	25	4	50	73.2	30.5	80	105	140	100	180	100	300	300	100	-	-	-	-CMN-9000
20BB104 (12)	5	40	-	4	50	98	40.6	104	115	175	125	225	125	400	300	150	-	-	-	-
		-	30	4	50	73	30.5	80	120	160	100	175	100	300	300	100	-	-	-	-CMN-9000
20BB130 (12)	5	50	-	4	50	122	50.7	130	143	175	175	275	175	500	375	250	-	-	-	-
		-	40	4	50	98	40.6	104	156	175	125	225	125	400	300	150	-	-	-	-
20BB154 (12)	6	60	-	4	50	145	60.1	154	169	231	200	300	200	600	450	250	-	-	-	-
		-	50	4	50	122	50.7	130	195	260	175	275	175	500	375	250	-	-	-	-
20BB192 (12)	6	75	-	4	50	180	74.9	192	211	288	225	400	225	600	575	250	-	-	-	-
		-	60	4	50	145	60.1	154	231	308	200	300	200	600	450	250	-	-	-	-
20BB260 (12)	6	100	-	2	45	233	96.7	260	286	390	300	575	300	750	750	300	-	-	-	-
		-	75	2	50	169	70.1	205	305	410	225	450	225	600	600	250	-	-	-	-

400 Volt AC Input Protection Devices (See page 33 for Notes)

Drive Catalog Number	Frame	kW Rating		PWM Freq. kHz	Temp. (T1) °C	Input Ratings		Output Amps			Dual Element Time Delay Fuse		Non-Time Delay Fuse		Circuit Breaker (3)	Motor Circuit Protector (4)	140M Motor Protector with Adjustable Current Range (5)(6)			
		ND	HD			Amps	kVA	Cont.	1 Min.	3 Sec.	Min. (1)	Max. (2)	Min. (1)	Max. (2)			Max. (8)	Available Catalog Numbers - 140...(7)		
400 Volt AC Input																				
20BC1P3	0	0.37	0.25	4	50	1.1	0.77	1.3	1.4	1.9	3	3	3	6	15	3	M-C2E-B16	-	-	-
20BC2P1	0	0.75	0.55	4	50	1.8	1.3	2.1	2.4	3.2	3	6	3	8	15	3	M-C2E-B25	M-D8E-B25	-	-
20BC3P5	0	1.5	0.75	4	50	3.2	2.2	3.5	4.5	6.0	6	7	6	12	15	7	M-C2E-B40	M-D8E-B40	-	-
20BC5P0	0	2.2	1.5	4	50	4.6	3.2	5.0	5.5	7.5	6	10	6	20	20	7	M-C2E-B63	M-D8E-B63	-	-
20BC8P7	0	4	2.2	4	50	7.9	5.5	8.7	9.9	13.2	15	17.5	15	30	30	15	M-C2E-C10	M-D8E-C10	M-F8E-C10	-
20BC011	0	5.5	4	4	50	10.8	7.5	11.5	13	17.4	15	25	15	45	45	15	M-C2E-C16	M-D8E-C16	M-F8E-C16	-
20BC015	1	7.5	5.5	4	50	14.4	10.0	15.4	17.2	23.1	20	30	20	60	60	20	M-C2E-C20	M-D8E-C20	M-F8E-C20	-
20BC022	1	11	7.5	4	50	20.6	14.3	22	24.2	33	30	45	30	80	80	30	M-C2E-C25	M-D8E-C25	M-F8E-C25	-
20BC030	2	15	11	4	50	28.4	19.7	30	33	45	35	60	35	120	120	50	-	-	M-F8E-C32	-
20BC037	2	18.5	15	4	50	35.0	24.3	37	45	60	45	80	45	125	125	50	-	-	M-F8E-C45	-
20BC043	3	22	18.5	4	50	40.7	28.2	43	56	74	60	90	60	150	150	60	-	-	-	-
20BC056	3	30	22	4	50	53.3	36.7	56	64	86	70	125	70	200	200	100	-	-	-	-
20BC072	3	37	30	4	50 ⁽¹⁰⁾	68.9	47.8	72	84	112	90	150	90	250	250	100	-	-	-	-
20BC085 ⁽¹²⁾	4	45	-	4	45	81.4	56.4	85	94	128	110	200	110	300	300	150	-	-	-	-
		-	37	4	45	68.9	47.8	72	108	144	90	175	90	275	300	100	-	-	-	-
20BC105 ⁽¹²⁾	5	55	-	4	50 ⁽⁹⁾	100.5	69.6	105	116	158	125	225	125	400	300	150	-	-	-	-
		-	45	4	50 ⁽⁹⁾	81.4	56.4	85	128	170	110	175	110	300	300	150	-	-	-	-
20BC125 ⁽¹²⁾	5	55	-	4	50 ⁽⁹⁾	121.1	83.9	125	138	163	150	275	150	500	375	250	-	-	-	-
		-	45	4	50 ⁽⁹⁾	91.9	63.7	96	144	168	125	200	125	375	375	150	-	-	-	-
20BC140 ⁽¹²⁾	5	75	-	4	40 ⁽⁹⁾	136	93.9	140	154	190	200	300	200	400	400	250	-	-	-	-
		-	55	4	40 ⁽⁹⁾	101	69.6	105	157	190	150	225	150	300	300	150	-	-	-	-
20BC170 ⁽¹²⁾	6	90	-	4	50 ⁽⁹⁾	164	126	170	187	255	250	375	250	600	500	250	-	-	-	-
		-	75	4	50 ⁽⁹⁾	136	103	140	210	280	200	300	200	550	400	250	-	-	-	-
20BC205 ⁽¹²⁾	6	110	-	4	40 ⁽⁹⁾	199	148	205	220	289	250	450	250	600	600	400	-	-	-	-
		-	90	4	40 ⁽⁹⁾	164	126	170	255	313	250	375	250	600	500	250	-	-	-	-
20BC260 ⁽¹²⁾	6	132	-	2	45 ⁽⁹⁾	255	177	260	286	390	350	550	350	750	750	400	-	-	-	-
		-	110	2	50 ⁽⁹⁾	199	138	205	308	410	250	450	250	600	600	400	-	-	-	-
20BC292	7	160	-	4	40	293	203	292	322	438	375	650	375	850	850	400	-	-	-	-
		-	150	4	40	264	183	263	395	526	350	550	350	550	750	400	-	-	-	-
20BC325	7	180	-	4	40	326	226	325	358	488	425	700	425	950	950	600	-	-	-	-
		-	180	4	40	326	226	325	488	650	425	700	425	950	950	600	-	-	-	-
20BC365	8	200	-	2	40	366	253	365	402	548	475	800	475	1000	1000	600	-	-	-	-
		-	180	2	40	326	226	325	488	650	425	700	425	950	950	600	-	-	-	-
20BC415	8	240	-	2	40	416	288	415	457	623	525	900	525	1200	1200	600	-	-	-	-
		-	200	2	40	366	253	365	548	730	475	800	475	1000	1000	600	-	-	-	-
20BC481	8	280	-	2	40	483	334	481	530	722	600	1000	600	1400	1400	700	-	-	-	-
		-	240	2	40	416	288	415	623	830	525	900	525	1200	1200	600	-	-	-	-
20BC535	8	300	-	2	40	537	372	535	589	803	700	1200	700	1600	1600	700	-	-	-	-
		-	280	2	40	483	334	481	722	962	600	1000	600	1400	1400	700	-	-	-	-
20BC600	8	350	-	2	40	602	417	600	660	900	750	1300	750	1800	1800	800	-	-	-	-
		-	300	2	40	537	371	535	803	1070	700	1200	700	1600	1600	700	-	-	-	-
20BC700	9	400	-	2	40	702	486	700	770	1050	900	1500	900	2100	2100	900	-	-	-	-
		-	350	2	40	702	417	600	900	1200	750	1300	750	1800	1800	800	-	-	-	-
20BC875	10	500	-	2	40	877	608	875	963	1313	1100	1900	1100	2600	2600	1200	-	-	-	-
		-	400	2	40	877	486	700	1050	1400	900	1500	900	2100	2100	900	-	-	-	-

480 Volt AC Input Protection Devices (See page 33 for Notes)

Drive Catalog Number	Frame	HP Rating		PWM Freq. kHz	Temp. (11) °C	Input Ratings		Output Amps			Dual Element Time Delay Fuse		Non-Time Delay Fuse		Circuit Breaker (3)	Motor Circuit Protector (4)	140M Motor Protector with Adjustable Current Range (5)(6)			
		ND	HD			Amps	kVA	Cont.	1 Min.	3 Sec.	Min. (1)	Max. (2)	Min. (1)	Max. (2)			Max. (8)	Available Catalog Numbers - 140... (7)		
480 Volt AC Input																				
20BD1P1	0	0.5	0.33	4	50	0.9	0.7	1.1	1.2	1.6	3	3	3	6	15	3	M-C2E-B16	-	-	-
20BD2P1	0	1	0.75	4	50	1.6	1.4	2.1	2.4	3.2	3	6	3	8	15	3	M-C2E-B25	-	-	-
20BD3P4	0	2	1.5	4	50	2.6	2.2	3.4	4.5	6.0	4	8	4	12	15	7	M-C2E-B40	M-D8E-B40	-	-
20BD5P0	0	3	2	4	50	3.9	3.2	5.0	5.5	7.5	6	10	6	20	20	7	M-C2E-B63	M-D8E-B63	-	-
20BD8P0	0	5	3	4	50	6.9	5.7	8.0	8.8	12	10	15	10	30	30	15	M-C2E-C10	M-D8E-C10	M-F8E-C10	-
20BD011	0	7.5	5	4	50	9.5	7.9	11	12.1	16.5	15	20	15	40	40	15	M-C2E-C16	M-D8E-C16	M-F8E-C16	-
20BD014	1	10	7.5	4	50	12.5	10.4	14	16.5	22	17.5	30	17.5	50	50	20	M-C2E-C16	M-D8E-C16	M-F8E-C16	-
20BD022	1	15	10	4	50	19.9	16.6	22	24.2	33	25	50	25	80	80	30	M-C2E-C25	M-D8E-C25	M-F8E-C25	-CMN-2500
20BD027	2	20	15	4	50	24.8	20.6	27	33	44	35	60	35	100	100	50	-	-	M-F8E-C32	-CMN-4000
20BD034	2	25	20	4	50	31.2	25.9	34	40.5	54	40	70	40	125	125	50	-	-	M-F8E-C45	-CMN-4000
20BD040	3	30	25	4	50	36.7	30.5	40	51	68	50	90	50	150	150	50	-	-	M-F8E-C45	-CMN-4000
20BD052	3	40	30	4	50	47.7	39.7	52	60	80	60	110	60	200	200	70	-	-	-	-CMN-6300
20BD065	3	50	40	4	50	59.6	49.6	65	78	104	80	125	80	250	250	100	-	-	-	-CMN-9000
20BD077 (12)	4	60	-	4	50	72.3	60.1	77	85	116	100	170	100	300	300	100	-	-	-	-CMN-9000
20BD096 (12)	5	75	-	4	50(9)	90.1	74.9	96	106	144	125	200	125	350	350	125	-	-	-	-
			60	4	50(9)	72.3	60.1	77	116	154	100	170	100	300	300	100	-	-	-	-CMN-9000
20BD125 (12)	5	100	-	4	50(9)	117	97.6	125	138	163	150	250	150	500	375	150	-	-	-	-
			75	4	50(9)	90.1	74.9	96	144	168	125	200	125	350	350	125	-	-	-	-
20BD156 (12)	6	125	-	4	50(9)	147	122	156	172	234	200	350	200	600	450	250	-	-	-	-
			100	4	50(9)	131	109	125	188	250	175	250	175	500	375	250	-	-	-	-
20BD180 (12)	6	150	-	4	50(9)	169	141	180	198	270	225	400	225	600	500	250	-	-	-	-
			125	4	50(9)	147	122	156	234	312	200	350	200	600	450	250	-	-	-	-
20BD248 (12)	6	200	-	2	45(9)	233	194	248	273	372	300	550	300	700	700	400	-	-	-	-
			150	2	50(9)	169	141	180	270	360	225	400	225	600	500	250	-	-	-	-
20BD292	7	250	-	4	40	281	233	292	322	438	375	650	375	850	850	400	-	-	-	-
			200	4	40	253	210	263	395	526	350	550	350	550	750	400	-	-	-	-
20BD325	7	250	-	4	40	313	260	325	358	488	425	700	425	950	950	600	-	-	-	-
			250	4	40	313	260	325	488	650	425	700	425	950	950	600	-	-	-	-
20BD365	8	300	-	2	40	351	292	365	402	548	475	800	475	1000	1000	600	-	-	-	-
			250	2	40	313	260	325	488	650	425	700	425	950	950	600	-	-	-	-
20BD415	8	350	-	2	40	399	331	415	457	623	525	900	525	1200	1200	600	-	-	-	-
			300	2	40	351	291	365	548	730	475	800	475	1000	1000	600	-	-	-	-
20BD481	8	400	-	2	40	462	384	481	530	722	600	1000	600	1400	1400	700	-	-	-	-
			350	2	40	399	331	415	623	830	525	900	525	1200	1200	600	-	-	-	-
20BD535	8	450	-	2	40	514	427	535	589	803	700	1200	700	1600	1600	700	-	-	-	-
			400	2	40	462	384	481	722	962	600	1000	600	1400	1400	700	-	-	-	-
20BD600	8	500	-	2	40	577	479	600	660	900	750	1300	750	1800	1800	800	-	-	-	-
			450	2	40	514	427	535	803	1070	700	1200	700	1600	1600	700	-	-	-	-
20BD700	9	600	-	2	40	673	559	700	770	1050	900	1500	900	2100	2100	900	-	-	-	-
			500	2	40	577	479	600	900	1200	750	1300	750	1800	1800	800	-	-	-	-
20BD875	10	700	-	2	40	841	699	875	963	1313	1100	1900	1100	2600	2600	1200	-	-	-	-
			600	2	40	673	559	700	1050	1400	900	1500	900	2100	2100	900	-	-	-	-

600 Volt AC Input Protection Devices

Drive Catalog Number	Frame	HP Rating		PWM Freq. kHz	Temp. (11) °C	Input Ratings		Output Amps			Dual Element Time Delay Fuse		Non-Time Delay Fuse		Circuit Breaker (3) Max. (8)	Motor Circuit Protector (4) Max. (8)	140M Motor Protector with Adjustable Current Range (5)(6) Available Catalog Numbers - 140... (7)			
		ND	HD			Amps	kVA	Cont.	1 Min.	3 Sec.	Min. (1)	Max. (2)	Min. (1)	Max. (2)			M-C2E-B16	M-D8E-B40	M-F8E-C10	
600 Volt AC Input																				
20BE1P7	0	1	0.5	4	50	1.3	1.4	1.7	2	2.6	2	4	2	6	15	3	M-C2E-B16	-	-	-
20BE2P7	0	2	1	4	50	2.1	2.1	2.7	3.6	4.8	3	6	3	10	15	3	M-C2E-B25	-	-	-
20BE3P9	0	3	2	4	50	3.0	3.1	3.9	4.3	5.9	6	9	6	15	15	7	M-C2E-B40	M-D8E-B40	-	-
20BE6P1	0	5	3	4	50	5.3	5.5	6.1	6.7	9.2	9	12	9	20	20	15	M-C2E-B63	M-D8E-B63	-	-
20BE9P0	0	7.5	5	4	50	7.8	8.1	9	9.9	13.5	10	20	10	35	30	15	M-C2E-C10	M-D8E-C10	M-F8E-C10	-
20BE011	1	10	7.5	4	50	9.9	10.2	11	13.5	18	15	25	15	40	40	15	M-C2E-C10	M-D8E-C10	M-F8E-C10	-
20BE017	1	15	10	4	50	15.4	16.0	17	18.7	25.5	20	40	20	60	50	20	M-C2E-C16	M-D8E-C16	M-F8E-C16	-
20BE022	2	20	15	4	50	20.2	21.0	22	25.5	34	30	50	30	80	80	30	M-C2E-C25	M-D8E-C25	M-F8E-C25	-CMN-2500
20BE027	2	25	20	4	50	24.8	25.7	27	33	44	35	60	35	100	100	50	-	-	M-F8E-C25	-CMN-2500
20BE032	3	30	25	4	50	29.4	30.5	32	40.5	54	40	70	40	125	125	50	-	-	M-F8E-C32	-CMN-4000
20BE041	3	40	30	4	50	37.6	39.1	41	48	64	50	90	50	150	150	100	-	-	M-F8E-C45	-CMN-4000
20BE052	3	50	40	4	50	47.7	49.6	52	61.5	82	60	110	60	200	200	100	-	-	-	-CMN-6300
20BE062	4	60	50	2	50	58.2	60.5	62	78	104	80	125	80	225	225	100	-	-	-	-CMN-6300
20BE077 (12)	5	75	-	2	50(9)	72.3	75.1	77	85	116	90	150	90	300	300	100	-	-	-	-CMN-9000
		-	60	2	50(9)	58.2	60.5	63	94	126	90	125	90	250	250	100	-	-	-	-CMN-6300
20BE099 (12)	5	100	-	2	40(9)	92.9	96.6	99	109	126	125	200	125	375	375	150	-	-	-	-
		-	75	2	40(9)	72.3	75.1	77	116	138	100	175	100	300	300	100	-	-	-	-CMN-9000
20BE125 (12)	6	125	-	2	50(9)	117	122	125	138	188	150	250	150	375	375	250	-	-	-	-
		-	100	2	50(9)	93	96.6	99	149	198	125	200	125	375	375	150	-	-	-	-
20BE144 (12)	6	150	-	2	50(9)	135	141	144	158	216	175	300	175	400	400	250	-	-	-	-
		-	125	2	50(9)	117	122	125	188	250	150	275	150	375	375	250	-	-	-	-

690 Volt AC Input Protection Devices (13)

Drive Catalog Number	Frame	kW Rating		PWM Freq. kHz	Temp. (11) °C	Input Ratings		Output Amps			Dual Element Time Delay Fuse		Non-Time Delay Fuse		Circuit Breaker (3) Max. (8)	Motor Circuit Protector (4) Max. (8)
		ND	HD			Amps	kVA	Cont.	1 Min.	3 Sec.	Min. (1)	Max. (2)	Min. (1)	Max. (2)		
690 Volt AC Input																
20BF052 (12)	5	45	-	4	50(9)	46.9	56.1	52	57	78	60	110	60	175	175	-
		-	37.5	4	50(9)	40.1	48.0	46	69	92	50	90	50	150	150	-
20BF060 (12)	5	55	-	4	50(9)	57.7	68.9	60	66	90	80	125	80	225	225	-
		-	45	4	50(9)	46.9	56.1	52	78	104	60	110	60	175	175	-
20BF082 (12)	5	75	-	2	50(9)	79.0	94.4	82	90	123	100	200	100	375	375	-
		-	55	2	50(9)	57.7	68.9	60	90	120	80	125	80	225	225	-
20BF098 (12)	5	90	-	2	40(9)	94.7	113	98	108	127	125	200	125	375	375	-
		-	75	2	40(9)	79.0	94.4	82	123	140	100	200	100	375	375	-
20BF119 (12)	6	110	-	2	50(9)	115	137	119	131	179	150	250	150	400	-	-
		-	90	2	50(9)	94.7	113	98	147	196	125	200	125	375	-	-
20BF142 (12)	6	132	-	2	50(9)	138	165	142	156	213	175	300	175	450	-	-
		-	110	2	50(9)	115	137	119	179	238	150	250	150	400	-	-

Notes:

- (1) Minimum protection device size is the lowest rated device that supplies maximum protection without nuisance tripping.
- (2) Maximum protection device size is the highest rated device that supplies drive protection. For US NEC, minimum size is 125% of motor FLA. Ratings shown are maximum.
- (3) Circuit Breaker - inverse time breaker. For US NEC, minimum size is 125% of motor FLA. Ratings shown are maximum.
- (4) Motor Circuit Protector - instantaneous trip circuit breaker. For US NEC minimum size is 125% of motor FLA. Ratings shown are maximum.
- (5) Bulletin 140M with adjustable current range should have the current trip set to the minimum range that the device will not trip.
- (6) Manual Self-Protected (Type E) Combination Motor Controller, UL listed for 208 Wye or Delta, 240 Wye or Delta, 480Y/277 or 600Y/ 347. Not UL listed for use on 480V or 600V Delta/Delta systems.
- (7) The AIC ratings of the Bulletin 140M Motor Protector may vary. See publication 140M-SG001B-EN-P.
- (8) Maximum allowable rating by US NEC. Exact size must be chosen for each installation.
- (9) UL Type 12/IP54 (flange mount) heat sink ambient temperature rating is 40° C/ambient of unprotected drive portion (inside enclosure) is 55° C. The ambient temperature for the UL Type 12/ IP54 stand-alone drives is 40° C.
- (10) Must remove top label and vent plate, drive enclosure rating will be IP00, NEMA/UL Type Open.
- (11) Drive frames 0-4 temperature rating is for NEMA/UL Type Open. The adhesive top label must be removed to operate drive at this temperature. Frames 5 & 6 do not have a top label.
- (12) Drives have dual current ratings; one for normal duty applications, and one for heavy duty applications. The drive may be operated at either rating.
- (13) CE certification testing has not been performed on Frame 7-10 drives.

325 Volt DC Input Protection Devices (See page 36 for Notes)

Drive Catalog Number	Frame	HP Rating		PWM Freq. kHz	Temp. (1) °C	DC Input Ratings Amps	Output Amps			Fuse	Non-Time Delay Fuse (2)
		ND	HD				Cont.	1 Min.	3 Sec.		
325 Volt DC Input											
20BB2P2	0	0.5	0.33	4	50	2.0	2.2	2.4	3.3	5	JKS-5
20BB4P2	0	1	0.75	4	50	3.8	4.2	4.8	6.4	10	JKS-10
20BB6P8	1	2	1.5	4	50	6.9	6.8	9	12	15	HSJ15
20BB9P6	1	3	2	4	50	9.7	9.6	10.6	14.4	20	HSJ20
20BB015	1	5	3	4	50	16	15.3	16.8	23.0	30	HSJ30
20BB022	1	7.5	5	4	50	23.3	22	24.2	33	45	HSJ45
20BB028	2	10	7.5	4	50	30	28	33	44	60	HSJ60
20BB042	3	15	10	4	50	45	42	46.2	63	90	HSJ90
20BB052	3	20	15	4	50	55	52	63	80	100	HSJ100
20BB074	4	25	20	4	50	75.3	70	78	105	150	HSJ150
20BB080	4	30	25	4	50	86.8	80	105	140	175	HSJ175
20BN104 (3)	5	40	–	4	50	114.1	104	115	175	225	HSJ225
		–	30	4	50	85.8	80	120	160	225	HSJ225
20BN130 (3)	5	50	–	4	50	142.6	130	143	175	250	HSJ250
		–	40	4	50	114.1	104	156	175	250	HSJ250
20BN154 (3)	6	60	–	4	50	169	154	169	231	300	HSJ300
		–	50	4	50	142.6	130	195	260	300	HSJ300
20BN192 (3)	6	75	–	4	50	210.6	192	211	288	400	HSJ400
		–	60	4	50	169	154	231	308	400	HSJ400
20BN260 (3)	6	100	–	2	45	285.3	260	286	390	400	HSJ400
		–	75	2	50	210.6	205	305	410	400	HSJ400

540 Volt DC Input Protection Devices (See page 36 for Notes)

Drive Catalog Number	Frame	kW Rating		PWM Freq. kHz	Temp. (1) °C	DC Input Ratings Amps kW	Output Amps			Fuse	Non-Time Delay Fuse (2)	
		ND	HD				Cont.	1 Min.	3 Sec.			
540 Volt DC Input												
20BC1P3	0	0.37	0.25	4	50	1.3	1.3	1.4	1.9	3	JKS-3	
20BC2P1	0	0.75	0.55	4	50	2.1	2.1	2.4	3.2	6	JKS-6	
20BC3P5	0	1.5	0.75	4	50	3.7	3.5	4.5	6.0	8	JKS-8	
20BC5P0	0	2.2	1.5	4	50	5.3	5.0	5.5	7.5	10	JKS-10	
20BC8P7	0	4	3.0	4	50	9.3	8.7	9.9	13.2	15	HSJ15	
20BC011	0	5.5	4	4	50	12.6	11.5	13	17.4	20	HSJ20	
20BC015	1	7.5	5.5	4	50	16.8	15.4	17.2	23.1	25	HSJ25	
20BC022	1	11	7.5	4	50	24	22	24.2	33	40	HSJ40	
20BC030	2	15	11	4	50	33.2	30	33	45	50	HSJ50	
20BC037	2	18.5	15	4	50	40.9	37	45	60	70	HSJ70	
20BC043	3	22	18.5	4	50	47.5	43	56	74	90	HSJ90	
20BC056	3	30	22	4	50	61.9	56	64	86	100	HSJ100	
20BC072	3	37	30	4	50(7)	80.5	72	84	112	125	HSJ125	
20BC085 (3)(5)	4	45	–	4	45	95.1	85	94	128	150	HSJ150	
		–	37	4	45	80.5	72	108	144	150	HSJ150	
20BH105 (3)(5)	5	55	–	4	50(4)	120.2	105	116	158	175	HSJ175	
		–	45	4	50(4)	95.1	85	128	170	175	HSJ175	
20BH140 (3)(5)	5	75	–	4	40(4)	159	140	154	190	250	HSJ250	
		–	55	4	40(4)	120.2	105	158	190	250	HSJ250	
20BH170 (3)(5)	6	90	–	4	50(4)	192.3	170	187	255	350	HSJ350	
		–	75	4	50(4)	159	140	210	280	350	HSJ350	
20BH205 (3)(5)	6	110	–	4	40(4)	226	205	220	289	350	HSJ350	
		–	90	4	40(4)	192.3	170	255	313	350	HSJ350	
20BH260 (3)(5)	6	132	–	2	45(4)	298	260	286	390	400	HSJ400	
		–	110	2	50(4)	226	205	305	410	400	HSJ400	
20BP292	7	160	–	4	40	342	185	292	322	438	630	Bussmann 170M6608
		–	150	4	40	309	166	263	395	526	630	Bussmann 170M6608
20BP325	7	180	–	4	40	381	206	325	358	488	800	Bussmann 170M6612
		–	180	4	40	381	206	325	488	650	800	Bussmann 170M6612
20BP365	8	200	–	2	40	428	231	365	402	548	800	Bussmann 170M6612
		–	180	2	40	381	206	325	488	650	800	Bussmann 170M6612
20BP415	8	240	–	2	40	487	262	415	457	623	800	Bussmann 170M6612
		–	200	2	40	428	231	365	548	730	800	Bussmann 170M6612

Drive Catalog Number	Frame	kW Rating		PWM Freq. kHz	Temp. (1) °C	DC Input Ratings		Output Amps			Fuse	Non-Time Delay Fuse (2)
		ND	HD			Amps	kW	Cont.	1 Min.	3 Sec.		
20BP481	8	280		2	40	564	304	481	530	722	900	Bussmann 170M6613
			240	2	40	487	262	415	623	830	900	Bussmann 170M6613
20BP535	8	300		2	40	627	338	535	589	803	1000	Bussmann 170M6614
			280	2	40	564	304	481	722	962	1000	Bussmann 170M6614
20BP600	8	350		2	40	703	379	600	660	900	1200 ⁽⁸⁾	Bussmann 170M6616
			300	2	40	627	338	535	803	1070	1200 ⁽⁸⁾	Bussmann 170M6616
20BP700	9	400		2	40	820	443	700	770	1050	1400 ⁽⁹⁾	Bussmann 170M6617
			350	2	40	703	379	600	900	1200	1400 ⁽⁹⁾	Bussmann 170M6617
20BH875 No Precharge	10	500		2	40	1025	553	875	963	1313	2 x 800	Bussmann 170M6612
			400	2	40	820	443	700	1050	1400	2 x 800	Bussmann 170M6612

650 Volt DC Input Protection Devices (See page 36 for Notes)

Drive Catalog Number	Frame	HP Rating		PWM Freq. kHz	Temp. (1) °C	DC Input Ratings		Output Amps			Fuse	Non-Time Delay Fuse (2)
		ND	HD			Amps	kW	Cont.	1 Min.	3 Sec.		
650 Volt DC Input												
20BD1P1	0	0.5	0.33	4	50	1.0		1.1	1.2	1.6	3	JKS-3
20BD2P1	0	1	0.75	4	50	1.9		2.1	2.4	3.2	6	JKS-6
20BD3P4	0	2	1.5	4	50	3.0		3.4	4.5	6.0	6	JKS-6
20BD5P0	0	3	2	4	50	4.5		5.0	5.5	7.5	10	JKS-10
20BD8P0	0	5	3	4	50	8.1		8.0	8.8	12	15	HSJ15
20BD011	0	7.5	5	4	50	11.1		11	12.1	16.5	20	HSJ20
20BD014	1	10	7.5	4	50	14.7		14	16.5	22	30	HSJ30
20BD022	1	15	10	4	50	23.3		22	24.2	33	40	HSJ40
20BD027	2	20	15	4	50	28.9		27	33	44	50	HSJ50
20BD034	2	25	20	4	50	36.4		34	40.5	54	60	HSJ60
20BD040	3	30	25	4	50	42.9		40	51	68	80	HSJ80
20BD052	3	40	30	4	50	55.7		52	60	80	90	HSJ90
20BD065	3	50	40	4	50	69.7		65	78	104	100	HSJ100
20BD077 ⁽³⁾	4	60	-	4	50	84.5		77	85	116	150	HSJ150
		-	50	4	50	69.7		65	98	130	150	HSJ150
20BR096 ⁽³⁾⁽⁶⁾	5	75	-	4	50 ⁽⁴⁾	105.3		96	106	144	175	HSJ175
		-	60	4	50 ⁽⁴⁾	84.5		77	116	154	175	HSJ175
20BR125 ⁽³⁾⁽⁶⁾	5	100	-	4	50 ⁽⁴⁾	137.1		125	138	163	200	HSJ200
		-	75	4	50 ⁽⁴⁾	105.3		96	144	168	200	HSJ200
20BR156 ⁽³⁾⁽⁶⁾	6	125	-	4	50 ⁽⁴⁾	171.2		156	172	234	300	HSJ300
		-	100	4	50 ⁽⁴⁾	137.1		125	188	250	300	HSJ300
20BR180 ⁽³⁾⁽⁶⁾	6	150	-	4	50 ⁽⁴⁾	204		180	198	270	400	HSJ400
		-	125	4	50 ⁽⁴⁾	171.2		156	234	312	400	HSJ400
20BR248 ⁽³⁾⁽⁶⁾	6	200	-	2	45 ⁽⁴⁾	272		248	273	372	400	HSJ400
		-	150	2	50 ⁽⁴⁾	204		180	270	360	400	HSJ400
20BR292	7	250		4	40	328	212	292	322	438	630	Bussmann 170M6608
			200	4	40	296	191	263	395	526	630	Bussmann 170M6608
20BR325	7	250		4	40	365	236	325	358	488	800	Bussmann 170M6612
			250	4	40	365	236	325	488	650	800	Bussmann 170M6612
20BR365	8	300		2	40	410	265	365	402	548	800	Bussmann 170M6612
			250	2	40	365	236	325	488	650	800	Bussmann 170M6612
20BR415	8	350		2	40	466	302	415	457	623	800	Bussmann 170M6612
			300	2	40	410	265	365	548	730	800	Bussmann 170M6612
20BR481	8	400		2	40	540	350	481	530	722	900	Bussmann 170M6613
			350	2	40	466	302	415	623	830	900	Bussmann 170M6613
20BR535	8	450		2	40	601	389	535	589	803	1000	Bussmann 170M6614
			400	2	40	540	350	481	722	962	1000	Bussmann 170M6614
20BR600	8	500		2	40	674	436	600	660	900	1200 ⁽⁸⁾	Bussmann 170M6616
			450	2	40	601	389	535	803	1070	1200 ⁽⁸⁾	Bussmann 170M6616
20BR700	9	600		2	40	786	509	700	770	1050	1400 ⁽⁹⁾	Bussmann 170M6617
			500	2	40	674	436	600	900	1200	1400 ⁽⁹⁾	Bussmann 170M6617
20BJ875 No Precharge	10	700		2	40	983	636	875	963	1313	2 x 800	Bussmann 170M6612
			600	2	40	786	509	700	1050	1400	2 x 800	Bussmann 170M6612

810 Volt DC Input Protection Devices

Drive Catalog Number	Frame	HP Rating		PWM Freq.	Temp. (1)	DC Input Ratings	Output Amps			Fuse	Non-Time Delay Fuse (2)
		ND	HD	kHz	°C	Amps	Cont.	1 Min.	3 Sec.		
810 Volt DC Input											
20BE1P7	0	1	0.75	4	50	1.5	1.7	2	2.6	3	JKS-3
20BE2P7	0	2	1.5	4	50	2.4	2.7	3.6	4.8	6	JKS-6
20BE3P9	0	3	2	4	50	3.5	3.9	4.3	5.9	6	JKS-6
20BE6P1	0	5	3	4	50	6.2	6.1	6.7	9.2	10	JKS-10
20BE9P0	0	7.5	5	4	50	9.1	9	9.9	13.5	15	HSJ15
20BE011	0	10	7.5	4	50	11.5	11	13.5	18	20	HSJ20
20BE017	1	15	10	4	50	18	17	18.7	25.5	30	HSJ30
20BE022	2	20	15	4	50	23.6	22	25.5	34	40	HSJ40
20BE027	2	25	20	4	50	29	27	33	44	50	HSJ50
20BE032	3	30	25	4	50	34.3	32	40.5	54	60	HSJ60
20BE041	3	40	30	4	50	43.9	41	48	64	70	HSJ70
20BE052	3	50	40	4	50	55.7	52	61.5	82	90	HSJ90
20BE062	4	60	50	2	50	68.0	62	78	104	125	HSJ125
20BT099(3)	5	100	–	2	40	108.6	99	109	126	150	HSJ150
		–	75	2	40	84.5	77	116	138	150	HSJ150
20BT144(3)	6	150	–	2	50	158	144	158	216	200	HSJ200
		–	125	2	50	137.1	125	188	250	200	HSJ200

932 Volt DC Input Protection Devices

Drive Catalog Number	Frame	kW Rating		PWM Freq.	Temp. (1)	DC Input Ratings	Output Amps			Fuse	Non-Time Delay Fuse (2)
		ND	HD	kHz	°C	Amps	Cont.	1 Min.	3 Sec.		
932 Volt DC Input											
20BW052(3)	5	45	–	2	50(4)	58.2	52	57	78	100	170M3741
		–	37.5	2	50(4)	46.9	46	69	92	100	170M3741
20BW098(3)	5	90	–	2	50(4)	110.7	98	108	127	160	HSJ160
		–	75	2	50(4)	92.3	82	123	140	160	HSJ160
20BW142(3)	6	132	–	2	50(4)	162.2	142	156	213	250	HSJ250
		–	110	2	40(4)	134.9	119	179	238	250	HSJ250

Notes

- (1) Drive frames 0-4 temperature rating is for NEMA/UL Type Open. The adhesive top label must be removed to operate drive at this temperature. Frames 5 & 6 do not have a top label.
- (2) The power source to Common Bus inverters must be derived from AC voltages 600V or less, as defined in NFPA70; Art 430-18 (NEC). Battery supplies or MG sets are not included. The following devices were validated to break current of the derived power DC Bus.
Disconnects: Allen-Bradley Bulletin No. 1494, 30-400A; 194, 30-400A; or ABB OESA, 600 & 800A; OESL, all sizes.
Fuses: Bussmann Type JKS, all sizes; Type 170M, Case Sizes 1, 2 and 3, or Ferraz Shawmut Type HSJ, all sizes. For any other devices, please contact the factory.
- (3) Drives have dual current ratings; one for normal duty applications, and one for heavy duty applications. The drive may be operated at either rating.
- (4) UL Type 12/IP54 (flange mount) heat sink ambient temperature rating is 40° C/ambient of unprotected drive portion (inside enclosure) is 55° C. The ambient temperature for the UL Type 12/IP54 stand-alone drives is 40° C.
- (5) Also applies to "P" voltage class.
- (6) Also applies to "J" voltage class.
- (7) Must remove top label and vent plate, drive enclosure rating will be IP00, NEMA/UL Type Open.
- (8) Two 630A Bussmann 170M6608 can also be used.
- (9) Two 700A Bussmann 170M6611 can also be used.

Maximum Motor Cable Lengths

In the following tables, a “●” in any of the latter columns will indicate that this drive rating can be used with an Allen-Bradley Terminator (1204-TFA1/1204-TFB2) and/or Reflected Wave Reduction Device with Common Mode Choke (1204-RWC-17) or without choke (1204-RWR2).

- For the Terminator, the maximum cable length is 182.9 meters (600 feet) for 400/480/600V drives (not 690V). The PWM frequency must be 2 kHz. The 1204-TFA1 can be used only on low HP (5 HP & below), while the 1204-TFB2 can be used from 2-800 HP.
- 1204 Reflected Wave Reduction Device (all motor insulation classes):
 - 1204-RWR2-09
 - 2 kHz: 182.9m (600 ft.) at 400/480V and 121.9m (400 ft.) at 600V.
 - 4 kHz: 91.4m (300 ft.) at 400/480V and 61.0m (200 ft.) at 600V.
 - 1204-RWC-17
 - 2 kHz: 365.8m (1200 ft.) at 400/480/600V.
 - 4 kHz: 243.8m (800 ft.) at 400/480V and 121.9m (400 ft.) at 600V.

For both devices, power dissipation in the damping resistor limits maximum cable length.

The 1321-RWR is a complete reflected wave reduction solution available for many of the PowerFlex drives. If available, a 1321-RWR catalog number will be indicated in the “Reactor/RWR” column. When not available, use the reactor and resistor information provided to build a solution.

For Further Information on ...	see Publication ...
1321-RWR	1321-TD001
1204-RWR2	1204-5.1
1204-RWC	1204-IN001
1204-TFxx	1204-IN002

PowerFlex 700 (Standard/Vector), 400V Shielded/Unshielded Cable - Meters (Feet)

Frame	Rating		No Solution				Reactor Only				Reactor + Damping Resistor or 1321-RWR				Reactor/RWR	Resistor		Available Options				
	kW	kHz	1000V	1200V	1488V	1600V	1000V	1200V	1488V	1600V	1000V	1200V	1488V	1600V		Cat. No.	Ohms	Watts	TFA1	TFB2	RWR2	RWC
0	0.37	2	7.6 (25)	53.3 (175)	53.3 (175)	53.3 (175)	91.4 (300)	121.9 (400)	121.9 (400)	121.9 (400)	121.9 (400)	121.9 (400)	121.9 (400)	121.9 (400)				●		●	●	
		4	7.6 (25)	53.3 (175)	53.3 (175)	53.3 (175)	18.3 (60)	91.4 (300)	121.9 (400)	121.9 (400)	121.9 (400)	121.9 (400)	121.9 (400)	121.9 (400)						●	●	
	0.75	2	7.6 (25)	83.8 (275)	83.8 (275)	83.8 (275)	91.4 (300)	152.4 (500)	152.4 (500)	152.4 (500)	152.4 (500)	152.4 (500)	152.4 (500)	152.4 (500)				●		●	●	
		4	7.6 (25)	76.2 (250)	76.2 (250)	76.2 (250)	18.3 (60)	91.4 (300)	152.4 (500)	152.4 (500)	152.4 (500)	152.4 (500)	152.4 (500)	152.4 (500)						●	●	
	1.5	2	7.6 (25)	83.8 (275)	83.8 (275)	83.8 (275)	91.4 (300)	182.9 (600)	182.9 (600)	182.9 (600)	182.9 (600)	182.9 (600)	182.9 (600)	182.9 (600)				●	●	●	●	
		4	7.6 (25)	76.2 (250)	76.2 (250)	76.2 (250)	18.3 (60)	91.4 (300)	182.9 (600)	182.9 (600)	182.9 (600)	182.9 (600)	182.9 (600)	182.9 (600)						●	●	
	2.2	2	7.6 (25)	137.2 (450)	182.9 (600)	182.9 (600)	91.4 (300)	182.9 (600)	182.9 (600)	182.9 (600)	182.9 (600)	182.9 (600)	182.9 (600)	182.9 (600)				●	●	●	●	
		4	7.6 (25)	91.4 (300)	152.4 (500)	182.9 (600)	18.3 (60)	91.4 (300)	182.9 (600)	182.9 (600)	182.9 (600)	182.9 (600)	182.9 (600)	182.9 (600)						●	●	
	4	2	7.6 (25)	137.2 (450)	243.8 (800)	243.8 (800)	91.4 (300)	243.8 (800)	243.8 (800)	243.8 (800)	243.8 (800)	243.8 (800)	243.8 (800)	243.8 (800)	1321-RWR8-DP					●		●
		4	7.6 (25)	91.4 (300)	152.4 (500)	213.4 (700)	18.3 (60)	91.4 (300)	243.8 (800)	243.8 (800)	243.8 (800)	182.9 (600)	243.8 (800)	243.8 (800)	1321-RWR8-DP							●
	5.5	2	7.6 (25)	137.2 (450)	304.8 (1000)	304.8 (1000)	91.4 (300)	304.8 (1000)	304.8 (1000)	304.8 (1000)	304.8 (1000)	304.8 (1000)	304.8 (1000)	304.8 (1000)	1321-RWR12-DP				●			●
		4	7.6 (25)	91.4 (300)	152.4 (500)	213.4 (700)	18.3 (60)	91.4 (300)	304.8 (1000)	304.8 (1000)	304.8 (1000)	182.9 (600)	304.8 (1000)	304.8 (1000)	1321-RWR12-DP							●

PowerFlex 700 Technical Data

Frame	Rating		No Solution				Reactor Only				Reactor + Damping Resistor or 1321-RWR				Reactor/RWR	Resistor		Available Options					
	kW	kHz	1000V	1200V	1488V	1600V	1000V	1200V	1488V	1600V	1000V	1200V	1488V	1600V		Cat. No.	Ohms	Watts	TFA1	TFB2	RWR2	RWC	
1	7.5	2	7.6 (25)	137.2 (450)	365.8 (1200)	365.8 (1200)	91.4 (300)	365.8 (1200)	365.8 (1200)	365.8 (1200)	365.8 (1200)	365.8 (1200)	365.8 (1200)	365.8 (1200)	1321-RWR18-DP				●		●		
		4	7.6 (25)	91.4 (300)	152.4 (500)	213.4 (700)	18.3 (60)	91.4 (300)	365.8 (1200)	365.8 (1200)	182.9 (600)	304.8 (1000)	365.8 (1200)	365.8 (1200)	1321-RWR18-DP							●	
	11	2	7.6 (25)	137.2 (450)	365.8 (1200)	365.8 (1200)	91.4 (300)	365.8 (1200)	365.8 (1200)	365.8 (1200)	365.8 (1200)	365.8 (1200)	365.8 (1200)	365.8 (1200)	1321-RWR25-DP				●				
		4	7.6 (25)	91.4 (300)	152.4 (500)	213.4 (700)	18.3 (60)	91.4 (300)	365.8 (1200)	365.8 (1200)	182.9 (600)	304.8 (1000)	365.8 (1200)	365.8 (1200)	1321-RWR25-DP								
2	15	2	7.6 (25)	137.2 (450)	365.8 (1200)	365.8 (1200)	91.4 (300)	365.8 (1200)	365.8 (1200)	365.8 (1200)	365.8 (1200)	365.8 (1200)	365.8 (1200)	365.8 (1200)	1321-RWR35-DP				●				
		4	7.6 (25)	91.4 (300)	152.4 (500)	213.4 (700)	18.3 (60)	91.4 (300)	365.8 (1200)	365.8 (1200)	182.9 (600)	304.8 (1000)	365.8 (1200)	365.8 (1200)	1321-RWR35-DP								
	18.5	2	7.6 (25)	137.2 (450)	365.8 (1200)	365.8 (1200)	91.4 (300)	365.8 (1200)	365.8 (1200)	365.8 (1200)	365.8 (1200)	365.8 (1200)	365.8 (1200)	365.8 (1200)	1321-RWR35-DP				●				
		4	7.6 (25)	91.4 (300)	152.4 (500)	213.4 (700)	18.3 (60)	91.4 (300)	365.8 (1200)	365.8 (1200)	182.9 (600)	304.8 (1000)	365.8 (1200)	365.8 (1200)	1321-RWR35-DP								
3	22	2	7.6 (25)	137.2 (450)	365.8 (1200)	365.8 (1200)	91.4 (300)	365.8 (1200)	365.8 (1200)	365.8 (1200)	365.8 (1200)	365.8 (1200)	365.8 (1200)	365.8 (1200)	1321-RWR45-DP				●				
		4	7.6 (25)	91.4 (300)	152.4 (500)	213.4 (700)	18.3 (60)	91.4 (300)	365.8 (1200)	365.8 (1200)	182.9 (600)	304.8 (1000)	365.8 (1200)	365.8 (1200)	1321-RWR45-DP								
	30	2	7.6 (25)	137.2 (450)	304.8 (1000)	365.8 (1200)	91.4 (300)	365.8 (1200)	365.8 (1200)	365.8 (1200)	365.8 (1200)	365.8 (1200)	365.8 (1200)	365.8 (1200)	1321-RWR55-DP				●				
		4	7.6 (25)	91.4 (300)	152.4 (500)	213.4 (700)	18.3 (60)	91.4 (300)	365.8 (1200)	365.8 (1200)	182.9 (600)	304.8 (1000)	365.8 (1200)	365.8 (1200)	1321-RWR55-DP								
	37	2	12.2 (40)	137.2 (450)	304.8 (1000)	365.8 (1200)	91.4 (300)	365.8 (1200)	365.8 (1200)	365.8 (1200)	365.8 (1200)	365.8 (1200)	365.8 (1200)	365.8 (1200)	1321-RWR80-DP				●				
		4	12.2 (40)	91.4 (300)	152.4 (500)	213.4 (700)	18.3 (60)	91.4 (300)	365.8 (1200)	365.8 (1200)	182.9 (600)	304.8 (1000)	365.8 (1200)	365.8 (1200)	1321-RWR80-DP								
4	45	2	12.2 (40)	137.2 (450)	304.8 (1000)	365.8 (1200)	91.4 (300)	304.8 (1000)	365.8 (1200)	365.8 (1200)	365.8 (1200)	365.8 (1200)	365.8 (1200)	365.8 (1200)	1321-RWR80-DP				●				
		4	12.2 (40)	91.4 (300)	152.4 (500)	213.4 (700)	24.4 (80)	91.4 (300)	365.8 (1200)	365.8 (1200)	152.4 (500)	304.8 (1000)	365.8 (1200)	365.8 (1200)	1321-RWR80-DP								
5	55	2	12.2 (40)	137.2 (450)	304.8 (1000)	365.8 (1200)	91.4 (300)	274.3 (900)	365.8 (1200)	365.8 (1200)	365.8 (1200)	365.8 (1200)	365.8 (1200)	365.8 (1200)	1321-RWR100-DP				●				
		4	12.2 (40)	91.4 (300)	152.4 (500)	213.4 (700)	24.4 (80)	91.4 (300)	365.8 (1200)	365.8 (1200)	152.4 (500)	304.8 (1000)	365.8 (1200)	365.8 (1200)	1321-RWR100-DP								
	75	2	18.3 (60)	137.2 (450)	304.8 (1000)	365.8 (1200)	91.4 (300)	213.4 (700)	365.8 (1200)	365.8 (1200)	365.8 (1200)	365.8 (1200)	365.8 (1200)	365.8 (1200)	1321-RWR130-DP				●				
		4	18.3 (60)	91.4 (300)	152.4 (500)	213.4 (700)	30.5 (100)	91.4 (300)	304.8 (1000)	365.8 (1200)	152.4 (500)	304.8 (1000)	365.8 (1200)	365.8 (1200)	1321-RWR130-DP								
6	90	2	18.3 (60)	137.2 (450)	304.8 (1000)	365.8 (1200)	91.4 (300)	213.4 (700)	365.8 (1200)	365.8 (1200)	304.8 (1000)	365.8 (1200)	365.8 (1200)	365.8 (1200)	1321-RWR160-DP				●				
		4	18.3 (60)	91.4 (300)	152.4 (500)	213.4 (700)	30.5 (100)	91.4 (300)	365.8 (1200)	365.8 (1200)	121.9 (400)	243.8 (800)	365.8 (1200)	365.8 (1200)	1321-RWR160-DP								
	110	2	24.4 (80)	137.2 (450)	274.3 (900)	365.8 (1200)	76.2 (250)	198.1 (650)	365.8 (1200)	365.8 (1200)	274.3 (900)	365.8 (1200)	365.8 (1200)	365.8 (1200)	1321-RWR200-DP				●				
		4	24.4 (80)	91.4 (300)	152.4 (500)	213.4 (700)	36.6 (120)	91.4 (300)	365.8 (1200)	365.8 (1200)	121.9 (400)	213.4 (700)	365.8 (1200)	365.8 (1200)	1321-RWR200-DP								
	132	2	24.4 (80)	137.2 (450)	274.3 (900)	365.8 (1200)	61.0 (200)	182.9 (600)	365.8 (1200)	365.8 (1200)	243.8 (800)	365.8 (1200)	365.8 (1200)	365.8 (1200)	1321-RWR250-DP				●				
		4	24.4 (80)	91.4 (300)	152.4 (500)	213.4 (700)	36.6 (120)	91.4 (300)	365.8 (1200)	365.8 (1200)	91.4 (300)	182.9 (600)	365.8 (1200)	365.8 (1200)	1321-RWR250-DP								
7	160	2	24.4 (80)	121.9 (400)	243.8 (800)	365.8 (1200)	61.0 (200)	152.4 (500)	304.8 (1000)	365.8 (1200)	243.8 (800)	365.8 (1200)	365.8 (1200)	365.8 (1200)	1321-3RB320-B	50	225		●				
		4	24.4 (80)	91.4 (300)	152.4 (500)	182.9 (600)	36.6 (120)	91.4 (300)	182.9 (600)	274.3 (900)	91.4 (300)	182.9 (600)	365.8 (1200)	365.8 (1200)	1321-3RB320-B	50	450						
	180	2	24.4 (80)	121.9 (400)	243.8 (800)	365.8 (1200)	61.0 (200)	152.4 (500)	304.8 (1000)	365.8 (1200)	243.8 (800)	365.8 (1200)	365.8 (1200)	365.8 (1200)	1321-3RB320-B	50	225		●				
		4	24.4 (80)	91.4 (300)	152.4 (500)	182.9 (600)	36.6 (120)	91.4 (300)	182.9 (600)	274.3 (900)	91.4 (300)	182.9 (600)	365.8 (1200)	365.8 (1200)	1321-3RB320-B	50	450						

PowerFlex 700 Technical Data

Frame	Rating		No Solution				Reactor Only				Reactor + Damping Resistor or 1321-RWR				Reactor/RWR	Resistor		Available Options				
	kW	kHz	1000V	1200V	1488V	1600V	1000V	1200V	1488V	1600V	1000V	1200V	1488V	1600V		Cat. No.	Ohms	Watts	TFA1	TFB2	RWR2	RWC
8	200	2	24.4 (80)	121.9 (400)	243.8 (800)	365.8 (1200)	61.0 (200)	152.4 (500)	304.8 (1000)	365.8 (1200)	243.8 (800)	365.8 (1200)	365.8 (1200)	365.8 (1200)	1321-3RB400-B ⁽¹⁾	20	495		●			
		4	24.4 (80)	91.4 (300)	152.4 (500)	182.9 (600)	36.6 (120)	91.4 (300)	182.9 (600)	228.6 (750)	91.4 (300)	182.9 (600)	304.8 (1000)	365.8 (1200)	1321-3RB400-B ⁽¹⁾	20	990					
	240	2	24.4 (80)	121.9 (400)	243.8 (800)	365.8 (1200)	61.0 (200)	152.4 (500)	304.8 (1000)	365.8 (1200)	243.8 (800)	365.8 (1200)	365.8 (1200)	365.8 (1200)	1321-3R400-B ⁽¹⁾	20	495		●			
		4	24.4 (80)	91.4 (300)	152.4 (500)	182.9 (600)	36.6 (120)	91.4 (300)	167.6 (550)	213.4 (700)	91.4 (300)	182.9 (600)	304.8 (1000)	365.8 (1200)	1321-3RB400-B ⁽¹⁾	20	990					
	280	2	24.4 (80)	121.9 (400)	213.4 (700)	304.8 (1000)	45.7 (150)	121.9 (400)	304.8 (1000)	365.8 (1200)	228.6 (750)	365.8 (1200)	365.8 (1200)	365.8 (1200)	1321-3R500-B ⁽¹⁾	20	495		●			
		4	24.4 (80)	91.4 (300)	152.4 (500)	182.9 (600)	36.6 (120)	91.4 (300)	167.6 (550)	213.4 (700)	91.4 (300)	182.9 (600)	304.8 (1000)	365.8 (1200)	1321-3R500-B ⁽¹⁾	20	990					
	300	2	24.4 (80)	121.9 (400)	213.4 (700)	259.1 (850)	45.7 (150)	121.9 (400)	304.8 (1000)	365.8 (1200)	228.6 (750)	365.8 (1200)	365.8 (1200)	365.8 (1200)	1321-3R600-B ⁽¹⁾	20	495		●			
		4	24.4 (80)	91.4 (300)	152.4 (500)	182.9 (600)	36.6 (120)	91.4 (300)	167.6 (550)	213.4 (700)	91.4 (300)	182.9 (600)	304.8 (1000)	365.8 (1200)	1321-3R600-B ⁽¹⁾	20	990					
8	350	2	24.4 (80)	121.9 (400)	213.4 (500)	259.1 (850)	45.7 (150)	121.9 (400)	304.8 (1000)	365.8 (1200)	228.6 (750)	304.8 (1000)	365.8 (1200)	365.8 (1200)	1321-3R600-B ⁽¹⁾	20	495		●			
		4	24.4 (80)	91.4 (300)	152.4 (500)	182.9 (600)	36.6 (120)	91.4 (300)	167.6 (550)	213.4 (700)	91.4 (300)	182.9 (600)	304.8 (1000)	365.8 (1200)	1321-3R600-B ⁽¹⁾	20	990					
9	400	2	24.4 (80)	91.4 (300)	152.4 (450)	213.4 (550)	36.6 (120)	91.4 (300)	304.8 (1000)	365.8 (1200)	198.1 (650)	274.3 (900)	365.8 (1200)	365.8 (1200)	1321-3R750-B ⁽²⁾	20	735		●			
		4	24.4 (80)	91.4 (300)	137.2 (450)	167.6 (550)	36.6 (120)	91.4 (300)	152.4 (500)	182.9 (600)	76.2 (250)	137.2 (450)	274.3 (900)	365.8 (1200)	1321-3R750-B ⁽²⁾	20	1470					
10	500	2	24.4 (80)	91.4 (300)	152.4 (450)	213.4 (550)	36.6 (120)	91.4 (300)	304.8 (1000)	365.8 (1200)	198.1 (650)	274.3 (900)	365.8 (1200)	365.8 (1200)	1321-3R850-B ⁽²⁾	20	735		●			
		4	24.4 (80)	91.4 (300)	137.2 (450)	167.6 (550)	36.6 (120)	91.4 (300)	152.4 (500)	182.9 (600)	76.2 (250)	137.2 (450)	274.3 (900)	365.8 (1200)	1321-3R850-B ⁽²⁾	20	1470					

(1) Requires two parallel cables.

(2) Requires three parallel cables.

PowerFlex 700 (Standard/Vector), 480V Shielded/Unshielded Cable - Meters (Feet)

Frame	Rating		No Solution				Reactor Only				Reactor + Damping Resistor or 1321-RWR				Reactor/RWR	Resistor		Available Options				
	HP	kHz	1000V	1200V	1488V	1600V	1000V	1200V	1488V	1600V	1000V	1200V	1488V	1600V		Cat. No.	Ohms	Watts	TFA1	TFB2	RWR2	RWC
0	0.5	2	7.6 (25)	12.2 (40)	53.3 (175)	53.3 (175)	7.6 (25)	91.4 (300)	121.9 (400)	121.9 (400)	121.9 (400)	121.9 (400)	121.9 (400)	121.9 (400)				●		●	●	
		4	7.6 (25)	12.2 (40)	53.3 (175)	53.3 (175)	7.6 (25)	12.2 (40)	121.9 (400)	121.9 (400)	121.9 (400)	121.9 (400)	121.9 (400)	121.9 (400)						●	●	
	1	2	7.6 (25)	12.2 (40)	83.8 (275)	83.8 (275)	7.6 (25)	91.4 (300)	152.4 (500)	152.4 (500)	152.4 (500)	152.4 (500)	152.4 (500)	152.4 (500)				●		●	●	
		4	7.6 (25)	12.2 (40)	76.2 (250)	76.2 (250)	7.6 (25)	12.2 (40)	121.9 (400)	152.4 (500)	152.4 (500)	152.4 (500)	152.4 (500)	152.4 (500)						●	●	
	2	2	7.6 (25)	12.2 (40)	83.8 (275)	83.8 (275)	7.6 (25)	91.4 (300)	182.9 (600)	182.9 (600)	182.9 (600)	182.9 (600)	182.9 (600)	182.9 (600)				●	●	●	●	
		4	7.6 (25)	12.2 (40)	76.2 (250)	76.2 (250)	7.6 (25)	12.2 (40)	121.9 (400)	182.9 (600)	182.9 (600)	182.9 (600)	182.9 (600)	182.9 (600)						●	●	
	3	2	7.6 (25)	12.2 (40)	129.5 (425)	129.5 (425)	7.6 (25)	91.4 (300)	182.9 (600)	182.9 (600)	182.9 (600)	182.9 (600)	182.9 (600)	182.9 (600)				●	●	●	●	
		4	7.6 (25)	12.2 (40)	121.9 (400)	121.9 (400)	7.6 (25)	12.2 (40)	121.9 (400)	182.9 (600)	182.9 (600)	182.9 (600)	182.9 (600)	182.9 (600)						●	●	
	5	2	7.6 (25)	12.2 (40)	137.2 (450)	182.9 (600)	7.6 (25)	91.4 (300)	243.8 (800)	243.8 (800)	182.9 (600)	243.8 (800)	243.8 (800)	243.8 (800)	1321-RWR8-DP				●	●	●	●
		4	7.6 (25)	12.2 (40)	121.9 (400)	182.9 (600)	7.6 (25)	12.2 (40)	121.9 (400)	243.8 (800)	182.9 (600)	243.8 (800)	243.8 (800)	243.8 (800)	1321-RWR8-DP						●	●
	7.5	2	7.6 (25)	12.2 (40)	137.2 (450)	182.9 (600)	7.6 (25)	91.4 (300)	304.8 (1000)	304.8 (1000)	182.9 (600)	304.8 (1000)	304.8 (1000)	304.8 (1000)	1321-RWR12-DP				●			●
		4	7.6 (25)	12.2 (40)	121.9 (400)	182.9 (600)	7.6 (25)	12.2 (40)	121.9 (400)	304.8 (1000)	182.9 (600)	304.8 (1000)	304.8 (1000)	304.8 (1000)	1321-RWR12-DP							●

PowerFlex 700 Technical Data

Frame	Rating		No Solution				Reactor Only				Reactor + Damping Resistor or 1321-RWR				Reactor/RWR	Resistor		Available Options				
	HP	kHz	1000V	1200V	1488V	1600V	1000V	1200V	1488V	1600V	1000V	1200V	1488V	1600V		Cat. No.	Ohms	Watts	TFA1	TFB2	RWR2	RWC
1	10	2	7.6 (25)	12.2 (40)	137.2 (450)	182.9 (600)	7.6 (25)	91.4 (300)	365.8 (1200)	365.8 (1200)	182.9 (600)	365.8 (1200)	365.8 (1200)	365.8 (1200)	1321-RWR18-DP				●			●
		4	7.6 (25)	12.2 (40)	121.9 (400)	182.9 (600)	7.6 (25)	12.2 (40)	121.9 (400)	304.8 (1000)	182.9 (600)	304.8 (1000)	365.8 (1200)	365.8 (1200)	1321-RWR18-DP							●
	15	2	7.6 (25)	12.2 (40)	137.2 (450)	182.9 (600)	7.6 (25)	91.4 (300)	365.8 (1200)	365.8 (1200)	182.9 (600)	365.8 (1200)	365.8 (1200)	365.8 (1200)	1321-RWR25-DP				●			
		4	7.6 (25)	12.2 (40)	121.9 (400)	182.9 (600)	7.6 (25)	12.2 (40)	121.9 (400)	304.8 (1000)	182.9 (600)	304.8 (1000)	365.8 (1200)	365.8 (1200)	1321-RWR25-DP							
2	20	2	7.6 (25)	12.2 (40)	137.2 (450)	182.9 (600)	7.6 (25)	91.4 (300)	365.8 (1200)	365.8 (1200)	182.9 (600)	365.8 (1200)	365.8 (1200)	365.8 (1200)	1321-RWR35-DP				●			
		4	7.6 (25)	12.2 (40)	121.9 (400)	182.9 (600)	7.6 (25)	12.2 (40)	121.9 (400)	304.8 (1000)	182.9 (600)	304.8 (1000)	365.8 (1200)	365.8 (1200)	1321-RWR35-DP							
	25	2	7.6 (25)	12.2 (40)	137.2 (450)	182.9 (600)	7.6 (25)	76.2 (250)	365.8 (1200)	365.8 (1200)	182.9 (600)	365.8 (1200)	365.8 (1200)	365.8 (1200)	1321-RWR35-DP				●			
		4	7.6 (25)	12.2 (40)	121.9 (400)	182.9 (600)	7.6 (25)	12.2 (40)	121.9 (400)	274.3 (900)	152.4 (500)	304.8 (1000)	365.8 (1200)	365.8 (1200)	1321-RWR35-DP							
3	30	2	7.6 (25)	12.2 (40)	137.2 (450)	182.9 (600)	7.6 (25)	76.2 (250)	365.8 (1200)	365.8 (1200)	182.9 (600)	365.8 (1200)	365.8 (1200)	365.8 (1200)	1321-RWR45-DP				●			
		4	7.6 (25)	12.2 (40)	121.9 (400)	182.9 (600)	7.6 (25)	12.2 (40)	121.9 (400)	243.8 (800)	152.4 (500)	304.8 (1000)	365.8 (1200)	365.8 (1200)	1321-RWR45-DP							
	40	2	7.6 (25)	12.2 (40)	137.2 (450)	182.9 (600)	7.6 (25)	76.2 (250)	365.8 (1200)	365.8 (1200)	152.4 (500)	365.8 (1200)	365.8 (1200)	365.8 (1200)	1321-RWR55-DP				●			
		4	7.6 (25)	12.2 (40)	106.7 (350)	152.4 (500)	7.6 (25)	12.2 (40)	106.7 (350)	228.6 (750)	121.9 (400)	243.8 (800)	365.8 (1200)	365.8 (1200)	1321-RWR55-DP							
3	50	2	12.2 (40)	18.3 (60)	137.2 (450)	182.9 (600)	12.2 (40)	61.0 (200)	304.8 (1000)	365.8 (1200)	152.4 (500)	365.8 (1200)	365.8 (1200)	365.8 (1200)	1321-RWR80-DP				●			
		4	7.6 (25)	12.2 (40)	91.4 (300)	152.4 (500)	12.2 (40)	18.3 (60)	106.7 (350)	228.6 (750)	91.4 (300)	243.8 (800)	365.8 (1200)	365.8 (1200)	1321-RWR80-DP							
4	60	2	12.2 (40)	18.3 (60)	137.2 (450)	182.9 (600)	12.2 (40)	61.0 (200)	304.8 (1000)	365.8 (1200)	137.2 (450)	365.8 (1200)	365.8 (1200)	365.8 (1200)	1321-RWR80-DP				●			
		4	7.6 (25)	12.2 (40)	91.4 (300)	152.4 (500)	12.2 (40)	24.4 (80)	91.4 (300)	228.6 (750)	76.2 (250)	213.4 (700)	365.8 (1200)	365.8 (1200)	1321-RWR80-DP							
5	75	2	12.2 (40)	18.3 (60)	137.2 (450)	182.9 (600)	12.2 (40)	61.0 (200)	274.3 (900)	365.8 (1200)	137.2 (450)	365.8 (1200)	365.8 (1200)	365.8 (1200)	1321-RWR100-DP				●			
		4	7.6 (25)	12.2 (40)	91.4 (300)	152.4 (500)	12.2 (40)	24.4 (80)	91.4 (300)	182.9 (600)	76.2 (250)	182.9 (600)	365.8 (1200)	365.8 (1200)	1321-RWR100-DP							
	100	2	12.2 (40)	24.4 (80)	137.2 (450)	182.9 (600)	12.2 (40)	61.0 (200)	243.8 (800)	365.8 (1200)	137.2 (450)	365.8 (1200)	365.8 (1200)	365.8 (1200)	1321-RWR130-DP				●			
		4	7.6 (25)	18.3 (60)	91.4 (300)	152.4 (500)	12.2 (40)	30.5 (100)	91.4 (300)	152.4 (500)	61.0 (200)	137.2 (450)	304.8 (1000)	304.8 (1000)	1321-RWR130-DP							
6	125	2	12.2 (40)	24.4 (80)	137.2 (450)	182.9 (600)	12.2 (40)	61.0 (200)	243.8 (800)	365.8 (1200)	121.9 (400)	304.8 (1000)	365.8 (1200)	365.8 (1200)	1321-RWR160-DP				●			
		4	7.6 (25)	18.3 (60)	91.4 (300)	152.4 (500)	12.2 (40)	30.5 (100)	91.4 (300)	152.4 (500)	61.0 (200)	106.7 (350)	243.8 (800)	274.3 (900)	1321-RWR160-DP							
	150	2	12.2 (40)	24.4 (80)	137.2 (450)	182.9 (600)	12.2 (40)	61.0 (200)	243.8 (800)	304.8 (1000)	91.4 (300)	274.3 (900)	365.8 (1200)	365.8 (1200)	1321-RWR200-DP				●			
		4	7.6 (25)	24.4 (80)	91.4 (300)	152.4 (500)	12.2 (40)	30.5 (100)	91.4 (300)	152.4 (500)	45.7 (150)	76.2 (250)	243.8 (800)	274.3 (900)	1321-RWR200-DP							
200	2	12.2 (40)	30.5 (100)	137.2 (450)	182.9 (600)	12.2 (40)	61.0 (200)	243.8 (800)	304.8 (1000)	76.2 (250)	274.3 (900)	365.8 (1200)	365.8 (1200)	1321-RWR250-DP				●				
		7.6 (25)	24.4 (80)	91.4 (300)	121.9 (400)	12.2 (40)	36.6 (120)	91.4 (300)	121.9 (400)	45.7 (150)	76.2 (250)	213.4 (700)	274.3 (900)	1321-RWR250-DP								
7	250	2	12.2 (40)	30.5 (100)	137.2 (450)	167.6 (550)	12.2 (40)	61.0 (200)	198.1 (650)	259.1 (850)	76.2 (250)	243.8 (800)	365.8 (1200)	365.8 (1200)	1321-3RB320-B	50	225		●			
		4	7.6 (25)	24.4 (80)	91.4 (300)	121.9 (400)	12.2 (40)	30.5 (100)	91.4 (300)	121.9 (400)	45.7 (150)	76.2 (250)	213.4 (700)	274.3 (900)	1321-3RB320-B	50	450					
	250	2	12.2 (40)	30.5 (100)	137.2 (450)	167.6 (550)	12.2 (40)	61.0 (200)	198.1 (650)	259.1 (850)	76.2 (250)	243.8 (800)	365.8 (1200)	365.8 (1200)	1321-3RB320-B	50	225		●			
		4	7.6 (25)	24.4 (80)	91.4 (300)	121.9 (400)	12.2 (40)	30.5 (100)	91.4 (300)	121.9 (400)	45.7 (150)	76.2 (250)	213.4 (700)	274.3 (900)	1321-3RB320-B	50	450					

PowerFlex 700 Technical Data

Frame	Rating		No Solution				Reactor Only				Reactor + Damping Resistor or 1321-RWR				Reactor/RWR	Resistor		Available Options				
	HP	kHz	1000V	1200V	1488V	1600V	1000V	1200V	1488V	1600V	1000V	1200V	1488V	1600V	Cat. No.	Ohms	Watts	TFA1	TFB2	RWR2	RWC	
8	300	2	12.2 (40)	30.5 (100)	106.7 (350)	152.4 (500)	12.2 (40)	45.7 (150)	137.2 (450)	198.1 (650)	61.0 (200)	243.8 (800)	365.8 (1200)	365.8 (1200)	1321-3RB400-B ⁽¹⁾	20	495		●			
		4	7.6 (25)	24.4 (80)	91.4 (300)	121.9 (400)	12.2 (40)	30.5 (100)	91.4 (300)	121.9 (400)	45.7 (150)	76.2 (250)	213.4 (700)	274.3 (900)	1321-3RB400-B ⁽¹⁾	20	990					
	350	2	12.2 (40)	30.5 (100)	106.7 (350)	152.4 (500)	12.2 (40)	45.7 (150)	137.2 (450)	198.1 (650)	61.0 (200)	243.8 (800)	365.8 (1200)	365.8 (1200)	1321-3R400-B ⁽¹⁾	20	495		●			
		4	7.6 (25)	24.4 (80)	91.4 (300)	121.9 (400)	12.2 (40)	30.5 (100)	91.4 (300)	121.9 (400)	45.7 (150)	76.2 (250)	167.6 (550)	259.1 (850)	1321-3RB400-B ⁽¹⁾	20	990					
	400	2	12.2 (40)	30.5 (100)	106.7 (350)	152.4 (500)	12.2 (40)	45.7 (150)	137.2 (450)	182.9 (600)	61.0 (200)	213.4 (700)	365.8 (1200)	365.8 (1200)	1321-3R500-B ⁽¹⁾	20	495		●			
		4	7.6 (25)	24.4 (80)	91.4 (300)	121.9 (400)	12.2 (40)	30.5 (100)	91.4 (300)	121.9 (400)	45.7 (150)	76.2 (250)	167.6 (550)	259.1 (850)	1321-3R500-B ⁽¹⁾	20	990					
	450	2	12.2 (40)	30.5 (100)	106.7 (350)	152.4 (500)	12.2 (40)	45.7 (150)	137.2 (450)	182.9 (600)	61.0 (200)	213.4 (700)	365.8 (1200)	365.8 (1200)	1321-3R600-B ⁽¹⁾	20	495		●			
		4	7.6 (25)	24.4 (80)	91.4 (300)	121.9 (400)	12.2 (40)	30.5 (100)	91.4 (300)	121.9 (400)	45.7 (150)	76.2 (250)	167.6 (550)	259.1 (850)	1321-3R600-B ⁽¹⁾	20	990					
500	2	12.2 (40)	30.5 (100)	106.7 (350)	152.4 (500)	12.2 (40)	45.7 (150)	121.9 (400)	152.4 (400)	61.0 (200)	182.9 (600)	304.8 (1000)	365.8 (1200)	1321-3R600-B ⁽¹⁾	20	495		●				
	4	7.6 (25)	24.4 (80)	91.4 (300)	121.9 (400)	12.2 (40)	30.5 (100)	91.4 (300)	121.9 (400)	45.7 (150)	76.2 (250)	167.6 (550)	243.8 (800)	1321-3R600-B ⁽¹⁾	20	990						
9	600	2	12.2 (40)	30.5 (100)	91.4 (300)	121.9 (400)	12.2 (40)	45.7 (150)	106.7 (350)	137.2 (450)	61.0 (200)	152.4 (500)	274.3 (900)	365.8 (1200)	1321-3R750-B ⁽²⁾	20	735		●			
		4	7.6 (25)	24.4 (80)	91.4 (300)	121.9 (400)	12.2 (40)	30.5 (100)	91.4 (300)	121.9 (400)	45.7 (150)	61.0 (200)	152.4 (500)	213.4 (700)	1321-3R750-B ⁽²⁾	20	1470					
10	700	2	12.2 (40)	30.5 (100)	91.4 (300)	121.9 (400)	12.2 (40)	45.7 (150)	106.7 (350)	137.2 (450)	61.0 (200)	152.4 (500)	274.3 (900)	365.8 (1200)	1321-3R850-B ⁽²⁾	20	735		●			
		4	7.6 (25)	24.4 (80)	91.4 (300)	121.9 (400)	12.2 (40)	30.5 (100)	91.4 (300)	121.9 (400)	30.5 (100)	61.0 (200)	152.4 (500)	213.4 (700)	1321-3R850-B ⁽²⁾	20	1470					

(1) Requires two parallel cables.

(2) Requires three parallel cables.

PowerFlex 700 (Standard/Vector), 600V Shielded/Unshielded Cable - Meters (Feet)

Frame	Rating		No Solution		Reactor Only		1321-RWR		RWR	Available Options			
	HP	kHz	1488V	1850V	1488V	1850V	1488V	1850V	Cat. No.	TFA1	TFB2	RWR2	RWC
0	1	2	42.7 (140)	121.9 (400)	121.9 (400)	121.9 (400)	121.9 (400)	121.9 (400)		●		●	●
		4	30.5 (100)	121.9 (400)	30.5 (100)	121.9 (400)	121.9 (400)	121.9 (400)				●	●
	2	2	42.7 (140)	152.4 (500)	152.4 (500)	152.4 (500)	152.4 (500)	152.4 (500)		●		●	●
		4	30.5 (100)	137.2 (450)	30.5 (100)	152.4 (500)	152.4 (500)	152.4 (500)				●	●
	3	2	42.7 (140)	152.4 (500)	152.4 (500)	182.9 (600)	182.9 (600)	182.9 (600)		●		●	●
		4	30.5 (100)	137.2 (450)	30.5 (100)	152.4 (500)	182.9 (600)	182.9 (600)				●	●
	5	2	42.7 (140)	152.4 (500)	152.4 (500)	243.8 (800)	243.8 (800)	243.8 (800)	1321-RWR8-EP	●		●	●
		4	30.5 (100)	137.2 (450)	30.5 (100)	152.4 (500)	243.8 (800)	243.8 (800)	1321-RWR8-EP			●	●
	7.5	2	42.7 (140)	152.4 (500)	152.4 (500)	304.8 (1000)	304.8 (1000)	304.8 (1000)	1321-RWR12-EP				●
		4	30.5 (100)	137.2 (450)	30.5 (100)	152.4 (500)	304.8 (1000)	304.8 (1000)	1321-RWR12-EP				●
1	10	2	42.7 (140)	182.9 (600)	152.4 (500)	365.8 (1200)	365.8 (1200)	365.8 (1200)	1321-RWR12-EP				●
		4	30.5 (100)	137.2 (450)	30.5 (100)	152.4 (500)	365.8 (1200)	365.8 (1200)	1321-RWR12-EP				●
	15	2	42.7 (140)	182.9 (600)	152.4 (500)	365.8 (1200)	365.8 (1200)	365.8 (1200)	1321-RWR18-EP				
		4	30.5 (100)	137.2 (450)	30.5 (100)	152.4 (500)	304.8 (1000)	365.8 (1200)	1321-RWR18-EP				
2	20	2	42.7 (140)	182.9 (600)	152.4 (500)	365.8 (1200)	365.8 (1200)	365.8 (1200)	1321-RWR25-EP		●		
		4	30.5 (100)	137.2 (450)	30.5 (100)	152.4 (500)	304.8 (1000)	365.8 (1200)	1321-RWR25-EP				
	25	2	42.7 (140)	182.9 (600)	152.4 (500)	365.8 (1200)	365.8 (1200)	365.8 (1200)	1321-RWR35-EP		●		
		4	30.5 (100)	137.2 (450)	30.5 (100)	152.4 (500)	304.8 (1000)	365.8 (1200)	1321-RWR35-EP				
3	30	2	42.7 (140)	182.9 (600)	152.4 (500)	365.8 (1200)	365.8 (1200)	365.8 (1200)	1321-RWR35-EP		●		
		4	30.5 (100)	137.2 (450)	36.6 (120)	152.4 (500)	304.8 (1000)	365.8 (1200)	1321-RWR35-EP				
	40	2	42.7 (140)	182.9 (600)	152.4 (500)	365.8 (1200)	365.8 (1200)	365.8 (1200)	1321-RWR45-EP		●		
		4	30.5 (100)	137.2 (450)	36.6 (120)	152.4 (500)	304.8 (1000)	365.8 (1200)	1321-RWR45-EP				
	50	2	42.7 (140)	182.9 (600)	152.4 (500)	365.8 (1200)	365.8 (1200)	365.8 (1200)	1321-RWR55-EP		●		
		4	36.6 (120)	137.2 (450)	45.7 (150)	152.4 (500)	304.8 (1000)	365.8 (1200)	1321-RWR55-EP				

PowerFlex 700 Technical Data

Frame	Rating		No Solution		Reactor Only		1321-RWR		RWR	Available Options			
	HP	kHz	1488V	1850V	1488V	1850V	1488V	1850V	Cat. No.	TFA1	TFB2	RWR2	RWC
4	60	2	42.7 (140)	182.9 (600)	152.4 (500)	365.8 (1200)	365.8 (1200)	365.8 (1200)	1321-RWR80-EP		●		
		4	36.6 (120)	137.2 (450)	45.7 (150)	152.4 (500)	274.3 (900)	365.8 (1200)	1321-RWR80-EP				
5	75	2	42.7 (140)	182.9 (600)	152.4 (500)	365.8 (1200)	365.8 (1200)	365.8 (1200)	1321-RWR80-EP		●		
		4	36.6 (120)	137.2 (450)	45.7 (150)	152.4 (500)	274.3 (900)	365.8 (1200)	1321-RWR80-EP				
	100	2	42.7 (140)	182.9 (600)	152.4 (500)	304.8 (1000)	365.8 (1200)	365.8 (1200)	1321-RWR100-EP		●		
		4	42.7 (140)	137.2 (450)	45.7 (150)	152.4 (500)	274.3 (900)	365.8 (1200)	1321-RWR100-EP				
6	125	2	42.7 (140)	182.9 (600)	121.9 (400)	304.8 (1000)	365.8 (1200)	365.8 (1200)	1321-RWR130-EP		●		
		4	42.7 (140)	137.2 (450)	45.7 (150)	152.4 (500)	228.6 (750)	365.8 (1200)	1321-RWR130-EP				
	150	2	42.7 (140)	182.9 (600)	121.9 (400)	304.8 (1000)	365.8 (1200)	365.8 (1200)	1321-RWR160-EP		●		
		4	42.7 (140)	137.2 (450)	45.7 (150)	152.4 (500)	198.1 (650)	365.8 (1200)	1321-RWR160-EP				

PowerFlex 700 (Standard/Vector), 690V Shielded/Unshielded Cable - Meters (Feet)

Frame	Rating		No Solution		Reactor Only		Reactor + Damping Resistor		Reactor	Resistor		Available Options			
	kW	kHz	1850V	2000V	1850V	2000V	1850V	2000V	Cat. No.	Ohms	Watts	TFA1	TFB2	RWR2	RWC
4	45	2	30.5 (100)	106.9 (350)	91.4 (300)	152.4 (500)	365.8 (1200)	365.8 (1200)	1321-3R80-C	50	345				
		4	24.4 (80)	76.2 (250)	36.6 (120)	121.9 (400)	213.4 (700)	274.3 (900)	1321-3R80-C	50	690				
	55	2	30.5 (100)	106.9 (350)	91.4 (300)	152.4 (500)	365.8 (1200)	365.8 (1200)	1321-3R80-C	50	345				
		4	24.4 (80)	76.2 (250)	36.6 (120)	106.9 (350)	213.4 (700)	274.3 (900)	1321-3R80-C	50	690				
5	75	2	30.5 (100)	106.9 (350)	91.4 (300)	152.4 (500)	365.8 (1200)	365.8 (1200)	1321-3R100-C	50	345				
		4	30.5 (100)	76.2 (250)	36.6 (120)	106.9 (350)	213.4 (700)	274.3 (900)	1321-3R100-C	50	690				
	90	2	30.5 (100)	106.9 (350)	91.4 (300)	152.4 (500)	365.8 (1200)	365.8 (1200)	1321-3R130-C	50	375				
		4	30.5 (100)	76.2 (250)	36.6 (120)	106.9 (350)	182.9 (600)	274.3 (900)	1321-3R130-C	50	750				
6	110	2	30.5 (100)	106.9 (350)	91.4 (300)	152.4 (500)	365.8 (1200)	365.8 (1200)	1321-3R160-C	50	375				
		4	30.5 (100)	76.2 (250)	36.6 (120)	99.1 (325)	152.4 (500)	274.3 (900)	1321-3R160-C	50	750				
	132	2	30.5 (100)	106.9 (350)	91.4 (300)	152.4 (500)	365.8 (1200)	365.8 (1200)	1321-3R200-C	50	375				
		4	30.5 (100)	76.2 (250)	36.6 (120)	83.8 (275)	152.4 (500)	274.3 (900)	1321-3R200-C	50	750				

Mounting

Operating Temperatures

PowerFlex 700 drives are designed to operate at 0° to 40° C ambient. To operate the drive in installations between 41° and 50° C, see the information below and refer to pages 30-36 for exceptions.

Acceptable Surrounding Air Temperature & Required Actions

Enclosure Rating	Temperature Range	Drive
IP20, NEMA/UL Type 1 (with Top Label) ⁽¹⁾	0-40° C	Frames 0-4, All Ratings
	0-50° C	Frames 5-6, Most Ratings ⁽²⁾
IP20, NEMA/UL Type Open (Top Label Removed) ⁽¹⁾	0-50° C	Most Ratings ⁽²⁾
	0-45° C	20BC072 Only
IP00, NEMA/UL Type Open (Top Label & Vent Plate Removed)	0-50° C	20BC072 Only ⁽³⁾
Flange Mount Front - IP00, NEMA/UL Type Open Back/Heat Sink - IP54, NEMA/UL Type 12	0-40° C Back (External)	Frames 5-6
	0-55° C Front (Inside Enclosure)	
Stand-alone/Wall Mount - IP54, NEMA/UL Type 12	0-40° C	Frames 5-6

(1) Removing the adhesive top label from the drive changes the NEMA/UL enclosure rating from Type 1 to Open. Frames 5 and 6 do not have a top label.

(2) Refer to pages 30-34 for exceptions.

(3) To remove vent plate (see page 48 for location), lift top edge of plate from the chassis. Rotate the plate out from the back plate.

Minimum Mounting Clearances

Frames 0-6

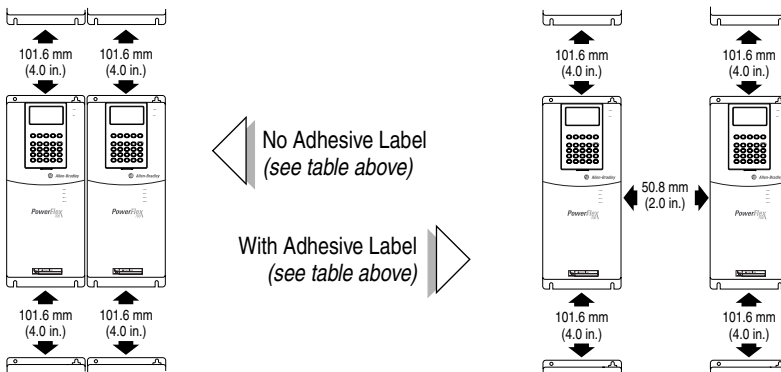

Specified vertical clearance requirements are intended to be from drive to drive. Other objects can occupy this space; however, reduced airflow may cause protection circuits to fault the drive. In addition, inlet air temperature must not exceed the product specification.

Frames 7-10

The drive must be mounted vertically with sufficient space at the top, sides, and front of the cabinet to allow for proper heat dissipation.

Frame	Recommendations
7	Allow a minimum of 152 mm (6.0 in.) at the top and bottom of the enclosure and 102 mm (4.0 in.) on the sides. Flange Mount - Allow a minimum of 152 mm (6.0 in.) at the back of the enclosure (from flange mount surface to wall).
8-10	Allow a minimum of 152 mm (6.0 in.) at the top of the enclosure. Additionally, allow a minimum of 102 mm (4.0 in.) on each side OR 152 mm (6.0 in.) in the back.

PowerFlex 700 Frames

Frame	AC Input									
	208/240		400V		480V		600V		690V	
	ND HP	HD HP	ND kW	HD kW	ND HP	HD HP	ND HP	HD HP	ND kW	HD kW
0	0.5	0.33	0.37	0.25	0.5	0.33	1	0.5	-	-
	1	0.75	0.75	0.55	1	0.75	2	1	-	-
	-	-	1.5	0.75	2	1.5	3	2	-	-
	-	-	2.2	1.5	3	2	5	3	-	-
	-	-	4	2.2	5	3	7.5	5	-	-
1	-	-	5.5	4	7.5	5	-	-	-	-
	2	1.5	7.5	5.5	10	7.5	10	7.5	-	-
	3	2	11	7.5	15	10	15	10	-	-
	5	3	-	-	-	-	-	-	-	-
	7.5	5	-	-	-	-	-	-	-	-
2	10	7.5	15	11	20	15	20	15	-	-
	-	-	18.5	15	25	20	25	20	-	-
3	15	10	22	18.5	30	25	30	25	-	-
	20	15	30	22	40	30	40	30	-	-
	-	-	37	30	50	40	50	40	-	-
4	25	20	45	37	60	50	60	50	-	-
	30	25	-	-	-	-	-	-	-	-
5	40	30	55	45	75	60	75	60	45	37.5
	50	40	75	55	100	75	100	75	55	45
	-	-	-	-	-	-	-	-	75	55
	-	-	-	-	-	-	-	-	90	75
6	60	50	90	75	125	100	125	100	110	90
	75	60	110	90	150	125	150	125	132	110
	100	75	132	110	200	150	-	-	-	-
7	-	-	160	150	250	200	-	-	-	-
	-	-	180	180	250	250	-	-	-	-
8	-	-	200	180	300	250	-	-	-	-
	-	-	240	200	350	300	-	-	-	-
	-	-	280	240	400	350	-	-	-	-
	-	-	300	280	450	400	-	-	-	-
	-	-	350	300	500	450	-	-	-	-
	-	-	400	350	600	500	-	-	-	-
9	-	-	500	400	700	600	-	-	-	-
10	-	-	500	400	700	600	-	-	-	-

Frame	DC Input									
	325V		540V		650V		810V		932V	
	ND HP	HD HP	ND kW	HD kW	ND HP	HD HP	ND HP	HD HP	ND kW	HD kW
0	0.5	0.33	-	-	0.5	0.33	1	0.75	-	-
	1	0.75	-	-	1	0.75	2	1.5	-	-
	-	-	-	-	2	1.5	3	2	-	-
	-	-	-	-	3	2	5	3	-	-
	-	-	-	-	5	3	7.5	5	-	-
1	-	-	-	-	7.5	5	10	7.5	-	-
	2	1.5	0.37	0.25	10	7.5	15	10	-	-
	3	2	0.75	0.55	15	10	-	-	-	-
	5	3	1.5	0.75	-	-	-	-	-	-
	7.5	5	2.2	1.5	-	-	-	-	-	-
	-	-	4	2.2	-	-	-	-	-	-
2	-	-	5.5	4	-	-	-	-	-	-
	-	-	7.5	5.5	-	-	-	-	-	-
	-	-	11	7.5	-	-	-	-	-	-
	10	7.5	15	11	20	15	20	15	-	-
3	-	-	18.5	15	25	20	25	20	-	-
	15	10	22	18.5	30	25	30	25	-	-
4	20	15	30	22	40	30	40	30	-	-
	-	-	37	30	50	40	50	40	-	-
5	25	20	45	37	60	50	60	50	-	-
	30	25	-	-	-	-	-	-	-	-
6	40	30	55	45	75	60	100	75	45	37.5
	50	40	-	-	100	75	-	-	90	75
7	60	50	75	55	125	100	150	125	132	110
	75	60	90	75	150	125	-	-	-	-
	100	75	110	90	-	-	-	-	-	-
	-	-	132	110	200	150	-	-	-	-
8	-	-	160	150	250	200	-	-	-	-
	-	-	180	180	250	250	-	-	-	-
9	-	-	200	180	300	250	-	-	-	-
	-	-	240	200	350	300	-	-	-	-
	-	-	280	240	400	350	-	-	-	-
	-	-	300	280	450	400	-	-	-	-
	-	-	350	300	500	450	-	-	-	-
	-	-	400	350	600	500	-	-	-	-
10	-	-	500	400	700	600	-	-	-	-

Approximate Dimensions

Frames 0-3 (0 Frame Shown)

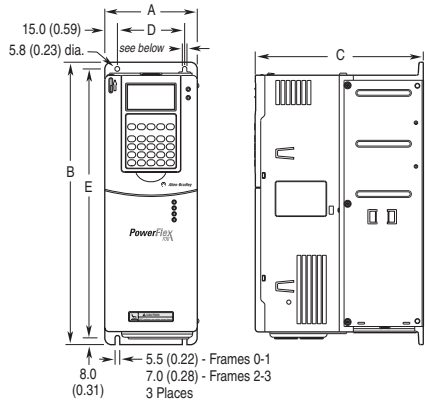

Dimensions are in millimeters and (inches).

Frame ⁽¹⁾	A	B	C	D	E	Weight ⁽²⁾ kg (lbs.)	
						Drive	Drive & Packaging
0	110.0 (4.33)	336.0 (13.23)	200.0 (7.87)	80.0 (3.15)	320.0 (12.60)	5.22 (11.5)	8.16 (18)
1	135.0 (5.31)	336.0 (13.23)	200.0 (7.87)	105.0 (4.13)	320.0 (12.60)	7.03 (15.5)	9.98 (22)
2	222.0 (8.74)	342.5 (13.48)	200.0 (7.87)	192.0 (7.56)	320.0 (12.60)	12.52 (27.6)	15.20 (33.5)
3	222.0 (8.74)	517.5 (20.37)	200.0 (7.87)	192.0 (7.56)	500.0 (19.69)	18.55 (40.9)	22.68 (50)

- (1) Refer to [page 44](#) for frame information.
- (2) Weights include HIM and Standard I/O.

Frame 4

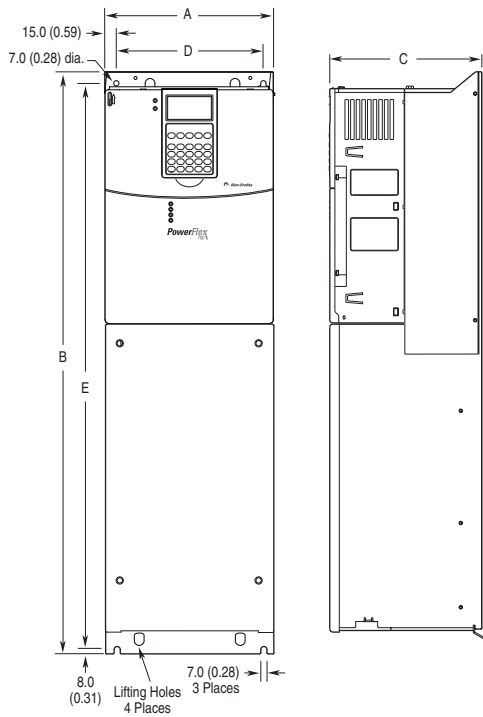

Dimensions are in millimeters and (inches)

Frame ⁽¹⁾	A (Max.)	B	C (Max.)	D	E	Approx. Weight ⁽²⁾ kg (lbs.)	
						Drive	Drive & Packaging
4	220.0 (8.66)	758.8 (29.87)	201.7 (7.94)	192.0 (7.56)	738.2 (29.06)	24.49 (54.0)	29.03 (64.0)

- (1) Refer to [page 44](#) for frame information.
- (2) Weights include HIM and Standard I/O.

Frame 5

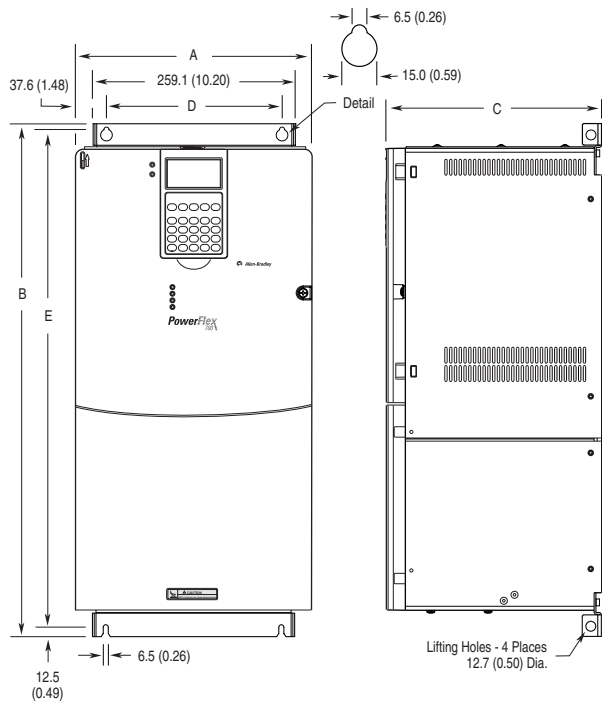

Dimensions are in millimeters and (inches)

Frame ⁽¹⁾	A (Max.)	B	C (Max.)	D	E	Approx. Weight ⁽²⁾ kg (lbs.)	
						Drive	Drive & Packaging
5	308.9 (12.16)	644.5 (25.37) ⁽³⁾	275.4 (10.84)	225.0 (8.86)	625.0 (24.61)	37.19 (82.0)	49.50 (109.0)

- (1) Refer to [page 44](#) for frame information.
- (2) Weights include HIM and Standard I/O. Add 2.70 kg (6.0 lbs.) for the 20BC140 drive.
- (3) When using the supplied junction box (100 HP drives Only), add an additional 45.1 mm (1.78 in.) to this dimension.

Frame 6

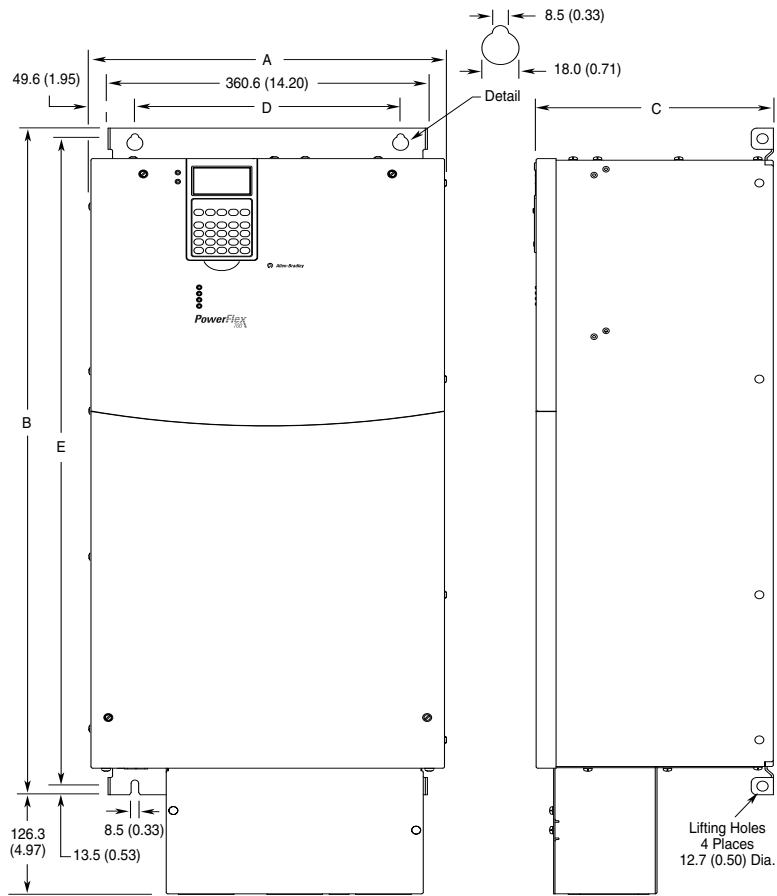

Dimensions are in millimeters and (inches)

Frame (1)	A (Max.)	B (2)	C (Max.)	D	E	Approx. Weight (3) kg (lbs.)	
						Drive	Drive & Packaging
6	403.9 (15.90)	850.0 (33.46)	275.5 (10.85)	300.0 (11.81)	825.0 (32.48)	71.44 (157.5)	100.9 (222.0)

(1) Refer to page 44 for frame information.

(2) Junction Box can be removed if drive is mounted in a cabinet.

(3) Weights include HIM and Standard I/O. Add 13.60 kg (30.0 lbs.) for the following drives; 20BB260, 20BC260 and 20BD248.

Bottom View Dimensions

Frame	Rating	Dimensions
0	All	
1	All	
2	All	

Frame	Rating	Dimensions
3	All except 50 HP, 480V (37 kW, 400V)	
	50 HP, 480V (37 kW, 400V) Normal Duty Drive	
4	All	

Dimensions are in millimeters and (inches)

Frame	Rating	Dimensions
5	75 HP, 480V (55kW, 400V) Normal Duty Drive	<p>Technical drawing of Frame 5 drive. Dimensions include: 104.0 (4.09), 93.2 (3.67), 241.9 (9.52), 229.5 (9.04), 220.0 (8.66), 184.0 (7.24), 159.5 (6.28), 96.0 (3.78), 28.0 (1.10), 45.0 (1.77), 85.0 (3.35), 150.0 (5.91), 215.0 (8.46), 255.0 (10.04), 34.9 (1.37) Dia. (2 Places), 22.2 (0.87) Dia. (2 Places), 62.7 (2.47) Dia. (2 Places).</p>
	100 HP, 480V Normal Duty Drive	<p>Technical drawing of 100 HP drive. Dimensions include: 241.9 (9.52), 223.5 (8.80), 188.5 (7.42), 184.3 (7.26), 153.5 (6.04), 96.0 (3.78), 28.0 (1.10), 44.0 (1.73), 66.4 (2.61), 128.0 (5.04), 232.3 (9.15), 34.9 (1.37) Dia., 22.2 (0.87) Dia. (2 Places), 62.7 (2.47) Dia. (2 Places), Removable Junction Box, 42.6 (1.68), 31.9 (1.26).</p>
6	All	<p>Technical drawing of Frame 6 drive. Dimensions include: 56.2 (2.21), 45.6 (1.80), 242.0 (9.53), 222.3 (8.75), 149.5 (5.85), 116.6 (4.59), 47.1 (1.85), 52.1 (2.05), 69.1 (2.72), 130.1 (5.12), 230.1 (9.06), 280.1 (11.03), 330.1 (13.00), 219.0 (8.62), 185.4 (7.30), 151.8 (5.96), 34.9 (1.37) Dia. (3 Places), 62.7 (2.47) Dia. (3 Places), 22.2 (0.87) Dia. (4 Places), Removable Junction Box.</p>

Dimensions are in millimeters and (inches)

Frame 5 NEMA/UL Type 12 Stand-alone – Series B, 400-690V Only

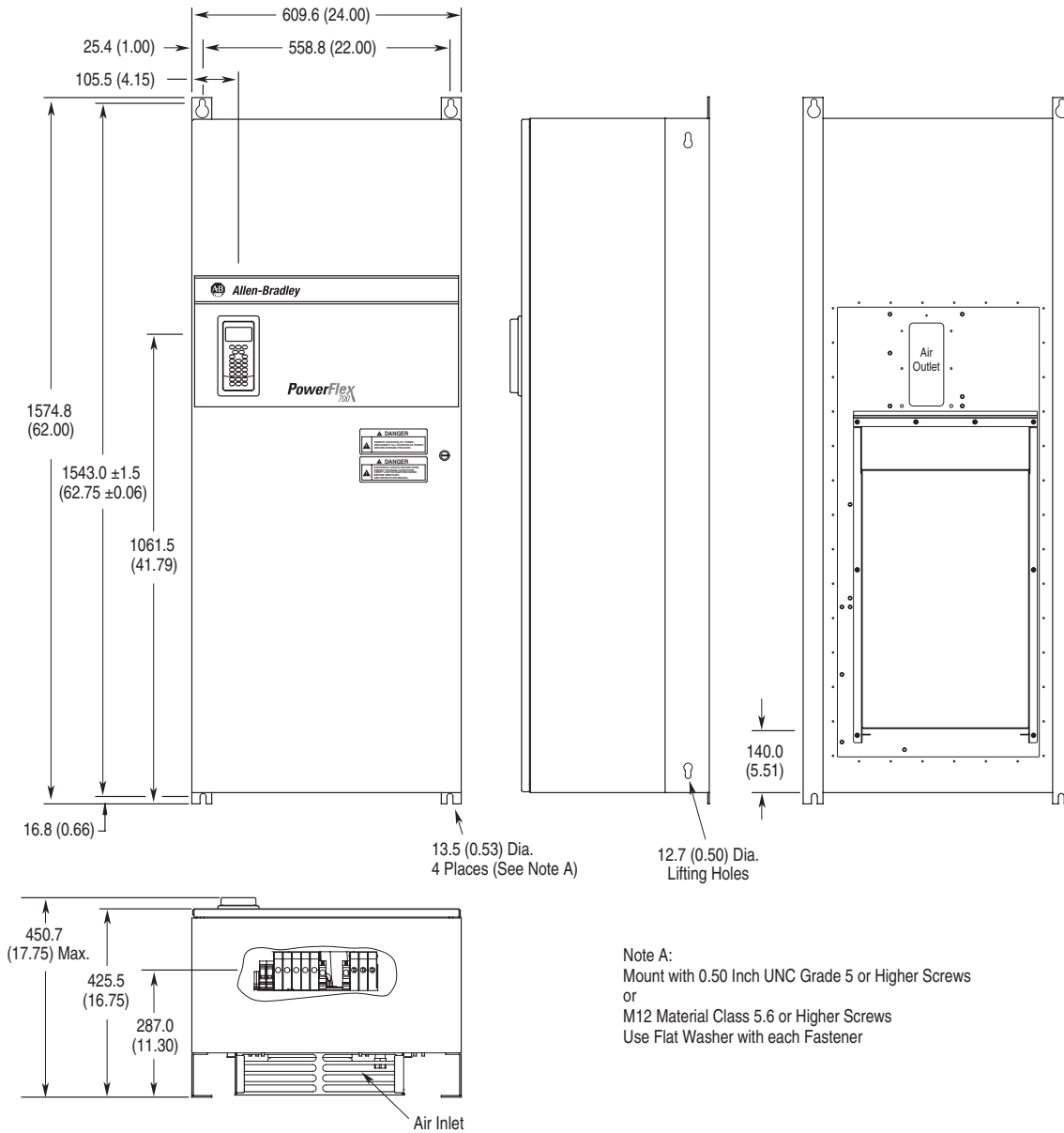

Dimensions are in millimeters and (inches)

Frame	Description	Approx. Weight ⁽¹⁾ kg (lbs.)	
		Drive	Drive & Packaging
5	Stand-alone	102.51 (226.0)	154.68 (341.0)

⁽¹⁾ Weights include HIM and Standard I/O.

Frame 5 NEMA/UL Type 12 Flange Mount – Series B, 400-690V Only

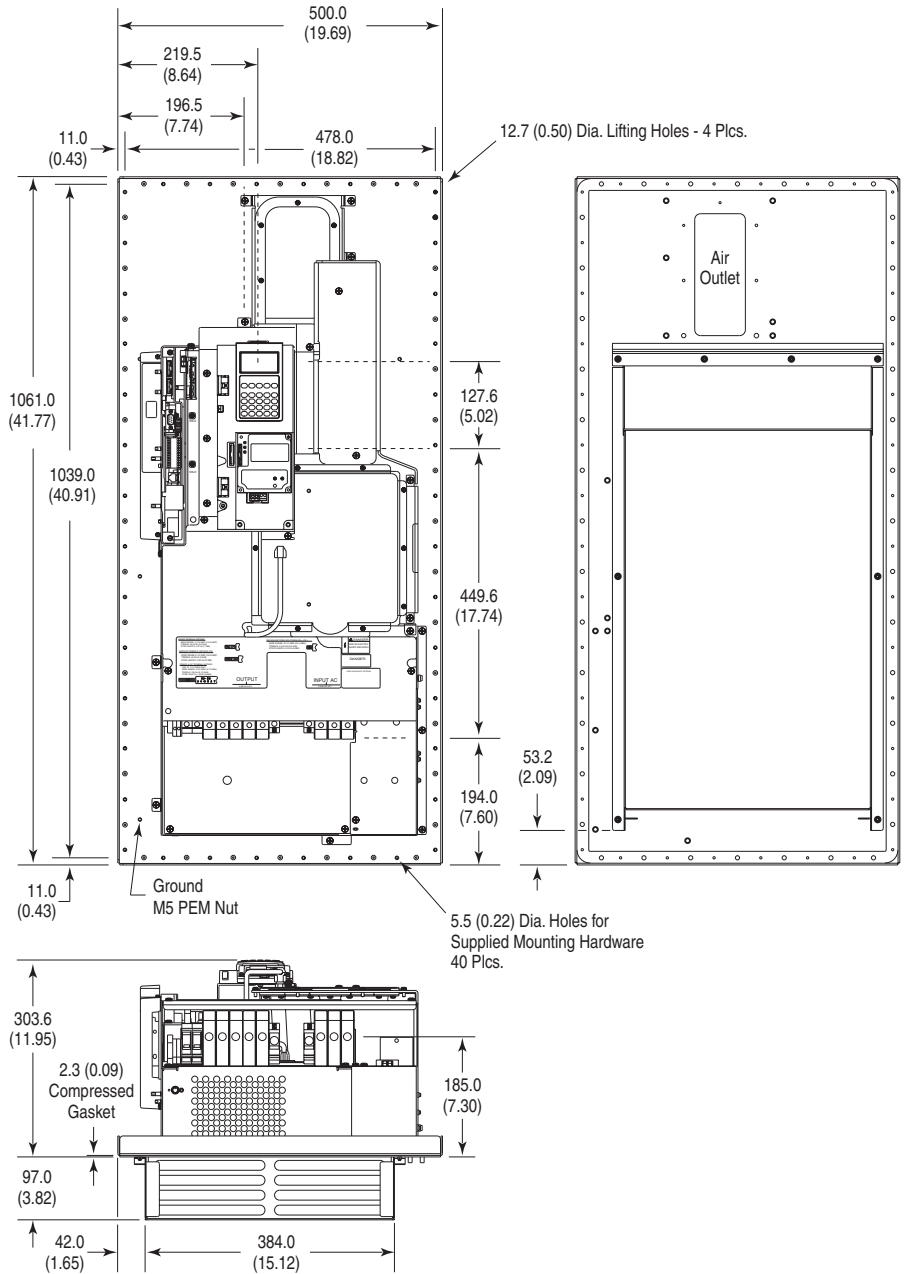

Dimensions are in millimeters and (inches)

Frame	Description	Approx. Weight ⁽¹⁾ kg (lbs.)	
		Drive	Drive & Packaging
5	Flange Mount	61.69 (136.0)	81.65 (180.0)

(1) Weights include HIM and Standard I/O.

Frame 5 Flange Mount Cutout

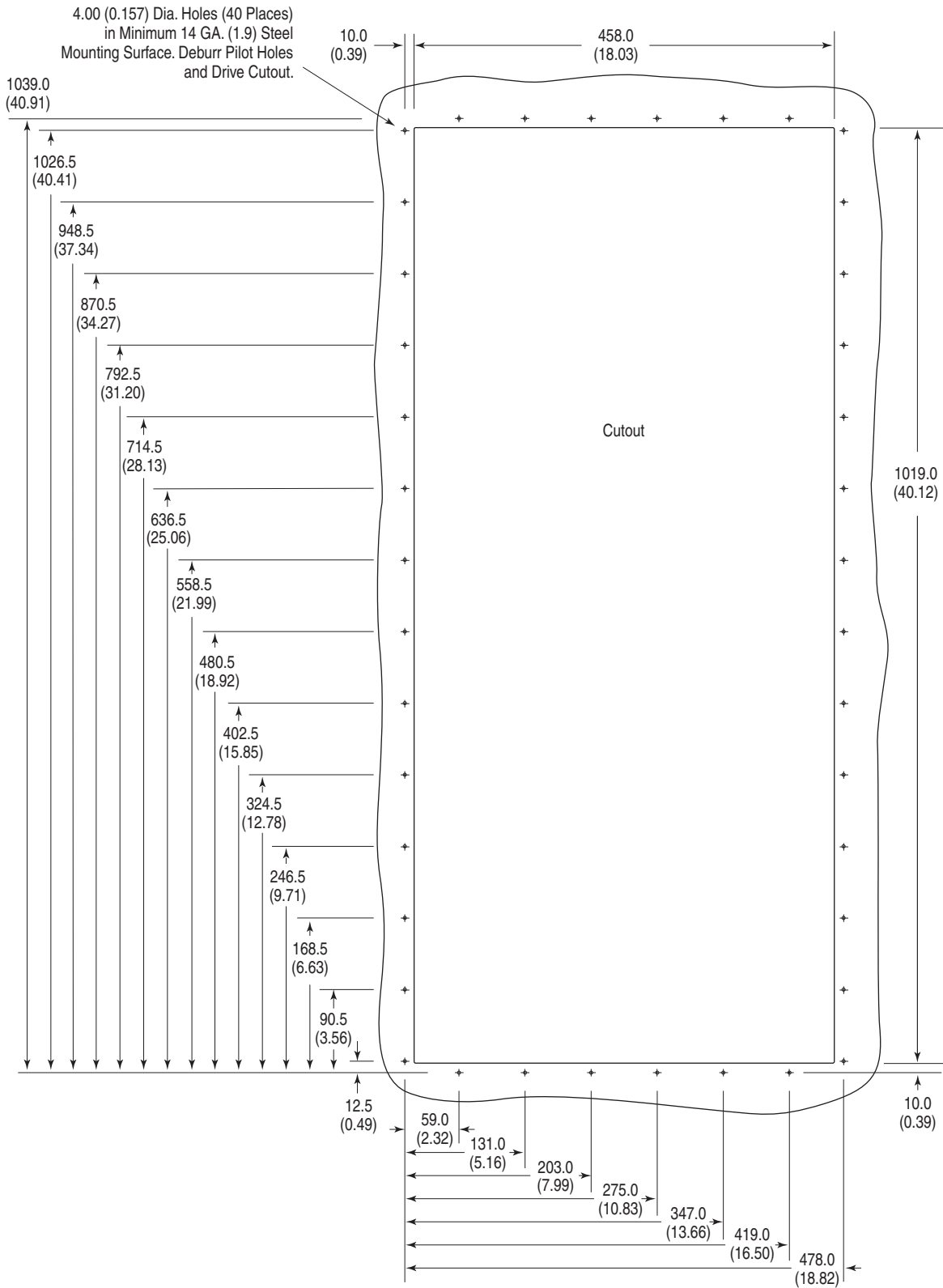

Dimensions are in millimeters and (inches)

Frame 6 NEMA/UL Type 12 Stand-alone – Series B, 400-690V Only

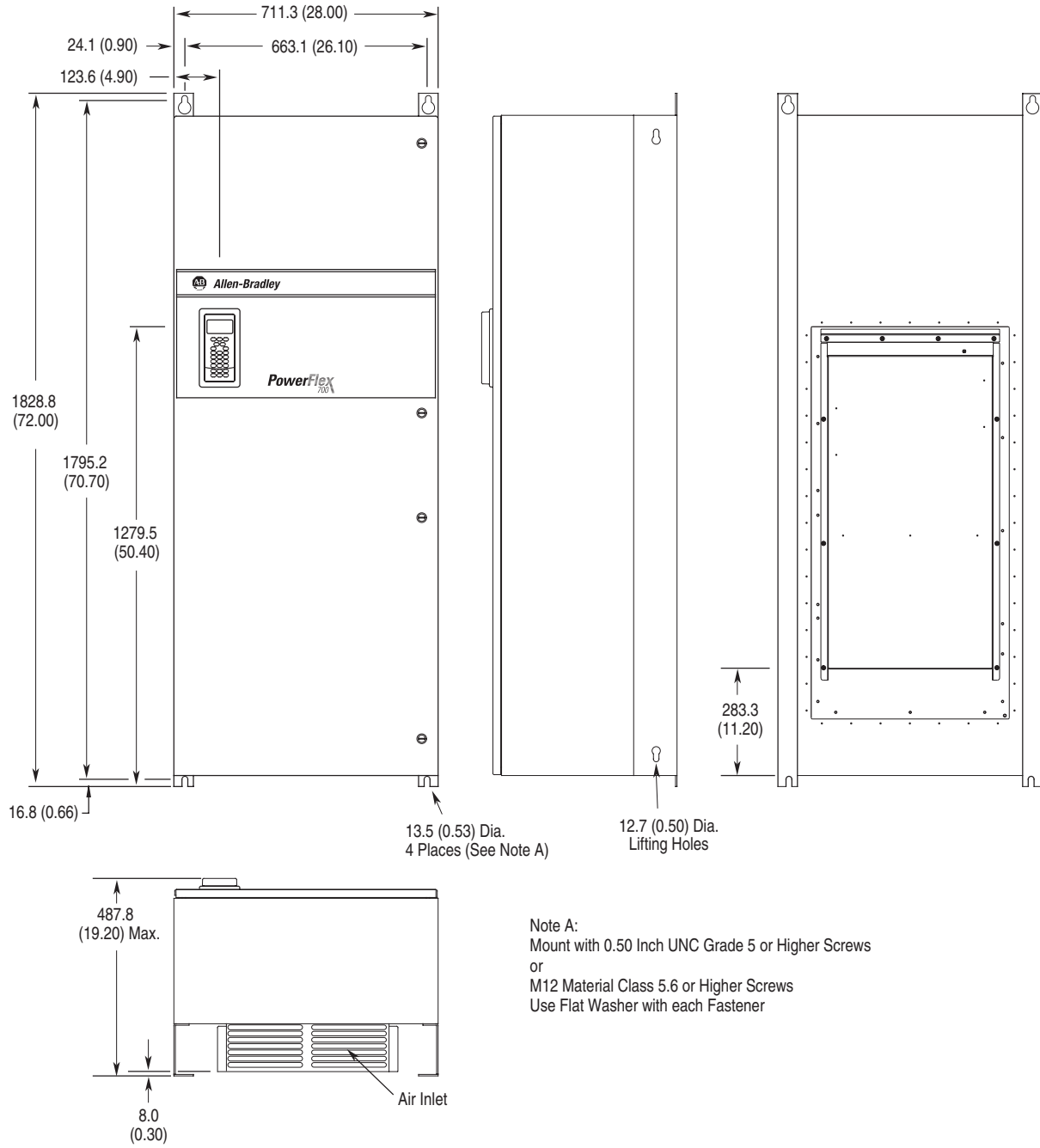

Dimensions are in millimeters and (inches)

Frame	Description	Approx. Weight ⁽¹⁾ kg (lbs.)	
		Drive	Drive & Packaging
6	Stand-alone	176.90 (390.0)	229.07 (505.0)

(1) Weights include HIM and Standard I/O.

Frame 6 NEMA/UL Type 12 Flange Mount – Series B, 400-690V Only

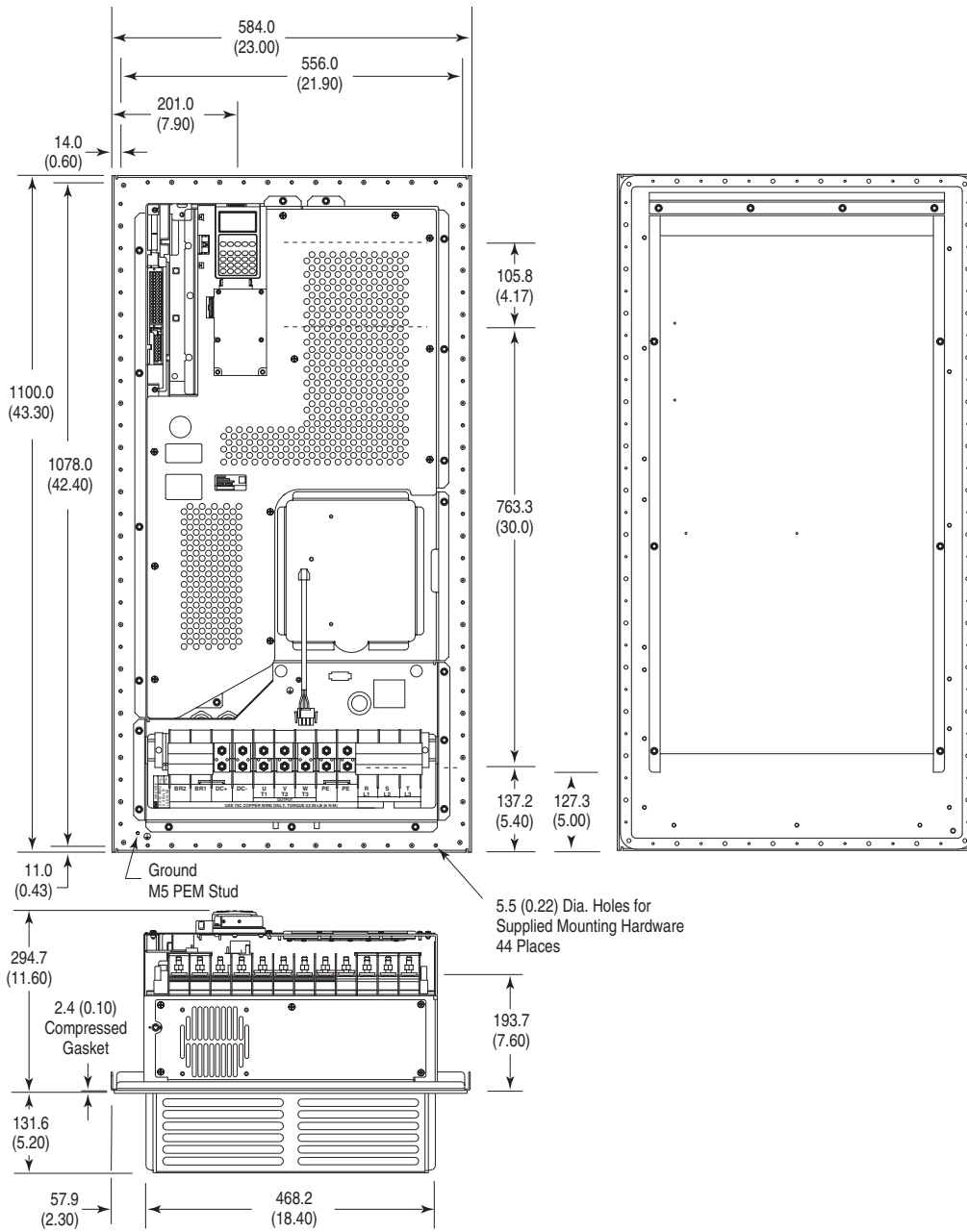

Dimensions are in millimeters and (inches)

Frame	Description	Approx. Weight ⁽¹⁾ kg (lbs.)	
		Drive	Drive & Packaging
6	Flange Mount	99.79 (220.0)	119.75 (264.0)

⁽¹⁾ Weights include HIM and Standard I/O.

Frame 6 Flange Mount Cutout

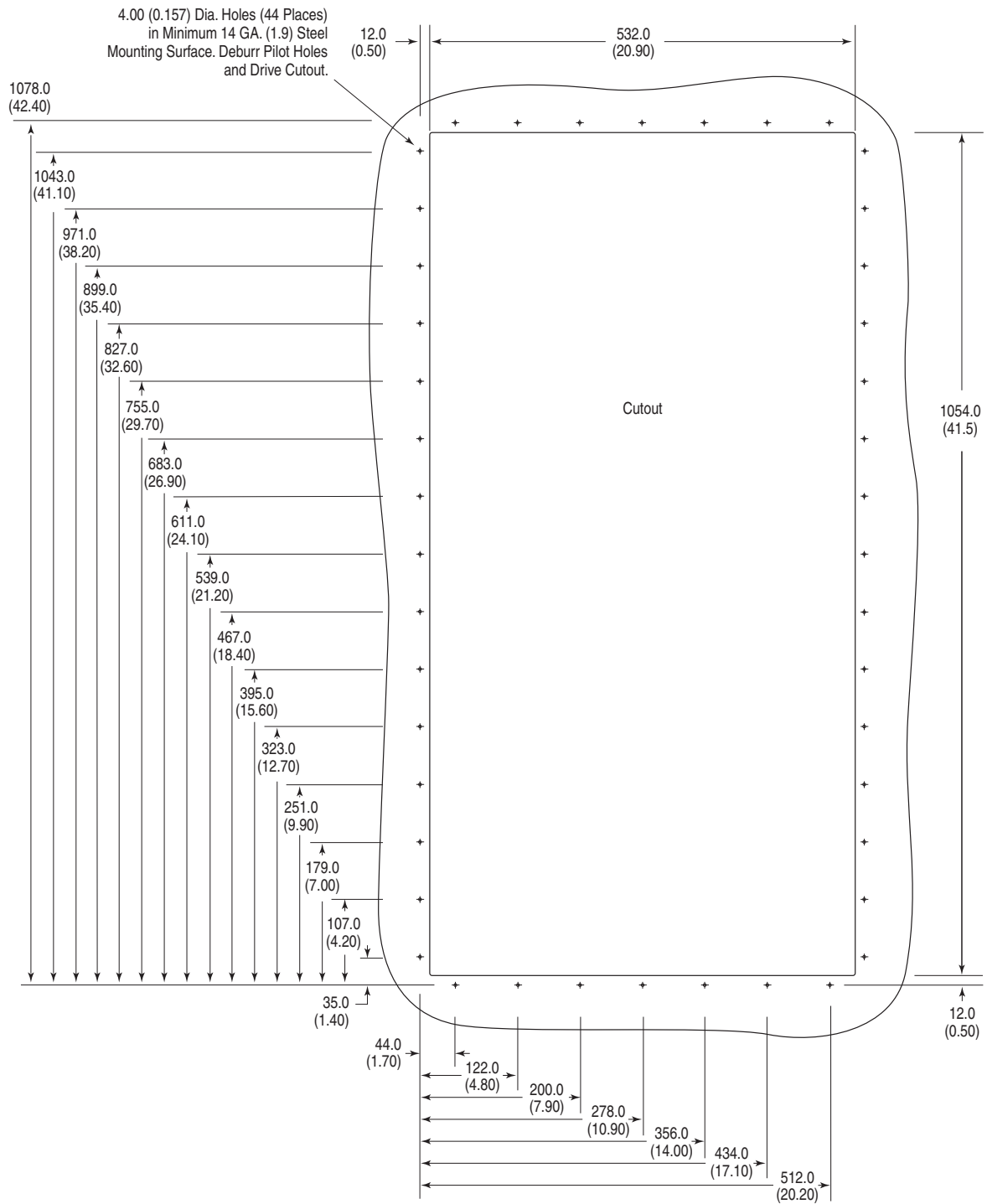

Dimensions are in millimeters and (inches)

Frame 7 IP20, NEMA/UL Type 1 Dimensions

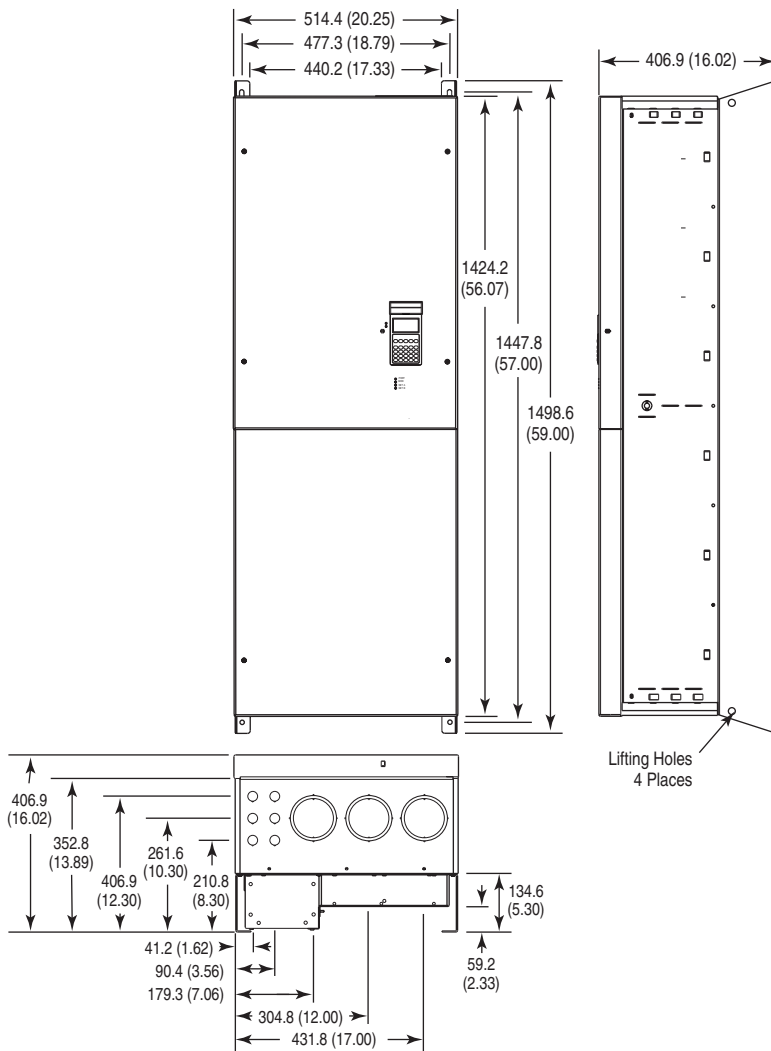

Dimensions are in millimeters and (inches)

Approx. Weight <i>kg (lbs.)</i>	
Drive	Drive & Packaging
170 (375)	196 (433)

Frame 10 IP20, NEMA/UL Type 1 Dimensions

AC Input Shown, for DC Input Dimensions use the Inverter (Left) Bay

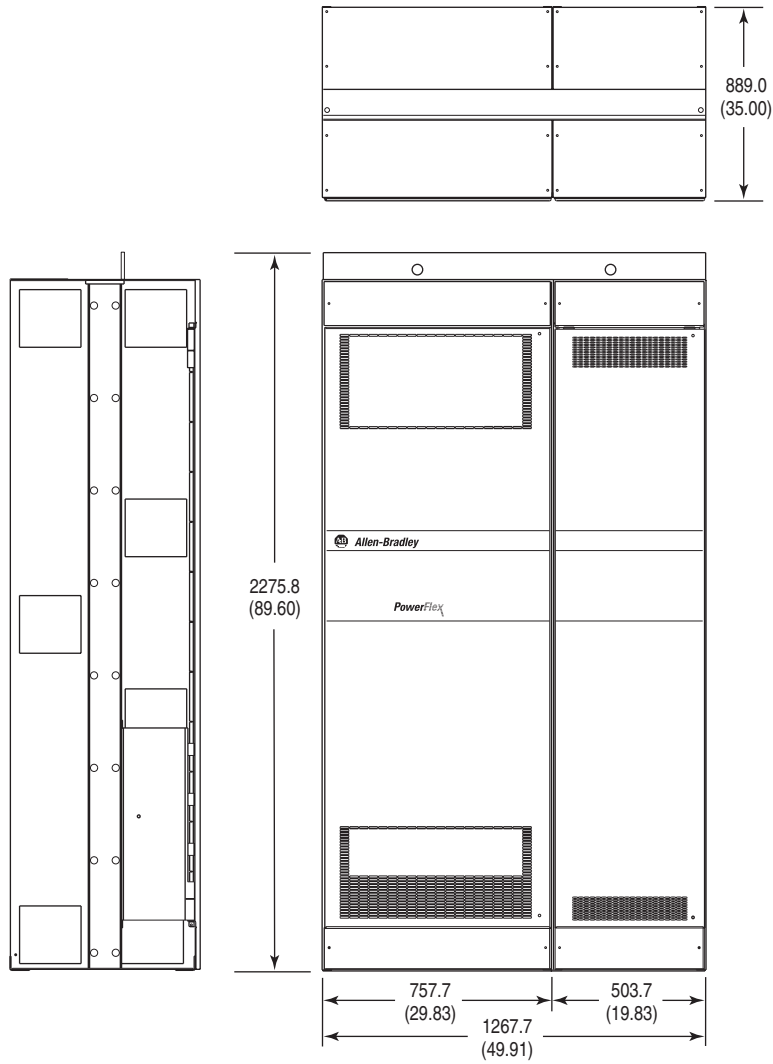

Dimensions are in millimeters and (inches)

Approx. Weight <i>kg (lbs.)</i>		
Type	Drive	Drive & Packaging
DC Input	468 (1032)	515 (1135)
AC Input	867 (1912)	958 (2112)

Frame 7 IP00, NEMA/UL Type Open Dimensions

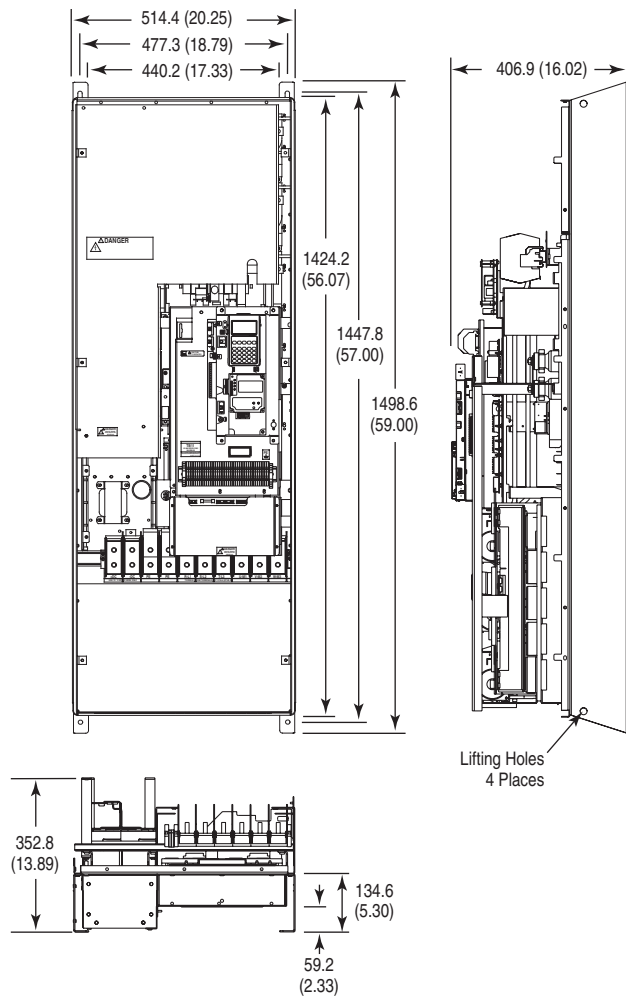

Dimensions are in millimeters and (inches)

Approx. Weight <i>kg (lbs.)</i>	
Drive	Drive & Packaging
147 (324)	173 (382)

Frame 10 IP00, NEMA/UL Type Open

AC Input Shown, for DC Input Dimensions use the Inverter (Left) Bay

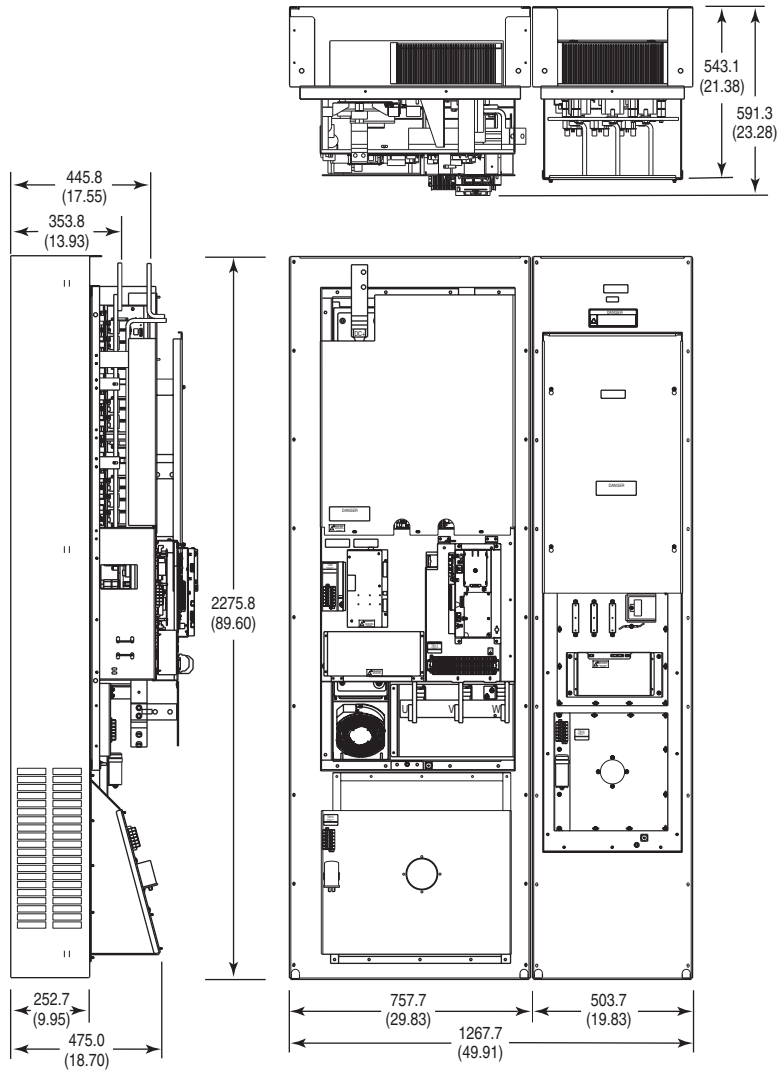

Dimensions are in millimeters and (inches)

Approx. Weight kg (lbs.)		
Type	Drive	Drive & Packaging
DC Input	305 (672)	352 (775)
AC Input	532 (1172)	623 (1372)

Frame 7 Flange Mount Cutout

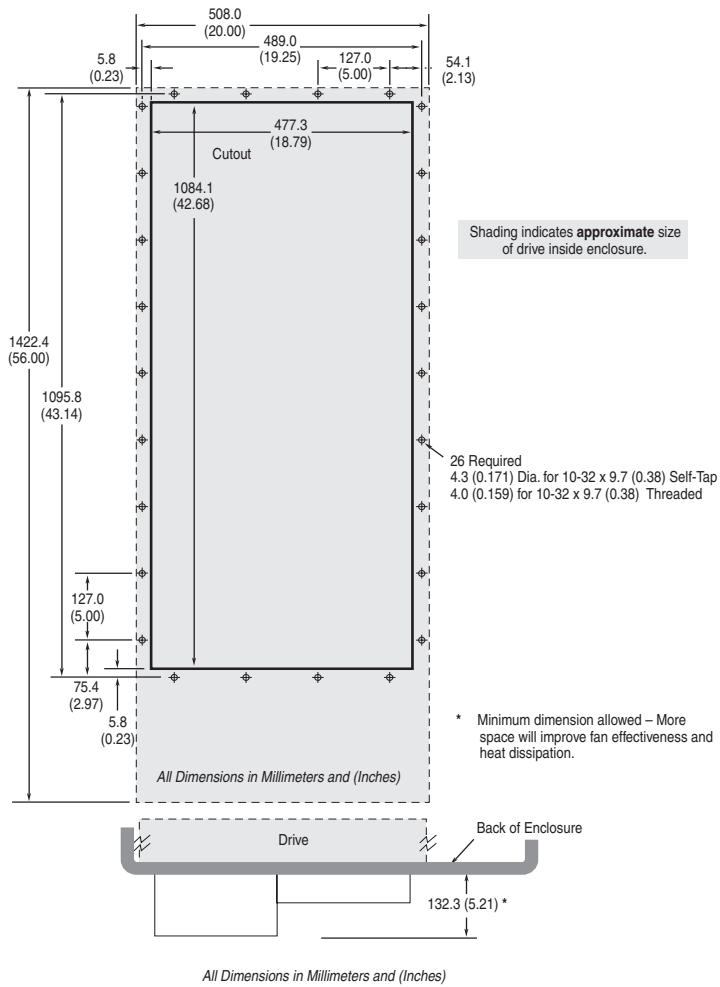

PowerFlex 700 Configured Drives

Product Description

PowerFlex 700 Configured Drives are ideal for global Original Equipment Manufacturers (OEM) and end users with special installation needs. This program simplifies installation and start-up by allowing users to order drive packages that combine operator interface, control, communications and power options in pre-configured assemblies. Designed to meet customer demands for space savings, application flexibility and reliability, Configured PowerFlex 700 AC drives offer a number of commonly requested pre-engineered options, as well as more complex custom-engineered packages.

Benefits

- Simplified installation and start-up by use of common options assembled at the factory.
- Drive functionality exceeds options offered with a standard drive.
- Multiple packaging options specific to customer needs.
- Pre-engineered options for easy order entry, consistent manufacturing, high quality and reduced deliveries.
- Selectable configurations to meet application requirements.

Features

- Standard PowerFlex 700 AC drives and drive-related options.
- Six pulse and multi-pulse.
- Tuned harmonic filters.
- Enclosure options: Type 1, Type 12 (fan and filter or convection/AC), and Type 4 (indoor).
- Pre-engineered options.
- Custom/engineered solutions.
- UL panel recognition from the factory for pre-engineered options.

Options

Refer to the *PowerFlex 700 Configured Drives Tech Data*, publication PFLEX-TD001 for details.

- Drive Input Protection
- Input/Output Contactors
- Input/Output Line Reactors
- Bypass
- Control Power
- Control Interface and Feedback
- Communication
- Human Interface Module (HIM)
- Motor Interface
- Door Mounted Operator Devices

Please contact your local distributor or sales office for product availability.

The Configured Drives Program offers Pre-Engineered, Quick Ship and Custom options.

Pre-Engineered Program

NEMA/UL Type 1

- Panel Mount Drive
- Modular Construction for Floor Standing
- 480V

NEMA/UL Type 12 Fan & Filter

- Panel Mount Drive
- Welded Construction for Wall Mount
- Modular Construction for Floor Standing
- 480V

All Enclosure Types

- Drive Input Protection Options
- Input/Output Contactors
- Bypass Options
- Input/Output Reactor Options
- 115V Control Power Options
- Control Interface and Feedback Options
- Human Interface Modules
- Motor Interface Options
- Operator Devices
- Drawing and Test Options



Description and Approximate Dimensions

Frame (with or without Bypass Option)			Approximate Dimensions	
NEMA/UL Type 1 Catalog Code "A" without Line Reactors	NEMA/UL Type 1 Catalog Code "A" with Line Reactors	NEMA/UL Type 12 Fan & Filter Catalog Code "H" with or without Line Reactors	H x W x D (2) mm (in.)	Style
0 ⁽¹⁾ , 1 ⁽¹⁾ , 2 ⁽¹⁾	0 ⁽¹⁾ , 1 ⁽¹⁾ , 2 ⁽¹⁾	0	965 x 610 x 422 (38.0 x 24.0 x 16.6)	Wall Mount
3	-	-	1016 x 762 x 422 (40.0 x 30.0 x 16.6)	Wall Mount
4	3 ⁽¹⁾	-	1270 x 762 x 422 (50.0 x 30.0 x 16.6)	Wall Mount
-	-	1 & 2	1118 x 610 x 523 (44.0 x 24.0 x 20.6)	Wall Mount
-	-	3	1270 x 762 x 523 (50.0 x 30.0 x 20.6)	Wall Mount
-	4 ⁽¹⁾	-	1422 x 914 x 422 (56.0 x 36.0 x 16.6)	Wall Mount
-	-	4	1422 x 914 x 622 (56.0 x 36.0 x 24.5)	Wall Mount
5	5	5	2200 x 800 x 600 (86.6 x 31.5 x 23.6)	Floor Standing
6	6	6	2200 x 1000 x 600 (86.6 x 39.5 x 23.6)	Floor Standing

(1) Includes vent which requires 127 mm (5 in.) clearance. NEMA/UL Type 1 enclosures for Frames 0-4 do not require fans.
 (2) Depth does not include disconnect handle.



Custom/OEM Specific Package Program

- Meets customer-specific specifications
- All voltage ratings are available

The Allen-Bradley Configured Drives Program allows users to order PowerFlex 700 drive packages that exceed the options offered with a standard drive product. Users can choose from an option list that includes control, power, packaging and documentation to meet unique application demands. The program provides different pre-engineered package sizes based upon environmental and option mounting requirements.

Specifications

Control and Performance

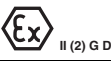
Category	Frames		Specification
	0-6	7-10	
Agency Certification	✓	✓	 Listed to UL508C and CAN/CSA-C2.2 No. 14-M91. Configured drives may be UL508A
	✓		 Marked for all applicable European Directives EMC Directive (2004/108/EC) EN 61800-3 Adjustable Speed electrical power drive systems Low Voltage Directive (2006/95/EC) EN 50178 Electronic Equipment for use in Power Installations
	✓		 Certified to IES 61800-3.
	✓	✓	 Certified to ATEX directive 94/9/EC. Group II Category (2) GD Applications with ATEX Approved Motors.
			The drive is also designed to meet the following specifications:
	✓	✓	NFPA 70 - US National Electrical Code
	✓		NEMA ICS 7.1 - Safety Standards for Construction and Guide for Selection, Installation, and Operation of Adjustable Speed Drive Systems
	✓		IEC 146 - International Electrical Code
	✓		CMAA Specification #70 (Crane Manufacturers of America Association)
	✓		SEMIF47
✓		RINA (Registro Italiano Navale - marine certification)	

Category	Specification									
Protection	Drive	200-208V	240V	380/400V	480V	600V <i>Frames 0-4</i>	600/690V <i>Frames 5-6</i>			
	AC Input Overvoltage Trip:	285VAC	285VAC	570VAC	570VAC	716VAC	818VAC			
	AC Input Undervoltage Trip:	120VAC	138VAC	233VAC	280VAC	345VAC	345VAC			
	Bus Overvoltage Trip:	405VDC	405VDC	810VDC	810VDC	1013VDC	1162VDC			
	Bus Undervoltage Shutoff/Fault:	153VDC	153VDC	305VDC	305VDC	381VDC	437VDC			
	Nominal Bus Voltage:	281VDC	324VDC	540VDC	648VDC	810VDC	932VDC			
	All Drives									
	Heat Sink Thermistor:	Monitored by microprocessor overtemp trip								
	Drive Overcurrent Trip	200% of rated current (typical)								
	Software Overcurrent Trip:	220-300% of rated current (dependent on drive rating)								
	Hardware Overcurrent Trip:									
	Line transients:	up to 6000 volts peak per IEEE C62.41-1991								
	Control Logic Noise Immunity:	Showering arc transients up to 1500V peak								
Power Ride-Thru:	15 milliseconds at full load									
Logic Control Ride-Thru:	0.5 seconds minimum, 2 seconds typical									
Ground Fault Trip:	Phase-to-ground on drive output									
Short Circuit Trip:	Phase-to-phase on drive output									
Environment	Altitude:	1000 m (3300 ft) max. without derating								
	Maximum Surrounding Air Temperature without Derating - IP20, NEMA/UL Type Open:	0 to 50 degrees C (32 to 122 degrees F), typical. See pages 30 through 33 for exceptions. 0 to 40 degrees C (32 to 104 degrees F) for chassis 0 to 65 degrees C (32 to 149 degrees F) for control								
	Storage Temperature (all const.):	-40 to 70 degrees C (-40 to 158 degrees F)								
	Atmosphere:	Important: Drive must not be installed in an area where the ambient atmosphere contains volatile or corrosive gas, vapors or dust. If the drive is not going to be installed for a period of time, it must be stored in an area where it will not be exposed to a corrosive atmosphere.								
	Relative Humidity:	5 to 95% non-condensing								
	Shock:	15G peak for 11ms duration (±1.0 ms)								
	Vibration:	0.152 mm (0.006 in.) displacement, 1G peak								
	Sound:	Frame	Fan Speed	Sound Level	Note: Sound pressure level is measured at 2 meters.					
		0	30 CFM	58 dB						
		1	30 CFM	59 dB						
2		50 CFM	57 dB							
3		120 CFM	61 dB							
4		190 CFM	59 dB							
5		200 CFM	71 dB							
6		300 CFM	72 dB							
7		756 CFM	74 dB							
10 Inverter		1850 CFM	78 dB							
10 Converter	1200 CFM	78 dB								

PowerFlex 700 Technical Data

Category	Specification												
Electrical	Voltage Tolerance:		See page 67 for full power and operating range.										
	Input Frequency Tolerance:		47-63 Hz.										
	Input Phases:		Three-phase input provides full rating for all drives. Single-phase operation provides 50% of rated current. Single phase operation of the drive is not currently rated under the UL 508C listing. Rockwell Automation has verified that single phase operation with output current derated by 50% of the three-phase ratings will meet all safety requirements.										
	Displacement Power Factor:		0.98 across entire speed range.										
	Efficiency:		97.5% at rated amps, nominal line volts.										
	Maximum Short Circuit Rating:		200,000 Amps symmetrical.										
	Actual Short Circuit Rating:		Determined by AIC rating of installed fuse/circuit breaker.										
Control	Method:		Sine coded PWM with programmable carrier frequency. Ratings apply to all drives (refer to the <i>Derating Guidelines</i> in the PowerFlex Reference Manual). The drive can be supplied as 6 pulse or 18 pulse in a configured package.										
	Carrier Frequency:		2, 4, 8 & 10 kHz. Drive rating based on 4 kHz (see pages 30 through 36 for exceptions).										
	Output Voltage Range:		0 to rated motor voltage										
	Output Frequency Range:		Standard Control – 0 to 400 Hz., Vector Control – 0 to 420 Hz										
	Frequency Accuracy		Within ±0.01% of set output frequency.										
	Digital Input:		Within ±0.4% of maximum output frequency.										
	Analog Input:												
	Frequency Control:		Speed Regulation - w/Slip Compensation (Volts per Hertz Mode)		Standard								
			0.5% of base speed across 40:1 speed range		Vector								
			40:1 operating range 10 rad/sec bandwidth										
			Speed Regulation - w/Slip Compensation (Sensorless Vector Mode)		Standard								
			0.5% of base speed across 80:1 speed range		Vector								
			80:1 operating range 20 rad/sec bandwidth										
			Speed Regulation - w/Feedback (Sensorless Vector Mode)		Vector								
			0.1% of base speed across 80:1 speed range										
			80:1 operating range 20 rad/sec bandwidth										
	Speed Control:		Speed Regulation - w/o Feedback (Vector Control Mode)		Vector								
0.1% of base speed across 120:1 speed range													
		120:1 operating range 50 rad/sec bandwidth											
		Speed Regulation - w/Feedback (Vector Control Mode)		Vector									
		0.001% of base speed across 120:1 speed range											
		1000:1 operating range 250 rad/sec bandwidth											
Torque Regulation:		Torque Regulation - w/o Feedback ±5%, 600 rad/sec bandwidth		Vector									
		Torque Regulation - w/Feedback ±2%, 2500 rad/sec bandwidth		Vector									
Selectable Motor Control:		Sensorless Vector with full tuning. Standard V/Hz with full custom capability. PF700 adds Vector Control.											
Stop Modes:		Multiple programmable stop modes including - Ramp, Coast, DC-Brake, Ramp-to-Hold and S-curve.											
Accel/Decel:		Two independently programmable accel and decel times. Each time may be programmed from 0 - 3600 seconds in 0.1 second increments.											
Intermittent Overload:		110% Overload capability for up to 1 minute 150% Overload capability for up to 3 seconds											
Current Limit Capability:		Proactive Current Limit programmable from 20 to 160% of rated output current. Independently programmable proportional and integral gain.											
Electronic Motor Overload Protection:		Class 10 protection with speed sensitive response. Investigated by U.L. to comply with N.E.C. Article 430. U.L. File E59272, volume 12.											
Digital/Analog Input Latency		Signal		Motor Control		Latency							
						Min.		Max		Typical			
		Digital Input		Start		FVC		8.4 ms		10.4 ms		8.4 ms	
						SVC		9.2 ms		16.0 ms		9.2 ms	
				Stop		FVC		10.0 ms		12.4 ms		10.4 ms	
						SVC		10.0 ms		12.0 ms		10.4 ms	
		Analog Input		Torque (at 4 kHz PWM)		FVC		772 µs		1.06 ms		840 µs	
Torque (at 2 kHz PWM)				FVC		1.008 ms		1.46 ms		1.256 ms			
Speed				FVC		4.6 ms		8.6 ms		4.8 ms			
				SVC		4.8 ms		12.4 ms		6.4 ms			
Encoder	Type:		Incremental, dual channel										
	Supply:		12V, 250 mA. 12V, 10 mA minimum inputs isolated with differential transmitter, 250 kHz maximum.										
	Quadrature:		90°, ±27 degrees at 25 degrees C.										
	Duty Cycle:		50%, +10%										
	Requirements:		Encoders must be line driver type, quadrature (dual channel) or pulse (single channel), 8-15V DC output (4-6V DC when jumpers are in 5V position), single-ended or differential and capable of supplying a minimum of 10 mA per channel. Maximum input frequency is 250 kHz. The Encoder Interface Board accepts 12V DC square-wave with a minimum high state voltage of 7.0V DC. With the jumpers in the 5V position, the encoder will accept a 5V DC square-wave with a minimum high state voltage of 3.0V DC. In either jumper position, the maximum low state voltage is 0.4V DC.										

Watts Loss (Rated Load, Speed & PWM)⁽¹⁾

IP20, NEMA/UL Type 1 – Frames 0-6

Voltage	ND HP/kW	External Watts	Internal Watts	Total Watts Loss
240V	0.5	9	37	46
	1	22	39	61
	2	38	39	77
	3	57	41	98
	5	97	82	179
	7.5	134	74	208
	10	192	77	269
	15	276	92	368
	20	354	82	436
	25	602	96	698
	30	780	96	876
	40	860	107	967
	50	1132	138	1270
	60	1296	200	1496
75	1716	277	1993	
100	1837	418	2255	
400V	0.37	11	42	53
	0.75	19	44	63
	1.5	31	45	76
	2.2	46	46	93
	4	78	87	164
	5.5	115	79	194
	7.5	134	84	218
	11	226	99	326
	15	303	91	394
	18.5	339	102	441
	22	357	103	459
	30	492	117	610
	37	568	148	717
	45	722	207	930
	55	821	286	1107
	55	1130	397	1527
	90	1402	443	1845
	110	1711	493	2204
132	1930	583	2513	
480V	0.5	11	42	53
	1	19	44	63
	2	31	45	76
	3	46	46	93
	5	78	87	164
	7.5	115	79	194
	10	134	84	218
	15	226	99	326
	20	303	91	394
	25	339	102	441
	30	357	103	459
	40	492	117	610
	50	568	148	717
	60	722	207	930
	75	821	286	1107
	100	1130	397	1527
125	1402	443	1845	
150	1711	493	2204	
200	1930	583	2513	
600V	0.5	9	37	46
	1	14	40	54
	2	25	40	65
	3	41	42	83
	5	59	83	142
	7.5	83	75	157
	10	109	77	186
	15	177	93	270
	20	260	83	343
	25	291	95	385
	30	324	95	419
	40	459	109	569
	50	569	141	710
	60	630	195	825
	75	1053	308	1361
	100	1467	407	1874
125	1400	500	1900	
150	1668	612	2280	

IP54, NEMA/UL Type 12 – Frames 0-6

Voltage	ND HP	External Watts	Internal Watts	Total Watts Loss
480V	75	873	234	1107
	100	1237	290	1527
	125	1563	282	1845
	150	1874	330	2204
	200	2100	413	2513
600V	75	1091	270	1361
	100	1537	337	1874
	125	1584	316	1900
	150	1895	385	2280

IP20, NEMA/UL Type 1 – Frames 7-10

Voltage	Frame	HP Rating		Dissipation (Watts)					
		ND	HD	AC Input			DC Input		
				External	Internal	Total	External	Internal	Total
400/480V	7	250	200	3422	514	3936	3098	497	3595
		250	250	4224	618	4842	3848	599	4447
	8	300	250	3125	569	3694	2698	547	3245
		350	300	3588	681	4269	3091	655	3746
		400	350	4284	336	4620	3692	305	3997
		450	400	4850	1000	5850	4178	965	5143
		500	450	5278	2010	7288	4506	1969	6475
		600	500	6772	2675	9447	5457	2606	8063
	9	600	500	6772	2675	9447	5457	2606	8063
		700	600	8595	2339	10934	7470	2280	9750
	10	700	600	8595	2339	10934	7470	2280	9750

(1) Worst case condition including Vector Control board, HIM and Communication Module.

Voltage Tolerance

Drive Rating	Nominal Line Voltage	Nominal Motor Voltage	Drive Full Power Range	Drive Operating Range
200-240	200	200*	200-264	180-264
	208	208	208-264	
	240	230	230-264	
380-480	380	380*	380-528	342-528
	400	400	400-528	
	480	460	460-528	
500-600 (Frames 0-4 Only)	600	575*	575-660	432-660
500-690 (Frames 5 & 6 Only)	600	575*	575-660	475-759
	690	690	690-759	475-759

Drive Full Power Range = Nominal Motor Voltage to Drive Rated Voltage +10%.
 Rated current is available across the entire Drive Full Power Range

Drive Operating Range = Lowest* Nominal Motor Voltage -10% to Drive Rated Voltage +10%.
 Drive Output is linearly derated when Actual Line Voltage is less than the Nominal Motor Voltage

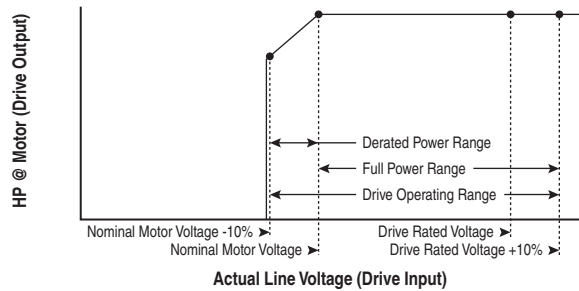

Example:

Calculate the maximum power of a 5 HP, 460V motor connected to a 480V rated drive supplied with 342V Actual Line Voltage input.

- Actual Line Voltage / Nominal Motor Voltage = 74.3%
- 74.3% × 5 HP = 3.7 HP
- 74.3% × 60 Hz = 44.6 Hz

At 342V Actual Line Voltage, the maximum power the 5 HP, 460V motor can produce is 3.7 HP at 44.6 Hz.

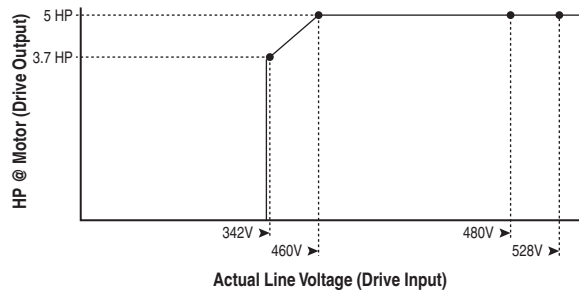

Derating Guidelines

Altitude and Efficiency

Frame	Type	Derate
All	Altitude	
	Efficiency (typical)	

Ambient Temperature/Load

240V AC

PowerFlex 700 Power Rating		Derating
ND HP	HD HP	--- 2 kHz - - - - 4 kHz — 6 kHz - - - - 8 kHz — 10 kHz
240 Volt		
0.5 - 5.0	0.33 - 3.0	None
7.5	5.0	
10 - 15	7.5 - 10	None
20	15	
25	20	

PowerFlex 700 Technical Data

PowerFlex 700 Power Rating		Derating
ND HP	HD HP	
240 Volt		
30	25	
40	30	
50	40	
60	50	
75	60	
100	75	

400V AC

PowerFlex 700 Power Rating		Derating
ND kW	HD kW	
400 Volt		
0.37 - 7.5	0.25 - 5.5	None
11	7.5	
15	11	
18.5	15	
22	18.5	None
30	22	
37	30	
45	37	

PowerFlex 700 Technical Data

PowerFlex 700 Power Rating		Derating
ND kW	HD kW	
400 Volt		
55	45	<p>Derating graph for 55 kW ND and 45 kW HD at 400V. The y-axis is Max Ambient Temp (°C) from 20 to 50. The x-axis is % of Rated Continuous Current from 40 to 100. The 10 kHz curve (solid black) starts at 50°C and drops to 40°C at 90% current. The 8 kHz curve (dashed orange) starts at 50°C and drops to 40°C at 100% current. The 6 kHz curve (solid green) starts at 50°C and drops to 40°C at 100% current. The 4 kHz curve (dotted blue) starts at 50°C and drops to 40°C at 100% current. The 2 kHz curve (dashed red) starts at 50°C and drops to 40°C at 100% current.</p>
75	55	<p>Derating graph for 75 kW ND and 55 kW HD at 400V. The y-axis is Max Ambient Temp (°C) from 20 to 50. The x-axis is % of Rated Continuous Current from 40 to 100. The 10 kHz curve (solid black) starts at 50°C and drops to 20°C at 70% current. The 8 kHz curve (dashed orange) starts at 50°C and drops to 20°C at 80% current. The 6 kHz curve (solid green) starts at 50°C and drops to 20°C at 90% current. The 4 kHz curve (dotted blue) starts at 50°C and drops to 20°C at 100% current. The 2 kHz curve (dashed red) starts at 50°C and drops to 20°C at 100% current.</p>
90	75	<p>Derating graph for 90 kW ND and 75 kW HD at 400V. The y-axis is Max Ambient Temp (°C) from 20 to 50. The x-axis is % of Rated Continuous Current from 40 to 100. The 10 kHz curve (solid black) starts at 50°C and drops to 20°C at 100% current. The 8 kHz curve (dashed orange) starts at 50°C and drops to 20°C at 100% current. The 6 kHz curve (solid green) starts at 50°C and drops to 20°C at 100% current. The 4 kHz curve (dotted blue) starts at 50°C and drops to 20°C at 100% current. The 2 kHz curve (dashed red) starts at 50°C and drops to 20°C at 100% current.</p>
110	90	<p>Derating graph for 110 kW ND and 90 kW HD at 400V. The y-axis is Max Ambient Temp (°C) from 20 to 50. The x-axis is % of Rated Continuous Current from 40 to 100. The 10 kHz curve (solid black) starts at 40°C and drops to 20°C at 70% current. The 8 kHz curve (dashed orange) starts at 40°C and drops to 20°C at 80% current. The 6 kHz curve (solid green) starts at 40°C and drops to 20°C at 90% current. The 4 kHz curve (dotted blue) starts at 40°C and drops to 20°C at 100% current. The 2 kHz curve (dashed red) starts at 40°C and drops to 20°C at 100% current.</p>
132	110	<p>Derating graph for 132 kW ND and 110 kW HD at 400V. The y-axis is Max Ambient Temp (°C) from 20 to 50. The x-axis is % of Rated Continuous Current from 40 to 100. The 10 kHz curve (solid black) starts at 45°C and drops to 20°C at 70% current. The 8 kHz curve (dashed orange) starts at 45°C and drops to 20°C at 80% current. The 6 kHz curve (solid green) starts at 45°C and drops to 20°C at 90% current. The 4 kHz curve (dotted blue) starts at 45°C and drops to 20°C at 100% current. The 2 kHz curve (dashed red) starts at 45°C and drops to 20°C at 100% current.</p>
160	150	<p>Derating graph for 160 kW ND and 150 kW HD at 400V. The y-axis is Max Ambient Temp (°C) from 20 to 50. The x-axis is % of Rated Continuous Current from 40 to 100. The 10 kHz curve (solid black) starts at 50°C and drops to 20°C at 80% current. The 8 kHz curve (dashed orange) starts at 50°C and drops to 20°C at 90% current. The 6 kHz curve (solid green) starts at 50°C and drops to 20°C at 100% current. The 4 kHz curve (dotted blue) starts at 50°C and drops to 20°C at 100% current. The 2 kHz curve (dashed red) starts at 50°C and drops to 20°C at 100% current.</p>

480V AC

PowerFlex 700 Power Rating		Derating
ND HP	HD HP	
480 Volt		
0.5 - 10	0.33 - 7.5	None
15	10	
20	15	
25	20	
30	25	None
40	30	
50	40	
60	50	

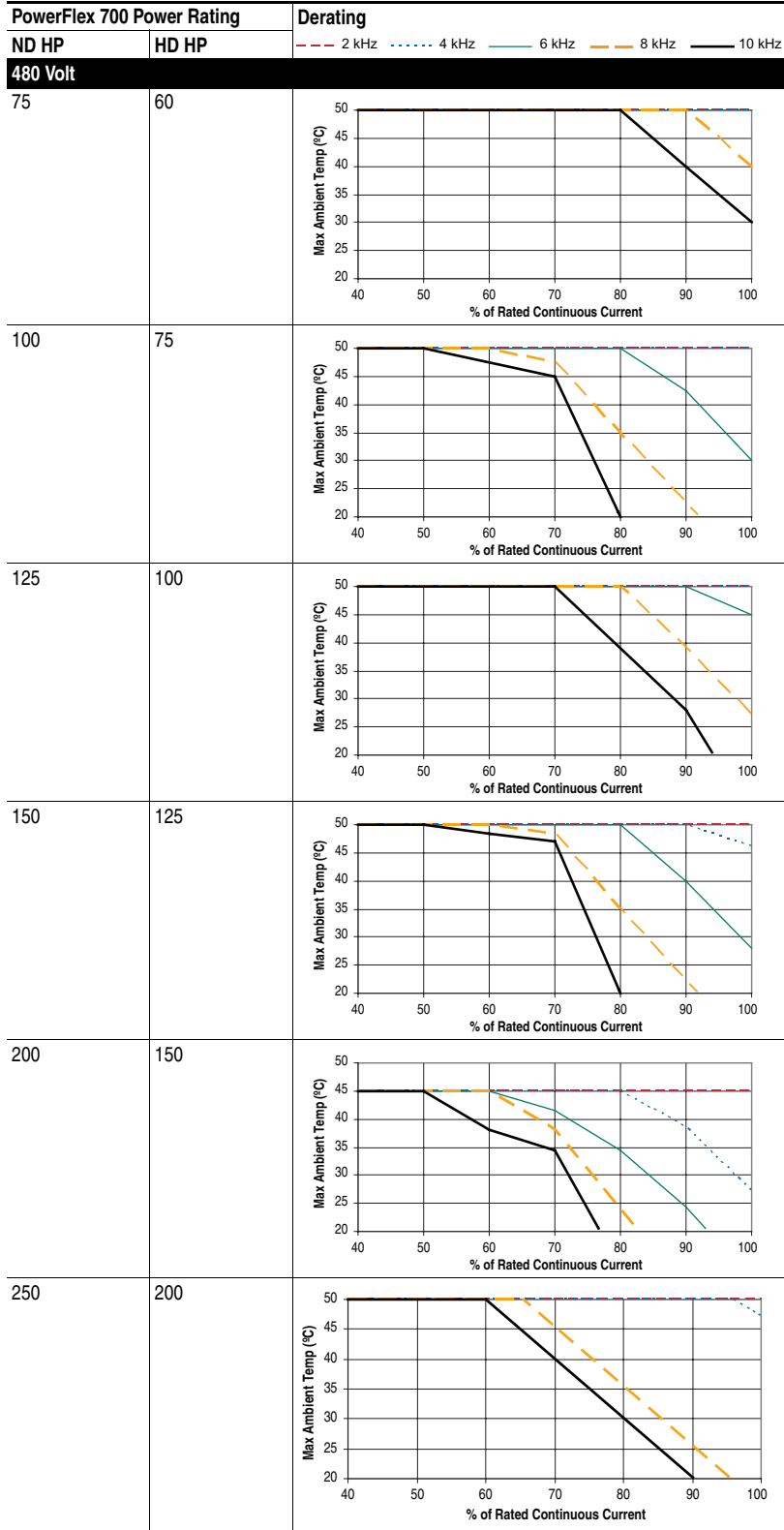

PowerFlex 700 Technical Data

PowerFlex 700 Power Rating		Derating										
ND HP	HD HP											
480 Volt												
700	600	<table border="1"> <caption>PWM Carrier Frequency vs % of Rated Continuous Current (480 Volt)</caption> <thead> <tr> <th>% of Rated Continuous Current</th> <th>PWM Carrier Frequency (kHz)</th> </tr> </thead> <tbody> <tr> <td>60</td> <td>8</td> </tr> <tr> <td>70</td> <td>6</td> </tr> <tr> <td>80</td> <td>4</td> </tr> <tr> <td>100</td> <td>2</td> </tr> </tbody> </table>	% of Rated Continuous Current	PWM Carrier Frequency (kHz)	60	8	70	6	80	4	100	2
% of Rated Continuous Current	PWM Carrier Frequency (kHz)											
60	8											
70	6											
80	4											
100	2											

600V AC

PowerFlex 700 Power Rating		Derating																																																
ND HP	HD HP																																																	
600 Volt																																																		
1.0 - 2.0	0.5 - 1.0	None																																																
3.0	2.0	<table border="1"> <caption>Max Ambient Temp vs % of Rated Continuous Current (600V AC, 3.0 HP)</caption> <thead> <tr> <th>% of Rated Continuous Current</th> <th>2 kHz (°C)</th> <th>4 kHz (°C)</th> <th>6 kHz (°C)</th> <th>8 kHz (°C)</th> <th>10 kHz (°C)</th> </tr> </thead> <tbody> <tr> <td>40</td> <td>50</td> <td>50</td> <td>50</td> <td>50</td> <td>45</td> </tr> <tr> <td>50</td> <td>50</td> <td>50</td> <td>50</td> <td>49</td> <td>42</td> </tr> <tr> <td>60</td> <td>50</td> <td>50</td> <td>50</td> <td>48</td> <td>38</td> </tr> <tr> <td>70</td> <td>50</td> <td>50</td> <td>50</td> <td>46</td> <td>34</td> </tr> <tr> <td>80</td> <td>50</td> <td>50</td> <td>50</td> <td>44</td> <td>30</td> </tr> <tr> <td>90</td> <td>50</td> <td>50</td> <td>50</td> <td>42</td> <td>26</td> </tr> <tr> <td>100</td> <td>50</td> <td>50</td> <td>50</td> <td>40</td> <td>22</td> </tr> </tbody> </table>	% of Rated Continuous Current	2 kHz (°C)	4 kHz (°C)	6 kHz (°C)	8 kHz (°C)	10 kHz (°C)	40	50	50	50	50	45	50	50	50	50	49	42	60	50	50	50	48	38	70	50	50	50	46	34	80	50	50	50	44	30	90	50	50	50	42	26	100	50	50	50	40	22
% of Rated Continuous Current	2 kHz (°C)	4 kHz (°C)	6 kHz (°C)	8 kHz (°C)	10 kHz (°C)																																													
40	50	50	50	50	45																																													
50	50	50	50	49	42																																													
60	50	50	50	48	38																																													
70	50	50	50	46	34																																													
80	50	50	50	44	30																																													
90	50	50	50	42	26																																													
100	50	50	50	40	22																																													
5.0	3.0	<table border="1"> <caption>Max Ambient Temp vs % of Rated Continuous Current (600V AC, 5.0 HP)</caption> <thead> <tr> <th>% of Rated Continuous Current</th> <th>2 kHz (°C)</th> <th>4 kHz (°C)</th> <th>6 kHz (°C)</th> <th>8 kHz (°C)</th> <th>10 kHz (°C)</th> </tr> </thead> <tbody> <tr> <td>40</td> <td>50</td> <td>50</td> <td>50</td> <td>50</td> <td>48</td> </tr> <tr> <td>50</td> <td>50</td> <td>50</td> <td>50</td> <td>49</td> <td>44</td> </tr> <tr> <td>60</td> <td>50</td> <td>50</td> <td>50</td> <td>48</td> <td>40</td> </tr> <tr> <td>70</td> <td>50</td> <td>50</td> <td>50</td> <td>46</td> <td>36</td> </tr> <tr> <td>80</td> <td>50</td> <td>50</td> <td>50</td> <td>44</td> <td>32</td> </tr> <tr> <td>90</td> <td>50</td> <td>50</td> <td>50</td> <td>42</td> <td>28</td> </tr> <tr> <td>100</td> <td>50</td> <td>50</td> <td>50</td> <td>40</td> <td>24</td> </tr> </tbody> </table>	% of Rated Continuous Current	2 kHz (°C)	4 kHz (°C)	6 kHz (°C)	8 kHz (°C)	10 kHz (°C)	40	50	50	50	50	48	50	50	50	50	49	44	60	50	50	50	48	40	70	50	50	50	46	36	80	50	50	50	44	32	90	50	50	50	42	28	100	50	50	50	40	24
% of Rated Continuous Current	2 kHz (°C)	4 kHz (°C)	6 kHz (°C)	8 kHz (°C)	10 kHz (°C)																																													
40	50	50	50	50	48																																													
50	50	50	50	49	44																																													
60	50	50	50	48	40																																													
70	50	50	50	46	36																																													
80	50	50	50	44	32																																													
90	50	50	50	42	28																																													
100	50	50	50	40	24																																													
7.5	5.0	<table border="1"> <caption>Max Ambient Temp vs % of Rated Continuous Current (600V AC, 7.5 HP)</caption> <thead> <tr> <th>% of Rated Continuous Current</th> <th>2 kHz (°C)</th> <th>4 kHz (°C)</th> <th>6 kHz (°C)</th> <th>8 kHz (°C)</th> <th>10 kHz (°C)</th> </tr> </thead> <tbody> <tr> <td>40</td> <td>50</td> <td>50</td> <td>45</td> <td>33</td> <td>21</td> </tr> <tr> <td>50</td> <td>50</td> <td>50</td> <td>43</td> <td>30</td> <td>19</td> </tr> <tr> <td>60</td> <td>50</td> <td>50</td> <td>41</td> <td>27</td> <td>17</td> </tr> <tr> <td>70</td> <td>50</td> <td>50</td> <td>39</td> <td>25</td> <td>15</td> </tr> <tr> <td>80</td> <td>50</td> <td>50</td> <td>37</td> <td>23</td> <td>13</td> </tr> <tr> <td>90</td> <td>50</td> <td>50</td> <td>35</td> <td>21</td> <td>11</td> </tr> <tr> <td>100</td> <td>50</td> <td>50</td> <td>33</td> <td>19</td> <td>9</td> </tr> </tbody> </table>	% of Rated Continuous Current	2 kHz (°C)	4 kHz (°C)	6 kHz (°C)	8 kHz (°C)	10 kHz (°C)	40	50	50	45	33	21	50	50	50	43	30	19	60	50	50	41	27	17	70	50	50	39	25	15	80	50	50	37	23	13	90	50	50	35	21	11	100	50	50	33	19	9
% of Rated Continuous Current	2 kHz (°C)	4 kHz (°C)	6 kHz (°C)	8 kHz (°C)	10 kHz (°C)																																													
40	50	50	45	33	21																																													
50	50	50	43	30	19																																													
60	50	50	41	27	17																																													
70	50	50	39	25	15																																													
80	50	50	37	23	13																																													
90	50	50	35	21	11																																													
100	50	50	33	19	9																																													
10	7.5	<table border="1"> <caption>Max Ambient Temp vs % of Rated Continuous Current (600V AC, 10 HP)</caption> <thead> <tr> <th>% of Rated Continuous Current</th> <th>2 kHz (°C)</th> <th>4 kHz (°C)</th> <th>6 kHz (°C)</th> <th>8 kHz (°C)</th> <th>10 kHz (°C)</th> </tr> </thead> <tbody> <tr> <td>40</td> <td>50</td> <td>50</td> <td>50</td> <td>50</td> <td>50</td> </tr> <tr> <td>50</td> <td>50</td> <td>50</td> <td>50</td> <td>50</td> <td>48</td> </tr> <tr> <td>60</td> <td>50</td> <td>50</td> <td>50</td> <td>49</td> <td>45</td> </tr> <tr> <td>70</td> <td>50</td> <td>50</td> <td>50</td> <td>48</td> <td>42</td> </tr> <tr> <td>80</td> <td>50</td> <td>50</td> <td>50</td> <td>46</td> <td>38</td> </tr> <tr> <td>90</td> <td>50</td> <td>50</td> <td>50</td> <td>44</td> <td>34</td> </tr> <tr> <td>100</td> <td>50</td> <td>50</td> <td>50</td> <td>42</td> <td>30</td> </tr> </tbody> </table>	% of Rated Continuous Current	2 kHz (°C)	4 kHz (°C)	6 kHz (°C)	8 kHz (°C)	10 kHz (°C)	40	50	50	50	50	50	50	50	50	50	50	48	60	50	50	50	49	45	70	50	50	50	48	42	80	50	50	50	46	38	90	50	50	50	44	34	100	50	50	50	42	30
% of Rated Continuous Current	2 kHz (°C)	4 kHz (°C)	6 kHz (°C)	8 kHz (°C)	10 kHz (°C)																																													
40	50	50	50	50	50																																													
50	50	50	50	50	48																																													
60	50	50	50	49	45																																													
70	50	50	50	48	42																																													
80	50	50	50	46	38																																													
90	50	50	50	44	34																																													
100	50	50	50	42	30																																													

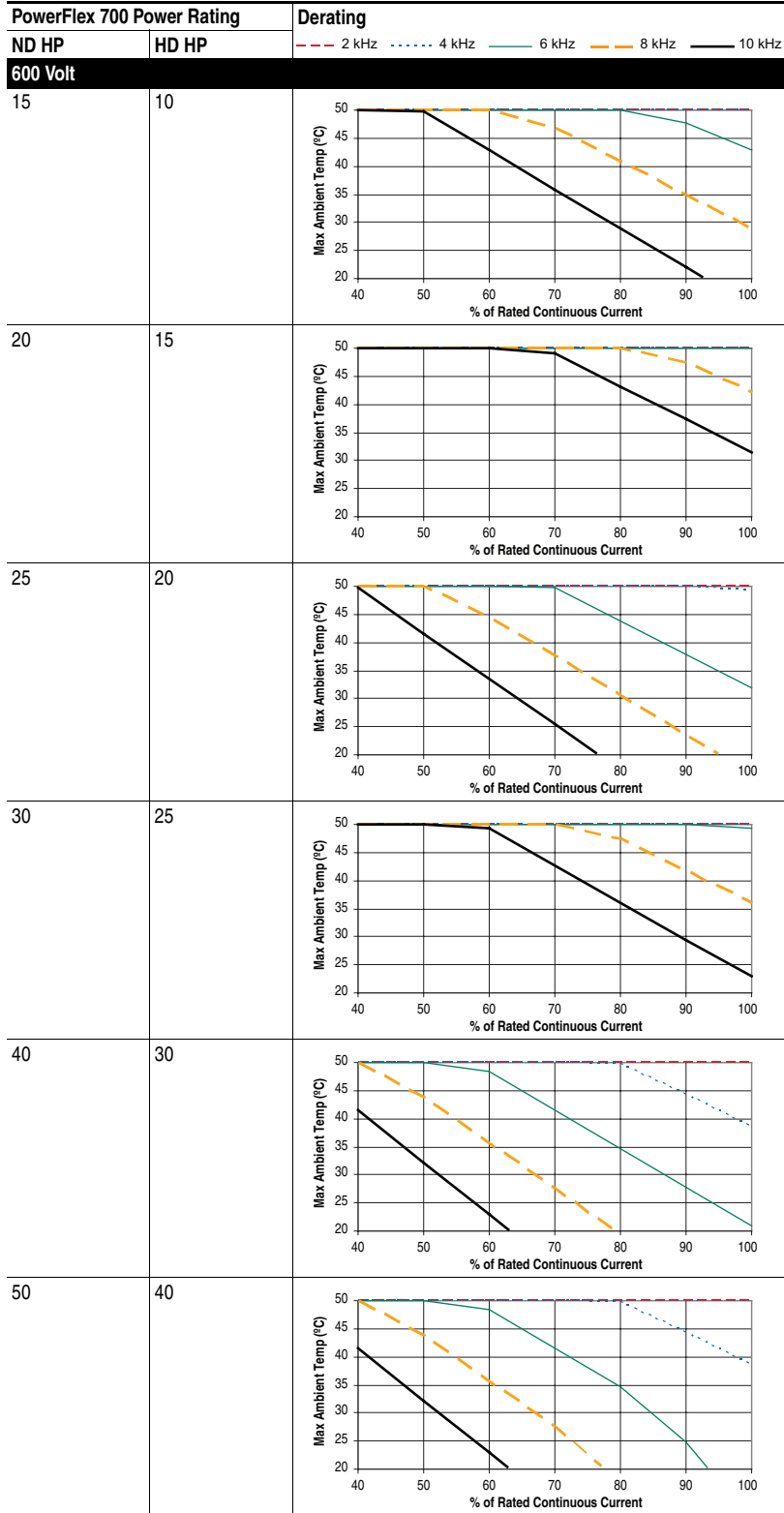

PowerFlex 700 Technical Data

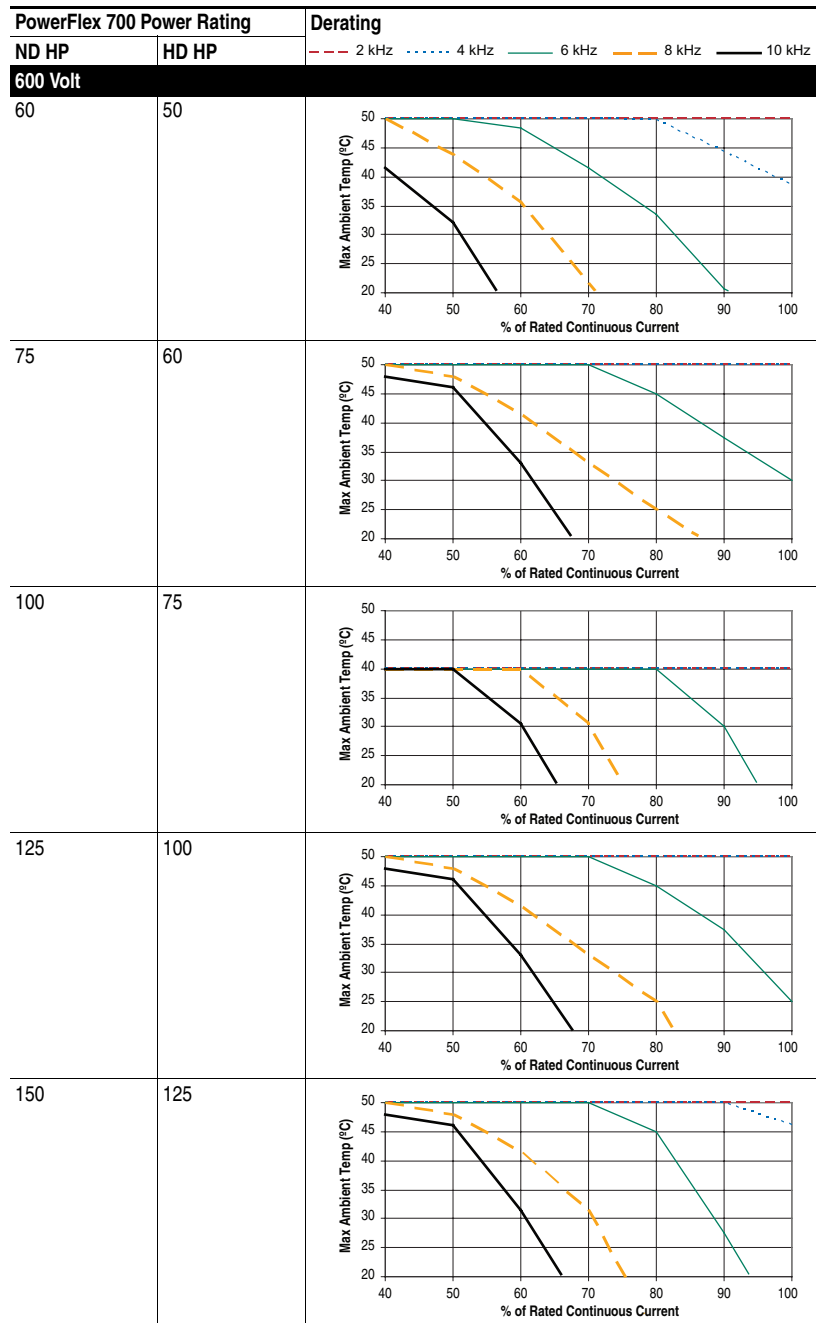

690V AC

PowerFlex 700 Power Rating		Derating
ND kW	HD kW	
690 Volt		
45 - 55	37.5 - 45	None
75	55	
90	75	
110	90	
132	110	

650V DC

PowerFlex 700 Power Rating		Derating
ND kW	HD kW	
650 Volt DC Input		
700	600	

Notes

Notes

PowerFlex, Zero Stacking, Force Technology, DriveExplorer, DriveTools SP, DPI and PanelView are trademarks of Rockwell Automation.
Trademarks not belonging to Rockwell Automation are property of their respective companies.

www.rockwellautomation.com

Power, Control and Information Solutions Headquarters

Americas: Rockwell Automation, 1201 South Second Street, Milwaukee, WI 53204 USA, Tel: (1) 414.382.2000, Fax: (1) 414.382.4444

Europe/Middle East/Africa: Rockwell Automation, Vorstlaan/Boulevard du Souverain 36, 1170 Brussels, Belgium, Tel: (32) 2 663 0600, Fax: (32) 2 663 0640

Asia Pacific: Rockwell Automation, Level 14, Core F, Cyberport 3, 100 Cyberport Road, Hong Kong, Tel: (852) 2887 4788, Fax: (852) 2508 1846