

Programmable Current Limit Switch with Over-Voltage Protection

Features

- Wide input voltage range from 3V to 6.8V
- Maximum input voltage is 32V
- Integrated low $R_{ds(on)}$ switch: 105m Ω
- Programmable current limit from 100mA to 1.5A
 - 1.5A with 10% Accuracy
- 6.8V input over-voltage shut-off
- OVP response time: less than 1 μ s
- 5.8V output clamp voltage
- Thermal shutdown protection
- FCDFN 1mmX1mm-4L

Applications

- White goods, Appliances
- Set-top boxes, DVD and Gaming consoles
- Adapter power devices
- Smart meters, Gas analyzers
- Smart load switches/USB switches

General Description

AWP35021 is a smart e-Fuse with robust over-current and over-voltage protection. The wide operating voltage allows control of many popular DC buses.

AWP35021 uses N-channel MOSFET as power switch, and allows the user to program the current-limit threshold between 100mA to 1.5A with an external resistor.

AWP35021 can withstand 32V DC voltage. In the events that an incorrect voltage is IN, the output voltage clamps to 5.8V to protect the load. If the voltage at IN exceeds 6.8V, the device disconnects the load to prevent damage to the device and load.

Additional features include under-voltage and over-temperature are provided to monitor system status.

Typical Application Circuit

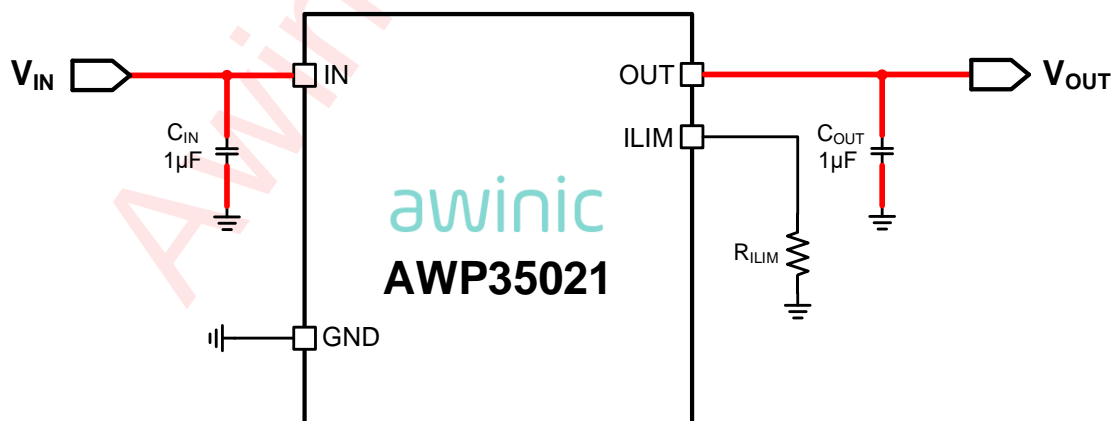

Figure 1 Typical Application Circuit

Pin Configuration And Top Mark

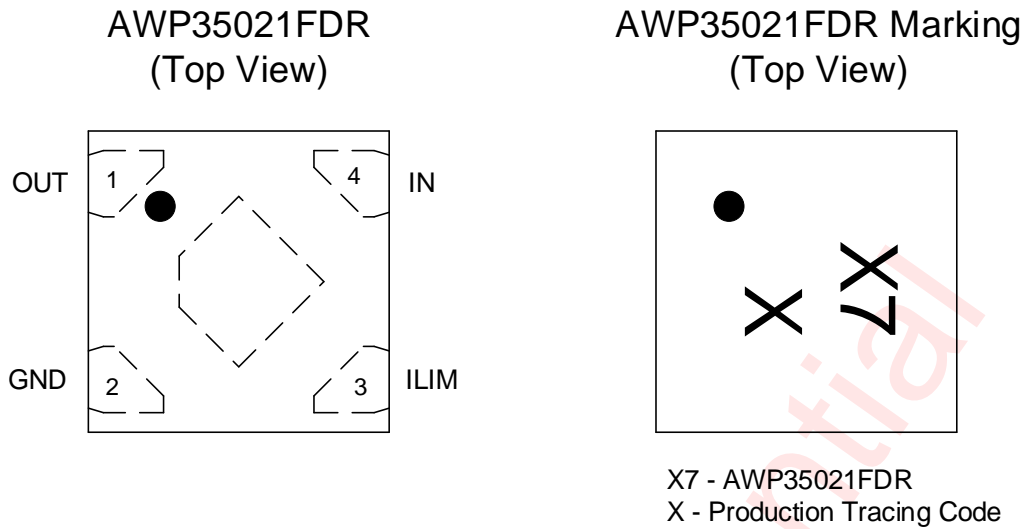

Figure 2 Pin Configuration

Pin Definition

No.	NAME	DESCRIPTION
1	OUT	Power output.
2	GND	Ground.
3	ILIM	An external resistor R_{ILIM} from this pin to GND. Setting current limit threshold, The calculation formula is as follows $I_{LIM} = 25 / R_{ILIM} (A)$ where R_{ILIM} is in $k\Omega$. Recommended $16.6 k\Omega \leq R_{ILIM} \leq 250 k\Omega$.
4	IN	Power input. Supply voltage of the device.
	Thermal pad	Connect Thermal PAD to GND terminal externally, used to heat-sink the part to the circuit board traces.

Functional Block Diagram

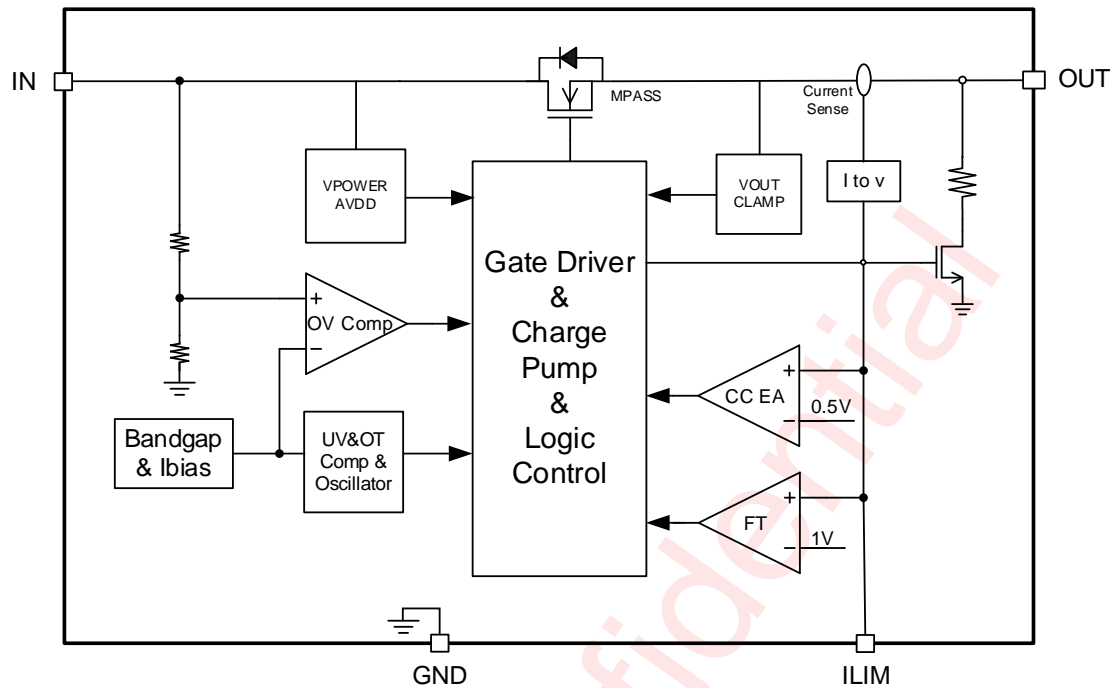

Figure 3 Functional Block Diagram

Typical Application Circuits

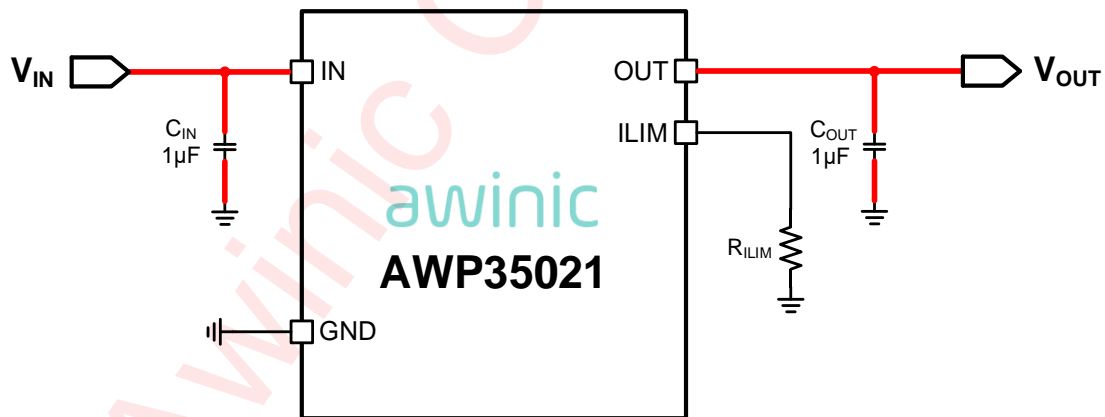

Figure 4 Application Circuit

Notice for typical application circuits:

1. All peripheral devices should be as close as possible to the chip, C_{IN} , C_{OUT} should be close to V_{IN} , V_{OUT} pins respectively. Besides the metal traces between them should be short and wide.
2. The traces routing the R_{ILIM} resistor to the device must be as short as possible to reduce parasitic effects on the current limit accuracy.
3. IN, OUT support 1.5A current, the routing lines should be as wide as possible.
4. The Thermal PAD must be directly connected to PCB ground plane using wide and short copper trace.

Ordering Information

Part Number	Temperature	Package	Marking	Moisture Sensitivity Level	Environmental Information	Delivery Form
AWP35021FDR	-40°C to 85°C	FCDFN 1mmX1mm-4L	X7	MSL1	ROHS+HF	9000 units/ Tape and Reel

Absolute Maximum Ratings^(NOTE1)

PARAMETERS		RANGE
Input voltage range	IN	-0.3V to 32V
	ILIM	-0.3V to 6V
Output voltage range	OUT	-0.3V to 7V
Junction-to-ambient thermal resistance θ_{JA} ^(NOTE2)		234.3°C/W
Maximum operating junction temperature T_{JMAX}		150°C
Storage temperature T_{STG}		-65°C to 150°C
Lead temperature (soldering 10 seconds)		260°C
ESD and Latch-Up		
HBM (Human Body Model) ^(NOTE3)		±2kV
CDM ^(NOTE4)		±1.5kV
Latch-Up ^(NOTE5)		±200mA

NOTE1: Conditions out of those ranges listed in “absolute maximum ratings” may cause permanent damages to the device. In spite of the limits above, functional operation conditions of the device should within the ranges listed in “recommended operating conditions”. Exposure to absolute-maximum-rated conditions for prolonged periods may affect device reliability.

NOTE2: Thermal resistance from junction to ambient is highly dependent on PCB layout.

NOTE3: The human body model is a 100pF capacitor discharged through a 1.5kΩ resistor into each pin.
Test method: ESDA/JEDEC JS-001-2017

NOTE4: Test method: ESDA/JEDEC JS-002-2018

NOTE5: Test method: JESD78E

Recommended Operating Conditions

Symbol	Parameter	Min.	Typ.	Max.	Unit
V_{IN}	Power voltage	3		6.8	V
V_{ILIM}	Input/output voltage	0		5.5	V
I_{OUT}	Current limit	0.1		1.5	A
T_A	Ambient temperature	-40		85	°C
R_{ILIM}	Current-limit set resistor	16.6		250	kΩ
C_{IN}	Input capacitor	0.1	1	100	μF
C_{OUT}	Output capacitor	1		100	μF

Awinic Confidential

Electrical Characteristics

$T_A = 25^\circ\text{C}$, $V_{IN} = 5\text{V}$, $R_{LIM} = 25\text{k}\Omega$, $C_{IN} = 1\mu\text{F}$, $C_{OUT} = 1\mu\text{F}$, unless otherwise noted.

PARAMETER	TEST CONDITION	MIN	TYP	MAX	UNIT		
INPUT VOLTAGES and CURRENTS							
V_{IN_RNG}	V_{IN} supply voltage range	3		6.8	V		
V_{IN_UVLO}	Under-voltage lockout threshold	V_{IN} rising	2.6	2.75	2.9	V	
		V_{IN} falling	2.45	2.6	2.75	V	
I_Q	V_{IN} supply current	$V_{IN} = 5\text{V}$, $I_{OUT} = 0\text{mA}$		170	230	μA	
t_{DEG}	V_{IN} power on deglitch time		8	12	ms		
OVER-VOLTAGE PROTECTION							
V_{IN_OVLO}	OVP threshold voltage	V_{IN} rising	6.5	6.8	7.1	V	
		Hysteresis		120		mV	
$t_{OVP_REC_DEG}$	OVP recovery deglitch time		8	12	ms		
t_{OFF}	OVP turn off response time	$C_{OUT} = 1\mu\text{F}$, $R_L = 100\Omega$, $V_{IN} > V_{IN_OVLO}$ to V_{OUT} stop rising, V_{IN} rise at $3\text{V}/\mu\text{s}$		200		ns	
V_{OVC}	Output-voltage clamp	$C_{OUT} = 1\mu\text{F}$, $R_L = 100\Omega$, $V_{IN} = 6.5\text{V}$		5.65	5.8	6	V
CURRENT LIMIT							
I_{LIM}	Current limit	$V_{IN} = 5\text{V}$, $R_{LIM} = 16.6\text{k}\Omega$, $T_A = 25^\circ\text{C}$		1.35	1.5	1.65	A
		$V_{IN} = 5\text{V}$, $R_{LIM} = 25\text{k}\Omega$, $T_A = 25^\circ\text{C}$		0.9	1	1.1	A
		$V_{IN} = 5\text{V}$, $R_{LIM} = 50\text{k}\Omega$, $T_A = 25^\circ\text{C}$		0.45	0.5	0.55	A
t_{DEG_OCP}	OCP deglitch time		8		ms		
t_{OCP_RETRY}	OCP retry delay		16		ms		
POWER MOSFET							
R_{dson}	Switch on resistance	$I_{OUT} = 0.2\text{A}$		90	105	120	m Ω
		$I_{OUT} = 0.45\text{A}$		90	105	120	m Ω
THERMAL							
T_{SDN}	Thermal shutdown threshold	Temperature rising		150		$^\circ\text{C}$	

Typical Characteristics

Ambient temperature is 25°C, $V_{IN} = 5V$, $C_{IN} = C_{OUT} = 1\mu F$, $R_{ILIM} = 25k\Omega$, unless otherwise noted .

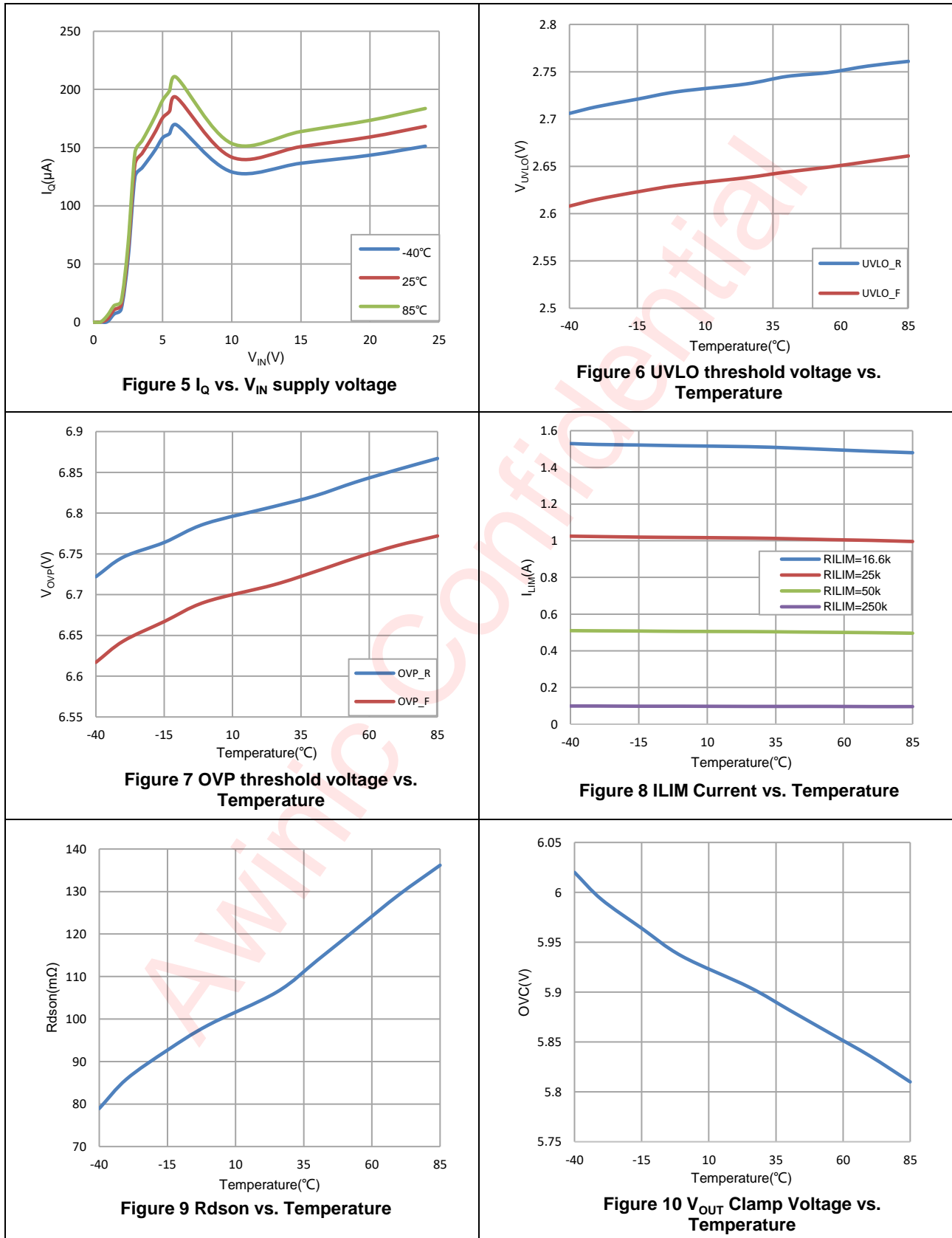

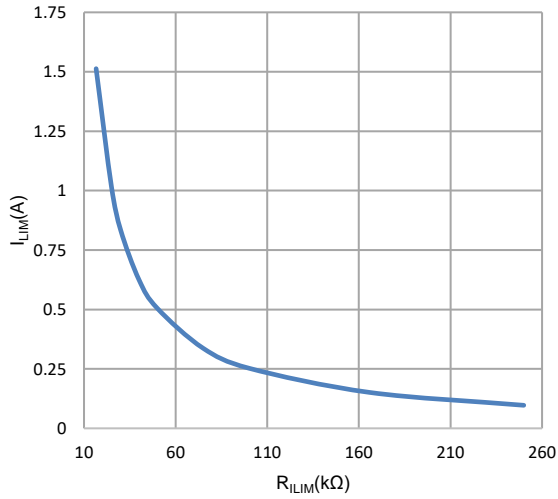

Figure 11 Current Limit vs. R_ILIM

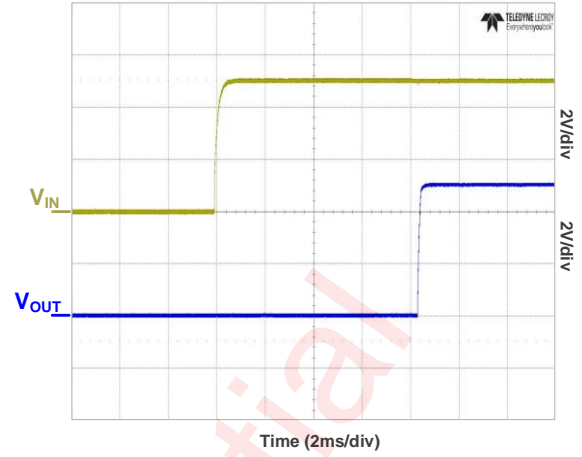

Figure 12 V_IN Turn-On Delay: Input↑ to Output Ramp↑

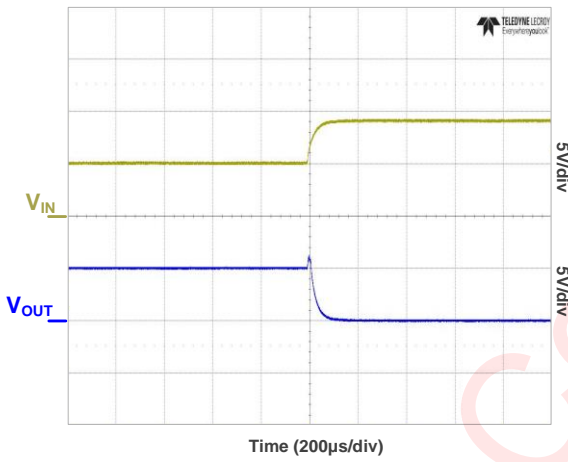

Figure 13 Over-voltage Protection Response

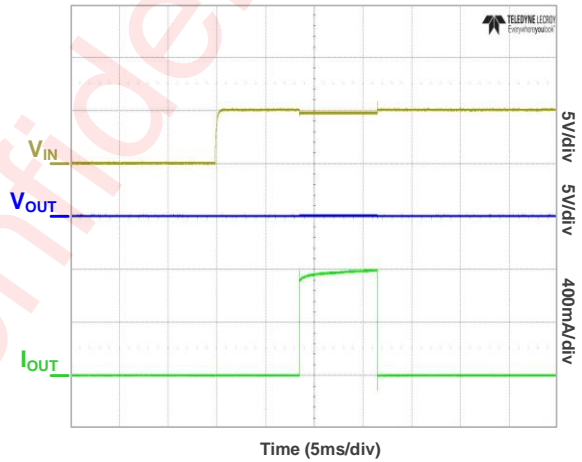

Figure 14 V_OUT Short starting

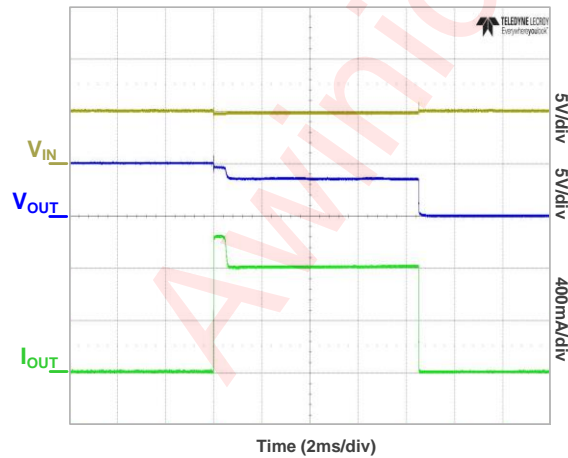

Figure 15 Over-current Protection (2ms)

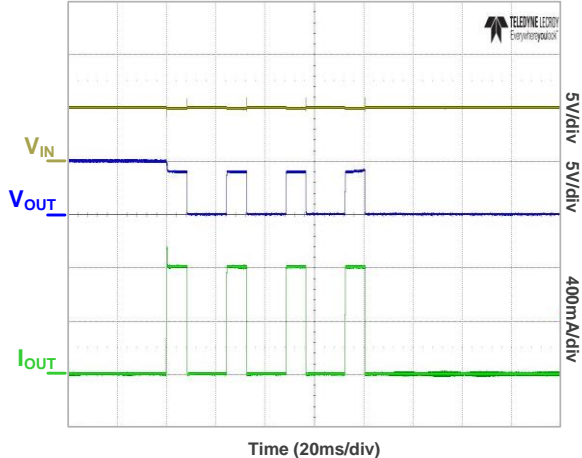

Figure 16 Over-current Protection (20ms)

Detailed Functional Description

AWP35021 is a smart e-Fuse with robust over-current and over-voltage protection. It provides robust protection for all systems and applications powered from 3V to 6.8V. V_{IN} can withstand up to 32V.

The device allows the user to program the over current limit threshold between 0.1A and 1.5A via an external resistor by the ILIM pin. If the current value of the system exceeds a certain range, the device limits the input current value to a safe range for a period of time and then turns off the MOSFET. The device also monitors its internal temperature and turns off the internal MOSFETs when it exceeds 150°C. The device allows the processor to control its operating state and provide information about the fault state to the host.

Over-voltage protection

The device has internal over-voltage protection, and its threshold voltage is 6.8V. When over voltage event happens, power switch is turned off to protect downstream load.

Over-load and short-circuit protection

Load current is monitored by sensing voltage across an internal sense resistor. Current limit threshold is programmed by connecting external resistor R_{ILIM} to GND.

$$I_{LIM_typ}(A) = \frac{25}{R_{ILIM}}$$

Where R_{ILIM} is in k Ω . When over load happens, current is limited to the current limit threshold and persists the t_{DEG_OCP} time, where t_{DEG_OCP} is the over-current protection deglitch time. If the over-current duration is less than the t_{DEG_OCP} , the device continues to work. If the over-current duration is greater than the t_{DEG_OCP} , the device turns off the internal MOSFETs. After passing through the t_{OCP_RETRY} , the device turns on the MOSFETs and monitors the load current again. After four consecutive OCP events occur, the MOSFETs of the device will be permanently turned off and will no longer be turned on. The MOSFETs can only be turned on by restarting the input power supply.

Output-voltage clamp (OVC)

When the $V_{IN} < 5.8V$, the output voltage changes with the input voltage, and when $5.8V < V_{IN} < 6.8V$, the output-voltage clamp (OVC) circuit clamps the output voltage to 5.8V. When the V_{IN} is in the range of 0 to 32V, it can be divided to four modes as shown in Figure 17.

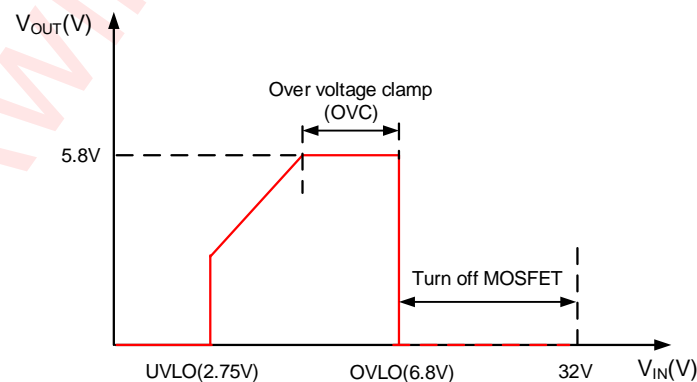

Figure 17 Output vs Input voltage

Thermal Shutdown

The device has a built-in temperature sensor which monitors the internal junction temperature. When the

junction temperature exceeds 150°C, power switch turns off.

PCB Layout Consideration

To obtain the optimal performance of AWP35021, PCB layout should be considered carefully. Here are some guidelines:

1. Place C_{IN} as close as possible to IN.
2. Place C_{OUT} as close as possible to OUT.
3. Place R_{LIM} as close as ILIM.
4. IN, OUT support 1.5A current, the connection lines should be as wide as possible.
5. Connect the IN and OUT pads to a large IN and OUT plane respectively to achieve better thermal performance.

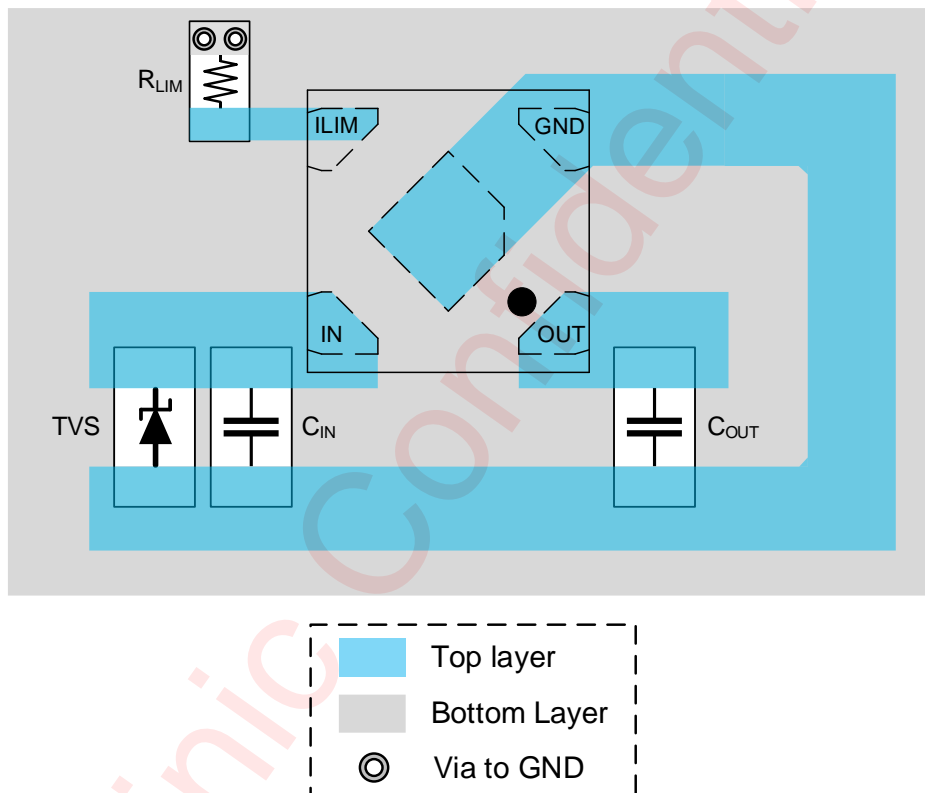
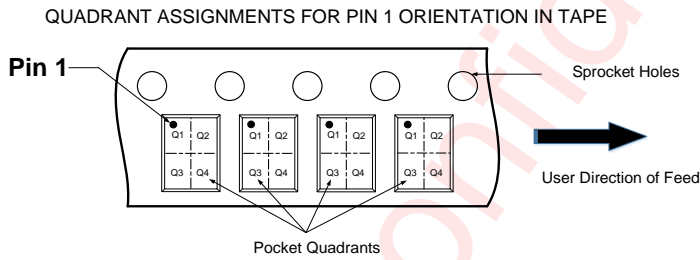
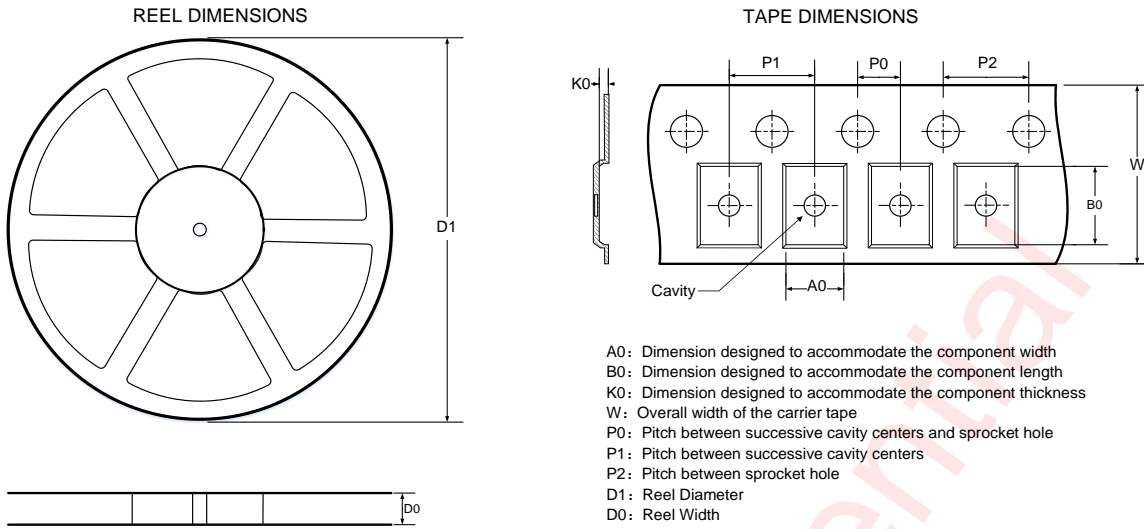

Figure 18 External Components Placements and PCB Layout Example

Tape And Reel Information



Note: The above picture is for reference only. Please refer to the value in the table below for the actual size

DIMENSIONS AND PIN1 ORIENTATION

D1 (mm)	D0 (mm)	A0 (mm)	B0 (mm)	K0 (mm)	P0 (mm)	P1 (mm)	P2 (mm)	W (mm)	Pin1 Quadrant
178	8.4	1.16	1.16	0.50	2	2	4	8	Q1

All dimensions are nominal

Package Description

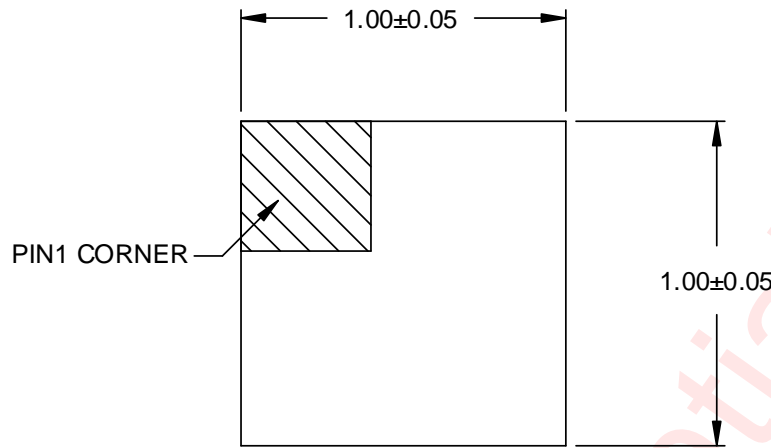

Top View

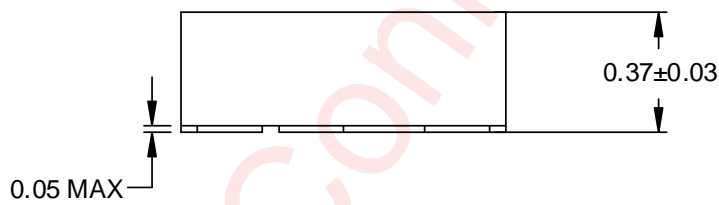

Side View

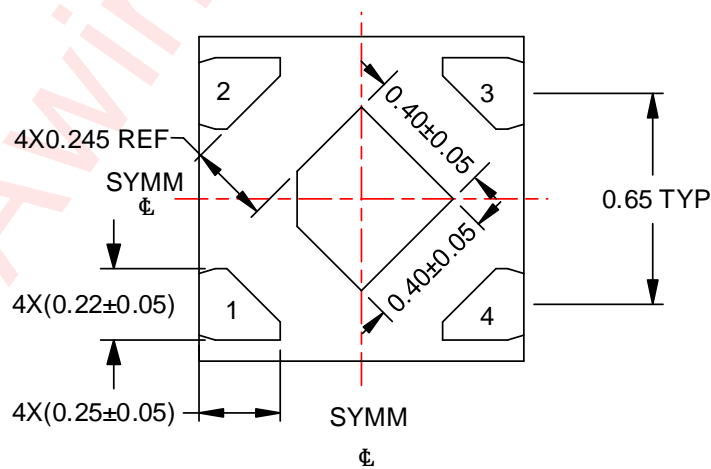

Bottom View

Unit:mm

Land Pattern Data

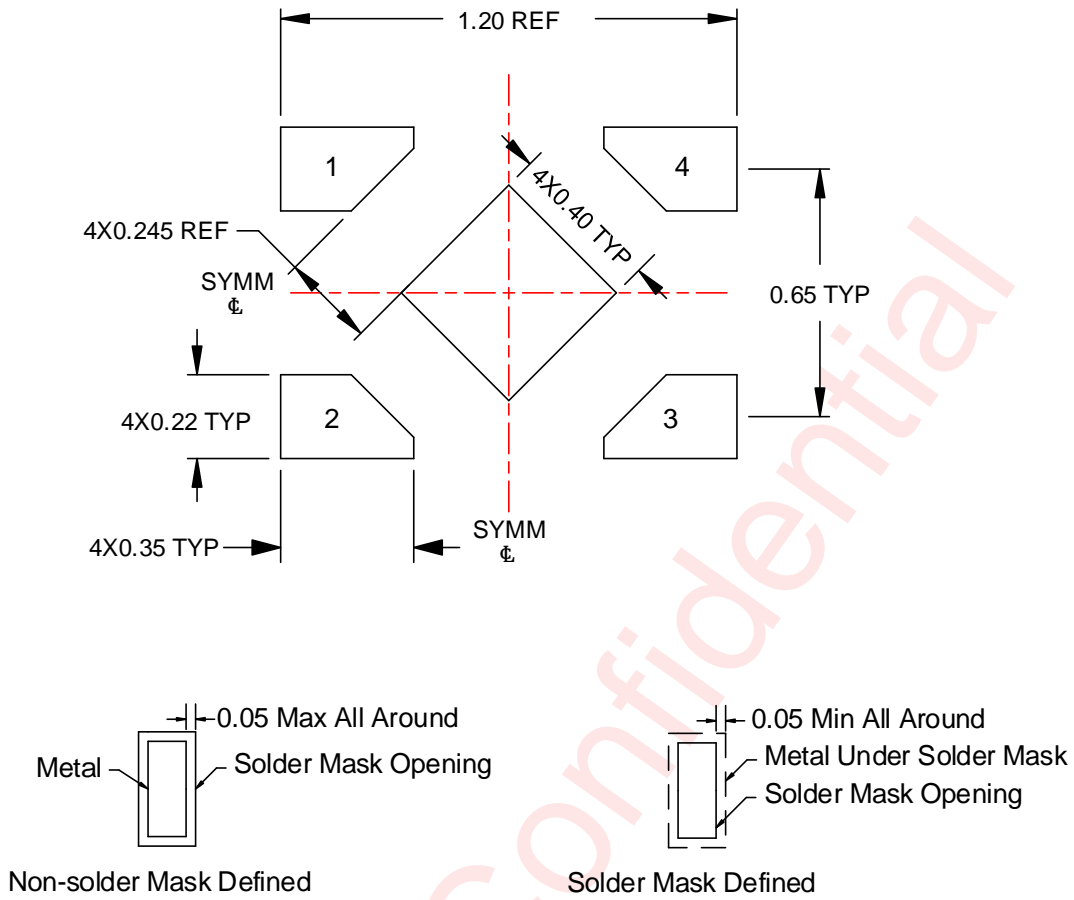

Unit: mm

REVISION HISTORY

Version	Date	Change Record
V1.0	Dec. 2025	Officially released

Awinic Confidential

Disclaimer

All trademarks are the property of their respective owners. Information in this document is believed to be accurate and reliable. However, Shanghai AWINIC Technology Co., Ltd (AWINIC Technology) does not give any representations or warranties, expressed or implied, as to the accuracy or completeness of such information and shall have no liability for the consequences of use of such information.

AWINIC Technology reserves the right to make changes to information published in this document, including without limitation specifications and product descriptions, at any time and without notice. Customers shall obtain the latest relevant information before placing orders and shall verify that such information is current and complete. This document supersedes and replaces all information supplied prior to the publication hereof.

AWINIC Technology products are not designed, authorized or warranted to be suitable for use in medical, military, aircraft, space or life support equipment, nor in applications where failure or malfunction of an AWINIC Technology product can reasonably be expected to result in personal injury, death or severe property or environmental damage. AWINIC Technology accepts no liability for inclusion and/or use of AWINIC Technology products in such equipment or applications and therefore such inclusion and/or use is at the customer's own risk.

Applications that are described herein for any of these products are for illustrative purposes only. AWINIC Technology makes no representation or warranty that such applications will be suitable for the specified use without further testing or modification.

All products are sold subject to the general terms and conditions of commercial sale supplied at the time of order acknowledgement.

Nothing in this document may be interpreted or construed as an offer to sell products that is open for acceptance or the grant, conveyance or implication of any license under any copyrights, patents or other industrial or intellectual property rights.

Reproduction of AWINIC information in AWINIC data books or data sheets is permissible only if reproduction is without alteration and is accompanied by all associated warranties, conditions, limitations, and notices. AWINIC is not responsible or liable for such altered documentation. Information of third parties may be subject to additional restrictions.

Resale of AWINIC components or services with statements different from or beyond the parameters stated by AWINIC for that component or service voids all express and any implied warranties for the associated AWINIC component or service and is an unfair and deceptive business practice. AWINIC is not responsible or liable for any such statements.