

Features

- High Speed CMOS Technology
- Complementary Outputs
- Positive Voltage Control
- Low Power Dissipation
- Plastic SOIC Package for SMT Applications
- Tape and Reel Packaging Available
- Lead-Free SOIC-8 Package
- 100% Matte Tin Plating over Copper
- Halogen-Free “Green” Mold Compound
- 260°C Reflow Compatible
- RoHS* Compliant Version of DR65-0109

Description

M/A-COM's MADRCC0005 is a Single channel driver used to translate TTL control inputs into complementary gate voltages for GaAs FET microwave switches and attenuators. High speed analog CMOS technology is utilized to achieve low power dissipation at moderate to high speeds, encompassing most microwave switching applications.

Ordering Information

Part Number	Package
MADRCC0005	Bulk Packaging
MADRCC0005TR	1000 piece reel

Note: Reference Application Note M513 for reel size information.

Guaranteed Operating Ranges

Symbol	Parameter ¹	Unit	Min	Typical	Max
V _{CC}	Positive DC Supply Voltage	V	4.5	5.0	5.5
V _{EE}	Negative DC Supply Voltage	V	-5.5	-5.0	-4.5
V _{CC-V_{EE}}	Positive to Negative Supply Range	V	9.0	10.0	11.0
T _A	Operating Ambient Temperature	°C	-40	+25	+85
I _{OH}	DC Output Current - HIGH	mA	—	—	-1.0
I _{OL}	DC Output Current - LOW	mA	—	—	1.0
T _{rise} , T _{fall}	Maximum Input Rise or Fall Time	nS	—	—	500

1. All voltages are relative to GND

* Restrictions on Hazardous Substances, European Union Directive 2002/95/EC.

M/A-COM Technology Solutions Inc. (MACOM) and its affiliates reserve the right to make changes to the product(s) or information contained herein without notice. Visit www.macom.com for additional data sheets and product information.

Logic Diagram

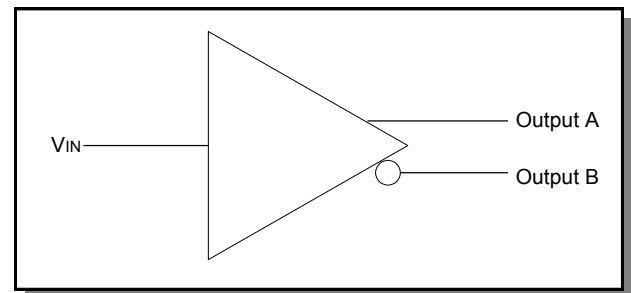

Pin Configuration

Pin No.	Function
1	V _{CC}
2	V _{IN}
3	GND
4	GND
5	GND
6	Output A
7	Output B
8	V _{EE}

AC & DC Characteristics Over Guaranteed Operating Range

Symbol	Parameter	Test Conditions		Units	Min	Typ	Max
V_{IH}	Input HIGH Voltage	Guaranteed HIGH Input Voltage		V	2.0	—	-
V_{IL}	Input LOW Voltage	Guaranteed LOW Input Voltage		V	-	—	0.8
V_{OH}	Output HIGH Voltage	$I_{OH} = -1 \text{ mA}$	$V_{EE} = \text{Max}$	V	-0.1	—	-
V_{OL}	Output LOW Voltage	$I_{OL} = 1 \text{ mA}$	$V_{EE} = \text{Max}$	V	—	—	$V_{EE} + 0.1$
I_{IN}	Input Leakage Current	$V_{IN} = V_{CC}$ or GND	$V_{EE} = \text{Min}$	μA	-1.0	0	1.0
I_{CC}	Quiescent Supply Current	$V_{CC} = \text{Max}$	$V_{EE} = \text{Min}$ $V_{IN} = V_{CC}$ or GND	μA	—	—	400
T_{PHL}, T_{PLH}	Propagation Delay	Guaranteed -40°C to $+85^\circ \text{C}$		nS	—	—	50
T_{THL}, T_{TLH}	Output Transition Time	Guaranteed -40°C to $+85^\circ \text{C}$		nS	—	—	25
	Delay Skew, Output A to Output B	Guaranteed -40°C to $+85^\circ \text{C}$		nS	—	—	8

See Switching Wave Forms for the definition of the switching terms.
Supplies must be by-passed with .01 μF Capacitors.

Switching Waveforms

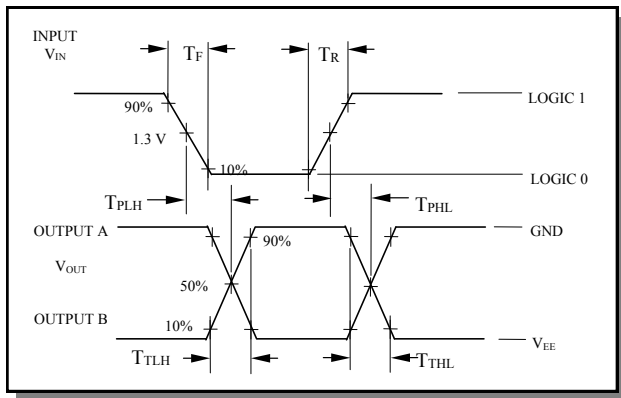

Absolute Maximum Ratings^{2,3}

Parameter	Absolute Maximum
V_{CC}	- .5V to + 6.0 V
V_{EE}	- 6.0 V to - .5 V
$V_{CC} - V_{EE}$	12 V
V_{IN}^4	$V_{CC} + .5 \text{ V}$
V_{OUT}	$V_{EE} - .5 \text{ V}$
Storage Temperature	-65°C to $+150^\circ \text{C}$

- Exceeding any one or combination of these limits may cause permanent damage to this device.
- M/A-COM does not recommend sustained operation near these survivability limits.
- Standard CMOS TTL interface, latch-up will occur if logic signal is applied prior to power supply.

Handling Procedures

Please observe the following precautions to avoid damage:

Static Sensitivity

Silicon Integrated Circuits are sensitive to electrostatic discharge (ESD) and can be damaged by static electricity. Proper ESD control techniques should be used when handling these devices.

Truth Table

Input	Outputs	
V_{IN}	A	B
0	V_{EE}	GND
1	GND	V_{EE}

Lead-Free, SOIC-8[†]

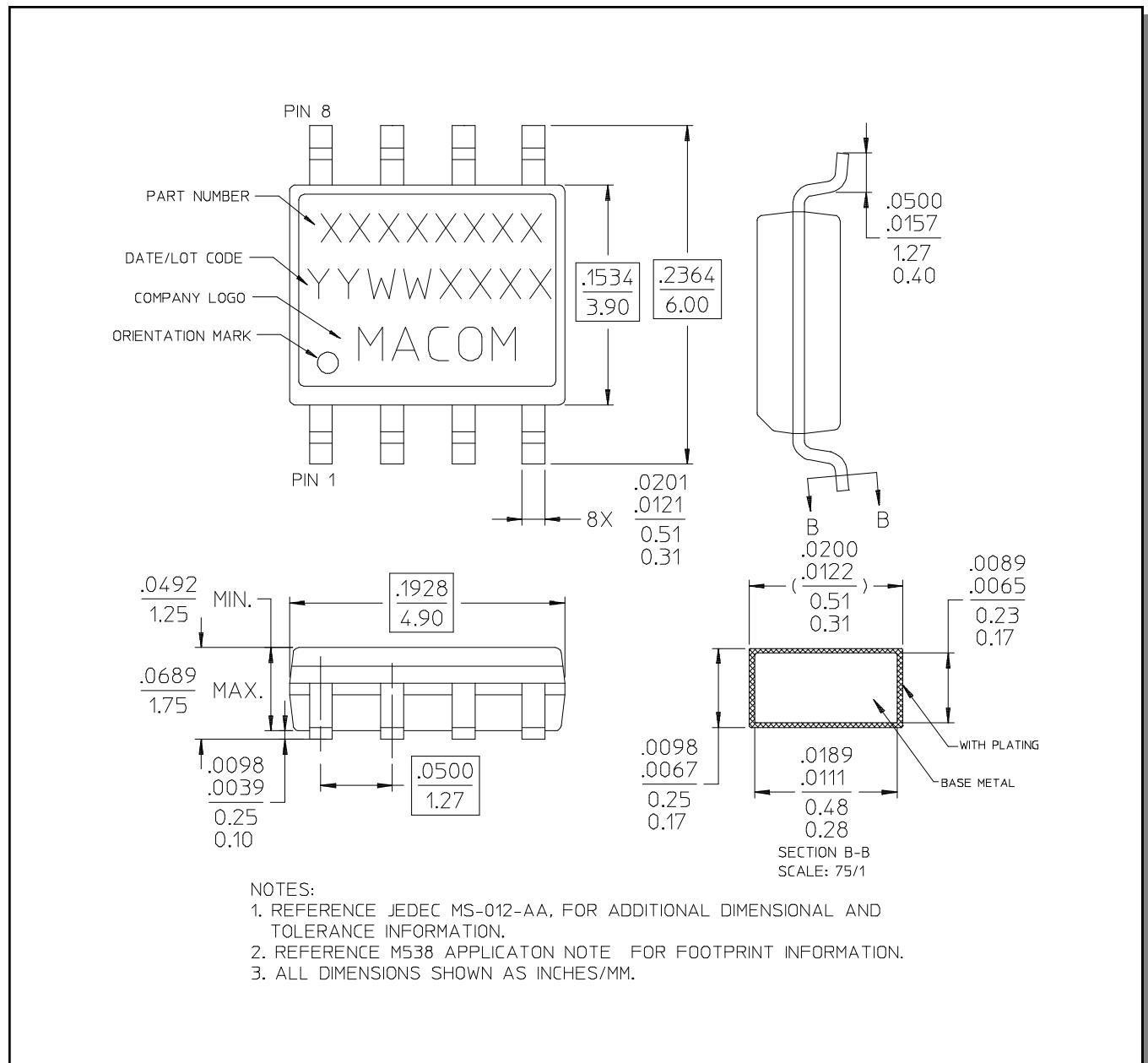

[†] Reference Application Note M538 for lead-free solder reflow recommendations.

M/A-COM Technology Solutions Inc. All rights reserved.

Information in this document is provided in connection with M/A-COM Technology Solutions Inc ("MACOM") products. These materials are provided by MACOM as a service to its customers and may be used for informational purposes only. Except as provided in MACOM's Terms and Conditions of Sale for such products or in any separate agreement related to this document, MACOM assumes no liability whatsoever. MACOM assumes no responsibility for errors or omissions in these materials. MACOM may make changes to specifications and product descriptions at any time, without notice. MACOM makes no commitment to update the information and shall have no responsibility whatsoever for conflicts or incompatibilities arising from future changes to its specifications and product descriptions. No license, express or implied, by estoppel or otherwise, to any intellectual property rights is granted by this document.

THESE MATERIALS ARE PROVIDED "AS IS" WITHOUT WARRANTY OF ANY KIND, EITHER EXPRESS OR IMPLIED, RELATING TO SALE AND/OR USE OF MACOM PRODUCTS INCLUDING LIABILITY OR WARRANTIES RELATING TO FITNESS FOR A PARTICULAR PURPOSE, CONSEQUENTIAL OR INCIDENTAL DAMAGES, MERCHANTABILITY, OR INFRINGEMENT OF ANY PATENT, COPYRIGHT OR OTHER INTELLECTUAL PROPERTY RIGHT. MACOM FURTHER DOES NOT WARRANT THE ACCURACY OR COMPLETENESS OF THE INFORMATION, TEXT, GRAPHICS OR OTHER ITEMS CONTAINED WITHIN THESE MATERIALS. MACOM SHALL NOT BE LIABLE FOR ANY SPECIAL, INDIRECT, INCIDENTAL, OR CONSEQUENTIAL DAMAGES, INCLUDING WITHOUT LIMITATION, LOST REVENUES OR LOST PROFITS, WHICH MAY RESULT FROM THE USE OF THESE MATERIALS.

MACOM products are not intended for use in medical, lifesaving or life sustaining applications. MACOM customers using or selling MACOM products for use in such applications do so at their own risk and agree to fully indemnify MACOM for any damages resulting from such improper use or sale.

Mouser Electronics

Authorized Distributor

Click to View Pricing, Inventory, Delivery & Lifecycle Information:

[MACOM:](#)

[MADRCC0006TR](#) [MADRCC0005](#)