

# TP-104 Series Color Coded Printed Circuit Test Points

Color Coded Printed Circuit Test Points



## Specifications

### Materials:

**Contact Material:** .015" x .030" Phosphor Bronze #510 Alloy

**Finish:** .0001 Matte Tin over .00005 Nickel

**Collar:** 15% Glass Filled Polyester

### Electrical:

**Mounting Holes:** .063" diameter hole

### Special Notations:

The specifically designed hand tool, part number 1040, speeds cutting, gripping and insertion of TP-104 test points.

## TP-104 Contacts

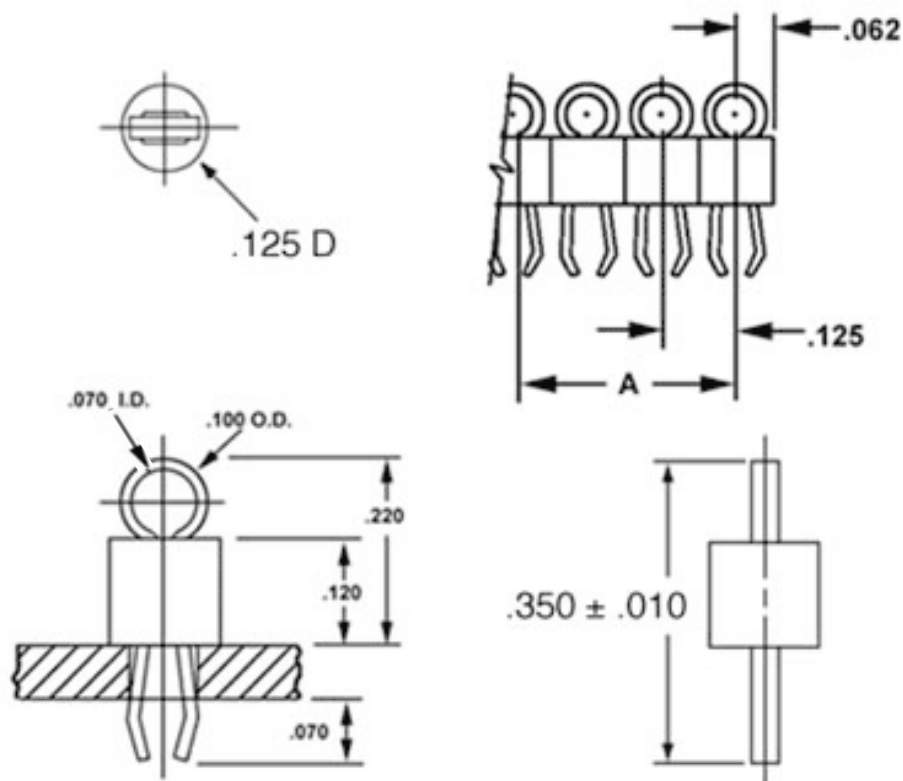

## TP-104 Dimension Chart

Part Number	Dimension A	Part Number	Dimension A
TP-104-01	NA	TP-104-16	1.875
TP-104-02	.125	TP-104-17	2.000
TP-104-03	.250	TP-104-18	2.125
TP-104-04	.375	TP-104-19	2.250
TP-104-05	.500	TP-104-20	2.375
TP-104-06	.625	TP-104-21	2.500
TP-104-07	.750	TP-104-22	2.625
TP-104-08	.875	TP-104-23	2.750
TP-104-09	1.000	TP-104-24	2.875
TP-104-10	1.125	TP-104-25	3.000
TP-104-11	1.250	TP-104-26	3.125
TP-104-12	1.375	TP-104-27	3.250
TP-104-13	1.500	TP-104-28	3.375
TP-104-14	1.625	TP-104-29	3.500
TP-104-15	1.750	TP-104-30	3.625

## Ordering Information

### Example:

**TP-104 - 30 - 01**

● **Series Designation:**  
TP-104

● **Number of Positions:**  
1 through 30

● **Color:**

00 = Black	05 = Green
01 = Brown	06 = Blue
02 = Red	07 = <small>Purple</small> (Discontinued)
03 = Orange	08 = Gray
04 = Yellow	09 = White

## Product Description

The new TP-104 Series takes Components Corporation's highly-efficient and economical loop configured test point design one step further, by adding a plastic standoff that boosts visibility and allows for easy polarization and identification. The TP-104 incorporates all of the design features of all Component's test points - solid non-slip grip of test clips and probes, low profile, single hole wave-solderable mounting, and the elimination of skin punctures suffered by users of wrap posts as substitute test points.

The TP-104 is furnished in 30-position breakaway strips with 0.125" centers that make storage, handling and even tandem installations a snap. Component's special hand tool #1040 further enhances board mounting with test point separating, gripping and positioning functions accomplished in one easy motion. Standard TP-104 colors are red and black, with special colors available on order.

The TP-104 can be ordered pre-cut to any number of positions up to 30. Individual and tandem units hold securely when inserted in .062" diameter holes for soldering operation. The rectangular passage in the TP-104's molded standoff maintains wire form alignment, important in tandem installations.

# **Certificate of Compliance with Directive 2015/863/EU RoHS and EU Regulations EC 1907/2006**

Certificate of Compliance with Directive 2015/863/EU RoHS and EU Regulations EC 1907/2006 This is to certify that Components Corporation designs, manufactures and supplies products to our customers that are in compliance with Directive 2015/863/EU RoHS and EU Regulation EC 1907/2006, 84 SVH. This also pertains to procurement of raw material, component parts and processes.