

## CDCLVP1216 16-LVPECL Output, High-Performance Clock Buffer

### 1 Features

- 2:16 Differential Buffer
- Selectable Clock Inputs Through Control Pin
- Universal Inputs Accept LVPECL, LVDS, and LVCMOS/LVTTL
- 16 LVPECL Outputs
- Maximum Clock Frequency: 2 GHz
- Maximum Core Current Consumption: 110 mA
- Very Low Additive Jitter: <100 fs, RMS in 10-kHz to 20-MHz Offset Range:
  - 57 fs, RMS (Typical) at 122.88 MHz
  - 48 fs, RMS (Typical) at 156.25 MHz
  - 30 fs, RMS (Typical) at 312.5 MHz
- 2.375-V to 3.6-V Device Power Supply
- Maximum Propagation Delay: 550 ps
- Maximum Output Skew: 30 ps
- LVPECL Reference Voltage,  $V_{AC\_REF}$ , Available for Capacitive-Coupled Inputs
- Industrial Temperature Range:  $-40^{\circ}\text{C}$  to  $+85^{\circ}\text{C}$
- Supports  $105^{\circ}\text{C}$  PCB Temperature (Measured with a Thermal Pad)
- ESD Protection Exceeds 2000 V (HBM)
- Available in 7-mm x 7-mm VQFN-48 (RGZ) Package

### 2 Applications

- Wireless Communications
- Telecommunications/Networking
- Medical Imaging
- Test and Measurement Equipment

### 3 Description

The CDCLVP1216 is a highly versatile, low additive jitter buffer that can generate 16 copies of LVPECL clock outputs from one of two selectable LVPECL, LVDS, or LVCMOS inputs for a variety of communication applications. It has a maximum clock frequency up to 2 GHz. The CDCLVP1216 features an on-chip multiplexer (MUX) for selecting one of two inputs that can be easily configured solely through a control pin. The overall additive jitter performance is less than 0.1 ps, RMS from 10 kHz to 20 MHz, and overall output skew is as low as 30 ps, making the device a perfect choice for use in demanding applications.

The CDCLVP1216 clock buffer distributes one of two selectable clock inputs (IN0, IN1) to 16 pairs of differential LVPECL clock outputs (OUT0, OUT15) with minimum skew for clock distribution. The CDCLVP1216 can accept two clock sources into an input multiplexer. The inputs can be LVPECL, LVDS, or LVCMOS/LVTTL.

The CDCLVP1216 is specifically designed for driving  $50\text{-}\Omega$  transmission lines. When driving the inputs in single-ended mode, the LVPECL bias voltage ( $V_{AC\_REF}$ ) should be applied to the unused negative input pin. However, for high-speed performance up to 2 GHz, differential mode is strongly recommended.

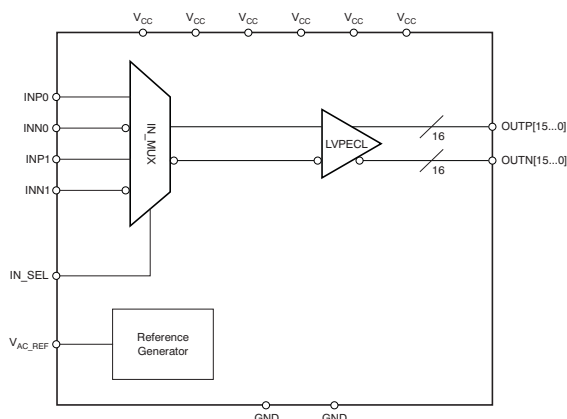
The CDCLVP1216 is packaged in a small 48-pin, 7-mm x 7-mm VQFN package and is characterized for operation from  $-40^{\circ}\text{C}$  to  $+85^{\circ}\text{C}$ .

#### Device Information<sup>(1)</sup>

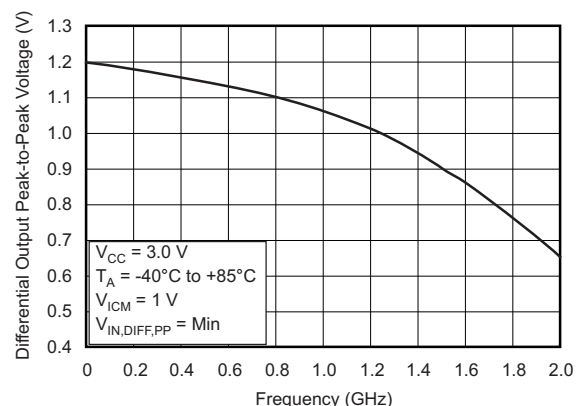
ORDER NUMBER	PACKAGE	BODY SIZE (NOM)
CDCLVP1216	VQFN (48)	7.00 mm x 7.00 mm

(1) For all available packages, see the orderable addendum at the end of the datasheet.

Functional Block Diagram



Differential Output Peak-to-Peak Voltage vs Frequency



## Table of Contents

<b>1 Features</b> .....	<b>1</b>	<b>8 Detailed Description</b> .....	<b>15</b>
<b>2 Applications</b> .....	<b>1</b>	8.1 Overview .....	15
<b>3 Description</b> .....	<b>1</b>	8.2 Functional Block Diagram .....	15
<b>4 Revision History</b> .....	<b>2</b>	8.3 Feature Description .....	15
<b>5 Pin Configuration and Functions</b> .....	<b>4</b>	8.4 Device Functional Modes .....	16
<b>6 Specifications</b> .....	<b>6</b>	<b>9 Applications and Implementation</b> .....	<b>20</b>
6.1 Absolute Maximum Ratings .....	6	9.1 Application Information .....	20
6.2 ESD Ratings .....	6	9.2 Typical Application .....	20
6.3 Recommended Operating Conditions .....	6	<b>10 Power Supply Recommendations</b> .....	<b>22</b>
6.4 Thermal Information .....	6	<b>11 Layout</b> .....	<b>23</b>
6.5 Electrical Characteristics: LVCMOS Input .....	7	11.1 Layout Guidelines .....	23
6.6 Electrical Characteristics: Differential Input .....	7	11.2 Layout Example .....	23
6.7 Electrical Characteristics: LVPECL Output, at $V_{CC} = 2.375\text{ V to }2.625\text{ V}$ .....	7	11.3 Thermal Considerations .....	23
6.8 Electrical Characteristics: LVPECL Output, at $V_{CC} = 3\text{ V to }3.6\text{ V}$ .....	8	<b>12 Device and Documentation Support</b> .....	<b>24</b>
6.9 Timing Requirements, at $V_{CC} = 2.375\text{ V to }2.625\text{ V}$ ..	8	12.1 Documentation Support .....	24
6.10 Timing Requirements, at $V_{CC} = 3\text{ V to }3.6\text{ V}$ .....	10	12.2 Community Resources .....	24
6.11 Pin Characteristics .....	10	12.3 Trademarks .....	24
6.12 Typical Characteristics .....	12	12.4 Electrostatic Discharge Caution .....	24
<b>7 Parameter Measurement Information</b> .....	<b>12</b>	12.5 Glossary .....	24
7.1 Test Configurations .....	12	<b>13 Mechanical, Packaging, and Orderable Information</b> .....	<b>24</b>

## 4 Revision History

NOTE: Page numbers for previous revisions may differ from page numbers in the current version.

Changes from Revision E (September 2014) to Revision F	Page
• Changed <i>Handling Ratings</i> to <i>ESD Ratings</i> ; moved $T_{stg}$ to <i>Absolute Maximum Ratings</i> .....	6
• Added PCB temperature in <i>Recommended Operating Conditions</i> .....	6
• Added $V_{OH}$ specification for $T_{PCB} \leq 105^{\circ}\text{C}$ in <i>Electrical Characteristics: LVPECL Output, at <math>V_{CC} = 2.375\text{ V to }2.625\text{ V}</math></i> .....	7
• Added $V_{OL}$ specification for $T_{PCB} \leq 105^{\circ}\text{C}$ in <i>Electrical Characteristics: LVPECL Output, at <math>V_{CC} = 2.375\text{ V to }2.625\text{ V}</math></i> .....	7
• Added $V_{OH}$ specification for $T_{PCB} \leq 105^{\circ}\text{C}$ in <i>Electrical Characteristics: LVPECL Output, at <math>V_{CC} = 3\text{ V to }3.6\text{ V}</math></i> .....	8
• Added $V_{OH}$ specification for $T_{PCB} \leq 105^{\circ}\text{C}$ in <i>Electrical Characteristics: LVPECL Output, at <math>V_{CC} = 3\text{ V to }3.6\text{ V}</math></i> .....	8
• Added $I_{EE}$ specification for $T_{PCB} \leq 105^{\circ}\text{C}$ in <i>Electrical Characteristics: LVPECL Output, at <math>V_{CC} = 3\text{ V to }3.6\text{ V}</math></i> .....	8
• Added $I_{CC}$ specification for $T_{PCB} \leq 105^{\circ}\text{C}$ in <i>Electrical Characteristics: LVPECL Output, at <math>V_{CC} = 3\text{ V to }3.6\text{ V}</math></i> .....	8
• Added $I_{EE}$ specification for $T_{PCB} \leq 105^{\circ}\text{C}$ in <i>Electrical Characteristics: LVPECL Output, at <math>V_{CC} = 2.375\text{ V to }2.625\text{ V}</math></i> .....	9
• Added $I_{CC}$ specification for $T_{PCB} \leq 105^{\circ}\text{C}$ in <i>Electrical Characteristics: LVPECL Output, at <math>V_{CC} = 2.375\text{ V to }2.625\text{ V}</math></i> .....	9
• Added <i>Thermal Considerations</i> section .....	23
• Added <i>Community Resources</i> .....	24

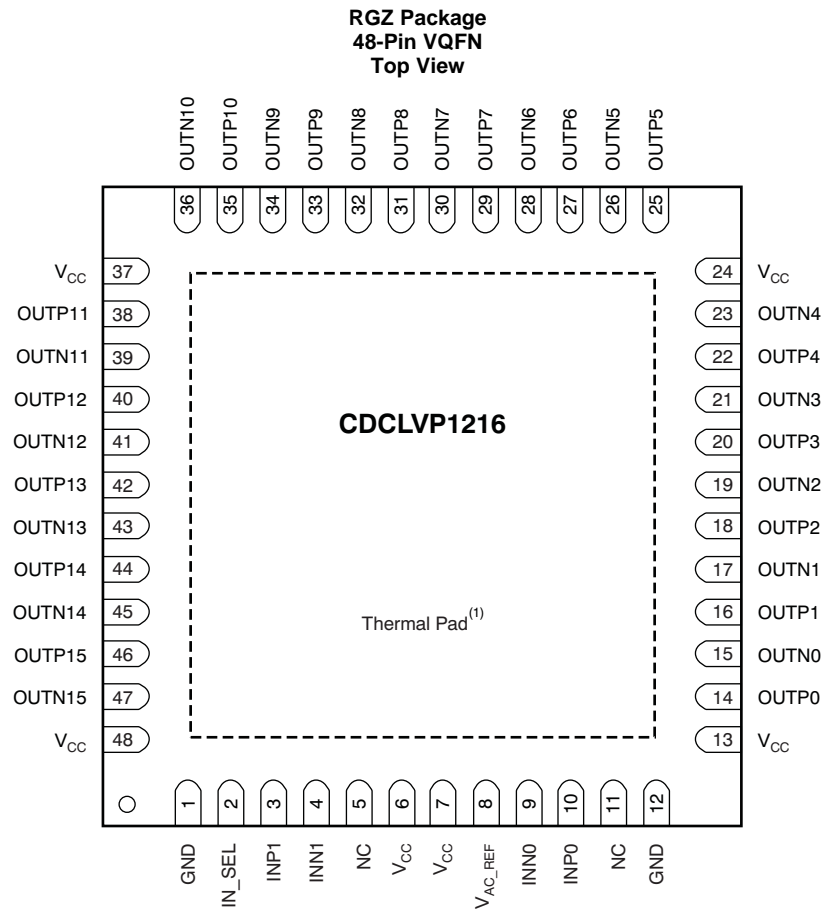
Changes from Revision D (June 2014) to Revision E	Page
• Added titles to first page images .....	1
• Added note at the beginning of <i>Applications and Implementation</i> .....	20
• Changed JEDEC symbol to $R_{\theta JA}$ .....	23

<b>Changes from Revision C (August 2011) to Revision D</b>	<b>Page</b>
• Added data sheet flow and layout to conform with new TI standards. Added the following sections: <i>Application and Implementation; Power Supply Recommendations; Layout, Device and Documentation Support, Mechanical, Packaging, and Ordering Information</i> .....	1
• Added $f_{IN} = 125\text{ MHz}, 312.5\text{ MHz}$ for $V_{OUT, DIFF, PP}$ .....	7
• Typical values, Max values, and footnotes for 122.88 MHz, 156.25 MHz, and 312.5 MHz test conditions corresponding to Random Additive Jitter for <i>Electrical Characteristics: LVPECL Output, at <math>V_{CC} = 2.375\text{ V}</math> to <math>2.625\text{ V}</math></i> .....	9
• Typical values, Max values, and footnotes for 122.88 MHz, 156.25 MHz, and 312.5 MHz test conditions corresponding to Random Additive Jitter for <i>Electrical Characteristics: LVPECL Output, at <math>V_{CC} = 3\text{ V}</math> to <math>3.6\text{ V}</math></i> .....	10

<b>Changes from Revision B (May 2010) to Revision C</b>	<b>Page</b>
• Revised description of pin 8 in <i>Pin Functions</i> .....	5
• Corrected $V_{IL}$ parameter description in <i>Electrical Characteristics</i> table for LVCMOS input .....	7
• Added footnote <i>Internally generated bias voltage ...</i> to <i>Electrical Characteristics: LVPECL Output, at <math>V_{CC} = 2.375\text{ V}</math> to <math>2.625\text{ V}</math></i> .....	7
• Changed recommended resistor values in <a href="#">Figure 12</a> .....	16
• Changed recommended resistor values in <a href="#">Figure 16</a> .....	18

<b>Changes from Revision A (July 2009) to Revision B</b>	<b>Page</b>
• Changed description of INN1, INN0 and INP1, INP0 pins in <i>Pin Functions</i> .....	4
• Changed descriptions of all output pins in <i>Pin Functions</i> .....	5

## 5 Pin Configuration and Functions



(1) Thermal pad must be soldered to ground.

### Pin Functions

PIN		TYPE	DESCRIPTION
NAME	NUMBER		
GND	1, 12	Ground	Device grounds
IN_SEL	2	Input	Pulldown (see <a href="#">Pin Characteristics</a> ) MUX select input for input choice (see <a href="#">Table 1</a> )
INP0, INN0	10, 9	Input	Differential input pair or single-ended input. Unused input pair can be left floating.
INP1, INN1	3, 4	Input	Redundant differential input pair or single-ended input. Unused input pair can be left floating.
NC	5, 11	—	Do not connect
OUTP0, OUTN0	14, 15	Output	Differential LVPECL output pair no. 0. Unused output pair can be left floating.
OUTP1, OUTN1	16, 17	Output	Differential LVPECL output pair no. 1. Unused output pair can be left floating.
OUTP2, OUTN2	18, 19	Output	Differential LVPECL output pair no. 2. Unused output pair can be left floating.
OUTP3, OUTN3	20, 21	Output	Differential LVPECL output pair no. 3. Unused output pair can be left floating.
OUTP4, OUTN4	22, 23	Output	Differential LVPECL output pair no. 4. Unused output pair can be left floating.
OUTP5, OUTN5	25, 26	Output	Differential LVPECL output pair no. 5. Unused output pair can be left floating.
OUTP6, OUTN6	27, 28	Output	Differential LVPECL output pair no. 6. Unused output pair can be left floating.
OUTP7, OUTN7	29, 30	Output	Differential LVPECL output pair no. 7. Unused output pair can be left floating.
OUTP8, OUTN8	31, 32	Output	Differential LVPECL output pair no. 8. Unused output pair can be left floating.
OUTP9, OUTN9	33, 34	Output	Differential LVPECL output pair no. 9. Unused output pair can be left floating.

**Pin Functions (continued)**

PIN		TYPE	DESCRIPTION
NAME	NUMBER		
OUTP10, OUTN10	35, 36	Output	Differential LVPECL output pair no. 10. Unused output pair can be left floating.
OUTP11, OUTN11	38, 39	Output	Differential LVPECL output pair no. 11. Unused output pair can be left floating.
OUTP12, OUTN12	40, 41	Output	Differential LVPECL output pair no. 12. Unused output pair can be left floating.
OUTP13, OUTN13	42, 43	Output	Differential LVPECL output pair no. 13. Unused output pair can be left floating.
OUTP14, OUTN14	44, 45	Output	Differential LVPECL output pair no. 14. Unused output pair can be left floating.
OUTP15, OUTN15	46, 47	Output	Differential LVPECL output pair no. 15. Unused output pair can be left floating.
V <sub>AC_REF</sub>	8	Output	Bias voltage output for capacitive coupled inputs. Do not use V <sub>AC_REF</sub> at V <sub>CC</sub> < 3 V. If used, it is recommended to use a 0.1-μF capacitor to GND on this pin. The output current is limited to 2 mA.
V <sub>CC</sub>	6, 7, 13, 24, 37, 48	Power	2.5 or 3.3-V supplies for the device

## 6 Specifications

### 6.1 Absolute Maximum Ratings

 over operating free-air temperature range (unless otherwise noted)<sup>(1)</sup>

		MIN	MAX	UNIT
V <sub>CC</sub>	Supply voltage <sup>(2)</sup>	-0.5	4.6	V
V <sub>IN</sub>	Input voltage <sup>(3)</sup>	-0.5	V <sub>CC</sub> + 0.5	V
V <sub>OUT</sub>	Output voltage <sup>(3)</sup>	-0.5	V <sub>CC</sub> + 0.5	V
I <sub>IN</sub>	Input current		20	mA
I <sub>OUT</sub>	Output current		50	mA
T <sub>A</sub>	Specified free-air temperature (no airflow)	-40	85	°C
T <sub>J</sub>	Maximum junction temperature		125	°C
T <sub>stg</sub>	Storage temperature	-65	150	°C

- (1) Stresses beyond those listed under *Absolute Maximum Ratings* may cause permanent damage to the device. These are stress ratings only, which do not imply functional operation of the device at these or any other conditions beyond those indicated under *Recommended Operating Conditions*. Exposure to absolute-maximum-rated conditions for extended periods may affect device reliability.
- (2) All supply voltages must be supplied simultaneously.
- (3) The input and output negative voltage ratings may be exceeded if the input and output clamp-current ratings are observed.

### 6.2 ESD Ratings

		VALUE	UNIT
V <sub>(ESD)</sub>	Electrostatic discharge <sup>(1)</sup>	Human body model (HBM), per ANSI/ESDA/JEDEC JS-001, all pins <sup>(2)</sup>	2000 V

- (1) Electrostatic discharge (ESD) to measure device sensitivity and immunity to damage caused by assembly line electrostatic discharges in to the device.
- (2) JEDEC document JEP155 states that 500-V HBM allows safe manufacturing with a standard ESD control process.

### 6.3 Recommended Operating Conditions

over operating free-air temperature range (unless otherwise noted)

PARAMETER		MIN	NOM	MAX	UNIT
V <sub>CC</sub>	Supply voltage	2.375	2.50/3.30	3.60	V
T <sub>A</sub>	Ambient temperature	-40		85	°C
T <sub>PCB</sub>	PCB temperature (measured at thermal pad)			105	°C

### 6.4 Thermal Information

THERMAL METRIC <sup>(1)(2)(3)</sup>		CDCLVP1216		UNIT
		RGZ (VQFN)		
		48 PINS		
R <sub>θJA</sub>	Junction-to-ambient thermal resistance <sup>(4)</sup>	0 LFM	33.8	°C/W
		150 LFM	22.6	
		400 LFM	19.2	
R <sub>θJC(top)</sub>	Junction-to-case (top) thermal resistance		18.2	°C/W
R <sub>θJP</sub>	Thermal resistance, junction-to-pad <sup>(5)</sup>		3.67	°C/W
Ψ <sub>JT</sub>	Junction-to-top characterization parameter		0.5	°C/W
Ψ <sub>JB</sub>	Junction-to-board characterization parameter		8.3	°C/W
R <sub>θJC(bot)</sub>	Junction-to-case (bottom) thermal resistance		3.8	°C/W

- (1) Connected to GND with 16 thermal vias (0.3-mm diameter).
- (2) The package thermal resistance is calculated in accordance with JESD 51 and JEDEC 2S2P (high-K board).
- (3) For more information about traditional and new thermal metrics, see the *Semiconductor and IC Package Thermal Metrics* application report ([SPRA953](#)).
- (4) 4 × 4 vias on pad
- (5) R<sub>θJP</sub> (junction-to-pad) is used for the VQFN package, because the primary heat flow is from the junction to the GND pad of the VQFN package.

## 6.5 Electrical Characteristics: LVCMOS Input

at  $V_{CC} = 2.375\text{ V to }3.6\text{ V}$  and  $T_A = -40^\circ\text{C to }+85^\circ\text{C}$  and  $T_{PCB} \leq 105^\circ\text{C}$  (unless otherwise noted)<sup>(1)</sup>

PARAMETER	TEST CONDITIONS	MIN	TYP	MAX	UNIT
$f_{IN}$	Input frequency			200	MHz
$V_{th}$	Input threshold voltage	External threshold voltage applied to complementary input		1.8	V
$V_{IH}$	Input high voltage	$V_{th} + 0.1$		$V_{CC}$	V
$V_{IL}$	Input low voltage	0		$V_{th} - 0.1$	V
$I_{IH}$	Input high current	$V_{CC} = 3.6\text{ V}, V_{IH} = 3.6\text{ V}$		40	$\mu\text{A}$
$I_{IL}$	Input low current	$V_{CC} = 3.6\text{ V}, V_{IL} = 0\text{ V}$		-40	$\mu\text{A}$
$\Delta V/\Delta T$	Input edge rate	20% to 80%		1.5	V/ns
$I_{CAP}$	Input capacitance		5		pF

(1) Figure 6 and Figure 7 show DC test setup.

## 6.6 Electrical Characteristics: Differential Input

at  $V_{CC} = 2.375\text{ V to }3.6\text{ V}$  and  $T_A = -40^\circ\text{C to }+85^\circ\text{C}$  and  $T_{PCB} \leq 105^\circ\text{C}$  (unless otherwise noted)<sup>(1)</sup>

PARAMETER	TEST CONDITIONS	MIN	TYP	MAX	UNIT
$f_{IN}$	Input frequency	Clock input		2000	MHz
$V_{IN, DIFF, PP}$	Differential input peak-peak voltage	$f_{IN} \leq 1.5\text{ GHz}$		1.5	V
		$1.5\text{ GHz} \leq f_{IN} \leq 2\text{ GHz}$		1.5	V
$V_{ICM}$	Input common-mode level	1		$V_{CC} - 0.3$	V
$I_{IH}$	Input high current	$V_{CC} = 3.6\text{ V}, V_{IH} = 3.6\text{ V}$		40	$\mu\text{A}$
$I_{IL}$	Input low current	$V_{CC} = 3.6\text{ V}, V_{IL} = 0\text{ V}$		-40	$\mu\text{A}$
$\Delta V/\Delta T$	Input edge rate	20% to 80%		1.5	V/ns
$I_{CAP}$	Input capacitance		5		pF

(1) Figure 5 and Figure 8 show DC test setup. Figure 9 shows AC test setup.

## 6.7 Electrical Characteristics: LVPECL Output, at $V_{CC} = 2.375\text{ V to }2.625\text{ V}$

 $T_A = -40^\circ\text{C to }+85^\circ\text{C}$  and  $T_{PCB} \leq 105^\circ\text{C}$  (unless otherwise noted)<sup>(1)</sup>

PARAMETER	TEST CONDITIONS	MIN	TYP	MAX	UNIT
$V_{OH}$	Output high voltage	$T_A \leq 85^\circ\text{C}$		$V_{CC} - 1.26$	$V_{CC} - 0.9$
		$T_{PCB} \leq 105^\circ\text{C}$		$V_{CC} - 1.26$	$V_{CC} - 0.83$
$V_{OL}$	Output low voltage	$T_A \leq 85^\circ\text{C}$		$V_{CC} - 1.7$	$V_{CC} - 1.3$
		$T_{PCB} \leq 105^\circ\text{C}$		$V_{CC} - 1.7$	$V_{CC} - 1.25$
$V_{OUT, DIFF, PP}$	Differential output peak-peak voltage	$f_{IN} \leq 2\text{ GHz}$		0.5	1.35
		$f_{IN} = 125\text{ MHz}, 312.5\text{ MHz}$		1.15	
$V_{AC\_REF}$	Input bias voltage <sup>(2)</sup>	$I_{AC\_REF} = 2\text{ mA}$		$V_{CC} - 1.6$	$V_{CC} - 1.1$
$t_{SK,PP}$	Part-to-part skew			150	ps
$t_{SK,O}$	Output skew			30	ps
$t_{SK,P}$	Pulse skew (with 50% duty cycle input)	Crossing-point-to-crossing-point distortion, $f_{OUT} = 100\text{ MHz}$		-50	50

(1) Figure 10 and Figure 11 show DC and AC test setup.

(2) Internally generated bias voltage ( $V_{AC\_REF}$ ) is for 3.3-V operation only. It is recommended to apply externally generated bias voltage for  $V_{CC} < 3\text{ V}$ .

## 6.8 Electrical Characteristics: LVPECL Output, at $V_{CC} = 3\text{ V to }3.6\text{ V}$

 $T_A = -40^\circ\text{C to }+85^\circ\text{C}$  and  $T_{PCB} \leq 105^\circ\text{C}$  (unless otherwise noted)<sup>(1)</sup>

PARAMETER		TEST CONDITIONS	MIN	TYP	MAX	UNIT
$V_{OH}$	Output high voltage	$T_A \leq 85^\circ\text{C}$	$V_{CC} - 1.26$	$V_{CC} - 0.9$		V
		$T_{PCB} \leq 105^\circ\text{C}$	$V_{CC} - 1.26$	$V_{CC} - 0.85$		
$V_{OL}$	Output low voltage	$T_A \leq 85^\circ\text{C}$	$V_{CC} - 1.7$	$V_{CC} - 1.3$		V
		$T_{PCB} \leq 105^\circ\text{C}$	$V_{CC} - 1.7$	$V_{CC} - 1.3$		
$V_{OUT, DIFF, PP}$	Differential output peak-peak voltage	$f_{IN} \leq 2\text{ GHz}$	0.65		1.35	V
$V_{AC\_REF}$	Input bias voltage	$I_{AC\_REF} = 2\text{ mA}$	$V_{CC} - 1.6$		$V_{CC} - 1.1$	V
$I_{EE}$	Supply internal current	Outputs unterminated, $T_A \leq 85^\circ\text{C}$			110	mA
		$T_{PCB} \leq 105^\circ\text{C}$			112	
$I_{CC}$	Output and internal supply current	All outputs terminated, $50\ \Omega$ to $V_{CC} - 2$ $T_A \leq 85^\circ\text{C}$			618	mA
		$T_{PCB} \leq 105^\circ\text{C}$			675	

(1) [Figure 10](#) and [Figure 11](#) show DC and AC test setup.

## 6.9 Timing Requirements, at $V_{CC} = 2.375\text{ V to }2.625\text{ V}$

 Refer to [Figure 1](#) and [Figure 2](#).

		MIN	NOM	MAX	UNIT
$t_{PD}$	Propagation delay	$V_{IN, DIFF, PP} = 0.1\text{ V}$		550	ps
		$V_{IN, DIFF, PP} = 0.3\text{ V}$		550	
$t_{SK, PP}$	Part-to-part skew			150	ps
$t_{SK, O}$	Output skew			30	ps
$t_{SK, P}$	Pulse skew (with 50% duty cycle input)	Crossing-point-to-crossing-point distortion, $f_{OUT} = 100\text{ MHz}$	-50	50	ps

**Timing Requirements, at  $V_{CC} = 2.375\text{ V}$  to  $2.625\text{ V}$  (continued)**

 Refer to [Figure 1](#) and [Figure 2](#).

		MIN	NOM	MAX	UNIT
$t_{RJIT}$	Random additive jitter (with 50% duty cycle input) <sup>(1)</sup>	$f_{OUT} = 100\text{ MHz}$ , $V_{IN,SE} = V_{CC}$ , $V_{th} = 1.25\text{ V}$ , 10 kHz to 20 MHz	0.11		
		$f_{OUT} = 100\text{ MHz}$ , $V_{IN,SE} = 0.9\text{ V}$ , $V_{th} = 1.1\text{ V}$ , 10 kHz to 20 MHz	0.128		
		$f_{OUT} = 2\text{ GHz}$ , $V_{IN,DIFF,PP} = 0.2\text{ V}$ , $V_{ICM} = 1\text{ V}$ , 10 kHz to 20 MHz	0.053		
		$f_{OUT} = 100\text{ MHz}$ , $V_{IN,DIFF,PP} = 0.15\text{ V}$ , $V_{ICM} = 1\text{ V}$ , 10 kHz to 20 MHz	0.093		
		$f_{OUT} = 100\text{ MHz}$ , $V_{IN,DIFF,PP} = 1\text{ V}$ , $V_{ICM} = 1\text{ V}$ , 10 kHz to 20 MHz	0.092		
		$f_{OUT} = 122.88\text{ MHz}$ , <sup>(2)(3)</sup> Square Wave, $V_{IN-PP} = 1\text{ V}$ , 12 kHz to 20 MHz	0.057	0.088	
		$f_{OUT} = 122.88\text{ MHz}$ , <sup>(2)(3)</sup> Square Wave, $V_{IN-PP} = 1\text{ V}$ , 10 kHz to 20 MHz	0.057	0.088	
		$f_{OUT} = 122.88\text{ MHz}$ , <sup>(2)(3)</sup> Square Wave, $V_{IN-PP} = 1\text{ V}$ , 1 kHz to 40 MHz	0.086	0.121	
		$f_{OUT} = 156.25\text{ MHz}$ , <sup>(3)(4)</sup> Square Wave, $V_{IN-PP} = 1\text{ V}$ , 12 kHz to 20 MHz	0.048	0.071	
		$f_{OUT} = 156.25\text{ MHz}$ , <sup>(3)(4)</sup> Square Wave, $V_{IN-PP} = 1\text{ V}$ , 10 kHz to 20 MHz	0.048	0.071	
		$f_{OUT} = 156.25\text{ MHz}$ , <sup>(3)(4)</sup> Square Wave, $V_{IN-PP} = 1\text{ V}$ , 1 kHz to 40 MHz	0.068	0.097	
		$f_{OUT} = 312.5\text{ MHz}$ , <sup>(3)(5)</sup> Square Wave, $V_{IN-PP} = 1\text{ V}$ , 12 kHz to 20 MHz	0.030	0.048	
$f_{OUT} = 312.5\text{ MHz}$ , <sup>(3)(5)</sup> Square Wave, $V_{IN-PP} = 1\text{ V}$ , 10 kHz to 20 MHz	0.030	0.048			
$f_{OUT} = 312.5\text{ MHz}$ , <sup>(3)(5)</sup> Square Wave, $V_{IN-PP} = 1\text{ V}$ , 1 kHz to 40 MHz	0.045	0.068			
$t_R/t_F$	Output rise/fall time	20% to 80%		200	ps
$I_{EE}$	Supply internal current	Outputs unterminated, $T_A \leq 85^\circ\text{C}$		110	mA
		$T_{PCB} \leq 105^\circ\text{C}$		112	
$I_{EE}$	Output and internal supply current	All outputs terminated, $50\ \Omega$ to $V_{CC} - 2$ $T_A \leq 85^\circ\text{C}$		618	mA
		$T_{PCB} \leq 105^\circ\text{C}$		675	

(1) Parameter is specified by characterization. Not tested in production.

(2) Input source: 122.88-MHz Rohde & Schwarz SMA100A Signal Generator.

(3) Input source RMS Jitter ( $t_{RJIT\_IN}$ ) and Total RMS Jitter ( $t_{RJIT\_OUT}$ ) measured using Agilent E5052 Phase Noise Analyzer. Buffer device random additive jitter computed as:  $t_{RJIT} = \text{SQRT}[(t_{RJIT\_OUT})^2 - (t_{RJIT\_IN})^2]$ .

(4) Input source: 156.25-MHz Rohde & Schwarz SMA100A Signal Generator.

(5) Input source: 312.5-MHz Rohde & Schwarz SMA100A Signal Generator.

## 6.10 Timing Requirements, at $V_{CC} = 3\text{ V to }3.6\text{ V}$

 Refer to [Figure 1](#) and [Figure 2](#).

		MIN	NOM	MAX	UNIT	
$t_{PD}$	Propagation delay	$V_{IN, DIFF, PP} = 0.1\text{ V}$		550	ps	
		$V_{IN, DIFF, PP} = 0.3\text{ V}$		550		
$t_{SK, PP}$	Part-to-part skew			150	ps	
$t_{SK, O}$	Output skew			30	ps	
$t_{SK, P}$	Pulse skew (with 50% duty cycle input)	Crossing-point-to-crossing-point distortion, $f_{OUT} = 100\text{ MHz}$		-50	50	ps
RJIT	Random additive jitter (with 50% duty cycle input) <sup>(1)</sup>	$f_{OUT} = 100\text{ MHz}$ , $V_{IN, SE} = V_{CC}$ , $V_{th} = 1.65\text{ V}$ , 10 kHz to 20 MHz			0.101	ps, RMS
		$f_{OUT} = 100\text{ MHz}$ , $V_{IN, SE} = 0.9\text{ V}$ , $V_{th} = 1.1\text{ V}$ , 10 kHz to 20 MHz			0.130	
		$f_{OUT} = 2\text{ GHz}$ , $V_{IN, DIFF, PP} = 0.2\text{ V}$ , $V_{ICM} = 1\text{ V}$ , 10 kHz to 20 MHz			0.069	
		$f_{OUT} = 100\text{ MHz}$ , $V_{IN, DIFF, PP} = 0.15\text{ V}$ , $V_{ICM} = 1\text{ V}$ , 10 kHz to 20 MHz			0.094	
		$f_{OUT} = 100\text{ MHz}$ , $V_{IN, DIFF, PP} = 1\text{ V}$ , $V_{ICM} = 1\text{ V}$ , 10 kHz to 20 MHz			0.094	
		$f_{OUT} = 122.88\text{ MHz}$ , <sup>(2)(3)</sup> Square Wave, $V_{IN, PP} = 1\text{ V}$ , 12 kHz to 20 MHz			0.057	
		$f_{OUT} = 122.88\text{ MHz}$ , <sup>(2)(3)</sup> Square Wave, $V_{IN, PP} = 1\text{ V}$ , 10 kHz to 20 MHz			0.057	
		$f_{OUT} = 122.88\text{ MHz}$ , <sup>(2)(3)</sup> Square Wave, $V_{IN, PP} = 1\text{ V}$ , 1 kHz to 40 MHz			0.086	
		$f_{OUT} = 156.25\text{ MHz}$ , <sup>(3)(4)</sup> Square Wave, $V_{IN, PP} = 1\text{ V}$ , 12 kHz to 20 MHz			0.048	
		$f_{OUT} = 156.25\text{ MHz}$ , <sup>(3)(4)</sup> Square Wave, $V_{IN, PP} = 1\text{ V}$ , 10 kHz to 20 MHz			0.048	
		$f_{OUT} = 156.25\text{ MHz}$ , <sup>(3)(4)</sup> Square Wave, $V_{IN, PP} = 1\text{ V}$ , 1 kHz to 40 MHz			0.068	
		$f_{OUT} = 312.5\text{ MHz}$ , <sup>(3)(5)</sup> Square Wave, $V_{IN, PP} = 1\text{ V}$ , 12 kHz to 20 MHz			0.030	
$f_{OUT} = 312.5\text{ MHz}$ , <sup>(3)(5)</sup> Square Wave, $V_{IN, PP} = 1\text{ V}$ , 10 kHz to 20 MHz			0.030			
$f_{OUT} = 312.5\text{ MHz}$ , <sup>(3)(5)</sup> Square Wave, $V_{IN, PP} = 1\text{ V}$ , 1 kHz to 40 MHz			0.045			
$t_R/t_F$	Output rise/fall time	20% to 80%		200	ps	

(1) Parameter is specified by characterization. Not tested in production.

(2) Input source: 122.88-MHz Rohde & Schwarz SMA100A Signal Generator.

(3) Input source RMS Jitter ( $t_{RJIT, IN}$ ) and Total RMS Jitter ( $t_{RJIT, OUT}$ ) measured using Agilent E5052 Phase Noise Analyzer. Buffer device random additive jitter computed as:  $t_{RJIT} = \text{SQRT}[(t_{RJIT, OUT})^2 - (t_{RJIT, IN})^2]$ .

(4) Input source: 156.25-MHz Rohde & Schwarz SMA100A Signal Generator.

(5) Input source: 312.5-MHz Rohde & Schwarz SMA100A Signal Generator.

## 6.11 Pin Characteristics

PARAMETER		MIN	TYP	MAX	UNIT
$R_{PULLDOWN}$	Input pulldown resistor		150		k $\Omega$

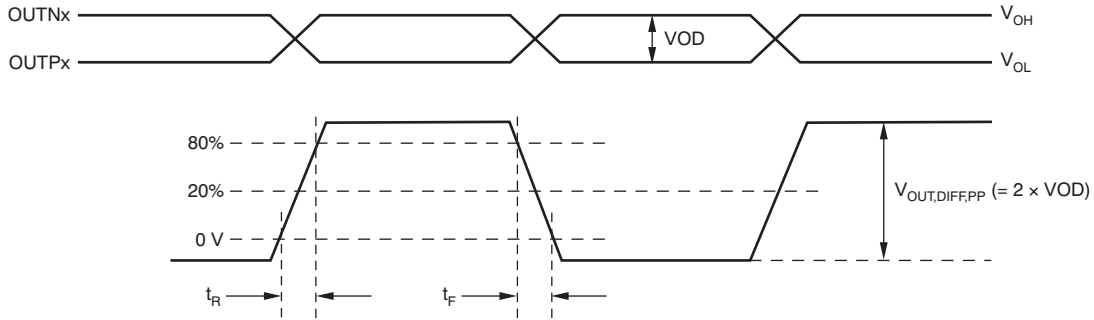
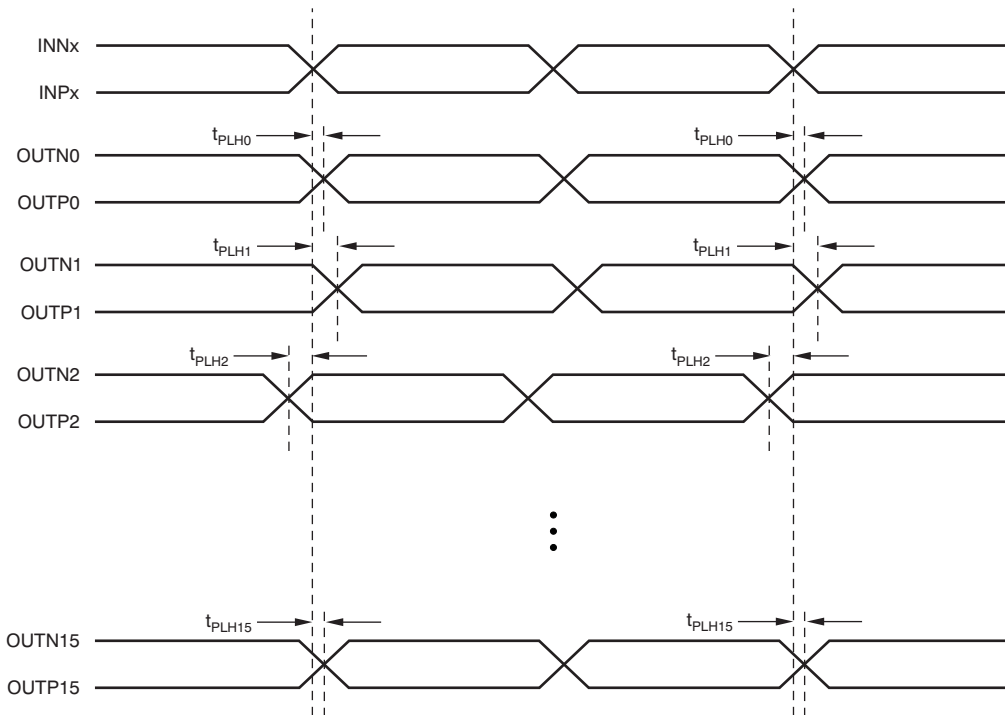


Figure 1. Output Voltage and Rise/Fall Time

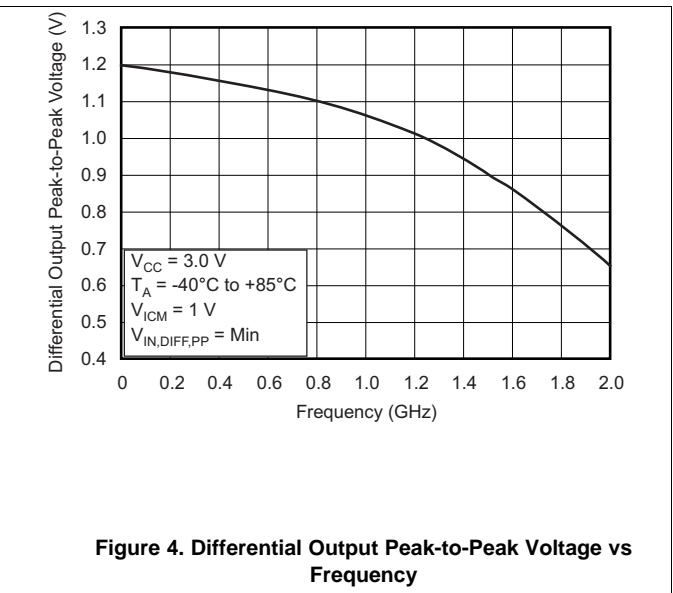
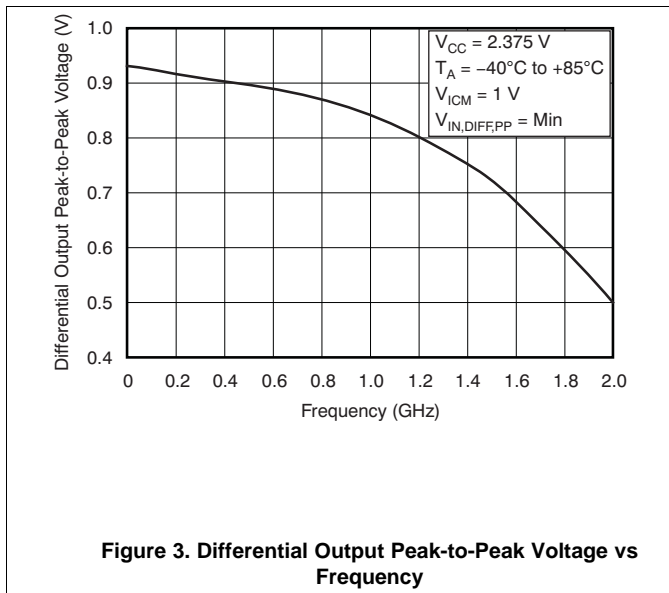


- (1) Output skew is calculated as the greater of the following: As the difference between the fastest and the slowest  $t_{PLHn}$  ( $n = 0, 1, 2, \dots, 15$ ), or as the difference between the fastest and the slowest  $t_{PHLn}$  ( $n = 0, 1, 2, \dots, 15$ ).
- (2) Part-to-part skew is calculated as the greater of the following: As the difference between the fastest and the slowest  $t_{PLHn}$  ( $n = 0, 1, 2, \dots, 15$ ) across multiple devices, or the difference between the fastest and the slowest  $t_{PHLn}$  ( $n = 0, 1, 2, \dots, 15$ ) across multiple devices.

Figure 2. Output and Part-to-Part Skew

## 6.12 Typical Characteristics

at  $T_A = -40^\circ\text{C}$  to  $+85^\circ\text{C}$  (unless otherwise noted)



## 7 Parameter Measurement Information

### 7.1 Test Configurations

Figure 5 through Figure 11 show how the device should be set up for a variety of test configurations.

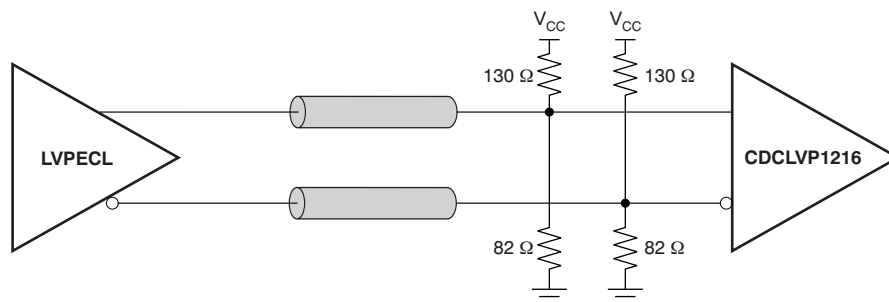


Figure 5. DC-Coupled LVPECL Input During Device Test

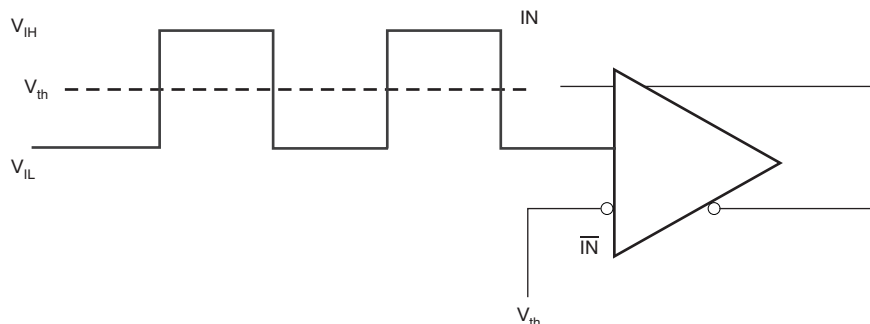


Figure 6. DC-Coupled LVCMOS Input During Device Test

Test Configurations (continued)

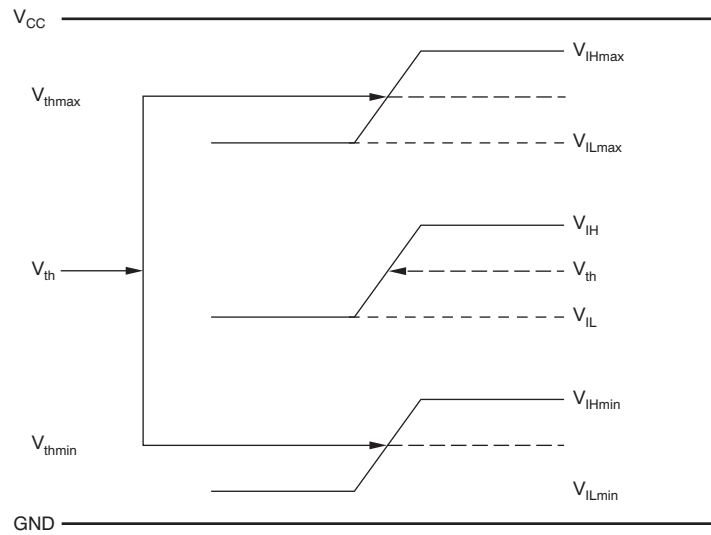
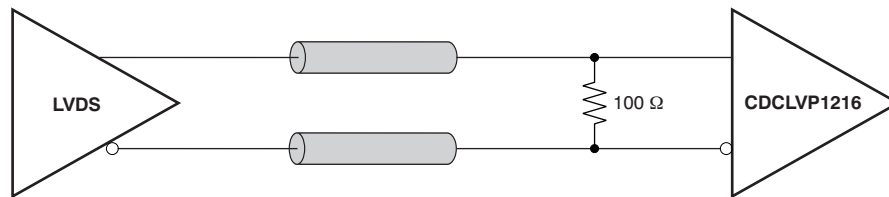
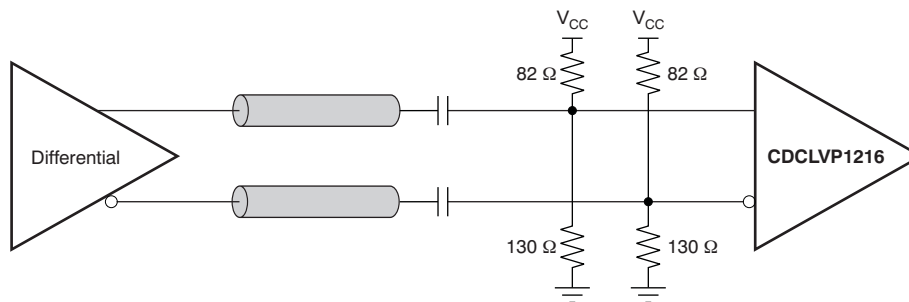
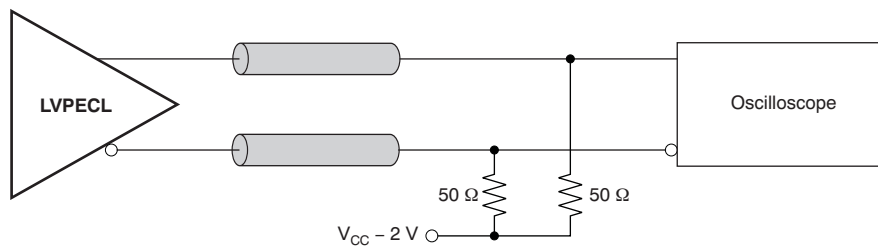
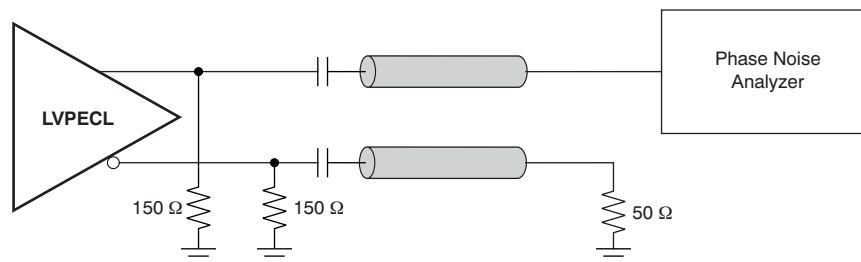


Figure 7.  $V_{th}$  Variation over LVCMOS  $V_{th}$  Levels

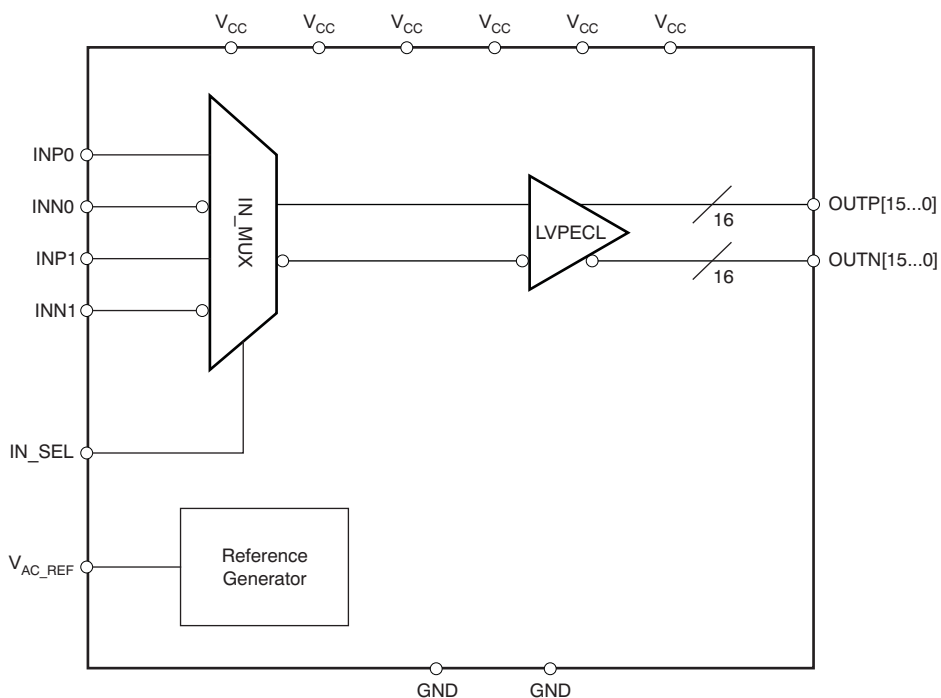
**Test Configurations (continued)**

**Figure 8. DC-Coupled LVDS Input During Device Test**

**Figure 9. AC-Coupled Differential Input to Device**

**Figure 10. LVPECL Output DC Configuration During Device Test**

**Figure 11. LVPECL Output AC Configuration During Device Test**

## 8 Detailed Description

### 8.1 Overview

The CDCLVP1216 uses an open emitter follower stage for its LVPECL outputs. Therefore, proper output biasing and termination are required to ensure correct operation of the device and to maximize output signal integrity. The proper termination for LVPECL outputs is a  $50\ \Omega$  to  $(V_{CC} - 2)\text{ V}$ , but this DC voltage is not readily available on PCB. Therefore, a Thevenin equivalent circuit is worked out for the LVPECL termination in both direct-coupled (DC) and AC-coupled configurations. These configurations are shown in Figure 12 (a and b) for  $V_{CC} = 2.5\text{ V}$  and Figure 13 (a and b) for  $V_{CC} = 3.3\text{ V}$ , respectively. It is recommended to place all resistive components close to either the driver end or the receiver end. If the supply voltage for the driver and receiver is different, AC coupling is required.

### 8.2 Functional Block Diagram



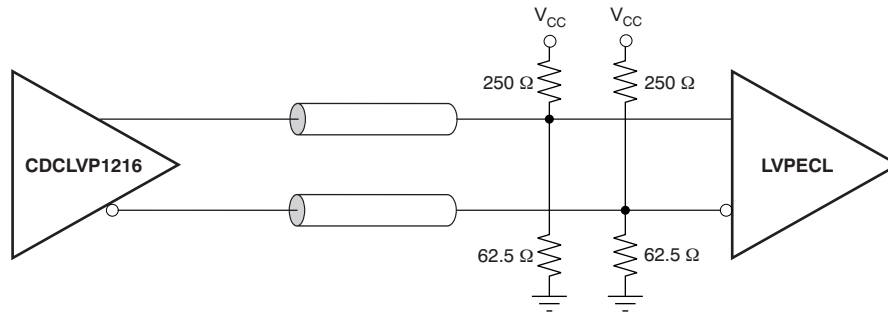
### 8.3 Feature Description

The CDCLVP1216 is a low additive jitter universal to LVPECL fan-out buffer with 2 selectable inputs. The small package, low output skew, and low additive jitter make for a flexible device in demanding applications.

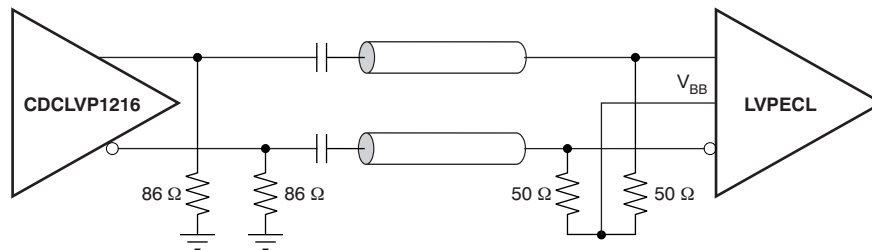
## 8.4 Device Functional Modes

The two inputs of the CDCLVP1216 are internally muxed together and can be selected via the control pin. Unused inputs and outputs can be left floating to reduce overall component cost. Both AC and DC coupling schemes can be used with the CDCLVP1216 to provide greater system flexibility.

### 8.4.1 LVPECL Output Termination



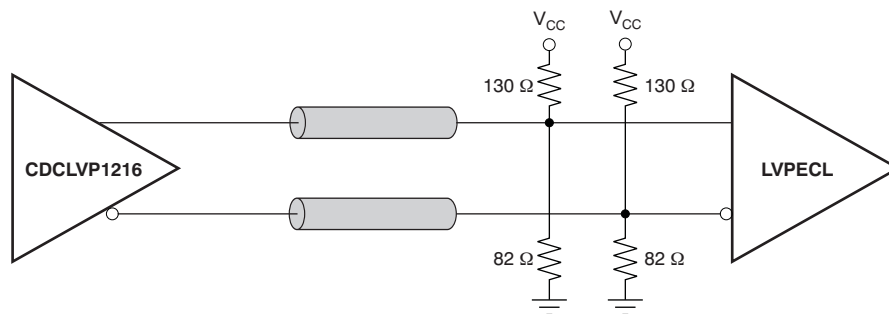
(a) Output DC Termination



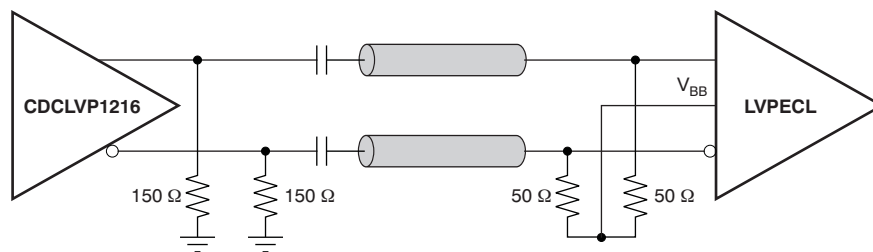
(b) Output AC Termination

**Figure 12. LVPECL Output DC and AC Termination for  $V_{CC} = 2.5\text{ V}$**

Device Functional Modes (continued)



(a) Output DC Termination



(b) Output AC Termination

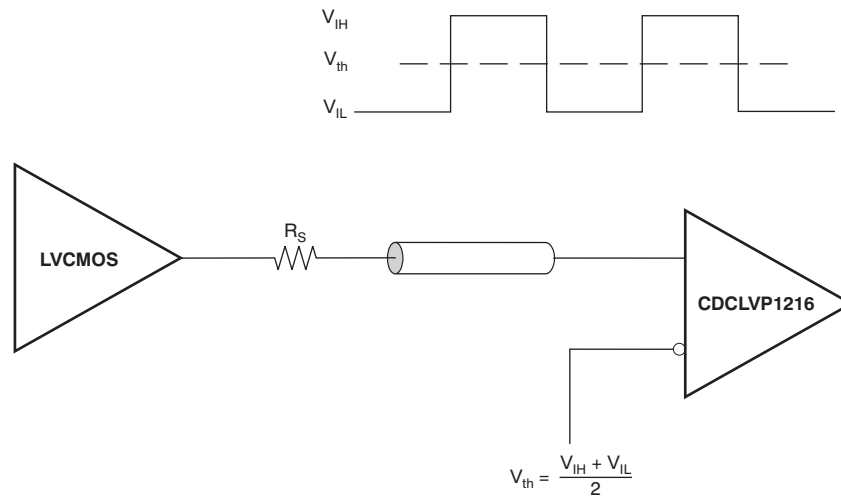
Figure 13. LVPECL Output DC and AC Termination for  $V_{CC} = 3.3\text{ V}$

Table 1. Input Selection Table

IN_SEL	ACTIVE CLOCK INPUT
0	INP0, INN0
1	INP1, INN1

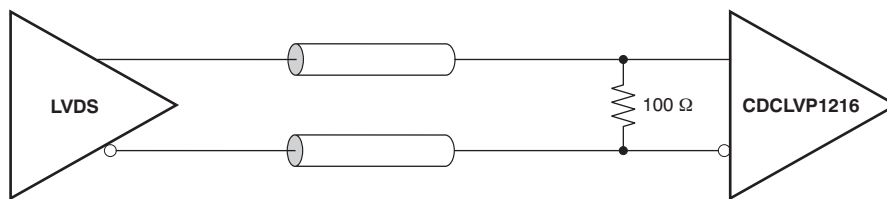
8.4.2 Input Termination

The CDCLVP1216 inputs can be interfaced with LVPECL, LVDS, or LVCMOS drivers. Figure 14 shows how to DC couple an LVCMOS input to the CDCLVP1216. The series resistance ( $R_S$ ) must be placed close to the LVCMOS driver; its value is calculated as the difference between the transmission line impedance and the driver output impedance.

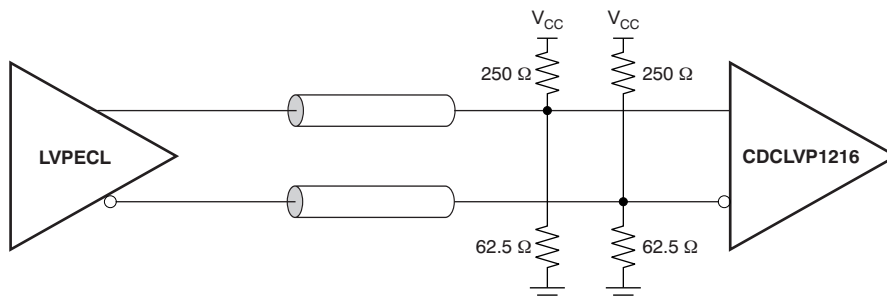


**Figure 14. DC-Coupled LVCMOS Input to CDCLVP1216**

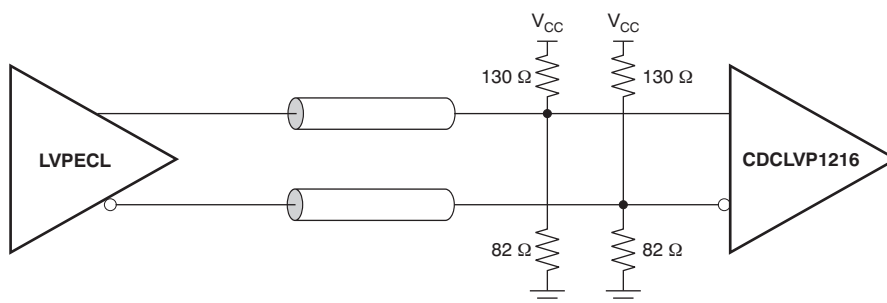
Figure 15 shows how to DC couple LVDS inputs to the CDCLVP1216. Figure 16 and Figure 17 describe the method of DC coupling LVPECL inputs to the CDCLVP1216 for  $V_{CC} = 2.5\text{ V}$  and  $V_{CC} = 3.3\text{ V}$ , respectively.



**Figure 15. DC-Coupled LVDS Inputs to CDCLVP1216**

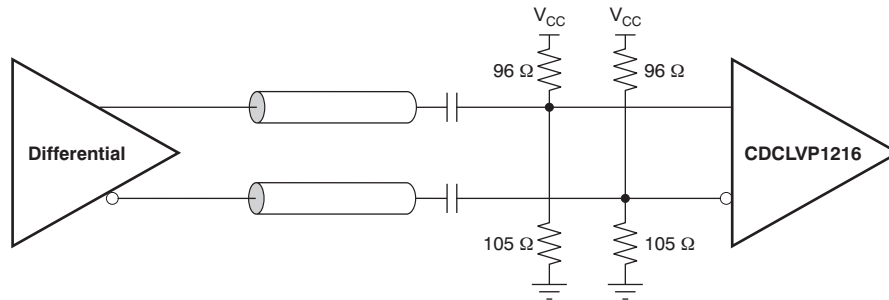


**Figure 16. DC-Coupled LVPECL Inputs to CDCLVP1216 ( $V_{CC} = 2.5\text{ V}$ )**

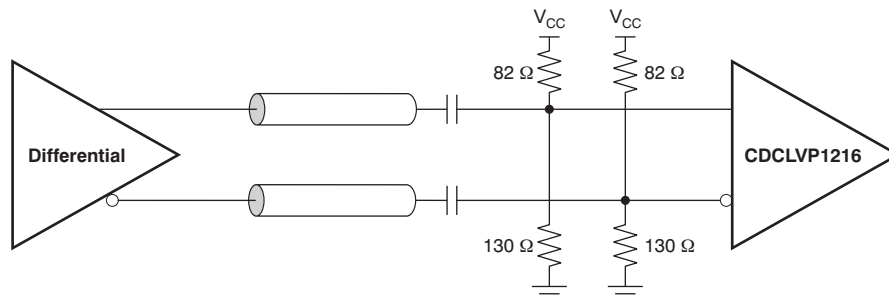


**Figure 17. DC-Coupled LVPECL Inputs to CDCLVP1216 ( $V_{CC} = 3.3\text{ V}$ )**

Figure 18 and Figure 19 show the technique of AC coupling differential inputs to the CDCLVP1216 for  $V_{CC} = 2.5\text{ V}$  and  $V_{CC} = 3.3\text{ V}$ , respectively. TI recommends placing all resistive components close to either the driver end or the receiver end. If the supply voltages of the driver and receiver are different, AC coupling is required.



**Figure 18. AC-Coupled Differential Inputs to CDCLVP1216 ( $V_{CC} = 2.5\text{ V}$ )**



**Figure 19. AC-Coupled Differential Inputs to CDCLVP1216 ( $V_{CC} = 3.3\text{ V}$ )**

## 9 Applications and Implementation

### NOTE

Information in the following applications sections is not part of the TI component specification, and TI does not warrant its accuracy or completeness. TI's customers are responsible for determining suitability of components for their purposes. Customers should validate and test their design implementation to confirm system functionality.

### 9.1 Application Information

The CDCLVP1216 is a low additive jitter LVPECL fan-out buffer that can generate four copies of two selectable LVPECL, LVDS, or LVC MOS inputs. The CDCLVP1216 can accept reference clock frequencies up to 2 GHz while providing low output skew.

### 9.2 Typical Application

Figure 20 shows a fan-out buffer for line-card application.

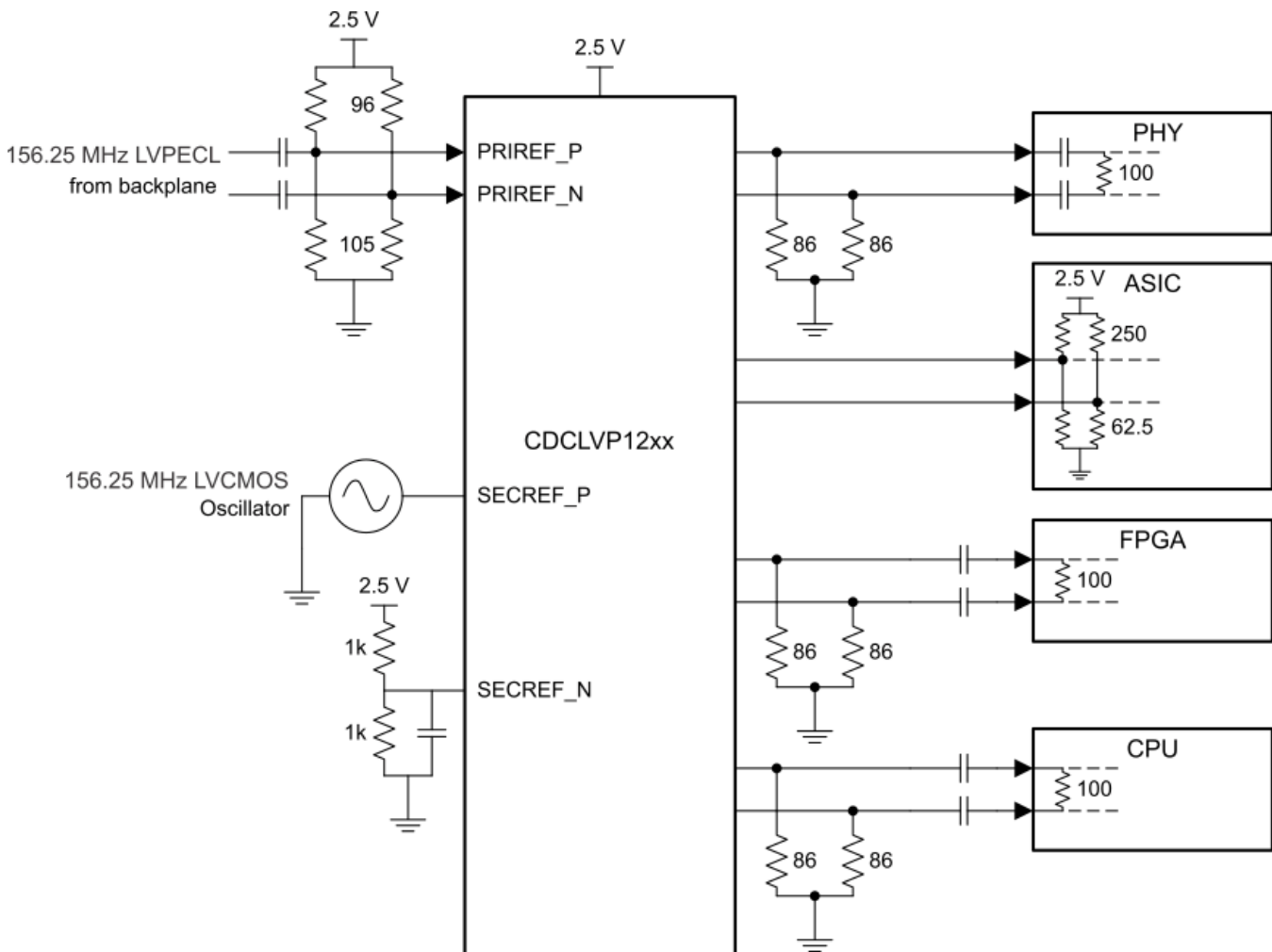


Figure 20. CDCLVP1216 Typical Application

## Typical Application (continued)

### 9.2.1 Design Requirements

The CDCLVP1216 shown in Figure 20 is configured to be able to select two inputs, a 156.25-MHz LVPECL clock from the backplane, or a secondary 156.25-MHz LVCMOS 2.5-V oscillator. Either signal can be then fanned out to desired devices, as shown.

The configuration example is driving 4 LVPECL receivers in a line-card application with the following properties:

- The PHY device has internal AC coupling and appropriate termination and biasing. The CDCLVP1216 must be provided with 86-Ω emitter resistors near the driver for proper operation.
- The ASIC is capable of DC coupling with a 2.5-V LVPECL driver such as the CDCLVP1216. This ASIC features internal termination so no additional components are needed.
- The FPGA requires external AC coupling but has internal termination. Again, 86-Ω emitter resistors are placed near the CDCLVP1216, and 0.1 μF are placed to provide AC coupling. Similarly, the CPU is internally terminated and requires external AC coupling capacitors.

### 9.2.2 Detailed Design Procedure

Refer to [Input Termination](#) for proper input terminations, dependent on single ended or differential inputs.

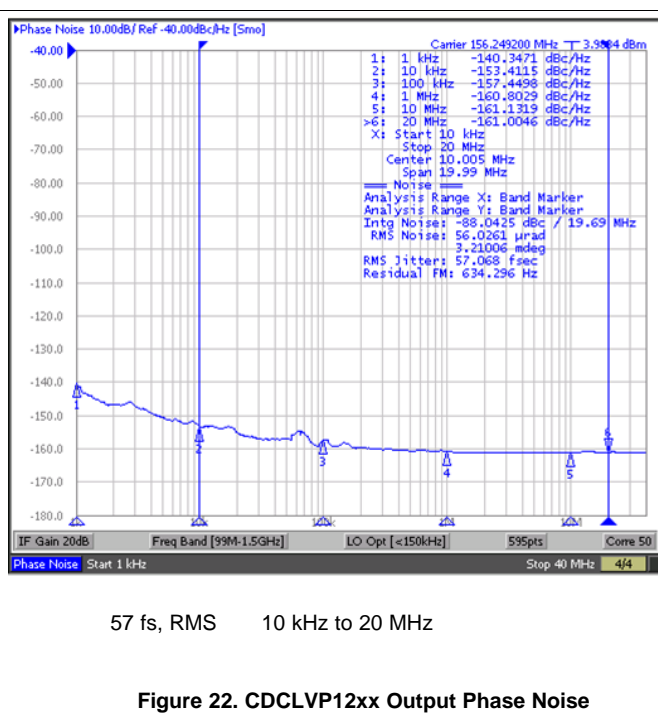
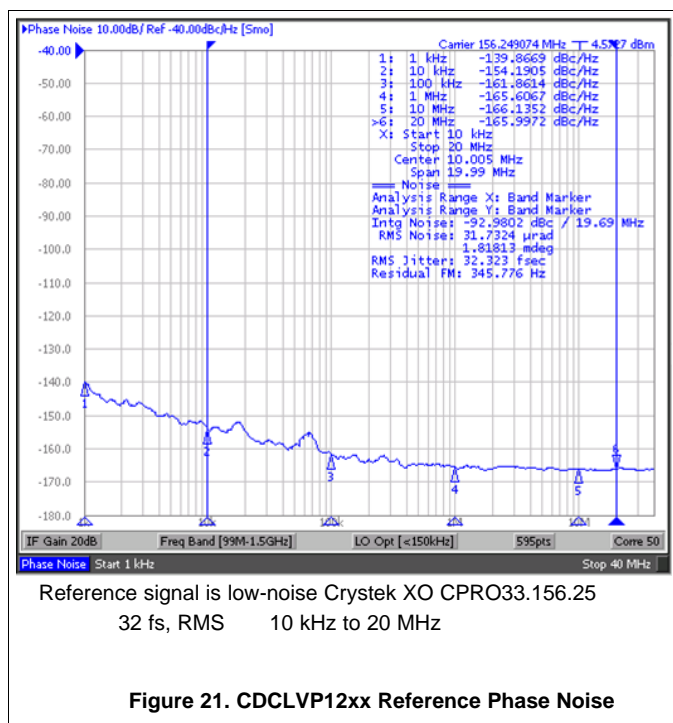
Refer to [LVPECL Output Termination](#) for output termination schemes depending on the receiver application.

Unused outputs can be left floating.

In Figure 20, the PHY, ASIC, and FPGA/CPU require different schemes. Power supply filtering and bypassing is critical for low-noise applications.

See [Power Supply Recommendations](#) for recommended filtering techniques. A reference layout is provided on the CDCLVP1216 Evaluation Module, *Low Additive Phase Noise Clock Buffer Evaluation Board User's Guide (SCAU029)*.

### 9.2.3 Application Curves



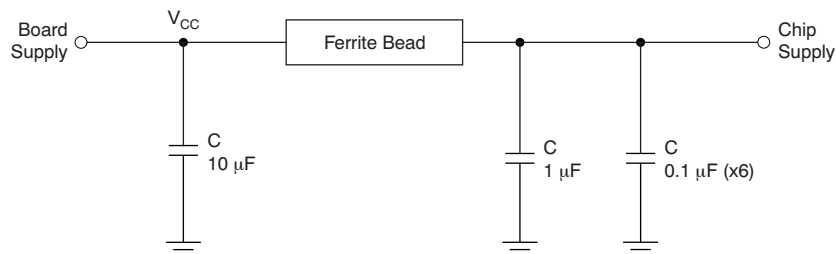
The low additive noise of the CDCLVP12xx can be shown in this line-card application. The low noise 156.25 MHz XO with 32-fs, RMS jitter drives the CDCLVP12xx, resulting in 57 fs, RMS when integrated from 10 kHz to 20 MHz. The resultant additive jitter is a low 47 fs, RMS for this configuration.

## 10 Power Supply Recommendations

High-performance clock buffers are sensitive to noise on the power supply, which can dramatically increase the additive jitter of the buffer. Thus, it is essential to reduce noise from the system power supply, especially when jitter or phase noise is very critical to applications.

Filter capacitors are used to eliminate the low-frequency noise from the power supply, where the bypass capacitors provide the very low impedance path for high-frequency noise and guard the power-supply system against the induced fluctuations. These bypass capacitors also provide instantaneous current surges as required by the device and should have low equivalent series resistance (ESR). To properly use the bypass capacitors, they must be placed very close to the power-supply pins and laid out with short loops to minimize inductance. TI recommends adding as many high-frequency (for example, 0.1- $\mu\text{F}$ ) bypass capacitors as there are supply pins in the package. It is recommended, but not required, to insert a ferrite bead between the board power supply and the chip power supply that isolates the high-frequency switching noises generated by the clock driver; these beads prevent the switching noise from leaking into the board supply. It is imperative to choose an appropriate ferrite bead with very low DC resistance in order to provide adequate isolation between the board supply and the chip supply, as well as to maintain a voltage at the supply pins that is greater than the minimum voltage required for proper operation.

Figure 23 shows this recommended power-supply decoupling method.



**Figure 23. Power-Supply Decoupling**

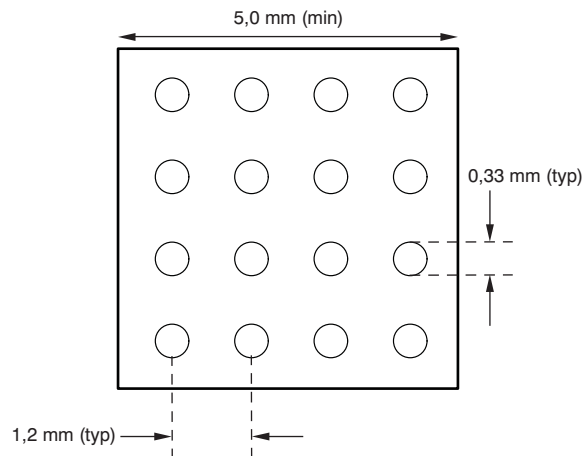
## 11 Layout

### 11.1 Layout Guidelines

Power consumption of the CDCLVP1216 can be high enough to require attention to thermal management. For reliability and performance reasons, the die temperature must be limited to a maximum of 125°C. That is, as an estimate, ambient temperature ( $T_A$ ) plus device power consumption times  $R_{\theta JA}$  should not exceed 125°C.

The device package has an exposed pad that provides the primary heat removal path to the printed circuit board (PCB). To maximize the heat dissipation from the package, a thermal landing pattern including multiple vias to a ground plane must be incorporated into the PCB within the footprint of the package. The exposed pad must be soldered down to ensure adequate heat conduction out of the package. [Figure 24](#) shows a recommended land and via pattern.

### 11.2 Layout Example



**Figure 24. Recommended PCB Layout**

### 11.3 Thermal Considerations

The CDCLVP1216 supports high temperatures on the printed circuit board (PCB) measured at the thermal pad. The system designer needs to ensure that the maximum junction temperature is not exceeded.  $\Psi_{JB}$  can allow the system designer to measure the board temperature with a fine gauge thermocouple and back calculate the junction temperature using [Equation 1](#). Note that  $\Psi_{JB}$  is close to  $R_{\theta JB}$  because 75% to 95% of the heat of a device is dissipated by the PCB. For further information, refer to [SPRA953](#) and [SLUA566](#).

$$T_{\text{junction}} = T_{\text{PCB}} + (\Psi_{JB} \times \text{Power}) \quad (1)$$

#### Example:

Calculation of the junction-lead temperature with a 4-layer JEDEC test board using four thermal vias:

$$T_{\text{PCB}} = 105^{\circ}\text{C}$$

$$\Psi_{JB} = 8.3^{\circ}\text{C/W}$$

$$\text{Power}_{\text{inclTerm}} = I_{\text{max}} \times V_{\text{max}} = 675 \text{ mA} \times 3.6 \text{ V} = 2430 \text{ mW (maximum power consumption including termination resistors)}$$

$$\text{Power}_{\text{exclTerm}} = 1826 \text{ mW (maximum power consumption excluding termination resistors; see [SLYT127](#) for further details)}$$

$$\Delta T_{\text{Junction}} = \Psi_{JB} \times \text{Power}_{\text{exclTerm}} = 8.3^{\circ}\text{C/W} \times 1826 \text{ mW} = 15.16^{\circ}\text{C}$$

$$T_{\text{Junction}} = \Delta T_{\text{Junction}} + T_{\text{Chassis}} = 15.16^{\circ}\text{C} + 105^{\circ}\text{C} = 120.16^{\circ}\text{C (the maximum junction temperature of } 125^{\circ}\text{C is not violated)}$$

## 12 Device and Documentation Support

### 12.1 Documentation Support

#### 12.1.1 Related Documentation

For related documentation see the following:

- CDCLVP1216 Evaluation Module, *Low Additive Phase Noise Clock Buffer Evaluation Board User's Guide* ([SCAU029](#))
- *Using Thermal Calculation Tools for Analog Components* ([SLUA566](#))

### 12.2 Community Resources

The following links connect to TI community resources. Linked contents are provided "AS IS" by the respective contributors. They do not constitute TI specifications and do not necessarily reflect TI's views; see TI's [Terms of Use](#).

**TI E2E™ Online Community** *TI's Engineer-to-Engineer (E2E) Community*. Created to foster collaboration among engineers. At [e2e.ti.com](#), you can ask questions, share knowledge, explore ideas and help solve problems with fellow engineers.

**Design Support** *TI's Design Support* Quickly find helpful E2E forums along with design support tools and contact information for technical support.

### 12.3 Trademarks

E2E is a trademark of Texas Instruments.  
All other trademarks are the property of their respective owners.

### 12.4 Electrostatic Discharge Caution



These devices have limited built-in ESD protection. The leads should be shorted together or the device placed in conductive foam during storage or handling to prevent electrostatic damage to the MOS gates.

### 12.5 Glossary

[SLYZ022](#) — *TI Glossary*.

This glossary lists and explains terms, acronyms, and definitions.

## 13 Mechanical, Packaging, and Orderable Information

The following pages include mechanical, packaging, and orderable information. This information is the most current data available for the designated devices. This data is subject to change without notice and revision of this document. For browser-based versions of this data sheet, refer to the left-hand navigation.

**PACKAGING INFORMATION**

Orderable Device	Status (1)	Package Type	Package Drawing	Pins	Package Qty	Eco Plan (2)	Lead/Ball Finish (6)	MSL Peak Temp (3)	Op Temp (°C)	Device Marking (4/5)	Samples
CDCLVP1216RGZR	ACTIVE	VQFN	RGZ	48	2500	Green (RoHS & no Sb/Br)	CU NIPDAU	Level-3-260C-168 HR	-40 to 85	CDCLVP 1216	<a href="#">Samples</a>
CDCLVP1216RGZT	ACTIVE	VQFN	RGZ	48	250	Green (RoHS & no Sb/Br)	CU NIPDAU	Level-3-260C-168 HR	-40 to 85	CDCLVP 1216	<a href="#">Samples</a>

(1) The marketing status values are defined as follows:

**ACTIVE:** Product device recommended for new designs.

**LIFEBUY:** TI has announced that the device will be discontinued, and a lifetime-buy period is in effect.

**NRND:** Not recommended for new designs. Device is in production to support existing customers, but TI does not recommend using this part in a new design.

**PREVIEW:** Device has been announced but is not in production. Samples may or may not be available.

**OBsolete:** TI has discontinued the production of the device.

(2) **RoHS:** TI defines "RoHS" to mean semiconductor products that are compliant with the current EU RoHS requirements for all 10 RoHS substances, including the requirement that RoHS substance do not exceed 0.1% by weight in homogeneous materials. Where designed to be soldered at high temperatures, "RoHS" products are suitable for use in specified lead-free processes. TI may reference these types of products as "Pb-Free".

**RoHS Exempt:** TI defines "RoHS Exempt" to mean products that contain lead but are compliant with EU RoHS pursuant to a specific EU RoHS exemption.

**Green:** TI defines "Green" to mean the content of Chlorine (Cl) and Bromine (Br) based flame retardants meet JS709B low halogen requirements of <=1000ppm threshold. Antimony trioxide based flame retardants must also meet the <=1000ppm threshold requirement.

(3) MSL, Peak Temp. - The Moisture Sensitivity Level rating according to the JEDEC industry standard classifications, and peak solder temperature.

(4) There may be additional marking, which relates to the logo, the lot trace code information, or the environmental category on the device.

(5) Multiple Device Markings will be inside parentheses. Only one Device Marking contained in parentheses and separated by a "-" will appear on a device. If a line is indented then it is a continuation of the previous line and the two combined represent the entire Device Marking for that device.

(6) Lead/Ball Finish - Orderable Devices may have multiple material finish options. Finish options are separated by a vertical ruled line. Lead/Ball Finish values may wrap to two lines if the finish value exceeds the maximum column width.

**Important Information and Disclaimer:**The information provided on this page represents TI's knowledge and belief as of the date that it is provided. TI bases its knowledge and belief on information provided by third parties, and makes no representation or warranty as to the accuracy of such information. Efforts are underway to better integrate information from third parties. TI has taken and continues to take reasonable steps to provide representative and accurate information but may not have conducted destructive testing or chemical analysis on incoming materials and chemicals. TI and TI suppliers consider certain information to be proprietary, and thus CAS numbers and other limited information may not be available for release.

In no event shall TI's liability arising out of such information exceed the total purchase price of the TI part(s) at issue in this document sold by TI to Customer on an annual basis.



## TAPE AND REEL INFORMATION



### QUADRANT ASSIGNMENTS FOR PIN 1 ORIENTATION IN TAPE



\*All dimensions are nominal

Device	Package Type	Package Drawing	Pins	SPQ	Reel Diameter (mm)	Reel Width W1 (mm)	A0 (mm)	B0 (mm)	K0 (mm)	P1 (mm)	W (mm)	Pin1 Quadrant
CDCLVP1216RGZR	VQFN	RGZ	48	2500	330.0	16.4	7.3	7.3	1.5	12.0	16.0	Q2
CDCLVP1216RGZT	VQFN	RGZ	48	250	180.0	16.4	7.3	7.3	1.5	12.0	16.0	Q2

**TAPE AND REEL BOX DIMENSIONS**


\*All dimensions are nominal

Device	Package Type	Package Drawing	Pins	SPQ	Length (mm)	Width (mm)	Height (mm)
CDCLVP1216RGZR	VQFN	RGZ	48	2500	350.0	350.0	43.0
CDCLVP1216RGZT	VQFN	RGZ	48	250	213.0	191.0	55.0

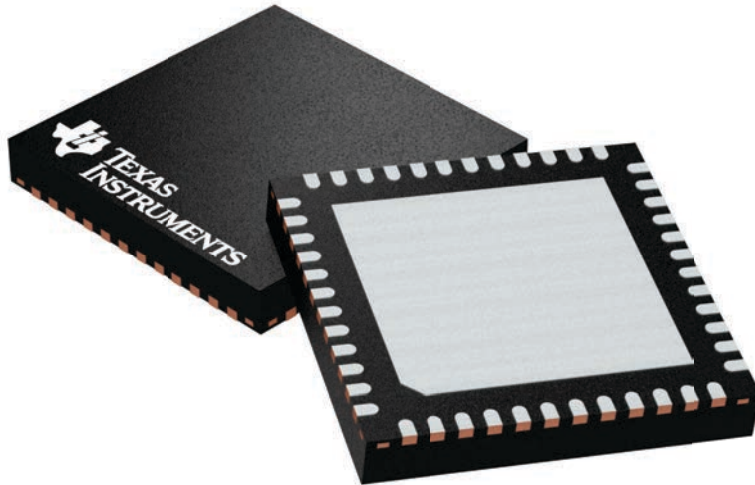
## GENERIC PACKAGE VIEW

**RGZ 48**

**VQFN - 1 mm max height**

7 x 7, 0.5 mm pitch

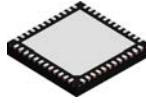
PLASTIC QUADFLAT PACK- NO LEAD



Images above are just a representation of the package family, actual package may vary.  
Refer to the product data sheet for package details.

4224671/A

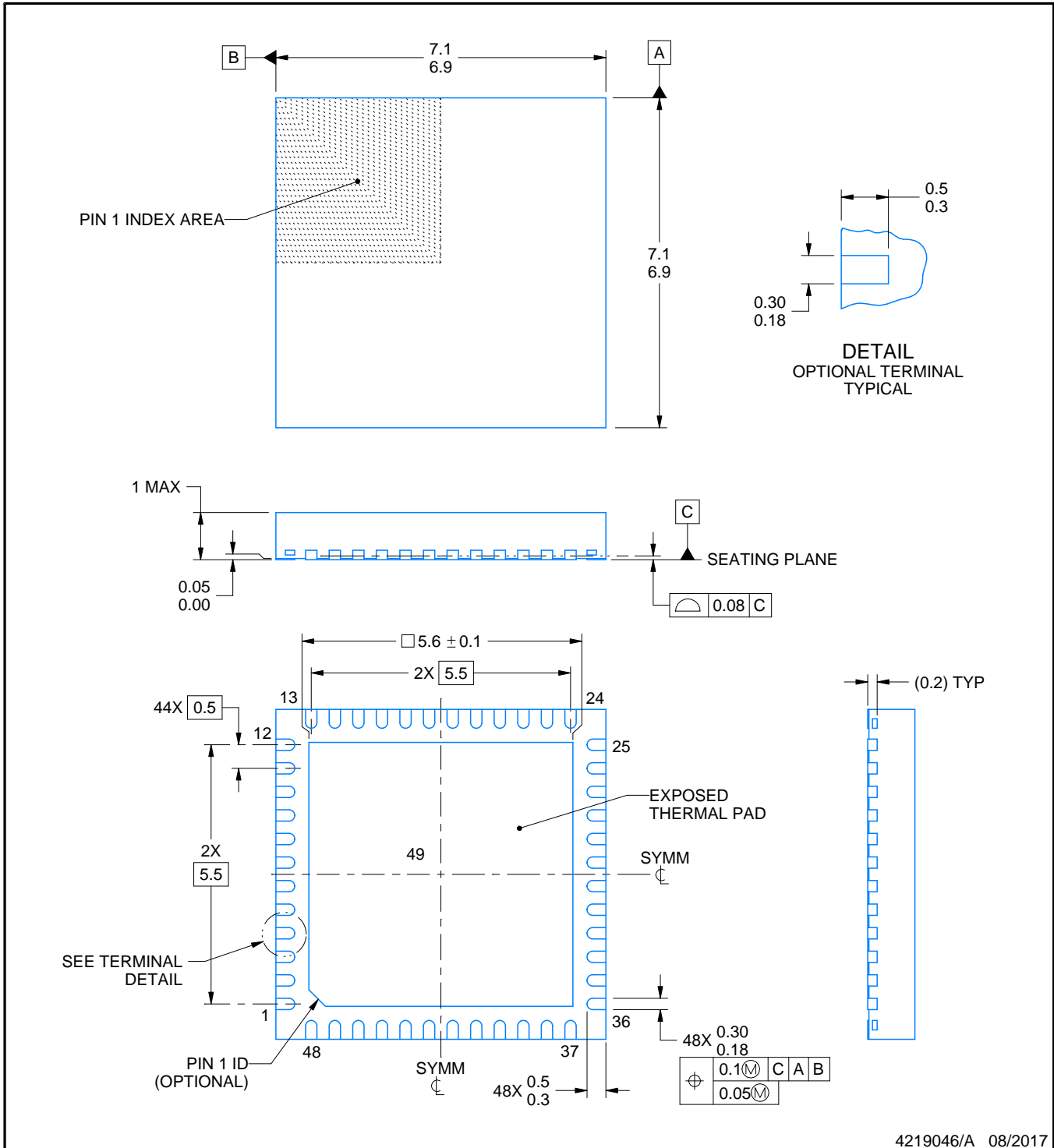
RGZ0048D



PACKAGE OUTLINE

VQFN - 1 mm max height

PLASTIC QUAD FLATPACK - NO LEAD



4219046/A 08/2017

NOTES:

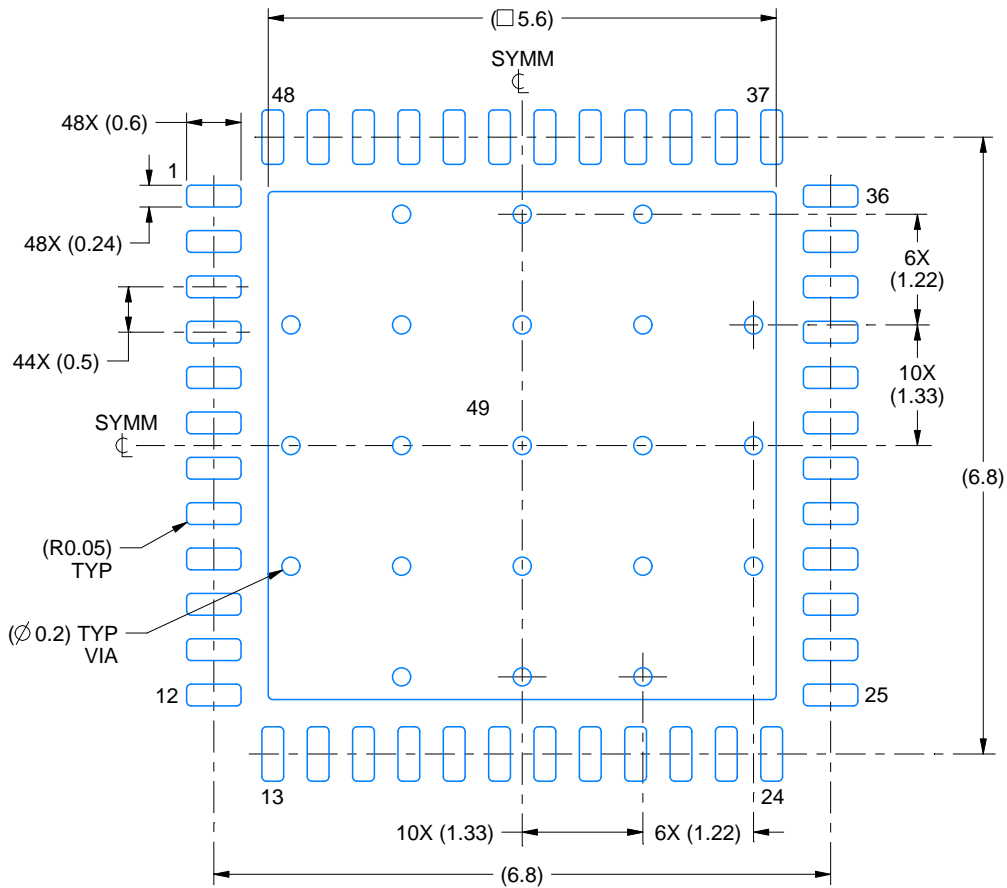
1. All linear dimensions are in millimeters. Any dimensions in parenthesis are for reference only. Dimensioning and tolerancing per ASME Y14.5M.
2. This drawing is subject to change without notice.
3. The package thermal pad must be soldered to the printed circuit board for thermal and mechanical performance.

# EXAMPLE BOARD LAYOUT

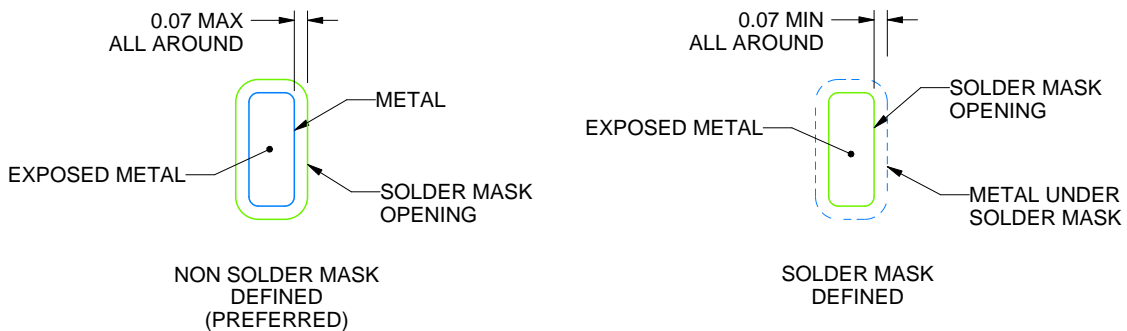
**RGZ0048D**

**VQFN - 1 mm max height**

PLASTIC QUAD FLATPACK - NO LEAD



**LAND PATTERN EXAMPLE**  
EXPOSED METAL SHOWN  
SCALE:12X



**SOLDER MASK DETAILS**

4219046/A 08/2017

NOTES: (continued)

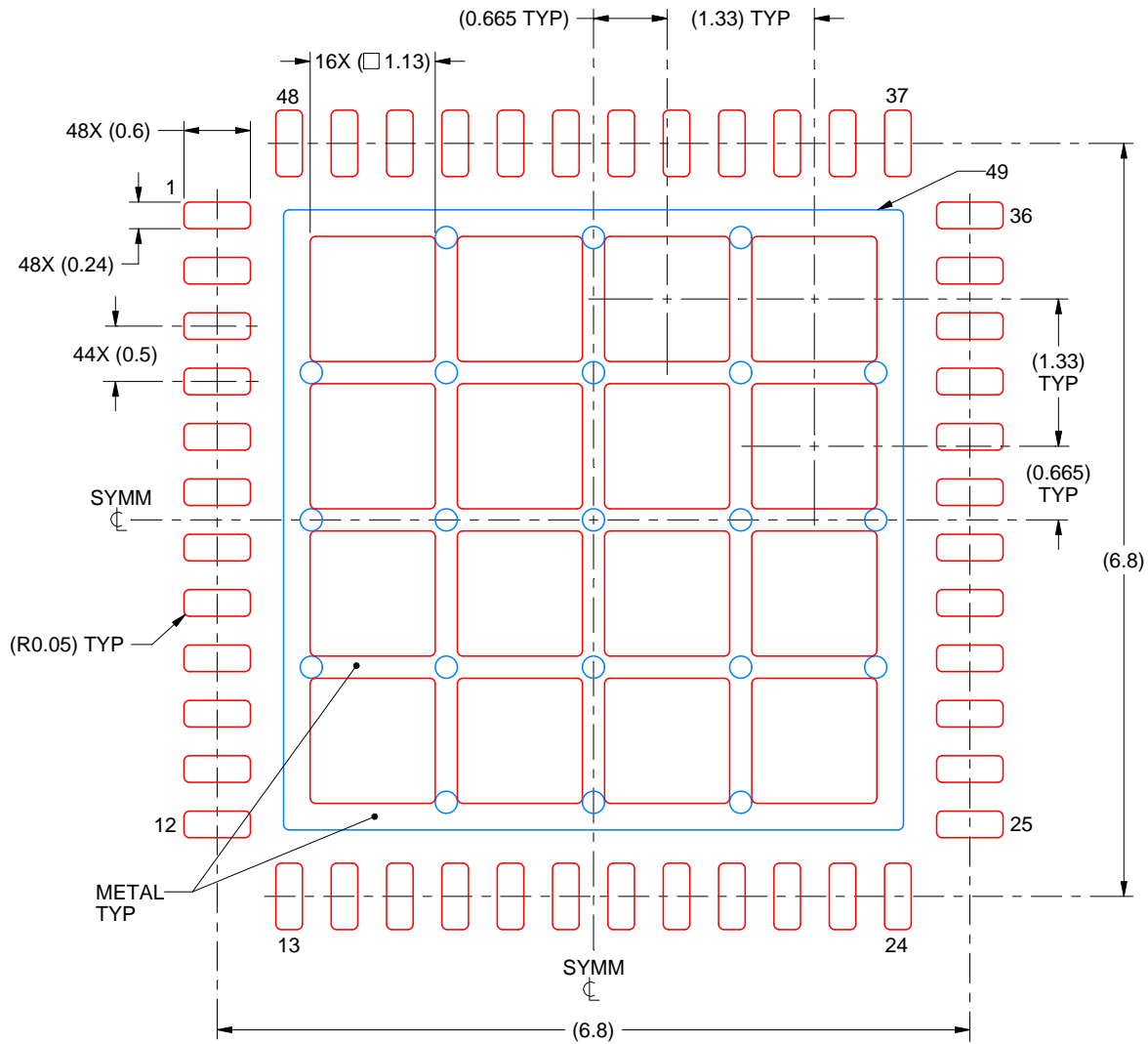
4. This package is designed to be soldered to a thermal pad on the board. For more information, see Texas Instruments literature number SLUA271 ([www.ti.com/lit/sluea271](http://www.ti.com/lit/sluea271)).
5. Vias are optional depending on application, refer to device data sheet. If any vias are implemented, refer to their locations shown on this view. It is recommended that vias under paste be filled, plugged or tented.

# EXAMPLE STENCIL DESIGN

RGZ0048D

VQFN - 1 mm max height

PLASTIC QUAD FLATPACK - NO LEAD



**SOLDER PASTE EXAMPLE**  
 BASED ON 0.125 mm THICK STENCIL

EXPOSED PAD 49  
 66% PRINTED SOLDER COVERAGE BY AREA UNDER PACKAGE  
 SCALE:15X

4219046/A 08/2017

NOTES: (continued)

6. Laser cutting apertures with trapezoidal walls and rounded corners may offer better paste release. IPC-7525 may have alternate design recommendations.

## IMPORTANT NOTICE AND DISCLAIMER

TI PROVIDES TECHNICAL AND RELIABILITY DATA (INCLUDING DATASHEETS), DESIGN RESOURCES (INCLUDING REFERENCE DESIGNS), APPLICATION OR OTHER DESIGN ADVICE, WEB TOOLS, SAFETY INFORMATION, AND OTHER RESOURCES "AS IS" AND WITH ALL FAULTS, AND DISCLAIMS ALL WARRANTIES, EXPRESS AND IMPLIED, INCLUDING WITHOUT LIMITATION ANY IMPLIED WARRANTIES OF MERCHANTABILITY, FITNESS FOR A PARTICULAR PURPOSE OR NON-INFRINGEMENT OF THIRD PARTY INTELLECTUAL PROPERTY RIGHTS.

These resources are intended for skilled developers designing with TI products. You are solely responsible for (1) selecting the appropriate TI products for your application, (2) designing, validating and testing your application, and (3) ensuring your application meets applicable standards, and any other safety, security, or other requirements. These resources are subject to change without notice. TI grants you permission to use these resources only for development of an application that uses the TI products described in the resource. Other reproduction and display of these resources is prohibited. No license is granted to any other TI intellectual property right or to any third party intellectual property right. TI disclaims responsibility for, and you will fully indemnify TI and its representatives against, any claims, damages, costs, losses, and liabilities arising out of your use of these resources.

TI's products are provided subject to TI's Terms of Sale ([www.ti.com/legal/termsofsale.html](http://www.ti.com/legal/termsofsale.html)) or other applicable terms available either on [ti.com](http://ti.com) or provided in conjunction with such TI products. TI's provision of these resources does not expand or otherwise alter TI's applicable warranties or warranty disclaimers for TI products.

Mailing Address: Texas Instruments, Post Office Box 655303, Dallas, Texas 75265  
Copyright © 2019, Texas Instruments Incorporated