

# FB-HSB - Converter

2316379

<https://www.phoenixcontact.com/us/products/2316379>



Please be informed that the data shown in this PDF document is generated from our online catalog. Please find the complete data in the user documentation. Our general terms of use for downloads are valid.

Head station for monitoring one PROFIBUS network



## Product description

PROFIBUS head station

## Your advantages

- Powerful, embedded web server for configuration and access to network diagnostics
- One communication interface module can drive up to ten individual PROFIBUS DP or PROFIBUS PA modules
- Manage and configure PROFIBUS field devices using FDT/DTM

## Commercial data

Item number	2316379
Packing unit	1 pc
Minimum order quantity	1 pc
Note	Made to order (non-returnable)
Sales key	DN11
Product key	DNC135
GTIN	4055626071145
Weight per piece (including packing)	406.8 g
Weight per piece (excluding packing)	161 g
Customs tariff number	85176200
Country of origin	NL

## Technical data

### Notes

#### Note on application

Note on application	Only for industrial use
---------------------	-------------------------

### Product properties

Product type	Device coupler
--------------	----------------

### Electrical properties

#### Supply

Supply voltage range	10.8 V DC ... 26.4 V DC
Max. current consumption	800 mA

### Connection data

#### Supply

Conductor cross section, flexible	0.20 mm <sup>2</sup> ... 2.50 mm <sup>2</sup>
Conductor cross section, rigid	0.20 mm <sup>2</sup> ... 2.50 mm <sup>2</sup>
Conductor cross section AWG	24 ... 12

### Interfaces

#### Data: Ethernet

Connection method	RJ45
No. of channels	1
Conductor cross section flexible max.	2.5 mm <sup>2</sup>
Conductor cross section flexible min.	0.2 mm <sup>2</sup>
Conductor cross section, rigid max.	2.5 mm <sup>2</sup>
Conductor cross section, rigid min.	0.2 mm <sup>2</sup>
Conductor cross section AWG max.	12
Conductor cross section AWG min.	24

### Dimensions

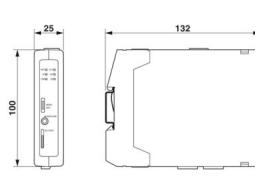
Dimensional drawing	
Width	25 mm
Height	100 mm
Depth	132 mm

## Material specifications

Color	green
-------	-------

## Environmental and real-life conditions

### Ambient conditions

Degree of protection	IP20
Ambient temperature (operation)	-20 °C ... 60 °C
Ambient temperature (storage/transport)	-20 °C ... 60 °C
Permissible humidity (operation)	5 % ... 95 % (non-condensing)
Permissible humidity (storage/transport)	5 % ... 95 % (non-condensing)

## Approvals

### Conformity/Approvals

UL, USA / Canada	UL 508 Listed
UL, Canada	CSA C22.2 No. 142

## Standards and regulations

### Standards/regulations

Standards/regulations	Ring wave noise immunity in acc. with IEC 61000-4-12
-----------------------	--

### Standards/regulations

Standards/regulations	Dry heat in acc. with IEC 61131-2
-----------------------	-----------------------------------

### Standards/regulations

Standards/regulations	Damp heat in acc. with IEC 61131-2
-----------------------	------------------------------------

### Standards/regulations

Standards/regulations	Shock and vibration in acc. with EN 61131-2 and EN 50178
-----------------------	--

### PROFIBUS standardization

Standards/regulations	IEC 61158-2
-----------------------	-------------

# FB-HSB - Converter

2316379

<https://www.phoenixcontact.com/us/products/2316379>



## Drawings

Dimensional drawing

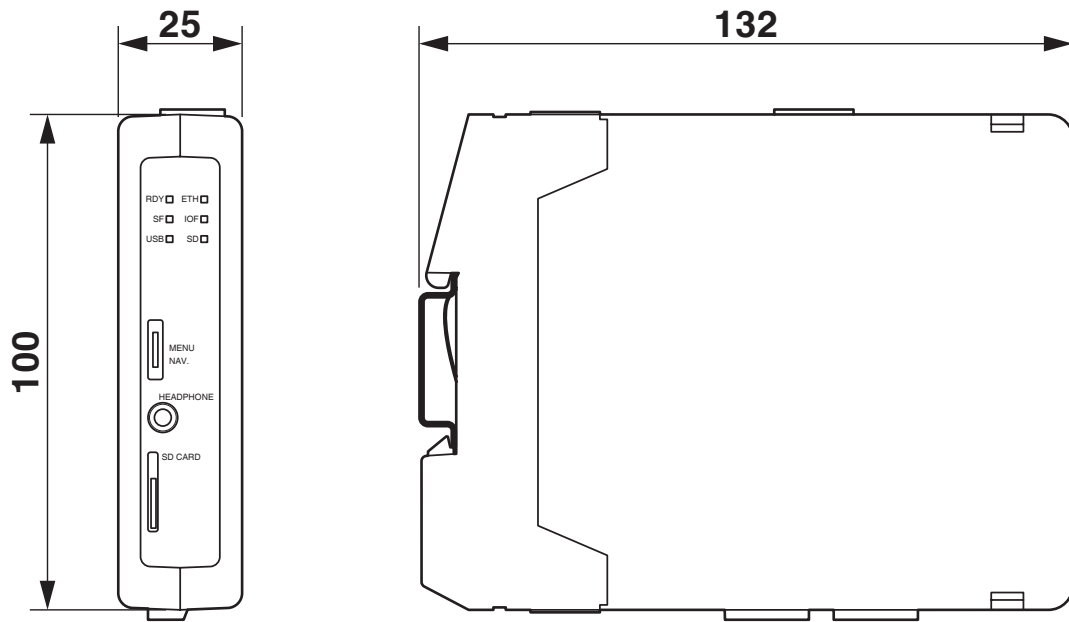

# FB-HSB - Converter

2316379

<https://www.phoenixcontact.com/us/products/2316379>



## Classifications

### ECLASS

ECLASS-11.0	27242610
ECLASS-12.0	27242610
ECLASS-13.0	27242610

### ETIM

ETIM 9.0	EC001600
----------	----------

### UNSPSC

UNSPSC 21.0	32151600
-------------	----------

## Environmental product compliance

### China RoHS

Environment friendly use period (EFUP)	EFUP-50
	An article-related China RoHS declaration table can be found in the download area for the respective article under "Manufacturer declaration". For all articles with EFUP-E, no China RoHS declaration table issued and required.

### EU REACH SVHC

REACH candidate substance (CAS No.)	No substance above 0.1 wt%
-------------------------------------	----------------------------

Phoenix Contact 2024 © - all rights reserved  
<https://www.phoenixcontact.com>

Phoenix Contact USA  
586 Fulling Mill Road  
Middletown, PA 17057, United States  
(+717) 944-1300  
[info@phoenixcon.com](mailto:info@phoenixcon.com)