

PRODUCT NUMBER
59112-001

A

B

C

D

A

B

C

D

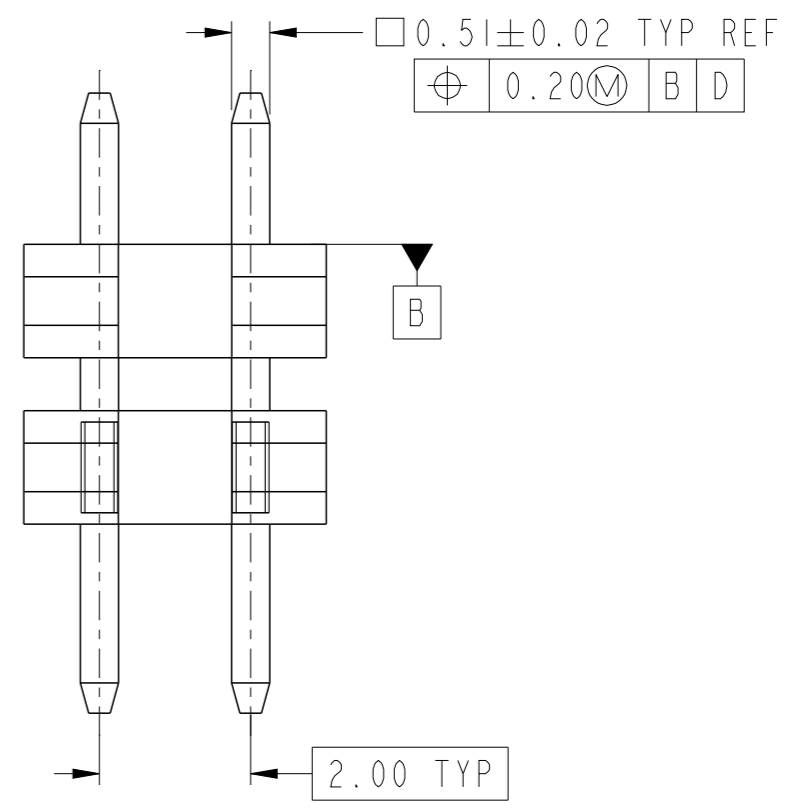
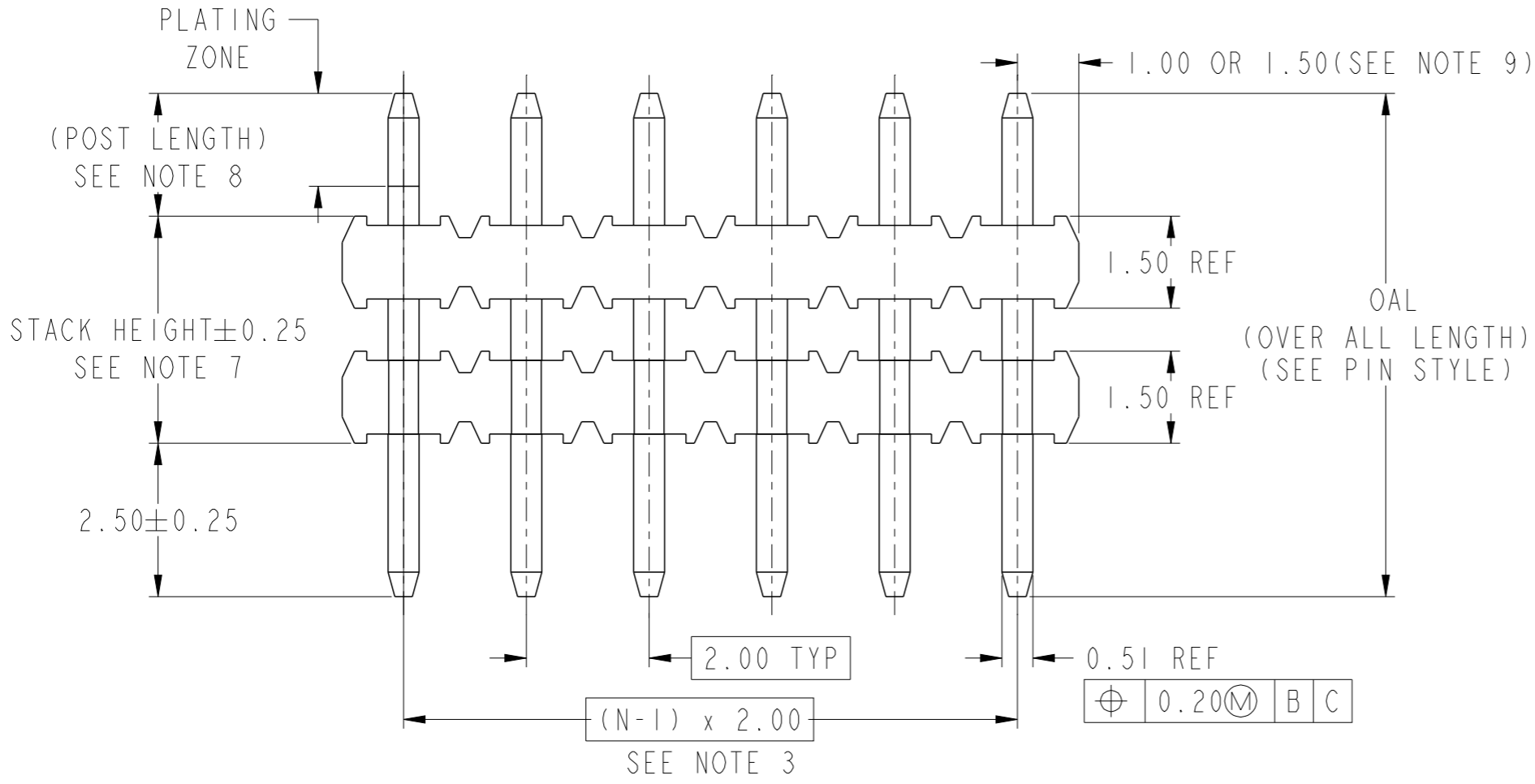
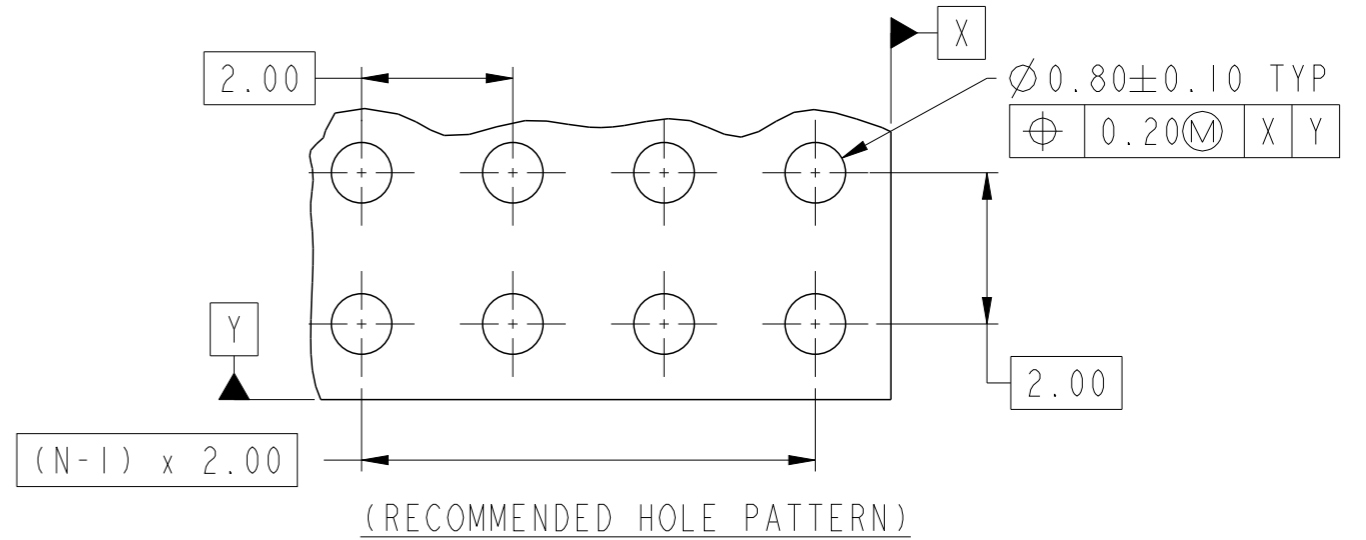
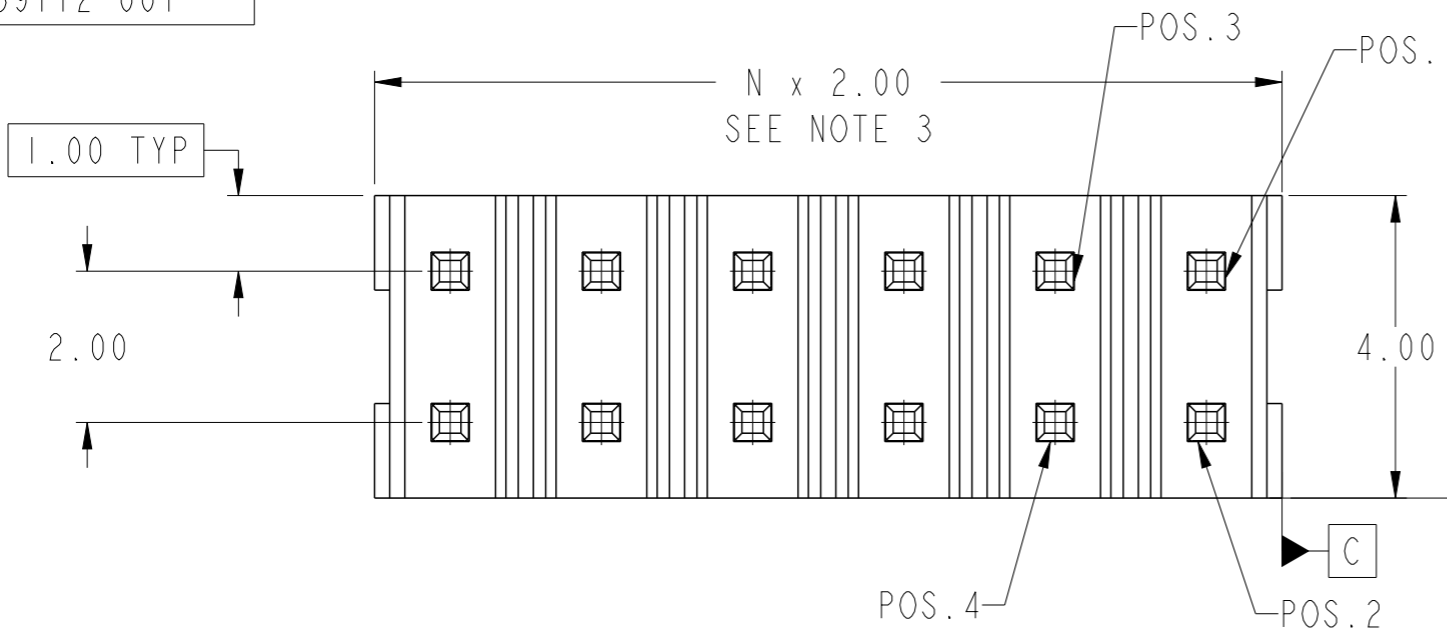

Copyright FCI.



spec ref	-	dr	wcadmin	2010/10/31	projection	MM	size	A3	scale	10:1
tolerance std	ISO 406 ISO 1101	eng	Guo-Min Sun	2013/12/12			ecn no	ELX-N-16500-1		
surface	ISO 1302	chr	-	2013/12/12			product family	MINITEK	rel level	Released
	linear	0.X	±0.5		2.00MM UNSHROUDED HEADER BOARD TO BOARD THRU-HOLE		dwg no 59112	rev N		
		0.XX	±0.25							
		0.XXX	±0.15							
	angular	0°	±3°	www.fci.com	cat. no.	-	Product - Customer Drw		sheet 1 of 2	

