

## HXAS179-92LF

### General Description

The HXAS179-92LF is a GaAs MMIC specifically designed for L, S-band SPDT switches, developed with mobile phones and other L, S-band applications in mind.

This device can be controlled using a voltage range of 1.8 to 5.

3 V for precise switching. Operating within a frequency range from 0.05 to 3.

0 GHz, it offers low insertion loss and excellent isolation. The HXAS179-92LF is

housed in a compact 6-pin super minimold package, making it suitable for high-density surface mounting.

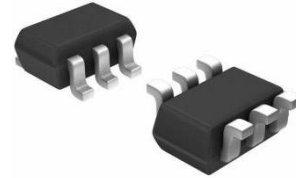

SOT-363

### Features

- **Switch control voltage**

$V_{cont(H)} = 1.8$  to  $5.3V$  (3.0V TYP.)

$V_{cont(L)} = -0.2$  to  $+0.2V$  (3.0V TYP.)

- **Low insertion loss**

$L_{ins1} = 0.25$  dB TYP. @  $f = 0.05$  to  $0.5$  GHz,  $V_{cont(H)} = 3.0$  V,  $V_{cont(L)} = 0$  V

$L_{ins2} = 0.25$  dB TYP. @  $f = 0.5$  to  $1.0$  GHz,  $V_{cont(H)} = 3.0$  V,  $V_{cont(L)} = 0$  V

$L_{ins3} = 0.30$  dB TYP. @  $f = 1.0$  to  $2.0$  GHz,  $V_{cont(H)} = 3.0$  V,  $V_{cont(L)} = 0$  V

$L_{ins4} = 0.35$  dB TYP. @  $f = 2.0$  to  $2.5$  GHz,  $V_{cont(H)} = 3.0$  V,  $V_{cont(L)} = 0$  V

$L_{ins5} = 0.35$  dB TYP. @  $f = 2.5$  to  $3.0$  GHz,  $V_{cont(H)} = 3.0$  V,  $V_{cont(L)} = 0$  V

- **Handling power**

$P_{in(1dB)} = +27.0$  dBm TYP. @  $f = 0.5$  to  $3.0$  GHz,  $V_{cont(H)} = 3.0$  V,  $V_{cont(L)} = 0$  V

$P_{in(1dB)} = +20.0$  dBm TYP. @  $f = 0.5$  to  $3.0$  GHz,  $V_{cont(H)} = 1.8$  V,  $V_{cont(L)} = 0$  V

### Applications

- W-LAN, WLL and Bluetooth™ etc.
- L, S-band digital cellular or cordless telephone

### PIN CONFIGURATIONS

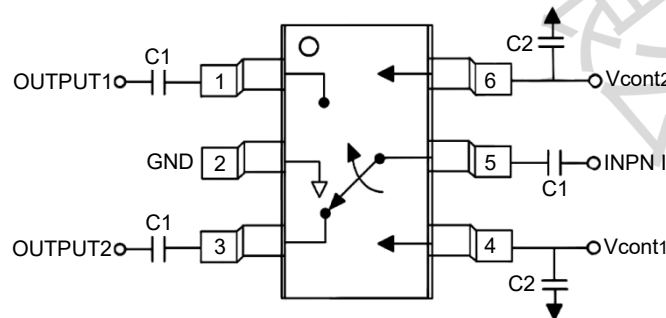

DC blocking capacitors C1 are required on all RF ports.  
 $C1 = 56pF$ ,  $C2 = 1000pF$  for operation  $> 500MHz$

### TRUTH TABLE

Vcont1	Vcont2	INPUT-OUTPUT1	INPUT-OUTPUT2
Low	High	ON	OFF
High	Low	OFF	ON

www.haixindianzi.com

## ABSOLUTE MAXIMUM RATINGS (TA=+25°C, unless otherwise specified)

Parameter	Symbol	Ratings	Unit
Switch Control Voltage	Vcont	+6.0 <sup>A</sup>	v
Input Power	Pin	+30	dBm
Operating Ambient Temperature	TA	-45 to +85	°C
Storage Temperature	Tstg	-55 to +150	°C

### Notes

A. Vcont1 - Vcont2 ≤ 6.0V

## RECOMMENDED OPERATING RANGE (TA=+25°C, unless otherwise specified)

Parameter	Symbol	MIN.	TYP.	MAX.	Unit
Switch Control Voltage (H)	Vcont (H)	1.8	3.0	6.3	V
Switch Control Voltage (L)	Vcont (L)	-0.2	0	0.2	V

## ELECTRICAL CHARACTERISTICS

(TA=+25°C, Vcont(H)=3.0 V, Vcont(L)=0 V, DC cut capacitors =100 pF, unless otherwise specified)

Parameter	Symbol	Test Conditions	MIN.	TYP.	MAX.	Unit
Insertion Loss 1	Lins1	f=0.05 to 0.5 GHz <sup>A</sup>		0.25	0.45	dB
Insertion Loss 2	Lins2	f=0.5 to 1.0 GHz		0.25	0.45	dB
Insertion Loss 3	Lins3	f=1.0 to 2.0 GHz		0.30	0.50	dB
Insertion Loss 4	Lins4	f=2.0 to 2.5 GHz		0.35	0.55	dB
Insertion Loss 5	Lins5	f=2.5 to 3.0 GHz		0.35	0.60	dB
Isolation 1	ISL1	f=0.05 to 0.5 GHz <sup>A</sup>	29	32		dB
Isolation 2	ISL2	f=0.5 to 1.0 GHz	25	28		dB
Isolation 3	ISL3	f=1.0 to 2.0 GHz	24	27		dB
Isolation 4	ISL4	f=2.0 to 2.5 GHz	23	26		dB
Isolation 5	ISL5	f=2.5 to 3.0 GHz	21	24		dB
Input Return Loss 1	RLin1	f=0.05 to 0.5 GHz <sup>A</sup>	15	20		dB
Input Return Loss 2	RLin2	f=0.5 to 3.0 GHz	15	20		dB
Output Return Loss 1	RLout1	f=0.05 to 0.5 GHz <sup>A</sup>	15	20		dB
Output Return Loss 2	RLout2	f=0.5 to 3.0 GHz	15	20		dB
0.1 dB Loss Compression Input Power <sup>B</sup>	Pin(0.1dB)	f=2.0/2.5 GHz	+21.0	+23.0		dBm
		f=0.5 to 3.0 GHz		+23.0		dBm
1 dB Loss Compression Input Power <sup>C</sup>	Pin(1dB)	f=0.5 to 3.0 GHz		+27.0		dBm
2nd Harmonics	2fo	f=2.0GHz, Pin=+15dBm		-55	-47	dBc
		f=2.5GHz, Pin=+15dBm		-55	-47	dBc
3rd Harmonics	3fo	f=2.0GHz, Pin=+15dBm		-55	-47	dBc
		f=2.5GHz, Pin=+15dBm		-55	-47	dBc
Intermodulation Intercept Point	IIP <sub>3</sub>	f=0.5 to 3.0 GHz, 2 tone, Pn=+16 dBm, 5 MHz spacing		+58		dBm
Switch Control Current	Icont			4	20	μA
Switch Control Speed	tsw	50%CTL to 90/10%RF		20	200	ns

### Notes

A. DC cut capacitors =1000 pF at f=0.05 to 0.5 GHz

B. Pin(0.1 dB) is measured the input power level when the insertion loss increases more 0.1 dB than that of linear range.

C. Pin(1 dB) is measured the input power level when the insertion loss increases more 1 dB than that of linear range.

## ELECTRICAL CHARACTERISTICS

(TA=+25°C, Vcomt(H)=1.8 V, Vcont(L)=0 V, DC cut capacitors =100 pF, unless otherwise specified)

Parameter	Symbol	Test Conditions	MIN.	TYP.	MAX.	Unit
Insertion Loss 6	Lins6	f =0.05 to 0.5 GHz <sup>A</sup>		0.25	0.50	dB
Insertion Loss 7	Lins7	f=0.5 to 1.0 GHz		0.25	0.50	dB
Insertion Loss 8	Lins8	f=1.0 to 2.0 GHz		0.30	0.55	dB
Insertion Loss 9	Lins9	f=2.0 to 2.5 GHz		0.35	0.60	dB
Insertion Loss 10	Lins10	f=2.5 to 3.0 GHz		0.35	0.65	dB
Isolation 6	ISL6	f =0.05 to 0.5 GHz <sup>A</sup>	27	30		dB
Isolation 7	ISL7	f=0.5 to 2.0 GHz	23	27		dB
Isolation 8	ISL8	f=2.0 to 2.5 GHz	21	25		dB
Isolation 9	ISL9	f=2.5 to 3.0 GHz	20	24		dB
Input Return Loss 3	RLin3	f=0.05 to 3.0 GHz <sup>A</sup>	15	20		dB
Output Return Loss 3	RLout3	f =0.05 to 3.0 GHz <sup>A</sup>	15	20		dB
0.1 dB Loss Compression Input Power <sup>B</sup>	P <sub>In(0.1dB)</sub>	f=2.0/2.5 GHz	+14.0	+17.0		dBm
		f=0.5 to 3.0 GHz		+17.0		dBm
1 dB Loss Compression Input Power <sup>C</sup>	P <sub>In(1dB)</sub>	f=0.5 to 3.0 GHz		+20.0		dBm
Switch Control Current	I <sub>cont</sub>			4	20	μA
Switch Control Speed	t <sub>sw</sub>	50%CTL to 90/10%RF		20	200	ns

### Notes

A. DC cut capacitors =1000 pF at f =0.05 to 0.5 GHz

B. P<sub>In(0.1 dB)</sub> is measured the input power level when the insertion loss increases more 0.1 dB than that of linear range.

C. P<sub>In(1dB)</sub> is measured the input power level when the insertion loss increases more 1 dB than that of linear range.

### Caution

It is essential to use DC blocking capacitors when utilizing this device. The value of the DC blocking capacitors must be chosen based on the frequency of operation, bandwidth, switching speed, and the actual board conditions of your system. The recommended range for DC blocking capacitor values is less than 100 pF.

### EVALUATION CIRCUIT

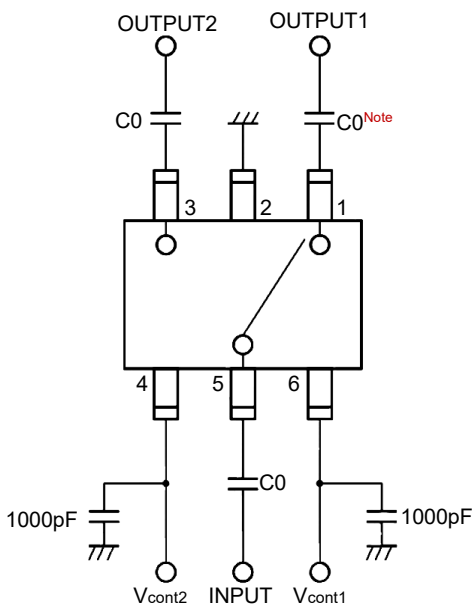

### Note

C0:0.05 to 0.5 GHz 1000 pF  
:0.5 to 3.0 GHz 100 pF

The application circuits and their parameters are for reference purposes only and are not intended for actual design implementation.

## TERISTICSTYPICAL CHARACTERISTICS

(TA=+25°C,Vcont(H)=3.0 V,Vcont(L)=0 V,DC cut capacitors =100 pF,unless otherwise specified)

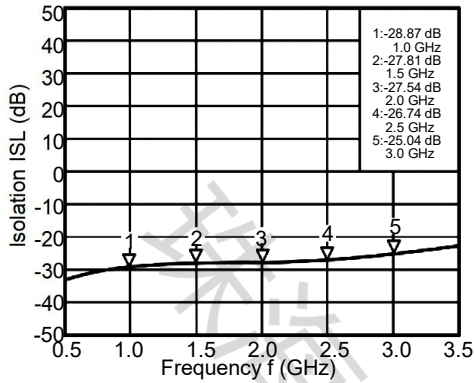

INPUT-OUTPUT1 ISOLATION vs.FREQUENCY

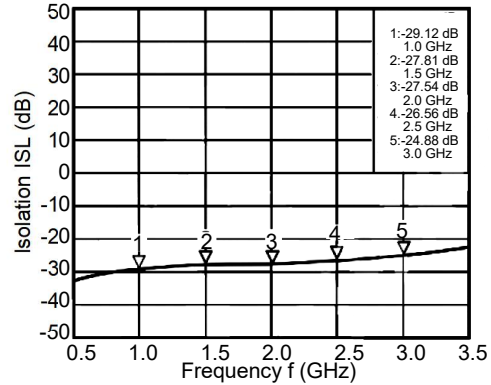

INPUT-OUTPUT2 ISOLATION vs.FREQUENCY

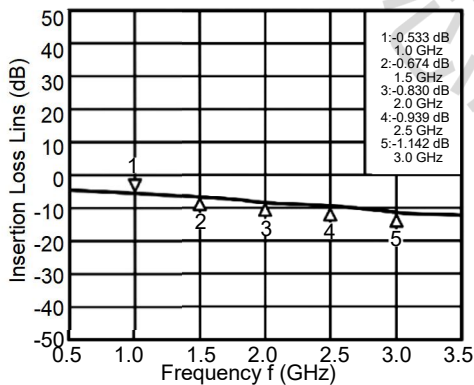

INPUT-OUTPUT1 ISOLATION vs.FREQUENCY

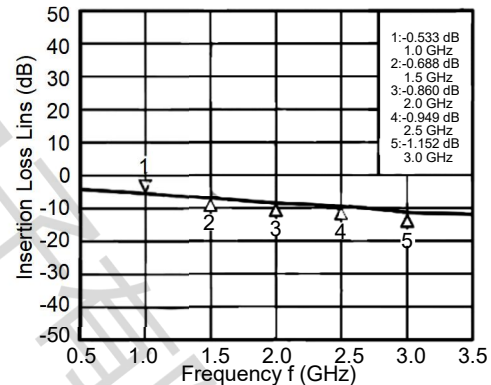

INPUT-OUTPUT2 ISOLATION vs.FREQUENCY

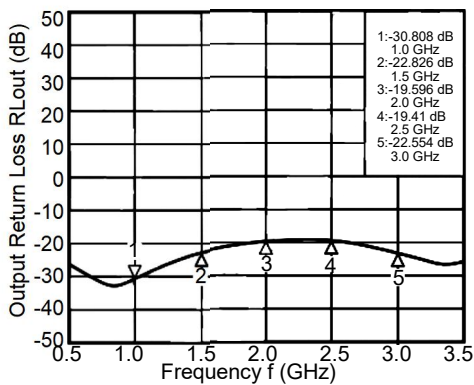

INPUT-OUTPUT1 ISOLATION vs.FREQUENCY

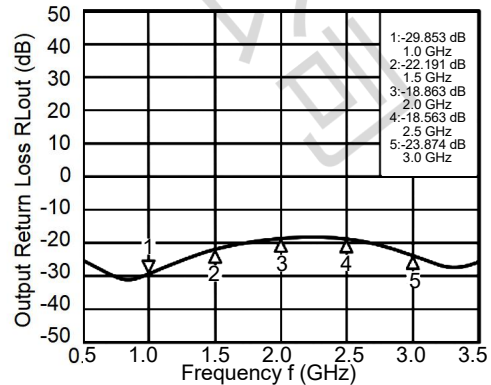

INPUT-OUTPUT2 ISOLATION vs.FREQUENCY

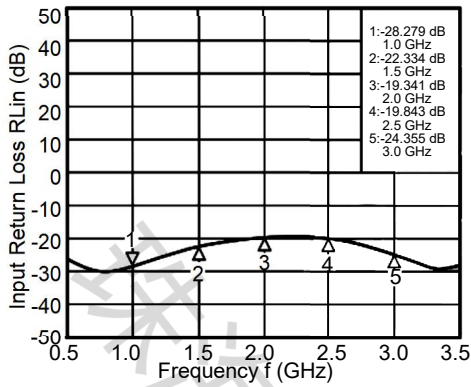

**INPUT-OUTPUT1 ISOLATION vs.FREQUENCY**

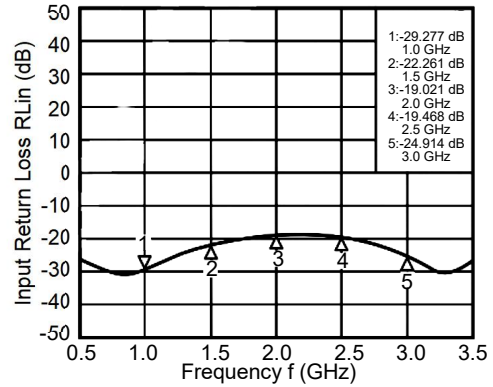

**INPUT-OUTPUT2 ISOLATION vs.FREQUENCY**

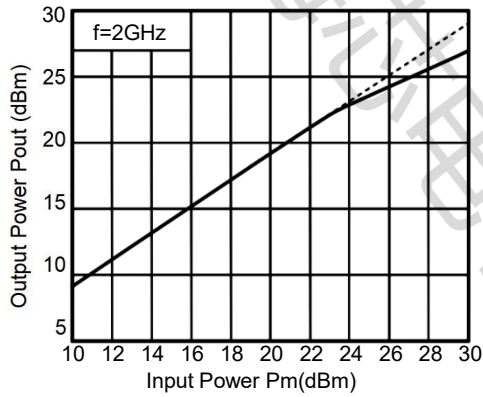

**OUTPUT POWER Vs.INPUT POWER**

## DIMENSIONAL DRAWINGS

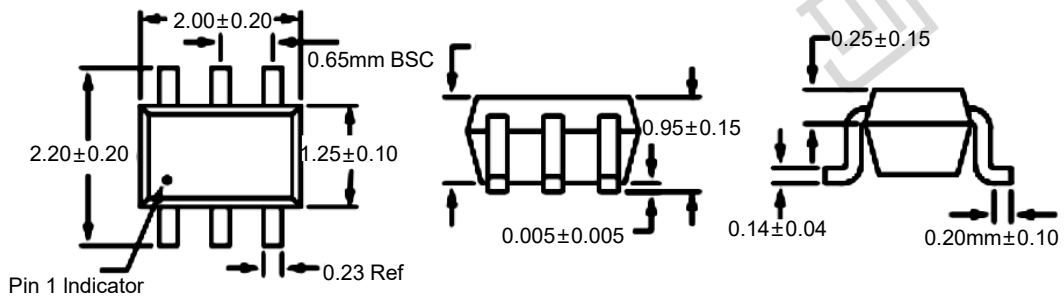

Part Number	Package Type	package	quantity
HXAS179-92LF	SOT-363	Taping	3000

## Disclaimer

All products due to improve reliability, function or design or for other reasons, product specifications and data are subject to change without notice.

Zhuhai Haixin Electronics Co., Ltd., branches, agents, employees, and all persons acting on its or their representatives (collectively, the "zhuhai Haixindianzi"), assumes no responsibility for any errors, inaccuracies or incomplete data contained in the table or any other any disclosure of any information related to the product. ([www.haixindianzi.com](http://www.haixindianzi.com))

Zhuhai Haixin makes no guarantee, representation or warranty on the product for any particular purpose of any goods or continuous production. To the maximum extent permitted by applicable law on Zhuhai Haixin relinquished: (1) any application and all liability arising out of or use of any products; (2) any and all liability, including but not limited to special, consequential damages or incidental ; (3) any and all implied warranties, including a particular purpose, non-infringement and merchantability guarantee.

Statement on certain types of applications are based on knowledge of the product is often used in a typical application of the general product Haixin Zhuhai demand that the Zhuhai Haixin of. Statement on whether the product is suitable for a particular application is non-binding. It is the customer's responsibility to verify specific product features in the products described in the specification is appropriate for use in a particular application. Parameter data sheets and technical specifications can be provided may vary depending on the application and performance over time. All operating parameters, including typical parameters must be made by customer's technical experts validated for each customer application. Product specifications do not expand or modify Zhuhai Haixin purchasing terms and conditions, including but not limited to warranty herein.

Unless expressly stated in writing, Zhuhai Haixin products are not intended for use in medical, life saving, or life sustaining applications or any other application. Wherein Haixin product failure could lead to personal injury or death, use or sale of products used in Zhuhai Haixin such applications using client did not express their own risk. Contact your authorized Zhuhai Haixin people who are related to product design applications and other terms and conditions in writing.

The information provided in this document and the company's products without a license, express or implied, by estoppel or otherwise, to any intellectual property rights granted to the Haixin act or document. Product names and trademarks referred to herein are trademarks of their respective representatives will be all.