

0.1-4.2GHz SPDT Switch for 3G/4G/5G

Features

- Broadband frequency range: 0.1 to 4.2GHz
- Low insertion loss: 0.28dB typical @ 2.7GHz
- High isolation: 30dB @ 2.7GHz
- Integrated logic
- DFN 1.1X0.7-6L package

Applications

- Cellular 3G/4G/5G
- Cellular modems , tablets and USB Devices
- Other RF front-end modules

General Description

The AW13422HDNR is a SPDT switch with low insertion loss and high Isolation. It can be used to support band switching and mode switching for cellular 3G/4G/5G, data cards and tablets.

The symmetrical design of internal ports makes it convenient for PCB routing and adjustment of receiving and transmitting signals. The band/mode switching is realized by the GPIO pins as referenced in the chip block diagram and the control logic.

The AW13422HDNR is provided in a compact DFN 1.1X0.7-6L package.

Typical Application Circuit

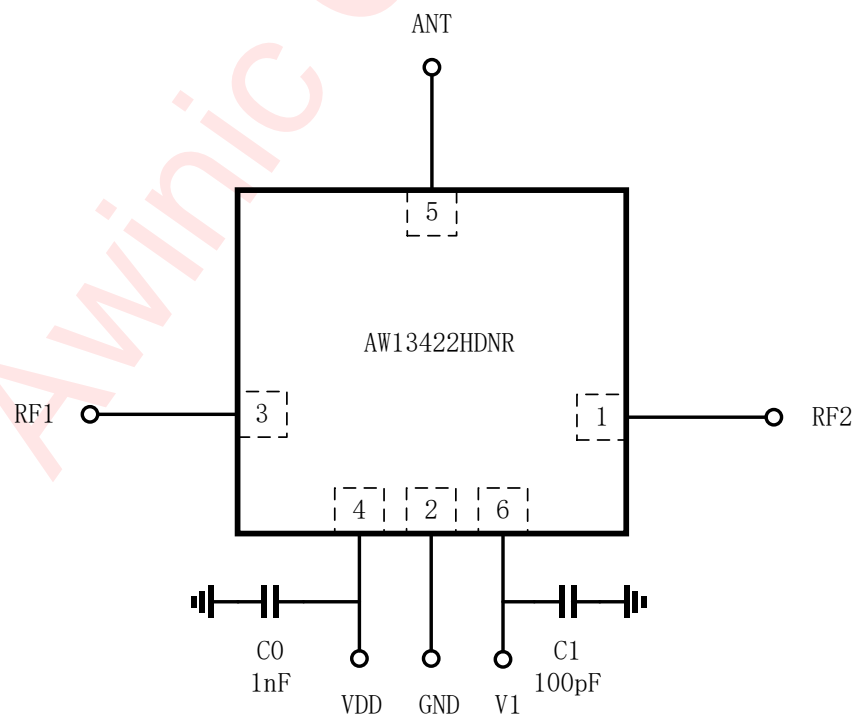

Figure 1 Typical Application Circuit of AW13422HDNR

Pin Configuration And Top Mark

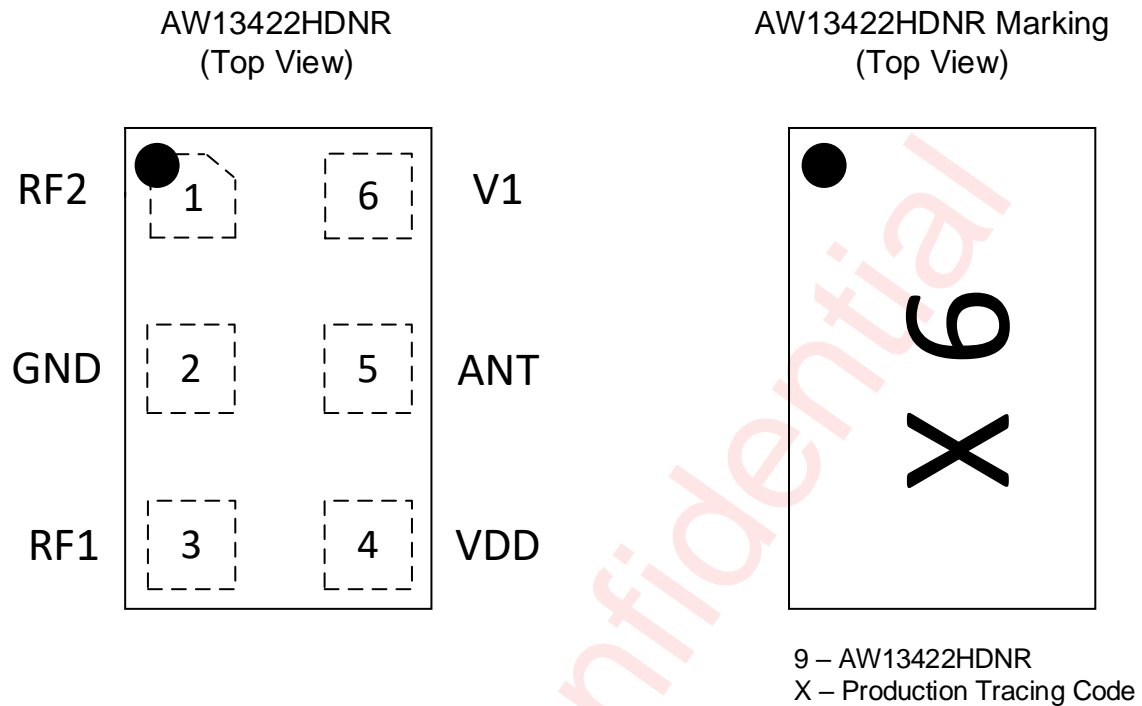

Figure 2 Pin Configuration and Top Mark

Pin Definition

No.	NAME	DESCRIPTION
1	RF2	RF I/O path 2
2	GND	Ground
3	RF1	RF I/O path 1
4	VDD	DC power supply
5	ANT	Antenna port
6	V1	DC control voltage 1

Functional Block Diagram

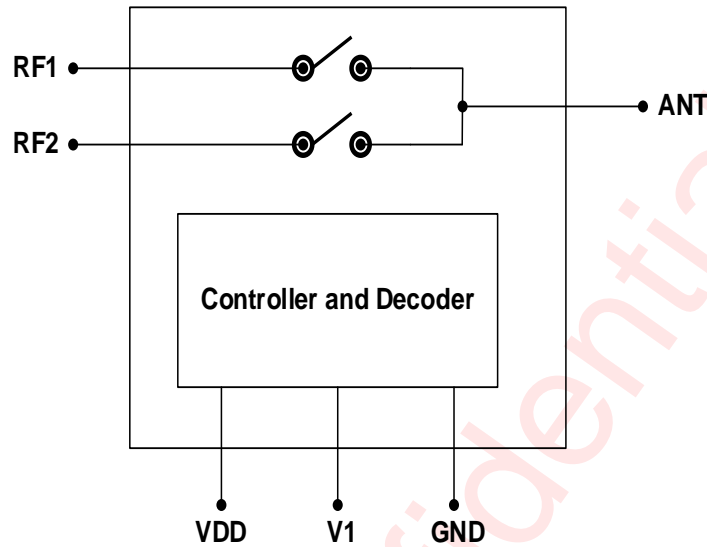

Figure 3 Functional Block Diagram

Ordering Information

Part Number	Temperature	Package	Marking	Moisture Sensitivity Level	Environmental Information	Delivery Form
AW13422HDNR	-40°C~105°C	DFN 1.1X0.7-6L	9	MSL1	ROHS+HF	9000 units/ Tape and Reel

Absolute Maximum Ratings(NOTE1)

PARAMETERS		RANGE
Supply Voltage Range VDD		-0.3V to 3.6V
Control Voltage Range	V1	-0.3V to 3.6V
RF input power(RF1/RF2)		31dBm
Operating Free-air Temperature Range		-40°C to 105°C
Storage Temperature T _{STG}		-65°C to 150°C
Lead Temperature (Soldering 10 Seconds)		260°C
ESD (NOTE 2)		
HBM		±1000V
CDM		±1000V

NOTE1: Conditions out of those ranges listed in "absolute maximum ratings" may cause permanent damages to the device. In spite of the limits above, functional operation conditions of the device should within the ranges listed in "recommended operating conditions". Exposure to absolute-maximum-rated conditions for prolonged periods may affect device reliability.

NOTE2: The human body model is a 100pF capacitor discharged through a 1.5kΩ resistor into each pin.

HBM Test method: ESDA/JEDEC JS-001-2017. CDM Test method: ESDA/JEDEC JS-002-2018.

Electrical Characteristics

VDD=1.8V, V1=0/1.8V, PIN=0dBm, TEMP=+25°C, Z₀=50Ω. (unless otherwise noted)

PARAMETER		TEST CONDITION	MIN	TYP	MAX	UNIT
VDD	Supply Voltage		1.65	1.8	3.3	V
IDD	Supply Current			45	80	μA
VCTL_H VCTL_L	Control Voltage High Low		0.75 0		VDD 0.4	V
ICTL	Control Current	VCTL=1.8V		0.1	1	μA
T _{SW}	Switching On/Off Time	50% of final control voltage to 10%/90% of final RF power, switching between RF1/2		185	300	ns
IL	Insertion loss(ANT pin to RF1/RF2)	0.1-0.96GHz		0.20	0.30	dB
		0.96-2.2GHz		0.23	0.35	dB
		2.3-2.7GHz		0.28	0.45	dB
		3.3-4.2GHz		0.33	0.50	dB
ISO	Isolation (ANT pin to RF1/RF2)	0.1-0.96GHz	32	35		dB
		0.96-2.2GHz	28	31		dB
		2.3-2.7GHz	27	30		dB
		3.3-4.2GHz	26	29		dB
RL	Input return loss (ANT pin to RF1/RF2)	0.1-0.96GHz	30	35		dB
		0.96-2.2GHz	26	29		dB
		2.3-2.7GHz	23	27		dB
		3.3-4.2GHz	20	24		dB
2fo	Second harmonics (ANT pin to RF1/RF2)	PIN=+26dBm, 900MHz		-65	-55	dBm
3fo	Third harmonics (ANT pin to RF1/RF2)	PIN=+26dBm, 900MHz		-70	-60	dBm
2fo	Second harmonics (ANT pin to RF1/RF2)	PIN=+26dBm, 1900MHz		-70	-60	dBm
3fo	Third harmonics (ANT pin to RF1/RF2)	PIN=+26dBm, 1900MHz		-65	-55	dBm
2fo	Second harmonics (ANT pin to RF1/RF2)	PIN=+26dBm, 2400MHz		-75	-65	dBm
3fo	Third harmonics (ANT pin to RF1/RF2)	PIN=+26dBm, 2400MHz		-65	-55	dBm
P _{0.1dB}	0.1dB Compression Point (ANT pin to RF1/RF2)	0.1GHz–4.2GHz 25% DC		31		dBm

Timing Diagram (Power ON and OFF sequence)

It is very important that the user adheres to the correct power-on/off sequence in order to avoid damaging the device. The control signal V1 should be set to 0V unless VDD is set in the operating voltage range.

Power ON:

- 1) Apply voltage supply --- VDD
- 2) Set Controls---V1
- 3) Apply RF input

Change switch position from one RF port to another:

- 1) Remove RF input
- 2) Change control voltages V1 to set the switch to desired RF port
- 3) Apply RF input

Power OFF:

- 1) Remove RF input
- 2) Remove control voltages-V1
- 3) Remove VDD input

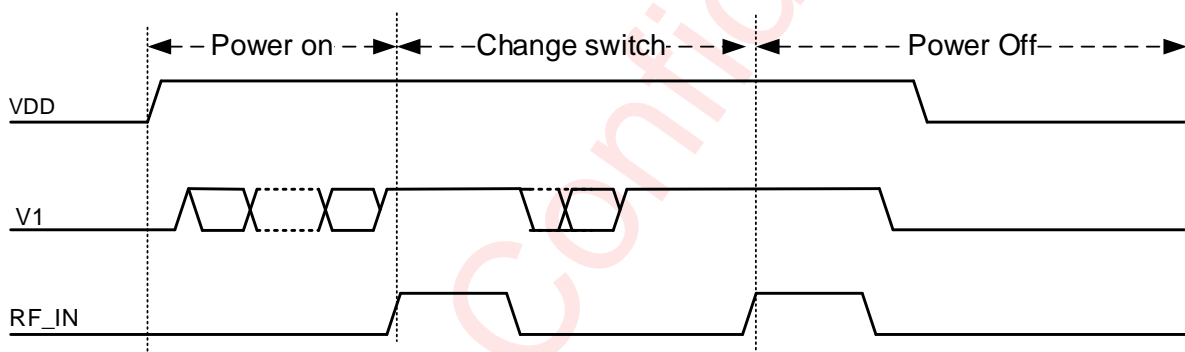
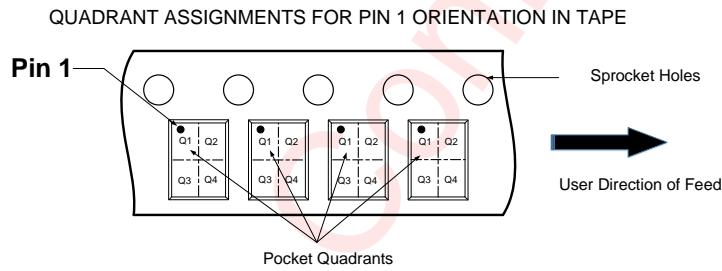
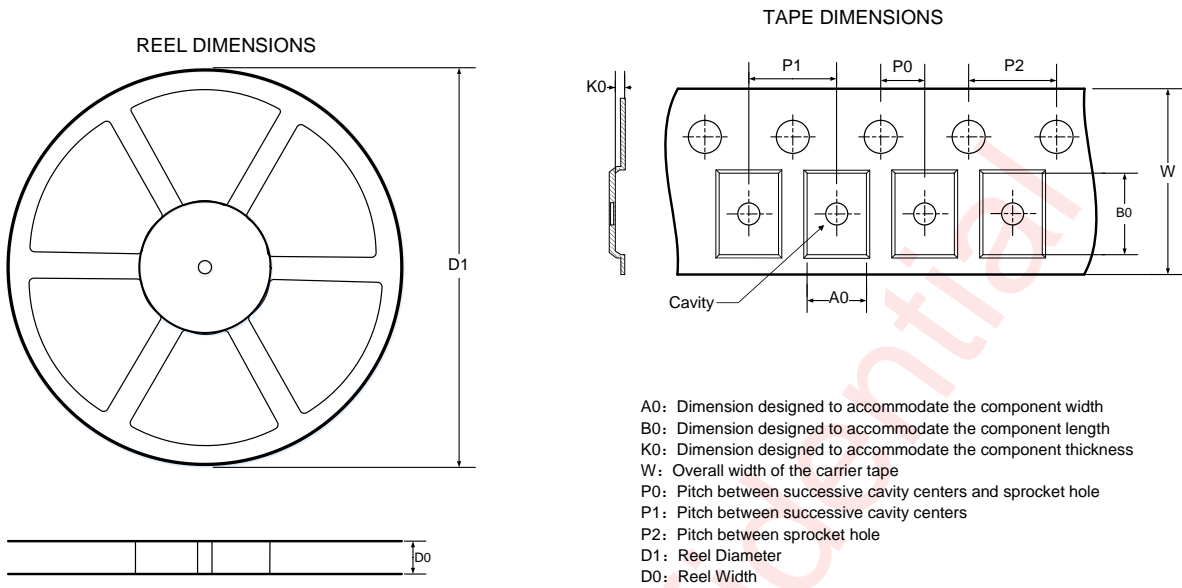

Figure 4 Power on/Change switch/Power off sequence

Control Logic

State	Active Path	V1
0	ANT to RF1	0
1	ANT to RF2	1

Tape and Reel Information



Note: The above picture is for reference only. Please refer to the value in the table below for the actual size

DIMENSIONS AND PIN1 ORIENTATION

D1 (mm)	D0 (mm)	A0 (mm)	B0 (mm)	K0 (mm)	P0 (mm)	P1 (mm)	P2 (mm)	W (mm)	Pin1 Quadrant
178	8.4	0.82	1.22	0.66	2	2	4	8	Q1

All dimensions are nominal

Figure 5 Tape and Reel

Package Description

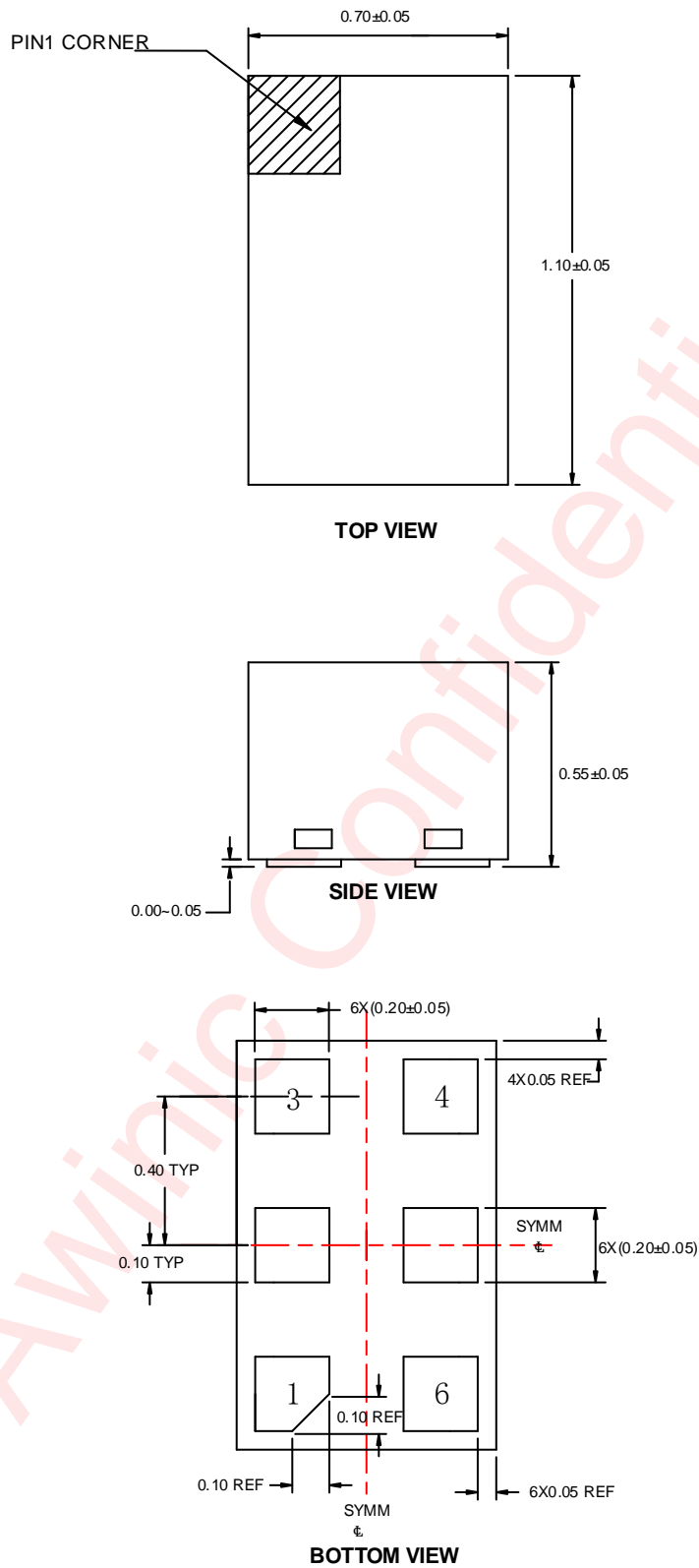

Figure 6 Package Outline

Land Pattern Data

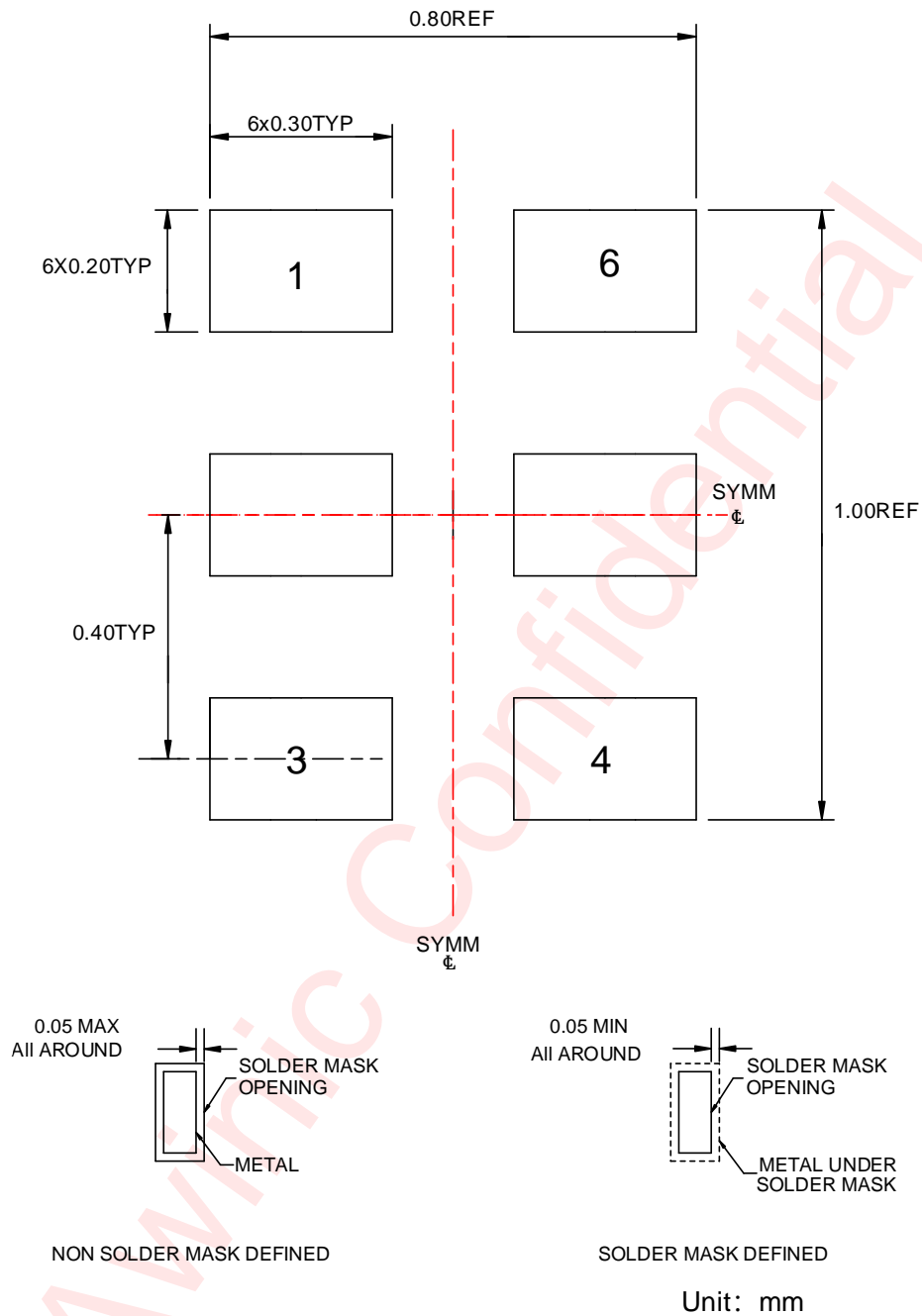

Figure 7 Land Pattern

Revision History

Version	Date	Change Record
V1.0	Aug. 2024	Officially Released

Awinic Confidential

Disclaimer

All trademarks are the property of their respective owners. Information in this document is believed to be accurate and reliable. However, Shanghai Awinic Technology Co., Ltd (Awinic Technology) does not give any representations or warranties, expressed or implied, as to the accuracy or completeness of such information and shall have no liability for the consequences of use of such information.

Awinic Technology reserves the right to make changes to information published in this document, including without limitation specifications and product descriptions, at any time and without notice. Customers shall obtain the latest relevant information before placing orders and shall verify that such information is current and complete. This document supersedes and replaces all information supplied prior to the publication hereof.

Awinic Technology products are not designed, authorized or warranted to be suitable for use in medical, military, aircraft, space or life support equipment, nor in applications where failure or malfunction of an Awinic Technology product can reasonably be expected to result in personal injury, death or severe property or environmental damage. Awinic Technology accepts no liability for inclusion and/or use of Awinic Technology products in such equipment or applications and therefore such inclusion and/or use is at the customer's own risk.

Applications that are described herein for any of these products are for illustrative purposes only. Awinic Technology makes no representation or warranty that such applications will be suitable for the specified use without further testing or modification.

All products are sold subject to the general terms and conditions of commercial sale supplied at the time of order acknowledgement.

Nothing in this document may be interpreted or construed as an offer to sell products that is open for acceptance or the grant, conveyance or implication of any license under any copyrights, patents or other industrial or intellectual property rights.

Reproduction of Awinic information in Awinic data books or data sheets is permissible only if reproduction is without alteration and is accompanied by all associated warranties, conditions, limitations, and notices. Awinic is not responsible or liable for such altered documentation. Information of third parties may be subject to additional restrictions.

Resale of Awinic components or services with statements different from or beyond the parameters stated by Awinic for that component or service voids all express and any implied warranties for the associated Awinic component or service and is an unfair and deceptive business practice. Awinic is not responsible or liable for any such statements.