

## 30V Dual N-Channel MOSFET

### Features

- Low source-source on resistance:
- $R_{SS(ON)}$  Typ.= 7.0mΩ ( $V_{GS}= 10V$ )
- Common-Drain type
- ESD Diode-Protected Gate
- 2kV ESD HBM
- Pb-Free, Halogen Free and RoHS compliance Applications
- WLCSP 3.37mmX1.47mmX0.205mm-10L

### Applications

- Battery protection switch
- Mobile device battery charging and discharging
- USB Type-C/PD

### General Description

$V_{SS}$	$R_{SS(ON)}$ Typ.
30V	7.0 mΩ @ $V_{GS}= 10V$
	10.0 mΩ @ $V_{GS}= 4.5V$

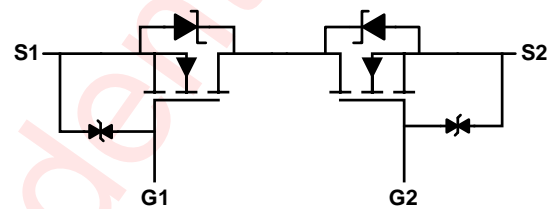

### Pin Configuration and Top Mark

AW403010QCSR  
(Top View)

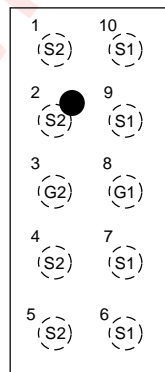

AW403010QCSR Marking  
(Top View)

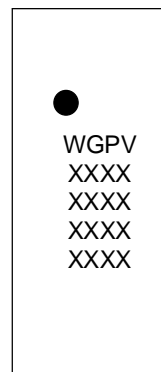

WGPV---AW403010QCSR  
XXXX/XXXX/XXXX/XXXX---Production Tracing Code

## Ordering Information

Part Number	Package	Marking	Moisture Sensitivity Level	Environmental Information	Delivery Form
AW403010QCSR	WLCSP 3.37mmX1.47mm X0.205mm-10L	WGPV	MSL1	RoHS+HF	9000 units/ Tape and Reel

## Absolute Maximum Ratings <sup>(NOTE 1)</sup>

T<sub>A</sub>= 25°C unless otherwise noted

Symbol	Parameter	Maximum	Unit
V <sub>SS</sub>	Source-Source Voltage	30	V
V <sub>GS</sub>	Gate-Source Voltage	±20	V
I <sub>S</sub>	Source Current (DC) <sup>(NOTE 2)</sup>	13	A
I <sub>SM</sub>	Source Current (Pulse) <sup>(NOTE 3)</sup>	72	A
P <sub>D</sub>	Power Dissipation <sup>(NOTE 2)</sup>	2.4	W
T <sub>J</sub>	Operating Junction Temperature	-55 to 150	°C
T <sub>STG</sub>	Storage Temperature	-55 to 150	°C
V <sub>ESD</sub>	Human Body Model <sup>(NOTE 5)</sup>	±2	kV

## Thermal Information

Symbol	Parameter	Condition	Value	Unit
R <sub>θJA</sub>	Maximum Junction to Ambient <sup>(NOTE 2,4)</sup>	Steady-State	52.4	°C/W

NOTE1: Conditions out of those ranges listed in "absolute maximum ratings" may cause permanent damages to the device. In spite of the limits above, functional operation conditions of the device should within the ranges listed in "recommended operating conditions". Exposure to absolute-maximum-rated conditions for prolonged periods may affect device reliability.

NOTE2: Mounted on FR-4 material with 1inch<sup>2</sup>, 2oz. Copper.

NOTE3: PW < 10μs pulses, duty cycle 1% max.

NOTE4: Thermal resistance from junction to ambient is highly dependent on PCB layout.

NOTE5: HBM Standards: ESDA/JEDEC JS-001-2017.

## Electrical Characteristics

T<sub>J</sub>= 25°C for typical values (unless otherwise noted)

Symbol	Parameter	Conditions	Min.	Typ.	Max.	Units
<b>STATIC PARAMETERS</b>						
BV <sub>SSS</sub>	Source - Source Breakdown Voltage	I <sub>S</sub> = 250μA, V <sub>GS</sub> = 0V	30	-	-	V
I <sub>SSS</sub>	Zero Gate Voltage Source Current	V <sub>SS</sub> = 24V, V <sub>GS</sub> = 0V	-	-	1	μA
I <sub>GSS</sub>	Gate Leakage Current	V <sub>SS</sub> = 0V, V <sub>GS</sub> = ±20V	-	-	±10	μA
V <sub>GS(TH)</sub>	Gate Threshold Voltage	V <sub>SS</sub> = V <sub>GS</sub> , I <sub>S</sub> = 250μA	1.3	1.6	2.3	V
R <sub>SS(ON)</sub>	Static Source to Source On-Resistance	V <sub>GS</sub> = 10V, I <sub>S</sub> = 7A	-	7.0	8.5	mΩ
		V <sub>GS</sub> = 4.5V, I <sub>S</sub> = 7A	-	10.0	12.0	mΩ
g <sub>FS</sub>	Forward Transconductance	V <sub>SS</sub> =3V, I <sub>S</sub> = 7A	-	24	-	S
V <sub>FSS</sub>	Forward Source to Source Voltage	I <sub>S</sub> = 7A, V <sub>GS</sub> = 0V	-	0.8	-	V
<b>DYNAMIC PARAMETERS</b>						
R <sub>g</sub>	Series Gate Resistance	f= 1MHz	-	650	-	Ω
C <sub>iss</sub>	Input Capacitance	V <sub>GS</sub> = 0V, V <sub>SS</sub> = 15V, f= 1MHz	-	840	-	pF
C <sub>oss</sub>	Output Capacitance		-	177	-	pF
C <sub>rss</sub>	Reverse Transfer Capacitance		-	48	-	pF
<b>SWITCHING PARAMETERS</b>						
Q <sub>g</sub>	Total Gate Charge	V <sub>GS</sub> = 10V, V <sub>SS</sub> = 15V, I <sub>S</sub> = 7A	-	33.4	-	nC
Q <sub>gs</sub>	Gate Source Charge		-	4.8	-	nC
Q <sub>gd</sub>	Gate Drain Charge		-	6.9	-	nC
Q <sub>g(th)</sub>	Gate Charge at V <sub>GS(TH)</sub>		-	2.7	-	nC
t <sub>d(on)</sub>	Turn - On Delay Time	V <sub>GS</sub> = 10V, V <sub>SS</sub> = 15V, R <sub>L</sub> = 2.1Ω, I <sub>S</sub> = 7A	-	255	-	ns
t <sub>r</sub>	Turn - On Rise Time		-	587	-	ns
t <sub>d(off)</sub>	Turn - Off Delay Time		-	2886	-	ns
t <sub>f</sub>	Turn - Off Fall Time		-	1864	-	ns

## Typical Electrical and Thermal Characteristics

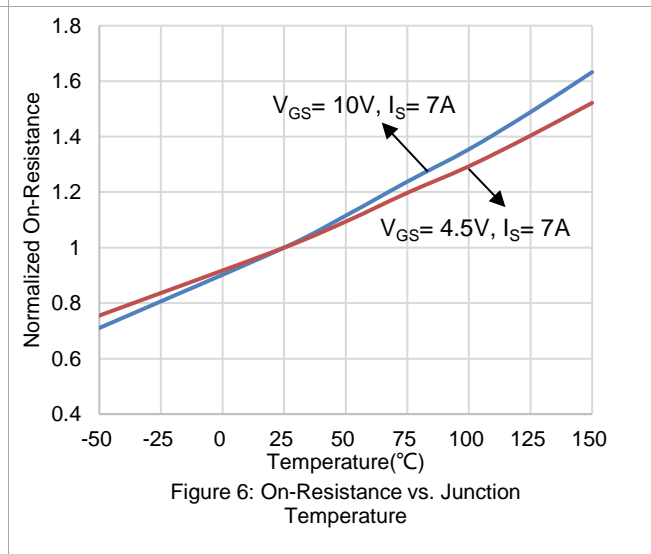
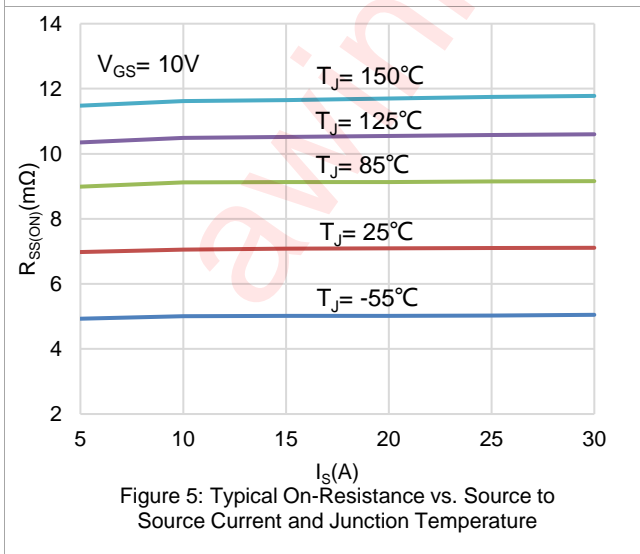
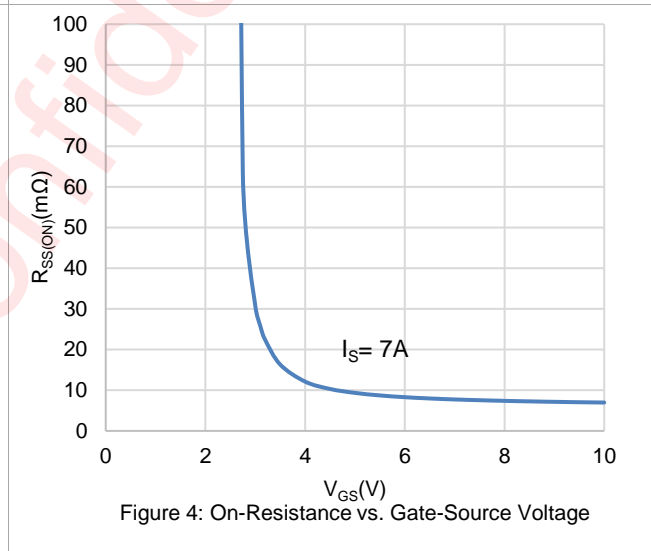
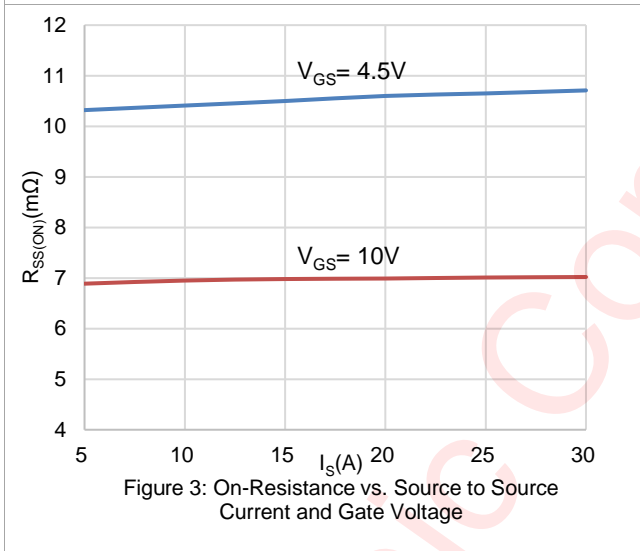
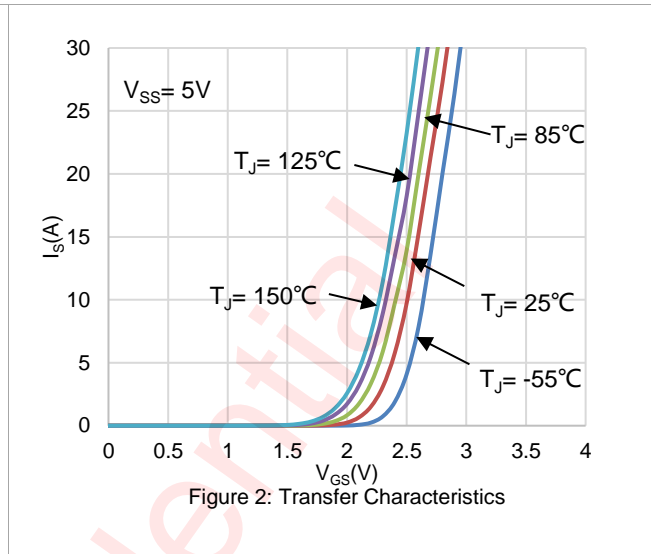
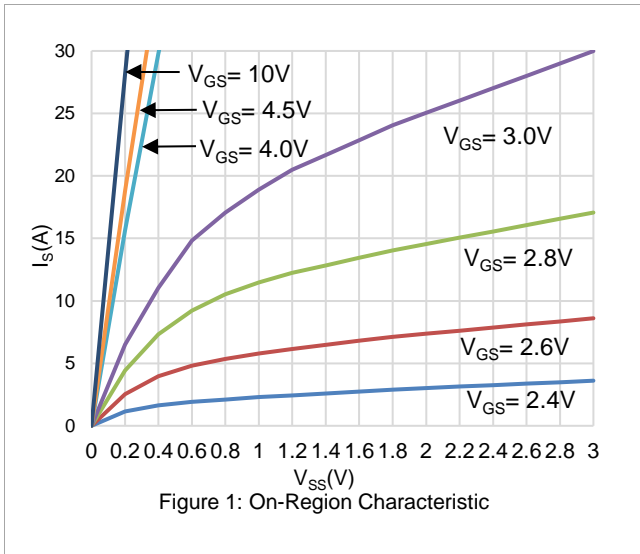

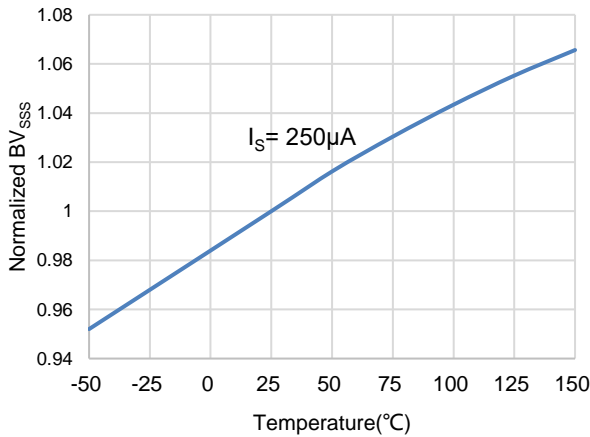

Figure 7: Source to Source Breakdown Voltage vs. Junction Temperature

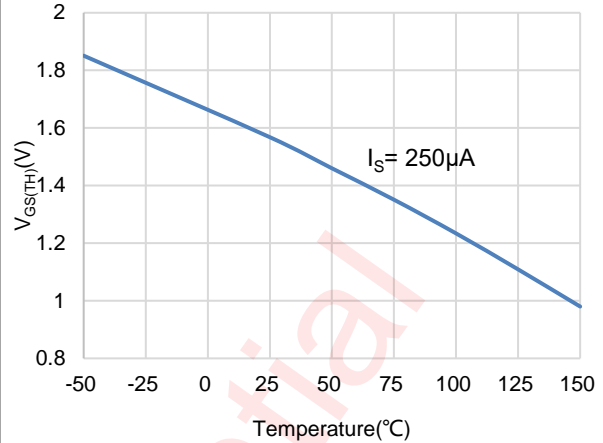

Figure 8: Gate Threshold Variation vs. Junction Temperature

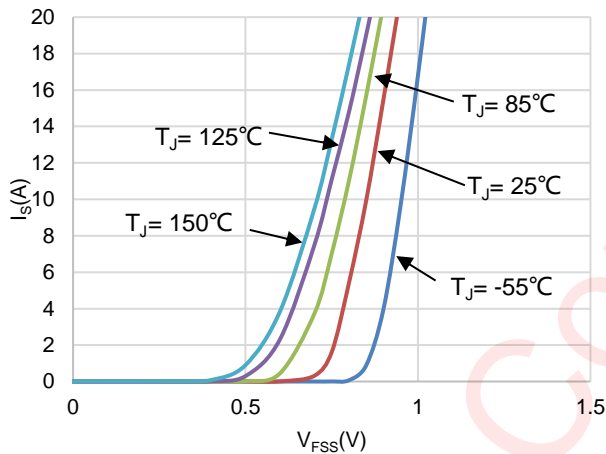

Figure 9: Diode Forward Voltage vs. Current and Junction Temperature

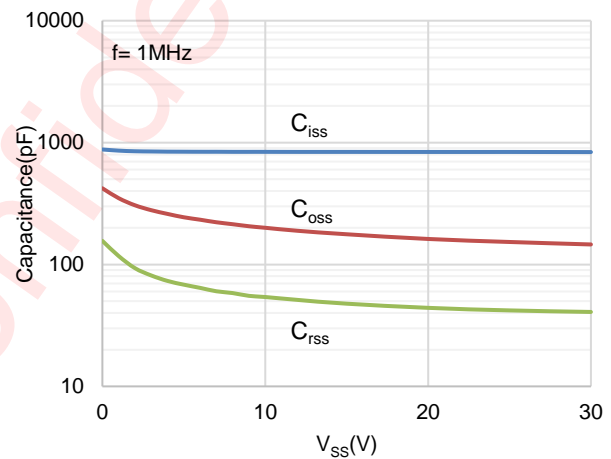

Figure 10: Typical Junction Capacitance

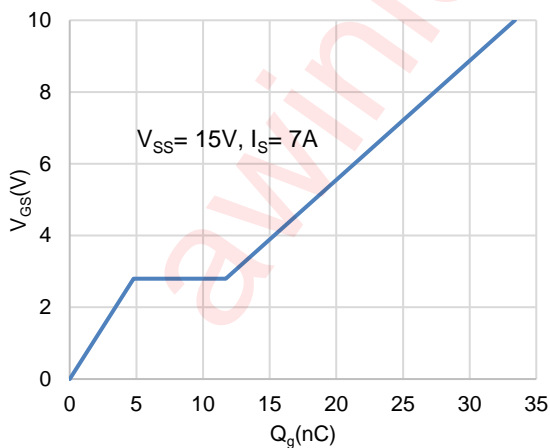

Figure 11: Gate Charge

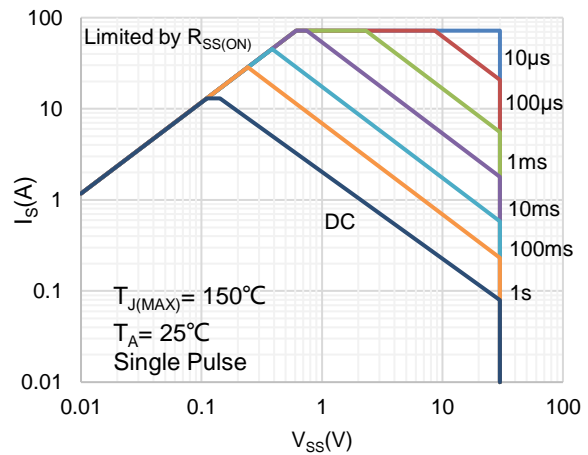
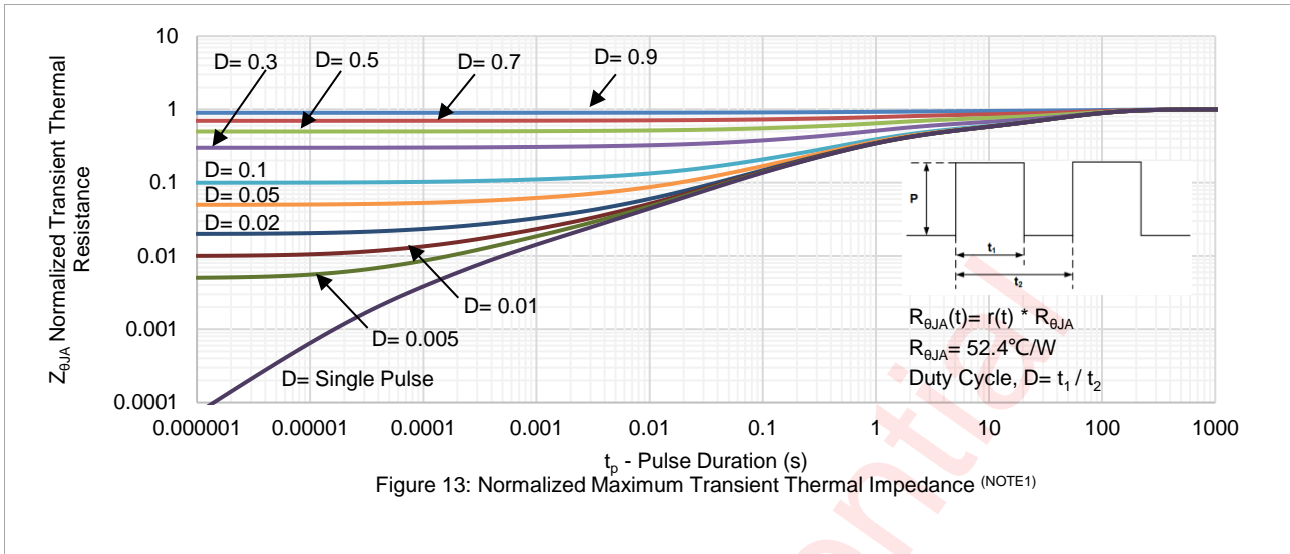
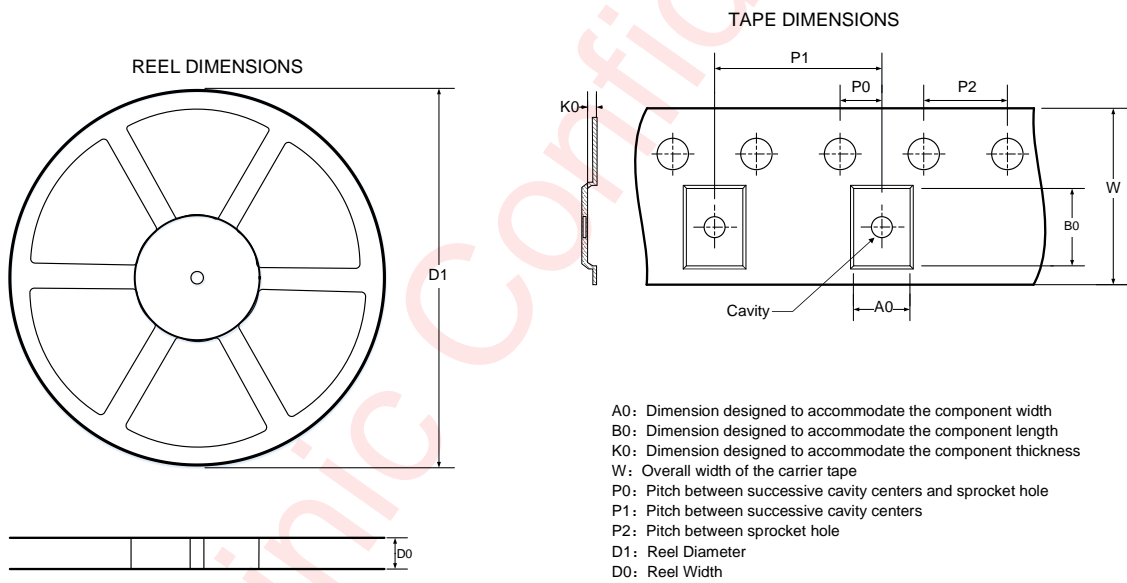

Figure 12: Maximum Safe Operating Area



### Tape And Reel Information



#### QUADRANT ASSIGNMENTS FOR PIN 1 ORIENTATION IN TAPE

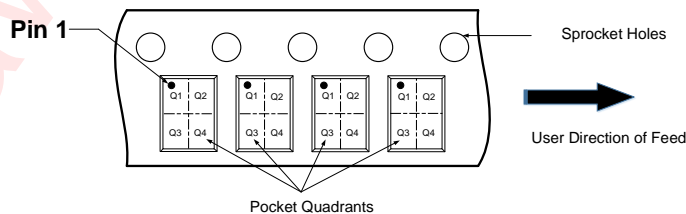

Note: The above picture is for reference only. Please refer to the value in the table below for the actual size

#### DIMENSIONS AND PIN1 ORIENTATION

D1 (mm)	D0 (mm)	A0 (mm)	B0 (mm)	K0 (mm)	P0 (mm)	P1 (mm)	P2 (mm)	W (mm)	Pin1 Quadrant
330	12.4	1.78	3.59	0.54	2	8	4	12	Q1

All dimensions are nominal

Package Description

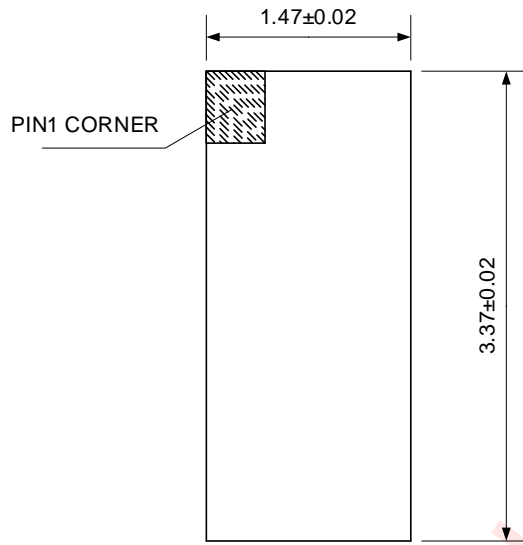

Top View



Side View

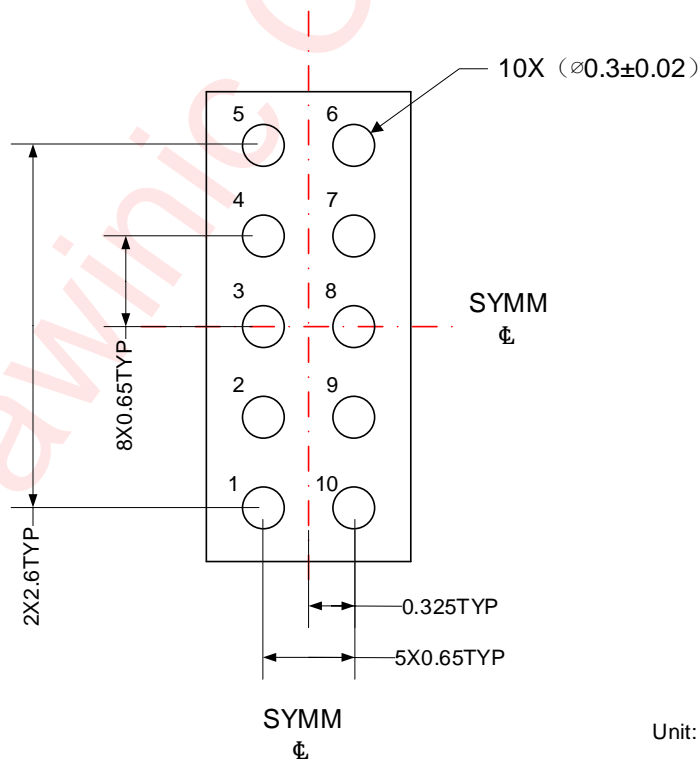

Bottom View

Unit: mm

Land Pattern Data

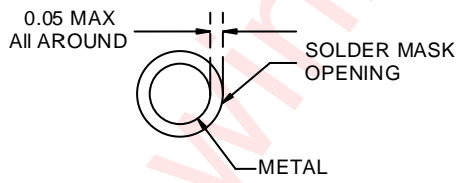
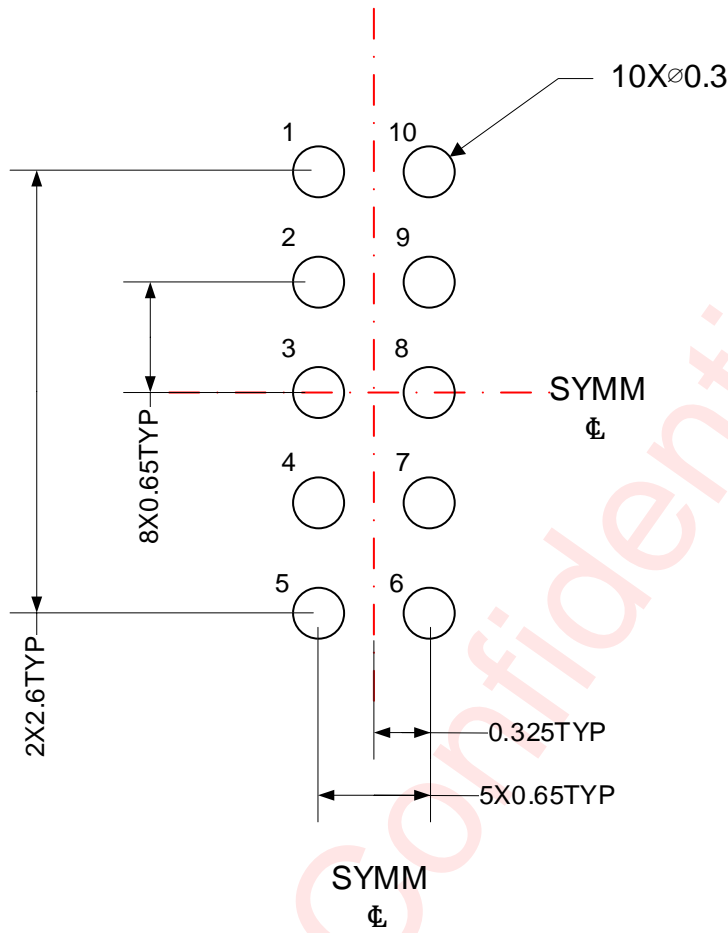

NON SOLDER MASK DEFINED

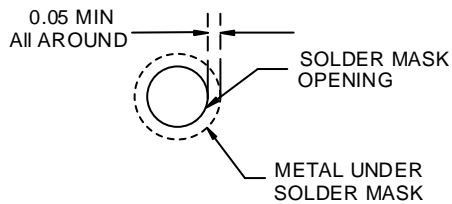

SOLDER MASK DEFINED

Unit: mm

## Revision History

Version	Date	Change Record
V1.0	Feb. 2023	Officially released
V1.1	Feb. 2023	Updated the value of A0/B0/K0 in Tape And Reel Information. (P6)
V1.2	Mar. 2023	Updated the value of V <sub>ss</sub> in Switching Parameters Condition. (P3)
V1.3	May. 2023	Updated Tape And Reel Information. (P6)

awinic Confidential

## Disclaimer

All trademarks are the property of their respective owners. Information in this document is believed to be accurate and reliable. However, Shanghai AWINIC Technology Co., Ltd (AWINIC Technology) does not give any representations or warranties, expressed or implied, as to the accuracy or completeness of such information and shall have no liability for the consequences of use of such information.

AWINIC Technology reserves the right to make changes to information published in this document, including without limitation specifications and product descriptions, at any time and without notice. Customers shall obtain the latest relevant information before placing orders and shall verify that such information is current and complete. This document supersedes and replaces all information supplied prior to the publication hereof.

AWINIC Technology products are not designed, authorized or warranted to be suitable for use in medical, military, aircraft, space or life support equipment, nor in applications where failure or malfunction of an AWINIC Technology product can reasonably be expected to result in personal injury, death or severe property or environmental damage. AWINIC Technology accepts no liability for inclusion and/or use of AWINIC Technology products in such equipment or applications and therefore such inclusion and/or use is at the customer's own risk.

Applications that are described herein for any of these products are for illustrative purposes only. AWINIC Technology makes no representation or warranty that such applications will be suitable for the specified use without further testing or modification.

All products are sold subject to the general terms and conditions of commercial sale supplied at the time of order acknowledgement.

Nothing in this document may be interpreted or construed as an offer to sell products that is open for acceptance or the grant, conveyance or implication of any license under any copyrights, patents or other industrial or intellectual property rights.

Reproduction of AWINIC information in AWINIC data books or data sheets is permissible only if reproduction is without alteration and is accompanied by all associated warranties, conditions, limitations, and notices. AWINIC is not responsible or liable for such altered documentation. Information of third parties may be subject to additional restrictions.

Resale of AWINIC components or services with statements different from or beyond the parameters stated by AWINIC for that component or service voids all express and any implied warranties for the associated AWINIC component or service and is an unfair and deceptive business practice. AWINIC is not responsible or liable for any such statements.