

RIGHT ANGLE PLUG SOLDER TYPE

R223.162.000

CABLE .085

Series : MMBX

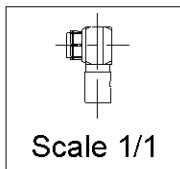
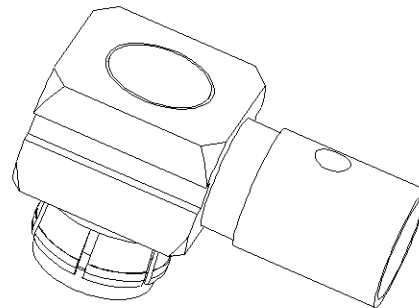
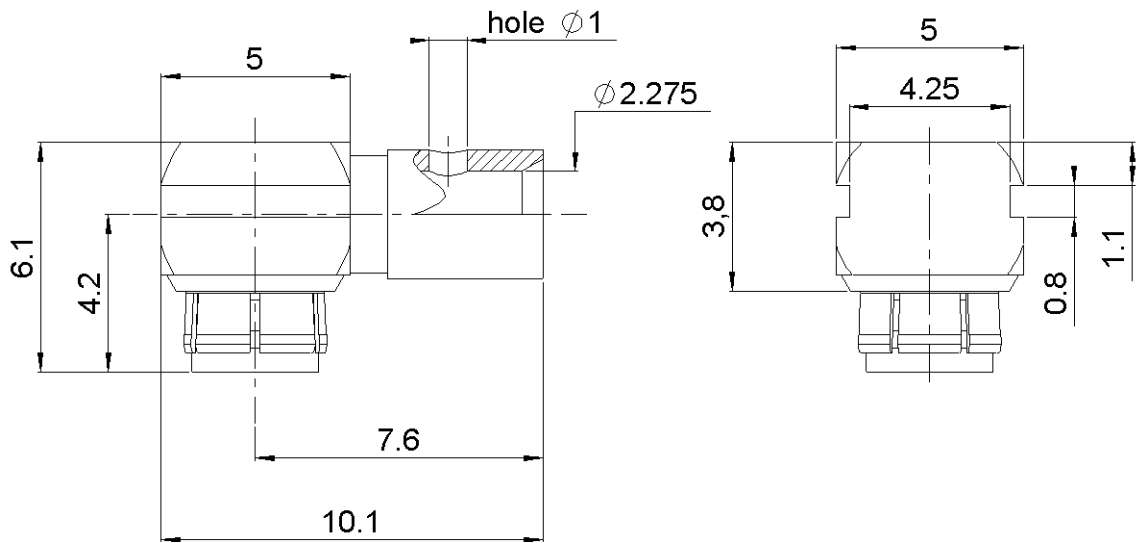

All dimensions are in mm.

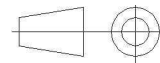

COMPONENTS	MATERIALS	PLATING (µm)
BODY	BRASS	NPGR
CENTER CONTACT	BERYLLIUM COPPER	NPGR
OUTER CONTACT	BERYLLIUM COPPER	NPGR
INSULATOR	PTFE	
GASKET		
OTHERS PARTS	BRASS	NPGR
-	-	-
-	-	-

Issue : 0736 B

In the effort to improve our products, we reserve the right to make changes judged to be necessary.



RIGHT ANGLE PLUG SOLDER TYPE

R223.162.000

CABLE .085

Series : MMBX

PACKAGING

Standard	Unit	Other
100	'W' option	Contact us

SPECIFICATION

ELECTRICAL CHARACTERISTICS

Impedance		50 Ω
Frequency		0-12.4 GHz
VSWR	1.20 +	0,0000 x F(GHz) Maxi
Insertion loss		0.05 √F(GHz) dB Maxi
RF leakage	- (100 - F(GHz)) dB Maxi
Voltage rating		250 Veff Maxi
Dielectric withstanding voltage		750 Veff mini
Insulation resistance		1000 MΩ mini

CABLE ASSEMBLY

Stripping	a	b	c	d	e	f
mm	2,60	1,40	0,00	0,00	0,00	0,00

Assembly instruction :

Recommended cable(s)
RG 405

-
Characteristics indicated on this data sheet are those that can be achieved with the highest performance cable. Intrinsic limitations of the cable may diminish the performance of the assembly

Cable retention

- pull off **136** N mini
- torque **NA** N.cm

MECHANICAL CHARACTERISTICS

Center contact retention		
Axial force – Mating end	10	N mini
Axial force – Opposite end	10	N mini
Torque	NA	N.cm mini

TOOLING

Part Number	Description	Hexagon
.	.	.
R282.868.000	EXTRACTION ASSEMBLY TOOL	

Recommended torque		
Mating	NA	N.cm
Panel nut	NA	N.cm
Clamp nut	NA	N.cm
A/F clamp nut	0,0000	mm

OTHER CHARACTERISTICS

to 6 GHz
Interface MMBX only up to 2.5GHz

ENVIRONMENTAL

Operating temperature	-55/+155	° C
Hermetic seal	NA	Atm.cm3/s
Panel leakage	NA	

Issue : 0736 B

In the effort to improve our products, we reserve the right to make changes judged to be necessary.



RIGHT ANGLE PLUG SOLDER TYPE

R223.162.000

CABLE .085

Series : MMBX

COMPONENTS

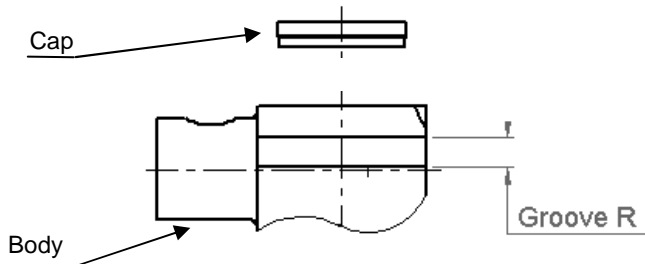

STRIPPING DIMENSIONS

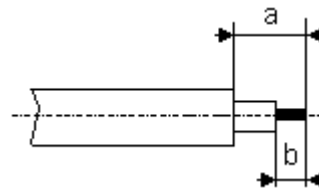

We recommend a thermal preconditioning cable.

1

Strip the cable.
To tin cable inner conductor.



3

Press fit the cap.

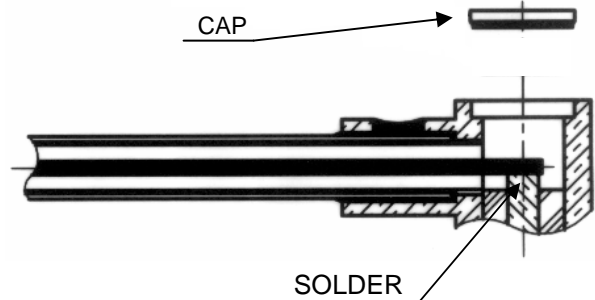

2

To push the cable into the connector body until contact with it.
To solder the cable on the connector body.
To solder cable inner conductor into the centre contact.
To clean soldering area.

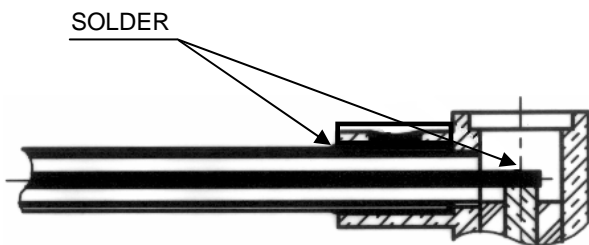

4

Slide mounting tool R282 868 onto the body grooves.
Press fit the cap turning tool handle with adapted wrench 7mm (cap in the same face).

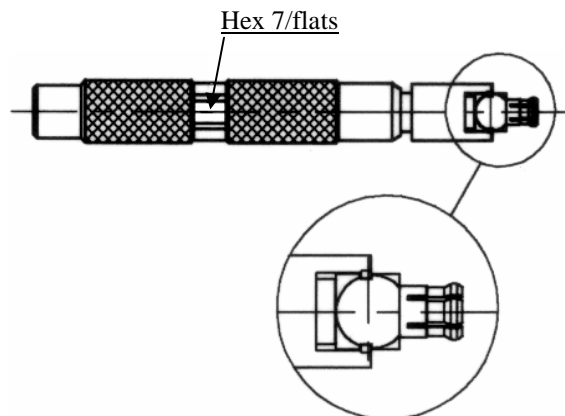

Issue : 0736 B

In the effort to improve our products, we reserve the right to make changes judged to be necessary.

