

**可控硅光耦**  
**Thyristor optocoupler**

**ATM30VX**

**Product Data Sheet**

**AOTE DCC**  
**RELEASE**

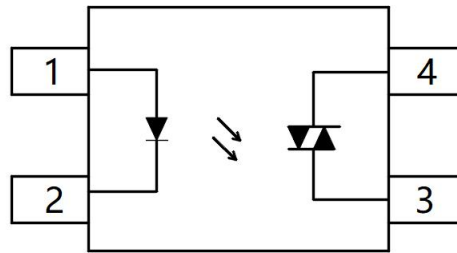
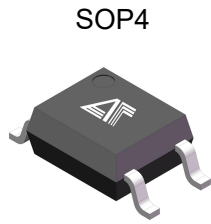

Pin Configuration  
 1. Anode  
 2. Cathode  
 3. Terminal  
 4. Terminal

### ◆ 封装逻辑原理图 Encapsulation logic schematic

ATM301X, ATM302X, ATM305X, ATM307X 系列光耦采用高效光电转换技术，结合先进封装工艺，提供输入输出间的可靠隔离，支持 SOP4 封装形式，适配多样化场景需求。

The ATM301X, ATM302X, ATM305X, ATM307X series optocoupler adopts high-efficiency photoelectric conversion technology and advanced packaging processes, providing reliable input-output isolation. It supports package types (SOP4) to meet diverse application requirements.

### ◆ 产品特征 Product features

- 输入-输出隔离电压  $V_{ios}=3750V_{rms}$   
Input output isolation voltage:  $V_{ios}=3750 V_{rms}$
- 断态输出端电压  $V_{DRM}=800,600,400,250$ ; Off-state output terminal voltage  $V_{DRM}=800,600,400,250$ ;
- 峰值重复浪涌电流  $I_{TSM}=1A$ ; Peak repetitive surge current  $I_{TSM}=1A$
- 爬电距离  $>7.0mm$ ; Creepage distance  $>7.0mm$ ;
- 输入-输出绝缘距离  $>0.4mm$ ; Input-Output insulation Thickness  $>0.4mm$
- 防潮等级 class1; MSL class1
- 产品符合 ROHS、REACH 及 HF 等环保法规要求;  
The products comply with ROHS, REACH and HF;

### ◆ 应用领域 Applications

- 工业自动化与控制 Industrial Automation and Control;  
PLC与变频器, 伺服驱动系统, 工业机器人 PLC and frequency converter, servo drive system, industrial robot 过零型产品用于交流调压 Zero crossing products are used for AC voltage regulation
- 家用电器与消费电子: Household appliances and consumer electronics 电机正反转、加热控制、调速等 Motor forward and reverse heating control, speed regulation, etc 智能照明系统中用于调光控制 Used for dimming control in lighting systems
- 电力系统与能源管理: Power System and Energy Management 用于整流、变压器保护和电网监测 Used for rectification, transformer protection, and power grid monitoring 应用于不间断电源 (UPS) 和电源保护设备 Applied to uninterruptible power supply (UPS) and power protection equipment
- 医疗与特殊场景: Medical and Special Scenarios 用于心率监测仪、X光机等设备隔离与电路保护 Used for isolation and circuit protection of devices such as heart rate monitors and X-ray machines



**◆ 极限参数 Absolute Maximum Ratings (Ta = 25°C)**

参数 Parameter		符号 Symbol	额定值 Rating	单位 Unit	
发射端 Input	正向电流 Forward Current	IF	60	mA	
	反向电压 Backward Voltage	VR	6	V	
	功耗 Power Dissipation	PD	70	mW	
	额定值降低因子(在 Ta = 90°C 以上) Power dissipation Derating factor (above Ta = 90°C)	PDD	3.8	mW/°C	
接收端 Output	断态输出端电压 Off-state output terminal voltage	ATM301X	250	V	
		ATM302X	400		
		ATM305X	600		
		ATM307X	800		
	峰值重复浪涌电流 (pw=100 μs, 120pps) Peak repetitive surge current (pw=100μs, 120pps)		ITSM	1	A
	开启态电流 (均方根值) On-state current (root mean square value)		IT(RMS)	100	mA
	功耗 Power Dissipation		PC	300	mW
	额定值降低因子(在 Ta = 85°C 以上) Power dissipation Derating factor (above Ta = 90°C)			7.4	mW/°C
隔离电压 Isolation Voltage		Viso	3750	Vrms	
工作温度 Operating Temperature		Topr	-55 ~ +110	°C	
存储温度 Storage Temperature		Tstg	-55 ~ +125	°C	
焊接温度 Soldering Temperature		Tsol	260	°C	

**◆ 推荐操作条件 Recommended Operating Conditions**

参数 Parameter	符号 Symbd	最小值 Min	最大值 Max	单位 unit
正向电流 Forward Current	IF	5	15	mA
峰值重复浪涌电流 (pw=100 μs, 120pps) Peak repetitive surge current (pw=100μs, 120pps)	ITSM	-	1	A
开启态电流 (均方根值) On-state current (root mean square value)	IT(RMS)	-	100	mA

## ◆ 产品特性参数 Product characteristic parameters (Ta = 25°C)

参数 Parameter		符号 Symbol	条件 Condition	最小 Min.	典型 Typ.	最大 Max.	单位 Unit	
发射端 Input	正向电压 Forward Voltage	VF	IF=20mA	-	1.23	1.5	V	
	反向电流 Back current	IR	VR=6V	-	-	10	uA	
接收端 Output	断态峰值电流 Off-state peak current	IDRM	VDRM=Rated VDRM IF= 0mA	-	-	100	nA	
	通态峰值电压 On-state peak voltage	VTM	ITM=100mA peak IF=Rated IFT	-	-	2.5	V	
	断态电压临界上升率 Critical rise rate of off-state voltage	ATM301X	dv/dt	VPEAK=Rated VDRM IF=0	-	100	-	V/μs
		ATM302X						
ATM305X		VPEAK=400V, IF =0		1000	-	-		
ATM307X								
传输特性 Transfer Characteristics	LED 触发电流 LED trigger current	ATM3020	主端电压 Main terminal Voltage =3V	-	-	30	mA	
		ATM3011		-	-	15		
		ATM3021						
		ATM3051		-	-	10		
		ATM3071						
		ATM3012						
		ATM3022						
		ATM3052		-	-	5		
		ATM3072						
		ATM3013						
		ATM3023		-	-	5		
		ATM3053						
	ATM3073							
维持电流 Maintain current	IH	-	-	250	-	uA		

◆ **电性特性曲线 Electrical characteristic curve (Ta = 25°C)**

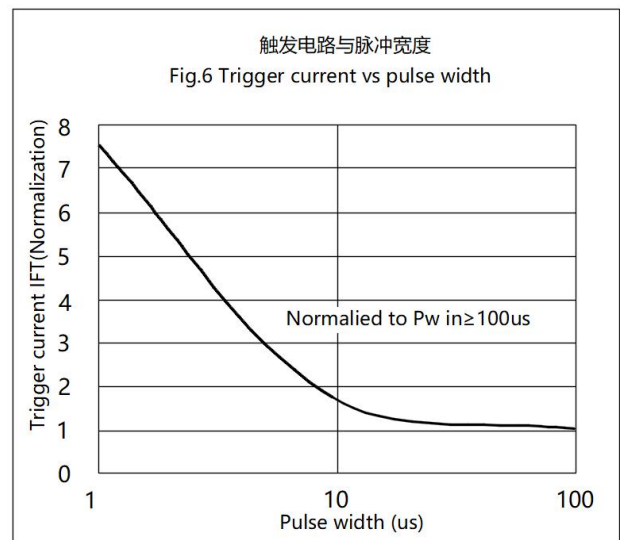
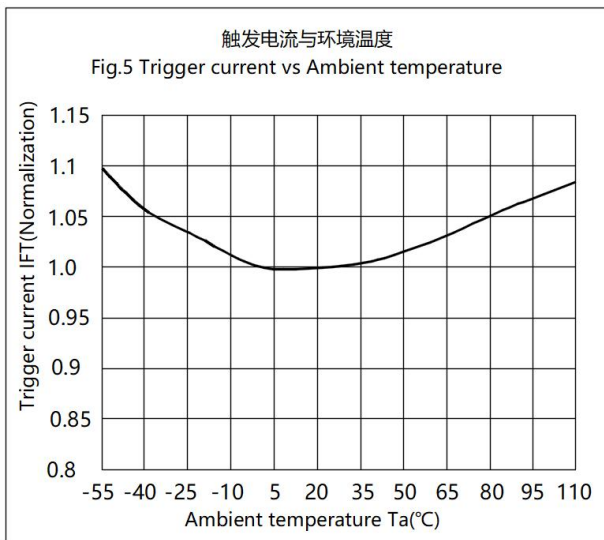
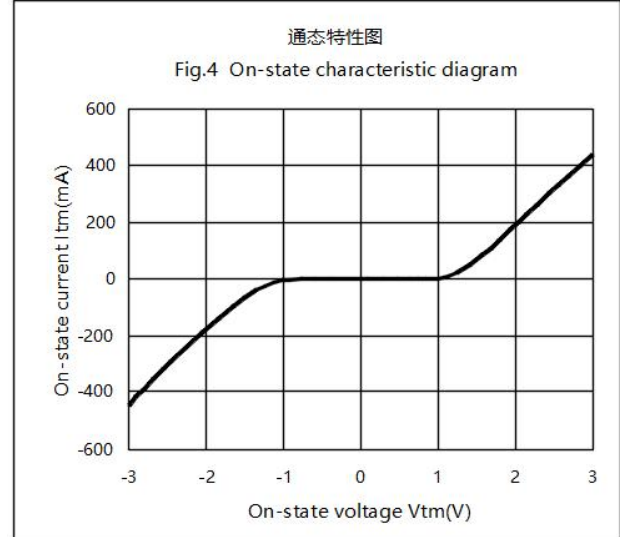
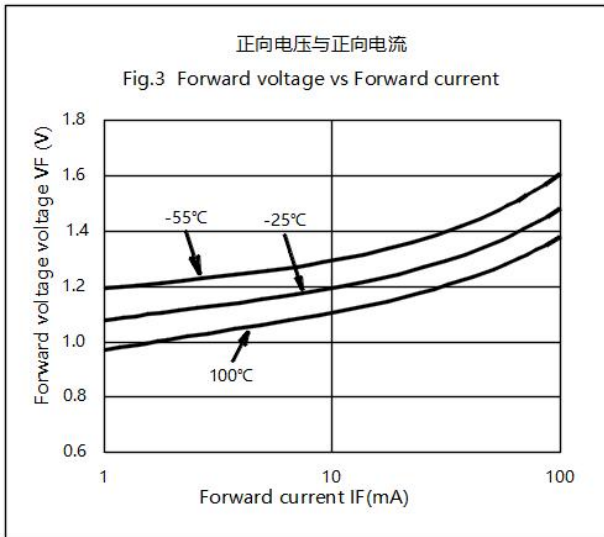
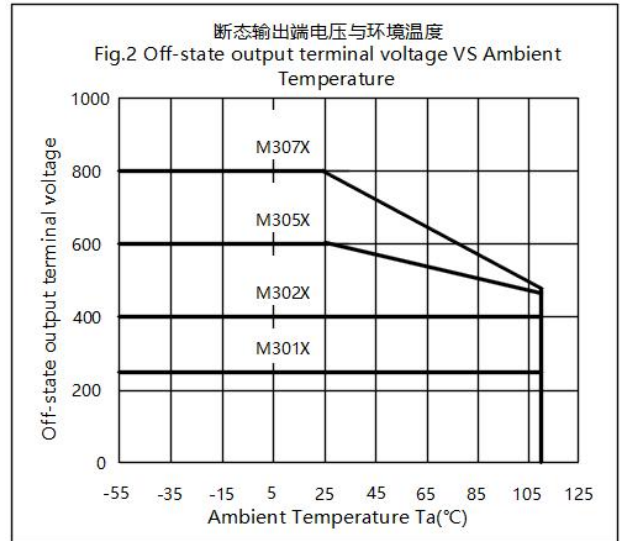
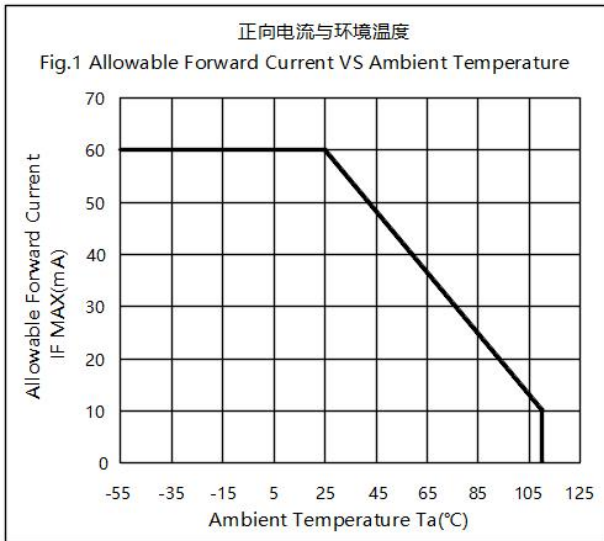

◆ **电性特性曲线 Electrical characteristic curve (Ta = 25°C)**

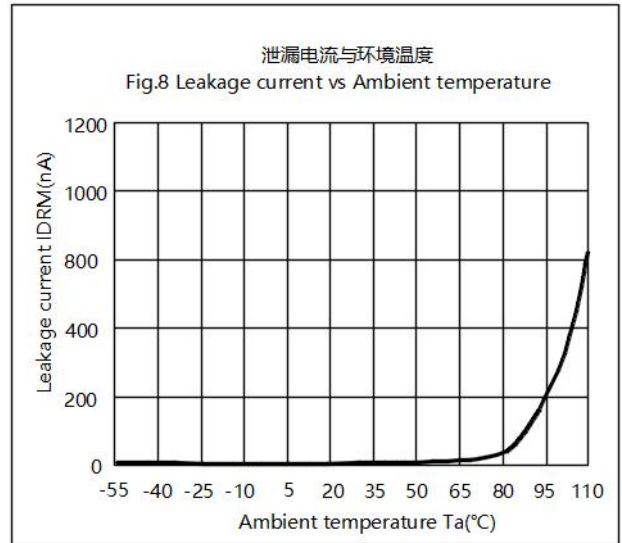
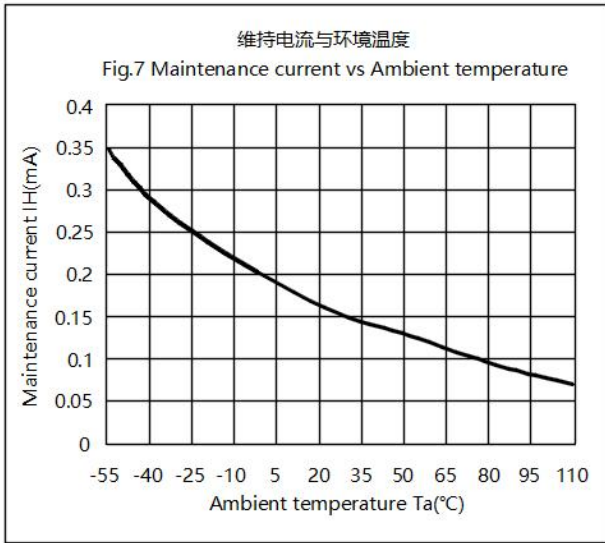

◆ 静态 dv/dt 测试电路和波形 Static dv/dt test circuit and waveform

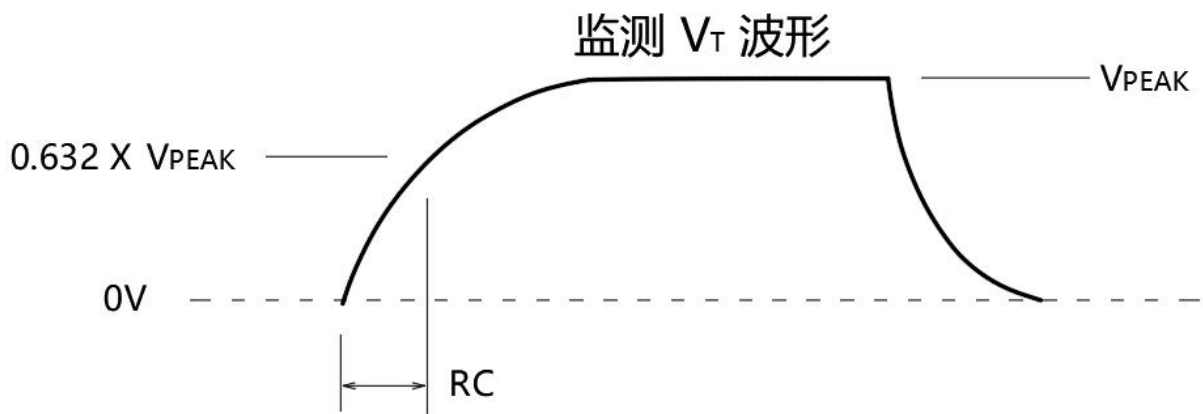
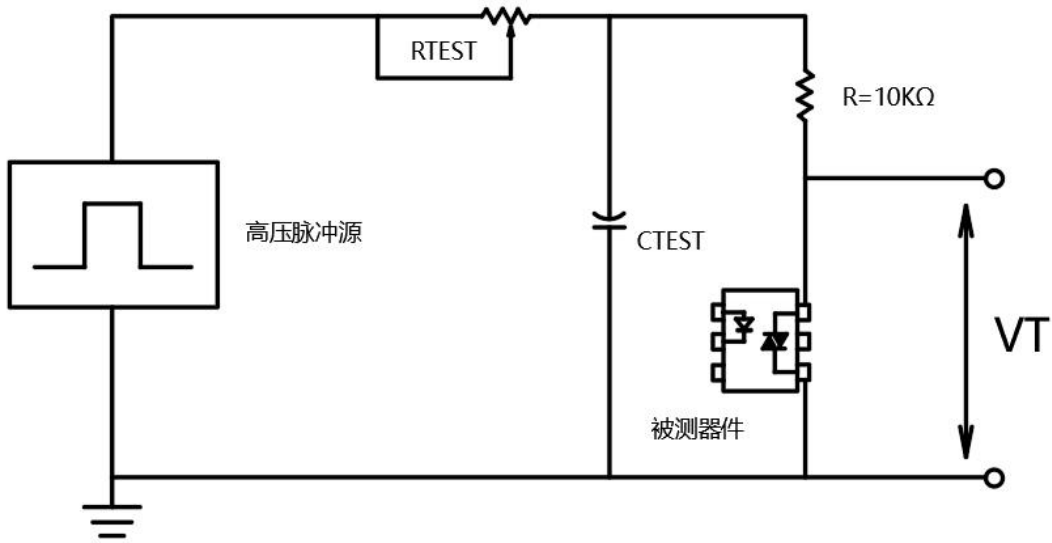

◆ **外形尺寸Overall dimension**

SOP4

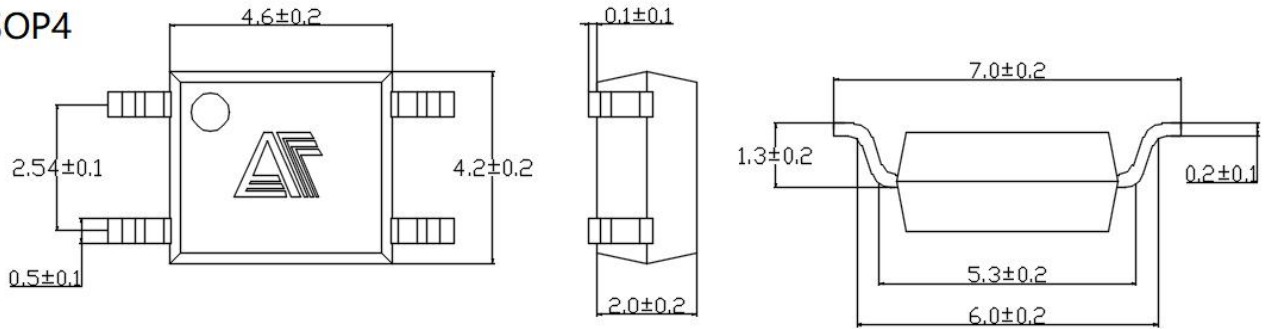

推荐焊盘:

Recommended

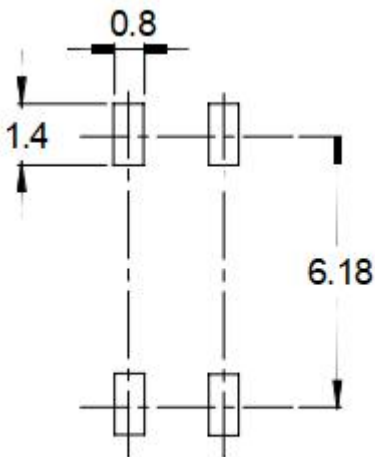



单位: mm

## ◆ 产品型号命名规则 Order Code

### AT M30VX - UN Y - W (V) (ZZ)

- ① 公司代码 Company Code (AT: 奥特 Aote)
- ② 产品系列 Product Series (30VX: ATM301X, ATM302X, ATM305X, ATM307X)
- ③ 框架类型 Lead Frame (Cu: 铜框架 Copper)
- ④ 树脂类型 Epoxy Type (H: 无卤 Halogen-free)
- ⑤ 封装形式 Package (D: DIP, S: SMD)
- ⑥ 器件工作温度范围 Device Operating Temperature Range (特殊范围需填或者空白 Special Range need to be filled in or left blank)
- ⑦ 内部补充代码 Internal Supplementary Code (数字或者空白 Number or None)

## ◆ 印字信息 Marking Information

- 印字中 “” 为奥特品牌LOGO  
“” denotes LOGO
- 印字中 “Y” 代表年份; A(2018), B(2019), C(2020) ... ..  
“Y” denotes YEAR: A(2018), B(2019), C(2020) ... ..
- 印字中 “WW” 代表周号  
“WW” denotes Week' s number
- 印字中 “E” 代表内部代码  
“E” denotes Internal code
- 印字中的 “H” 代表无卤  
“H” denotes Halogen-free



## ◆ 包装packing

封装形式	包装方式	盘数量	盒数量	箱数量	静电袋规格	盒规格	箱(双瓦楞)规格	备注
SOP4	卷盘 ( $\phi 330\text{mm}$ 蓝盘)	3000 只/盘	2 盘/盒	10 盒/箱	450*390*0.1mm	34*6*34cm	62*36*36.5cm	首尾端空至少 200mm
Package Type	Packing Form	Quantity per Reel	Quantity per Box	Quantity per Carton	Antistatic Bag Specification	Box Specification	Carton Specification	Note
SOP4	Reel ( $\phi 330\text{mm}$ Blue)	3000 pcs /reel	2 reels /box	10 boxes /ctn	450*390*0.1mm	34*6*34cm	62*36*36.5cm	Leave at least 200mm of blank space at both ends

## • 编带包装 Tape & Reel

- 1) 每卷数量: 3000 只; Qty/reel: 3000 pcs;
- 2) 每箱数量: 60000 只; Qty/ctn: 60000 pcs;
- 3) 内包装: 每盒 2 盘; Inner packing: 2 reels/box;
- 4) 示意图 Schematic:

### SOP4

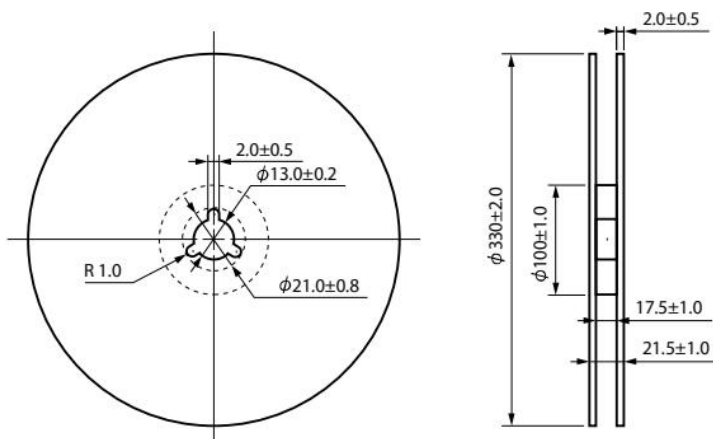
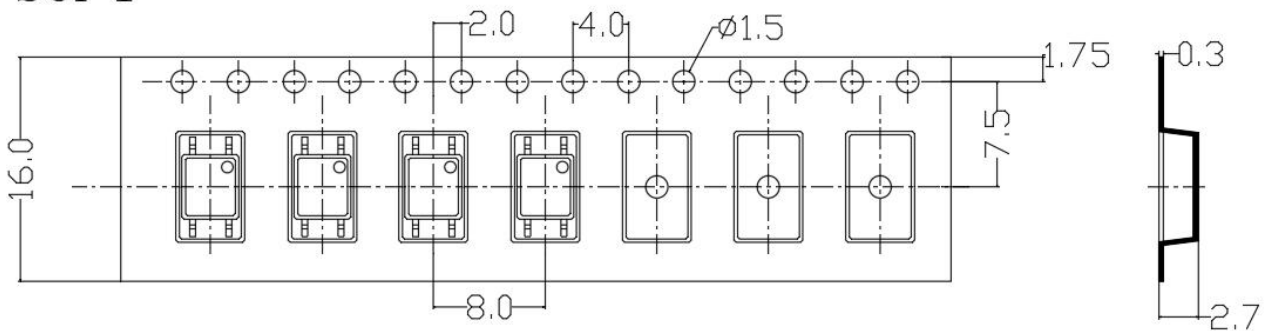

单位: mm

**◆ 可靠性测试 Reliability Test Items And Conditions**

实验项目 Test Items	参考标准 Reference	实验条件 Test Conditions	时间 Time	样品数 Quantity	判据 Criterion
可焊性 Solderability	JESD22-B102	Tsol= (245±5) °C, t=5s;	1 次1 times	22	0/22
耐焊接热 Resistance to Soldering Heat	JESD22-A106	Tsol= (260±5) °C, t=10s	3 次3 times	22	0/22
静电放电 ESD-HBM	JESD22-A114	Ta=25°C, HBM (2000V)	正反各 3 次 P&N 3 times	10	0/10
高温贮存 High emperature Storage	JESD22-A103	Ta=125°C	1000h	22	0/22
低温贮存 Low Temperature Storage	JESD22-A119	Ta= -55°C	1000h	22	0/22
冷热冲击 Thermal Shock	JESD22-A104	-55°C(15min)←→ 125°C(15min)	循环 300 次 300 cycles	22	0/22
常温寿命试验 Lifespan Test	JESD22-A108	Ta=25°C, IF=50mA , Vcc=5V	1000h	22	0/22
高温寿命试验 DC Operating Life	JESD22-A108	Ta=110°C, IF=20mA , Vcc=5V	1000h	76	0/76
高温高湿偏压 High Temperature High Humidity bias Voltage	JESD22-A101	Ta =85°C , RH=85% IF=0mA , VCE=64V	1000h	22	0/22
高温偏压 High Temperature bias Voltage	JESD22-A108	Ta =110°C , IF=0mA , VCE=80V	1000h	22	0/22
高压蒸汽试验 High pressure steam test	JESD22-A102	P=15PSIG , 121°C, 100%RH	96h	22	0/22

## ◆ 回流焊温度曲线图 Solder Reflow Profile

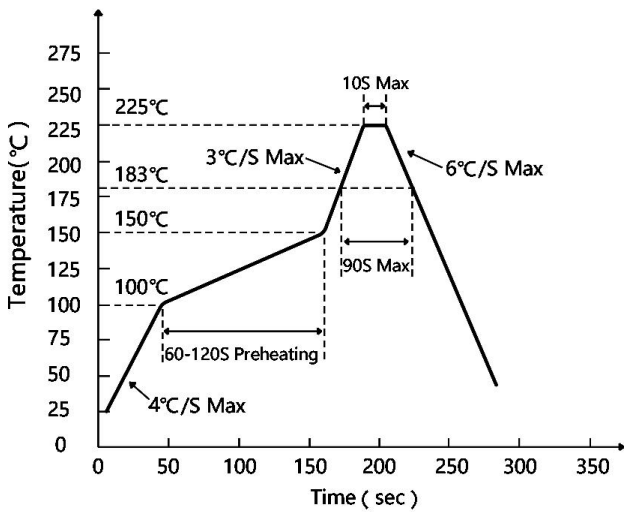

有铅制程 Lead Process

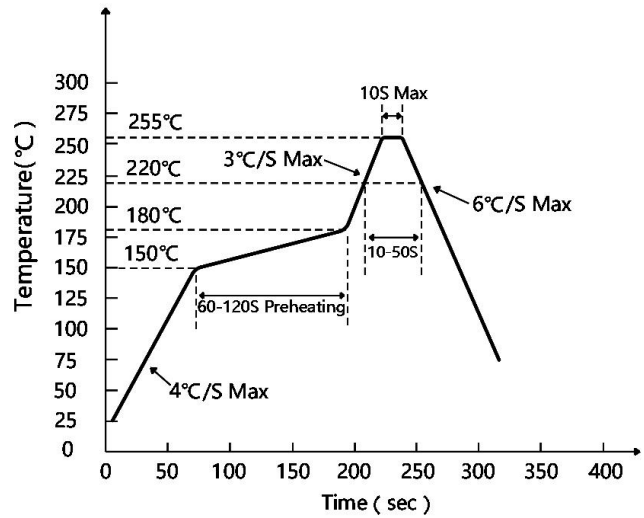

无铅制程 Lead Process

## ◆ 波峰焊温度曲线图 Wave Soldering Profile

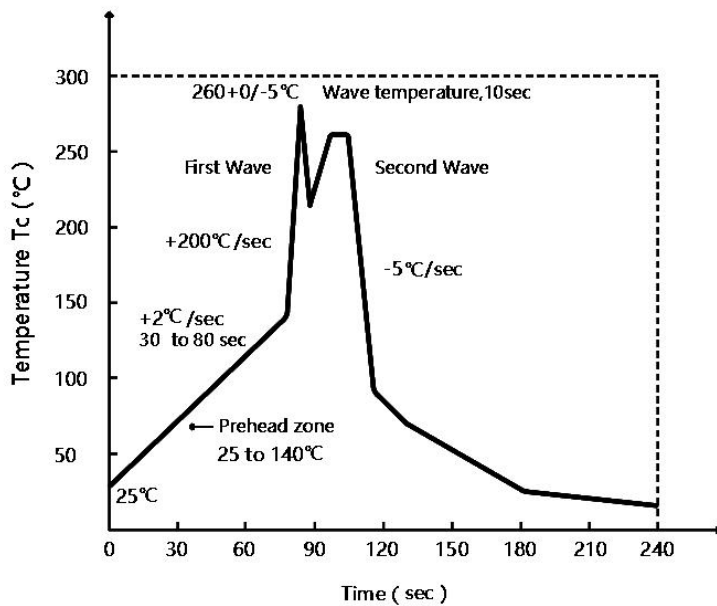

## ◆ 手工烙铁焊接 Soldering with hand soldering iron

A. 手工烙铁焊仅用于产品返修或样品测试;

Hand soldering iron is only used for product rework or sample testing;

B. 手工烙铁焊要求: 温度  $350^{\circ}\text{C} \pm 5^{\circ}\text{C}$ , 时间  $\leq 3\text{s}$ .

Hand soldering iron requirements: Temperature:  $350^{\circ}\text{C} \pm 5^{\circ}\text{C}$ , within 3s.

#### ◆ 注意 Attention

- 奥特半导体实施动态技术迭代机制，产品规格可能随工艺升级调整，最新技术参数以官网发布版本为准。

AOTE implements dynamic technical updates. Specifications are subject to change. Refer to the official website for the latest version.

- 用户需严格遵循本规格书限定的操作条件，因超范围使用（包括但不限于过载、高温、非兼容电路设计）导致的器件失效，不在质量保证范围内。

Users must strictly adhere to specified conditions. Failures caused by misuse (overload, high temperature, incompatible circuits) are excluded from warranty.

- 医疗设备、工业控制等关键场景应用前，需联系技术支持获取定制化验证方案。

Contact technical support for customized validation in critical applications (medical devices, industrial control).

- 本文档有效期至2025年12月31日，后续更新将通过官网公告推送。

This document is valid until Dec 31, 2025. Updates will be notified on the official website.

- 如需对技术参数或应用方案进行进一步确认，欢迎通过以下渠道获取官方支持：

For further clarification on technical specifications or application solutions, please contact us through official channels: