

DS90UB921-Q1 5 - 96 MHz 24-bit Color FPD-Link III Serializer with Bidirectional Control Channel

1 Features

- Qualified for Automotive Applications
- AEC-Q100 Qualified With the Following Results:
 - Device Temperature Grade 2: -40°C to +105°C Ambient Operating Temperature Range
 - Device HBM ESD Classification Level $\pm 8kV$
 - Device CDM ESD Classification Level C6
- Supports Extended High Definition (1920x720p/60Hz) Digital Video Format
- 5 – 96MHz PCLK Supported (STP mode)
- 15 – 96MHz PCLK Supported (Coax mode)
- RGB888 + VS, HS, and DE
- Parallel LVCMOS Video Inputs
- Spread Spectrum Tolerant Input
- 4 Optional Bidirectional GPIO Channels
- Bidirectional Control Interface Channel Interface with I²C Compatible Serial Control Bus
- Optional I²S Support
- AC-Coupled Coax or STP Interconnect Up to 10 meters
- Single 3.3 V Operation with 1.8 V or 3.3 V Compatible LVCMOS I/O Interface
- DC-Balanced and Scrambled Data with Embedded Clock
- Internal Pattern Generation
- Low Power Modes Minimize Power Dissipation
- >8kV ISO 10605 ESD Rating

2 Applications

- Automotive Touch Screen Display
- Automotive Display for Navigation
- Automotive Instrument Cluster

3 Description

The DS90UB921-Q1 serializer, in conjunction with a DS90UB922-Q1, DS90UB926Q-Q1, DS90UB928Q-Q1, DS90UB948-Q1, or DS90UB940-Q1 deserializer, provides a complete digital interface for concurrent transmission of high-speed video, audio, and control data for automotive display and image sensing applications.

The chipset is ideally suited for automotive video-display systems with WVGA and HD formats. The DS90UB921-Q1 incorporates an embedded bidirectional control channel and low latency GPIO controls. This chipset translates a parallel interface into a single pair high-speed serialized interface. The serial bus scheme, FPD-Link III, supports full duplex of high-speed video data transmission and bidirectional control communication over a single link. Consolidation of video data and control over a single differential pair (or single wire) reduces the interconnect size and weight, while also eliminating skew issues and simplifying system design.

The DS90UB921-Q1 serializer embeds the clock, DC scrambles & balances the data payload, and level shifts the signals to high-speed low voltage differential (or single-ended) signaling. Up to 24 data bits are serialized along the video control signals.

EMI is minimized by the use of low voltage swing signaling, data scrambling and randomization and spread spectrum clocking compatibility.

Remote interrupts from the downstream deserializer are mirrored to a local output pin.

Device Information (1)

PART NUMBER	PACKAGE	BODY SIZE (NOM)
DS90UB921-Q1	WQFN (48)	7.00 mm x 7.00 mm

(1) For all available packages, see the orderable addendum at the end of the data sheet.

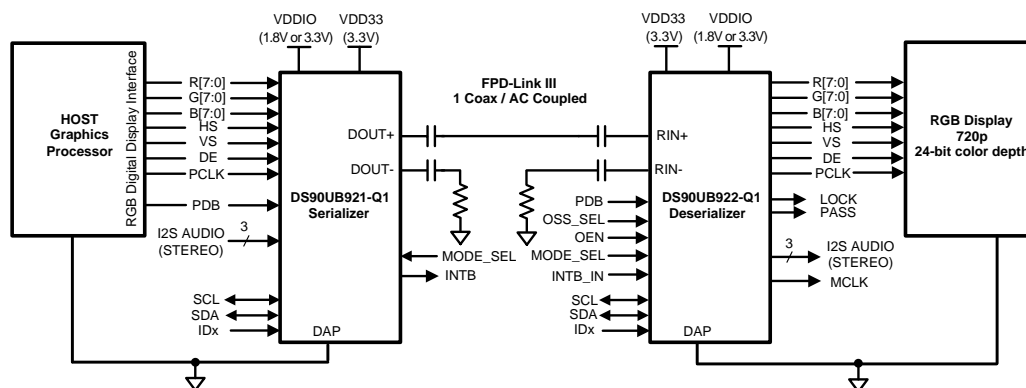

Table of Contents

1 Features	1	7.4 Device Functional Modes.....	24
2 Applications	1	7.5 Programming	27
3 Description	1	7.6 Register Maps	28
4 Revision History	2	8 Application and Implementation	40
5 Pin Configuration and Functions	3	8.1 Application Information.....	40
6 Specifications	6	8.2 AVMUTE Operation	40
6.1 Absolute Maximum Ratings	6	8.3 Typical Application	41
6.2 ESD Ratings - JEDEC	6	9 Power Supply Recommendations	45
6.3 ESD Ratings—IEC and ISO.....	6	9.1 Power Up Requirements and PDB Pin.....	45
6.4 Recommended Operating Conditions.....	6	9.2 CML Interconnect Guidelines.....	46
6.5 Thermal Information	7	10 Layout	47
6.6 DC Electrical Characteristics	7	10.1 Layout Guidelines	47
6.7 AC Electrical Characteristics.....	9	10.2 Layout Example	48
6.8 PCLK Timing Requirements	9	11 Device and Documentation Support	51
6.9 Recommended Timing for the Serial Control Bus ..	10	11.1 Documentation Support	51
6.10 Switching Characteristics	13	11.2 Community Resources.....	51
6.11 Typical Characteristics	14	11.3 Trademarks	51
7 Detailed Description	15	11.4 Electrostatic Discharge Caution.....	51
7.1 Overview	15	11.5 Glossary	51
7.2 Functional Block Diagram	15	12 Mechanical, Packaging, and Orderable Information	51
7.3 Feature Description.....	15		

4 Revision History

DATE	REVISION	NOTES
March 2016	*	Initial release.

5 Pin Configuration and Functions

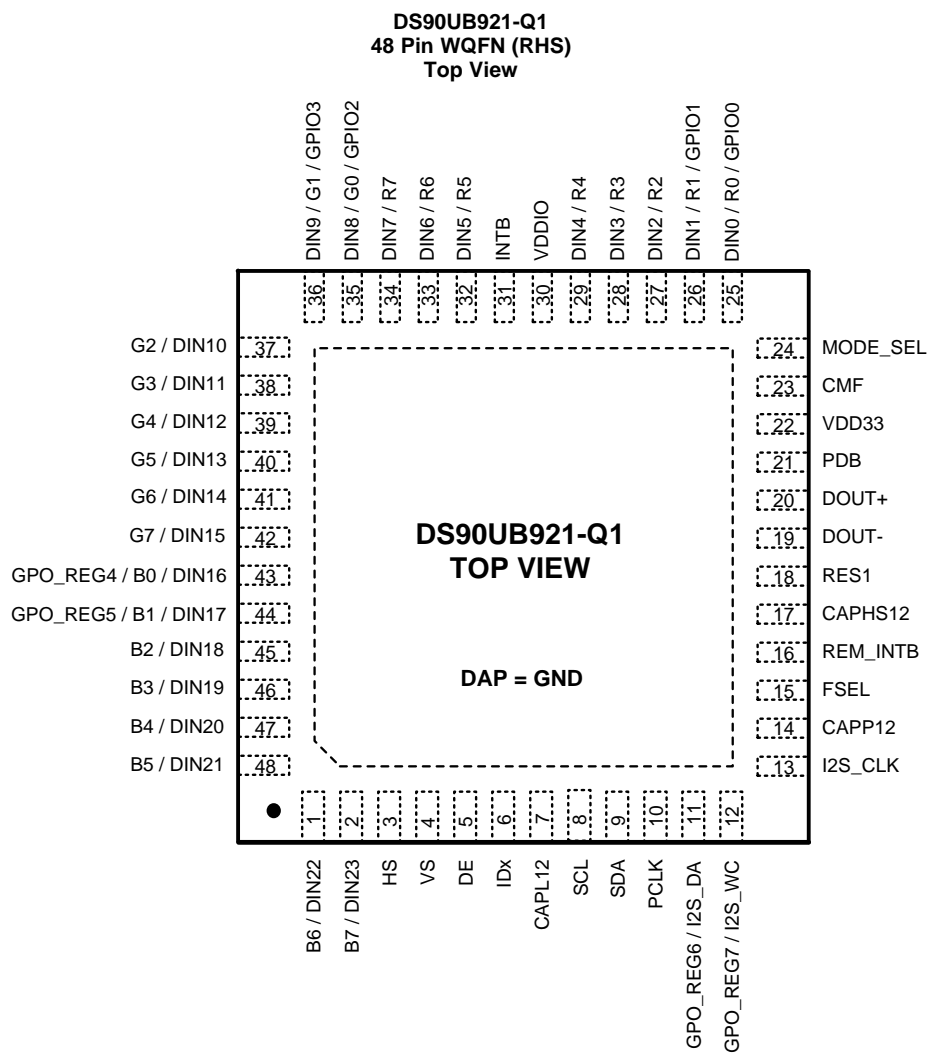

Pin Functions

PIN		I/O, TYPE	DESCRIPTION
NAME	NUMBER		
LVC MOS PARALLEL INTERFACE - Layout note: for unused LVC MOS input pins, tie to an external pulldown			
DIN[23:18], DIN[15:10], DIN[7:2] / R[7:2], G[7:2], B[7:2]	27, 28, 29, 32, 33, 34, 37, 38, 39, 40, 41, 42, 45, 46, 47, 48, 1, 2	I, LVC MOS, PD	Parallel Interface Data Input Pins
DIN[1:0], DIN[9:8], DIN[17:16] / R[1:0], G[1:0], B[1:0]	25, 26, 35, 36, 43, 44	Multi-function pin I/O, LVC MOS, PD	Parallel Interface Data Input Pins DIN0 / R0 can optionally be used as GPIO0 and DIN1 / R1 can optionally be used as GPIO1 DIN8 / G0 can optionally be used as GPIO2 and DIN9 / G1 can optionally be used as GPIO3 DIN16 / B0 can optionally be used as GPO_REG4 and DIN17 / B1 can optionally be used as GPO_REG5

Pin Functions (continued)

PIN		I/O, TYPE	DESCRIPTION
NAME	NUMBER		
HS	3	I, LVCMOS, PD	Horizontal Sync Input Pin Video control signal pulse width must be 3 PCLKs or longer to be transmitted when the Control Signal Filter is enabled. There is no restriction on the minimum transition pulse when the Control Signal Filter is disabled. The signal is limited to 2 transitions per 130 PCLKs. See Video Control Signal Filter .
VS	4	I, LVCMOS, PD	Vertical Sync Input Pin Video control signal is limited to 1 transition per 130 PCLKs. Thus, the minimum pulse width is 130 PCLKs. See Video Control Signal Filter .
DE	5	I, LVCMOS, PD	Data Enable Input Pin Video control signal pulse width must be 3 PCLKs or longer to be transmitted when the Control Signal Filter is enabled. There is no restriction on the minimum transition pulse when the Control Signal Filter is disabled. The signal is limited to 2 transitions per 130 PCLKs. See Video Control Signal Filter .
PCLK	10	I, LVCMOS, PD	Pixel Clock Input Pin. Strobe edge set by TRFB configuration register. See Table 7 0x03[0].
I2S_CLK, I2S_WC, I2S_DA	13, 12, 11	Multi-function pin I, LVCMOS, PD	Digital Audio Interface Data Input Pins Leave open if unused I2S_CLK can optionally be used as GPO_REG8, I2S_WC can optionally be used as GPO_REG7, and I2S_DA can optionally be used as GPO_REG6.
OPTIONAL PARALLEL INTERFACE - <i>Layout note: for unused interface pins, tie to an external pulldown</i>			
GPIO[3:0]	36, 35, 26, 25	Multi-function pin I/O, LVCMOS, PD	General Purpose IOs. Available only in 18-bit color mode, and set by MODE_SEL pin or configuration register. See Table 7 0x0D - 0x0F. Leave open if unused. Shared with DIN9, DIN8, DIN1 and DIN0
GPO_REG[7:4]	12, 11, 44, 43	Multi-function pin O, LVCMOS, PD	General Purpose Outputs and set by configuration register. See Table 7 0x0F - 0x11. Share with I2S_WC, I2S_DA, or DIN17, DIN16.
CONTROL			
PDB	21	I, LVCMOS, PD	Power-down Mode Input Pin PDB = H, device is enabled (normal operation) Refer to Power Up Requirements and PDB Pin section. PDB = L, device is powered down. When the device is in the powered down state, the Driver Outputs are both HIGH, the PLL is shutdown, and IDD is minimized. Control Registers are RESET .
MODE_SEL	24	S	Device Configuration Select. See Table 5 .
FSEL	15	I, LVCMOS, PU	Frequency Mode Select. Enables Intermediate Frequency mode for coaxial operation. See Frequency Mode Optimizations .
I²C			
IDx	6	S	I ² C Serial Control Bus Device ID Address Select External pull-up to VDD33 is required under all conditions, DO NOT FLOAT. Connect to external pull-up and pull-down resistor to create a voltage divider. See Table 6 .
SCL	8	I/O, Open Drain	I ² C Clock Input / Output Interface Must have an external pull-up to VDD33, DO NOT FLOAT. Recommended pull-up: 4.7kΩ.
SDA	9	I/O, Open Drain	I ² C Data Input / Output Interface Must have an external pull-up to VDD33, DO NOT FLOAT. Recommended pull-up: 4.7kΩ.

Pin Functions (continued)

PIN		I/O, TYPE	DESCRIPTION
NAME	NUMBER		
STATUS - Layout note: for unused interface pins, leave as No Connect			
INTB	31	O, Open Drain	Interrupt INTB = H, normal INTB = L, Interrupt request Typically connected with 4.7kΩ to VDDIO.
REM_INTB	16	O, LVCMOS, PD	Interrupt. Mirrors status of INTB_IN from the remote deserializer. Note: REM_INTB will be driven LOW until lock is achieved with the downstream deserializer. REM_INTB = H, normal REM_INTB = L, interrupt request
FPD-LINK III SERIAL INTERFACE			
DOUT+	20	O, LVDS	True Output The output must be AC-coupled per the typical connection diagram.
DOUT-	19	O, LVDS	Inverting Output The output must be AC-coupled per the typical connection diagram.
CMF	23	CAP	Common Mode Filter. Typically connected with 0.1μF to GND
POWER AND GROUND ⁽¹⁾			
VDD33	22	Power	Power to on-chip regulator 3.0 V - 3.6 V . Typically connected with 4.7 uF to GND
VDDIO	30	Power	LVCMOS I/O Power 1.71 V - 1.89 V OR 3.0 V - 3.6 V . Typically connected with 4.7 uF to GND
GND	DAP	Ground	DAP is the large metal contact at the bottom side, located at the center of the WQFN package. Connect to the ground plane (GND) with at least 9 vias.
REGULATOR CAPACITOR			
CAPHS12, CAPP12	17, 14	CAP	Decoupling capacitor connection for on-chip regulator. Typically connected with 4.7uF to GND at each CAP pin.
CAPL12	7	CAP	Decoupling capacitor connection for on-chip regulator. Typically connected with two 4.7uF to GND at this CAP pin.
OTHERS			
RES1	18	GND	Reserved. Tie to Ground.

(1) The VDD (VDD33 and VDDIO) supply ramp should be faster than 1.5 ms with a monotonic rise.

The definitions below define the functionality of the I/O cells for each pin. I/O TYPE:

- CAP = Capacitor connection
- LVCMOS = LVCMOS pin; Referenced to VDDIO IO supply
- I = Input
- O = Output
- I/O = Input/Output
- S = Strap pin. All strap pins have weak internal pull-ups or pull-downs. If the default strap value is needed to be changed then an external resistor should be used.
- PD, PU = Weak Internal Pull-Down/Pull-Up
- Multi-function pin

6 Specifications

6.1 Absolute Maximum Ratings

over operating free-air temperature range (unless otherwise noted)⁽¹⁾⁽²⁾

	MIN	MAX	UNIT
Supply voltage – VDD33	-0.3	4	V
Supply voltage – VDDIO	-0.3	4	V
LVC MOS I/O voltage	-0.3	VDDIO + 0.3	V
Serializer output voltage - DOOUT±	-0.3	2.75	V
Junction temperature		150	°C
Storage temperature, T _{stg}	-65	150	°C

- (1) Stresses beyond those listed under *Absolute Maximum Ratings* may cause permanent damage to the device. These are stress ratings only, which do not imply functional operation of the device at these or any other conditions beyond those indicated under *Recommended Operating Conditions*. Exposure to absolute-maximum-rated conditions for extended periods may affect device reliability.
- (2) If Military/Aerospace specified devices are required, please contact the Texas Instruments Sales Office/ Distributors for availability and specifications.

6.2 ESD Ratings - JEDEC

		VALUE	UNIT
V _(ESD)	Electrostatic discharge	Human-body model (HBM), per AEC Q100-002 ⁽¹⁾	±8000
		Charged-device model (CDM), per AEC Q100-011	±1500

- (1) AEC Q100-002 indicates that HBM stressing shall be in accordance with the ANSI/ESDA/JEDEC JS-001 specification.

6.3 ESD Ratings—IEC and ISO

			VALUE	UNIT	
V _(ESD)	Electrostatic discharge	R _D = 330 Ω, C _S = 150 pF	IEC, powered-up only contact discharge (DOOUT+, DOOUT-)	±8000	V
			IEC, powered-up only air-gap discharge (DOOUT+, DOOUT-)	±18000	
		R _D = 330 Ω, C _S = 150 and 330 pF	ISO10605 contact discharge (DOOUT+, DOOUT-)	±8000	V
			ISO10605 air-gap discharge (DOOUT+, DOOUT-)	±18000	
		R _D = 2 kΩ, C _S = 150 and 330 pF	ISO10605 contact discharge (DOOUT+, DOOUT-)	±8000	V
			ISO10605 air-gap discharge (DOOUT+, DOOUT-)	±18000	

6.4 Recommended Operating Conditions

	MIN	NOM	MAX	UNIT
Supply voltage (VDD33)	3	3.3	3.6	V
LVC MOS supply voltage (VDDIO)	3	3.3	3.6	V
	1.71	1.8	1.89	V
Operating free-air temperature (T _A)	-40	25	105	°C
PCLK frequency, Coax operation, high frequency mode ⁽¹⁾	48		96	MHz
PCLK frequency, Coax operation, intermediate frequency mode ⁽¹⁾	24		48	MHz
PCLK frequency, Coax operation, low frequency mode ⁽¹⁾	15		24	MHz
PCLK frequency, STP operation, high frequency mode ⁽¹⁾	15		96	MHz
PCLK frequency, STP operation, low frequency mode ⁽¹⁾	5		15	MHz
Supply noise -- (DC-50MHz)			100	mV _{P-P}

- (1) For configuration of cable type and frequency mode, refer to [Frequency Mode Optimizations](#).

6.5 Thermal Information

THERMAL METRIC ⁽¹⁾		DS90UB921-Q1	UNIT
		RHS (WQFN)	
		48 PINS	
R _{θJA}	Junction-to-ambient thermal resistance	29	°C/W
R _{θJC(top)}	Junction-to-case (top) thermal resistance	11.7	
R _{θJB}	Junction-to-board thermal resistance	5.0	
ψ _{JT}	Junction-to-top characterization parameter	0.1	
ψ _{JB}	Junction-to-board characterization parameter	6.0	
R _{θJC(bot)}	Junction-to-case (bottom) thermal resistance	1.7	

(1) For more information about traditional and new thermal metrics, see the *IC Package Thermal Metrics* application report, [SPRA953](#).

6.6 DC Electrical Characteristics

over operating free-air temperature range (unless otherwise noted)⁽¹⁾⁽²⁾⁽³⁾

PARAMETER	TEST CONDITIONS		PIN/FREQ.	MIN	TYP	MAX	UNIT
LVCMOS I/O DC SPECIFICATIONS							
V _{IH}	High-level input voltage	VDDIO = 3 V to 3.6 V	PDB	2		VDDIO	V
V _{IL}	Low-level input voltage	VDDIO = 3 V to 3.6 V		GND		0.8	V
I _{IN}	Input current	V _{IN} = 0 V or V _{IN} = VDDIO (3 V to 3.6 V)		-10	±1	10	µA
V _{IH}	High-level input voltage	VDDIO = 3 V to 3.6 V	DIN[23:0], HS, VS, DE, PCLK, I2S_CLK, I2S_WC, I2S_DA	2		VDDIO	V
		VDDIO = 1.71 V to 1.89 V		0.65 × VDDIO		VDDIO	V
V _{IL}	Low-level input voltage	VDDIO = 3 V to 3.6 V		GND		0.8	V
		VDDIO = 1.71 V to 1.89 V		GND		0.35 × VDDIO	V
I _{IN}	Input current	V _{IN} = 0 V or V _{IN} = VDDIO		-10	±1	10	µA
		VDDIO = 3 V to 3.6 V		-10	±1	10	µA
		VDDIO = 1.71 V to 1.89 V					
V _{OH}	High-level output voltage	I _{OH} = -4 mA	GPIO[3:0], GPO_REG[7:4], REM_INTB	2.4		VDDIO	V
		VDDIO = 3 V to 3.6 V		VDDIO - 0.45		VDDIO	V
		VDDIO = 1.71 V to 1.89 V		GND		0.4	V
V _{OL}	Low-level output voltage	I _{OH} = 4 mA		GND		0.35	V
		VDDIO = 3 V to 3.6 V					
		VDDIO = 1.71 V to 1.89 V					
I _{OS}	Output short-circuit current	V _{OUT} = 0 V			-50		mA
I _{OZ}	TRI-STATE output current	V _{OUT} = 0 V or V _{OUT} = VDDIO PDB = L			-10		10 µA

- (1) The *Electrical Characteristics* tables list ensured specifications under the listed *Recommended Operating Conditions* except as otherwise modified or specified by the Electrical Characteristics conditions and/or Notes. Typical specifications are estimations only and are not ensured.
- (2) Typical values represent most likely parametric norms at nominal conditions at the time of product characterization and are not ensured.
- (3) Current into device pins is defined as positive. Current out of a device pin is defined as negative. Voltages are referenced to ground except V_{OD} and ΔV_{OD}, which are differential voltages.

DC Electrical Characteristics (continued)

 over operating free-air temperature range (unless otherwise noted)⁽¹⁾⁽²⁾⁽³⁾

PARAMETER	TEST CONDITIONS	PIN/FREQ.	MIN	TYP	MAX	UNIT
FPD-LINK III CML DRIVER DC SPECIFICATIONS						
V _{OD}	Differential output voltage (DOUT+) – (DOUT–)	R _L = 100 Ω, see Figure 1	700	800	1000	mVp-p
V _{OUT}	Single-ended output voltage (DOUT+ or DOUT–)	R _L = 50 Ω See Figure 2	350	400	500	mV
ΔV _{OD}	Output voltage unbalance			1	50	mV
V _{OS}	Offset voltage — single-ended	R _L = 100 Ω See Figure 1		2.5 – 0.5 × V _{OD}		V
ΔV _{OS}	Offset voltage unbalanced single-ended			1	50	mV
I _{OS}	Output short-circuit current	DOUT± = 0 V, PDB = L or H		–38		mA
R _T	Internal termination resistor — single-ended		40	50	62	Ω
SERIAL CONTROL BUS						
V _{IH}	Input high level, I2C		0.7 × VDD33		VDD33	V
V _{IL}	Input low-level voltage, I2C				0.3 × VDD33	V
V _{HY}	Input hysteresis, I2C		> 50			mV
V _{OL}	Output Low Level, I2C	I _{OL} = +1.25mA	0		0.36	V
I _{IN}	Input Current, I2C	V _{IN} = 0V or V _{IN} = VDD33	–10		10	μA
C _{IN}	Input capacitance, I2C		< 5			pF
SUPPLY CURRENT						
I _{DD1}	Supply Current (includes load current) R _L = 100Ω, f = 96MHz	Checker Board Pattern, See Figure 3	VDD33 = 3.6V	148	180	mA
I _{DDIO1}			VDDIO = 3.6V	90	180	μA
			VDDIO = 1.89V	1	3	mA
I _{DDS1}	Supply Current Remote Auto Power Down Mode	0x01[7] = 1, deserializer is powered down	VDD33 = 3.6V	1.2	3	mA
I _{DDIOS1}			VDDIO = 3.6V	65	200	μA
			VDDIO = 1.89V	55	200	μA
I _{DDS2}	Supply Current Power Down	PDB = L, All LVCMOS inputs are not connected (NC) or tied to GND	VDD33 = 3.6V	1	3	mA
I _{DDIOS2}			VDDIO = 3.6V	65	200	μA
			VDDIO = 1.89V	55	200	μA
I _{DDS3}	Supply Current Sleep State	0x01[7] = 1, PCLK is removed.	VDD33 = 3.6V	55		mA
I _{DDIOS3}			VDDIO = 3.6V	80		μA
			VDDIO = 1.89V	1		mA

6.7 AC Electrical Characteristics

 over operating free-air temperature range (unless otherwise noted)⁽¹⁾⁽²⁾⁽³⁾

PARAMETER		TEST CONDITIONS	PIN/FREQUENCY	MIN	TYP	MAX	UNIT
GPIO BIT RATE							
B _{RF}	Forward channel bit rate	See ⁽⁴⁾	$f = 5 - 96 \text{ MHz}$ GPIO[3:0]		$0.25 \times f$		Mbps
B _{RB}	Back channel bit rate	STP cable - HFMODE	GPIO[3:0]		60		kbps
		STP cable - LFMODE Coax cable - HFMODE, IFMODE, or LFMODE			40		kbps

- (1) The *Electrical Characteristics* tables list ensured specifications under the listed *Recommended Operating Conditions* except as otherwise modified or specified by the Electrical Characteristics conditions and/or Notes. Typical specifications are estimations only and are not ensured.
- (2) Typical values represent most likely parametric norms at nominal conditions at the time of product characterization and are not ensured.
- (3) Current into device pins is defined as positive. Current out of a device pin is defined as negative. Voltages are referenced to ground except V_{OD} and ΔV_{OD} , which are differential voltages.
- (4) Specification is ensured by design and is not tested in production.

6.8 PCLK Timing Requirements

 over operating free-air temperature range (unless otherwise noted)⁽¹⁾⁽²⁾⁽³⁾

		MIN	NOM	MAX	UNIT
t _{TCP}	PCLK period with STP cable, see ⁽⁴⁾ $f = 5 \text{ to } 96 \text{ MHz}$	10.41	T	200	ns
	PCLK period with Coax cable, see ⁽⁴⁾ $f = 15 \text{ to } 96 \text{ MHz}$	10.41	T	66.7	ns
t _{CIH}	PCLK input high time; pin/frequency: PCLK	0.4*T	0.5*T	0.6*T	ns
t _{CIL}	PCLK input low time; pin/frequency: PCLK	0.4*T	0.5*T	0.6*T	ns
t _{CLKT}	PCLK input transition time ⁽⁴⁾ , see Figure 4 ; $f = 5 \text{ MHz}$	4			ns
	PCLK input transition time ⁽⁴⁾ , see Figure 4 ; $f = 96 \text{ MHz}$	0.5			ns
t _{JIT}	PCLK input jitter, bit error rate $\leq 10^{-10}$ $f / 40 < \text{jitter freq} < f / 20$ $f = 5 \text{ to } 78 \text{ MHz}$ ⁽⁴⁾⁽⁵⁾ Paired with DS90UB926Q-Q1			0.35	UI
	PCLK input jitter, bit error rate $\leq 10^{-10}$ $f / 40 < \text{jitter freq} < f / 20$ $f = 5 - 85 \text{ MHz}$ ⁽⁴⁾⁽⁵⁾ Paired with DS90UB928Q-Q1			0.35	UI
	PCLK input jitter, bit error rate $\leq 10^{-10}$ $f / 40 < \text{jitter freq} < f / 20$ $f = 25 - 96 \text{ MHz}$ ⁽⁴⁾⁽⁵⁾ Paired with DS90UB940-Q1, or DS90UB948-Q1			0.35	UI

- (1) The *Electrical Characteristics* tables list ensured specifications under the listed *Recommended Operating Conditions* except as otherwise modified or specified by the Electrical Characteristics conditions and/or Notes. Typical specifications are estimations only and are not ensured.
- (2) Typical values represent most likely parametric norms at nominal conditions at the time of product characterization and are not ensured.
- (3) Current into device pins is defined as positive. Current out of a device pin is defined as negative. Voltages are referenced to ground except V_{OD} and ΔV_{OD} , which are differential voltages.
- (4) Specification is ensured by characterization and is not tested in production.
- (5) UI – Unit Interval is equivalent to one serialized data bit width (1UI = 1 / 35 × PCLK). The UI scales with PCLK frequency.

6.9 Recommended Timing for the Serial Control Bus

Over 3.3-V supply and temperature ranges unless otherwise specified.

			MIN	TYP	MAX	UNIT
f_{SCL}	SCL clock frequency	Standard mode	0		100	kHz
		Fast mode	0		400	kHz
t_{LOW}	SCL low period	Standard mode	4.7			μ s
		Fast mode	1.3			μ s
t_{HIGH}	SCL high period	Standard mode	4			μ s
		Fast mode	0.6			μ s
$t_{HD;STA}$	Hold time for a start or a repeated start condition, see Figure 10	Standard mode	4			μ s
		Fast mode	0.6			μ s
$t_{SU;STA}$	Set-up time for a start or a repeated start condition, see Figure 10	Standard mode	4.7			μ s
		Fast mode	0.6			μ s
$t_{HD;DAT}$	Data hold time, see Figure 10	Standard mode	0	0.615	3.45	μ s
		Fast mode	0	0.615	0.9	μ s
$t_{SU;DAT}$	Data set-up time, see Figure 10	Standard mode	250	0.56		ns
		Fast mode	100	0.56		ns
$t_{SU;STO}$	Set-up time for STOP condition, See Figure 10	Standard mode	4			μ s
		Fast mode	0.6			μ s
t_{BUF}	Bus free time between STOP and START, See Figure 10	Standard mode	4.7			μ s
		Fast mode	1.3			μ s
t_r	SCL and SDA rise time, See Figure 10	Standard mode		430	1000	ns
		Fast mode		200	300	ns
t_f	SCL and SDA fall time, See Figure 10	Standard mode		20	300	ns
		Fast mode		20	300	ns
t_{sp}	Input filter			50	ns	

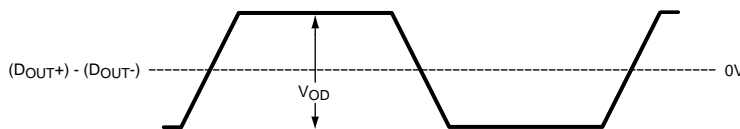
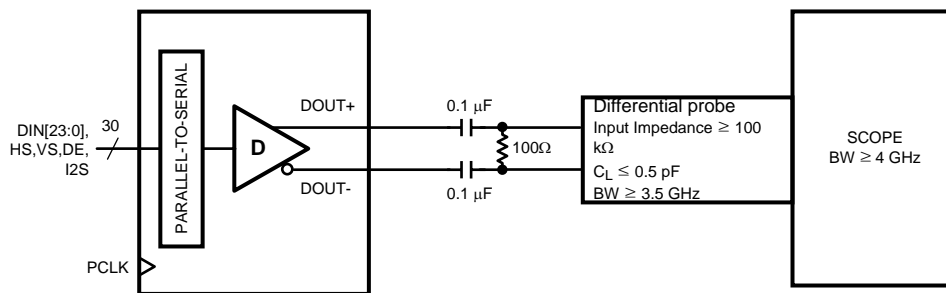

Figure 1. Serializer Differential V_{OD} DC Output

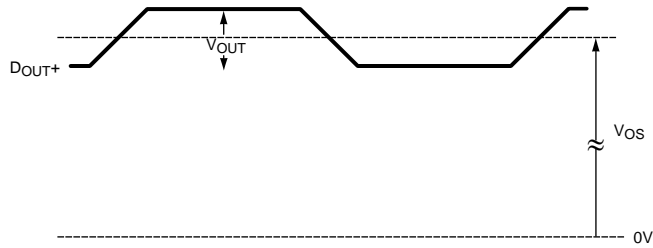
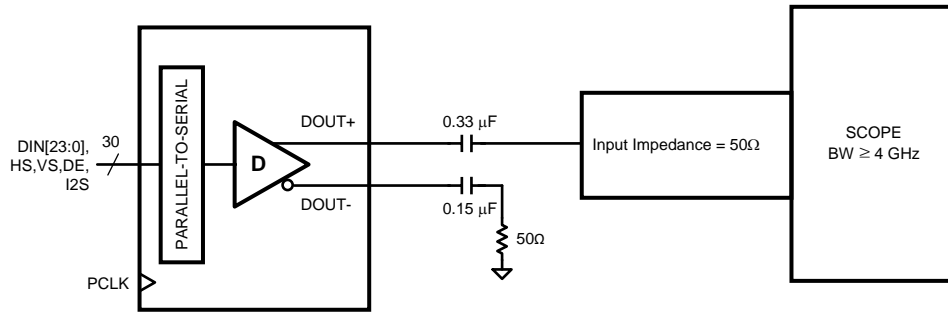

Figure 2. Serializer Single-ended V_{OUT} DC Output

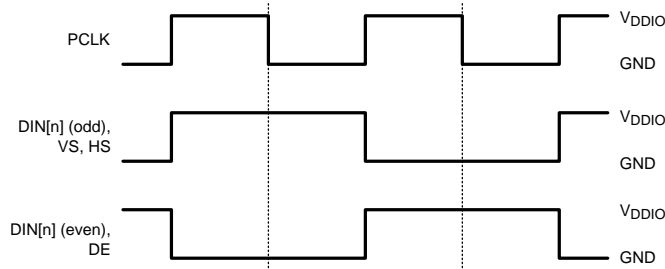

Figure 3. Checker Board Data Pattern

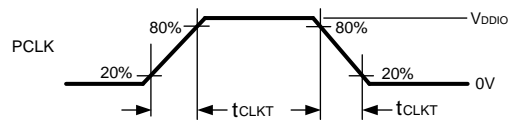

Figure 4. Serializer Input Clock Transition Time

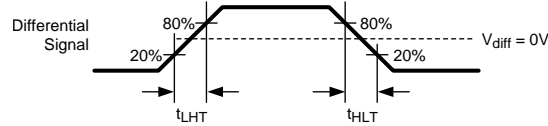

Figure 5. Serializer CML Output Load and Transition Time

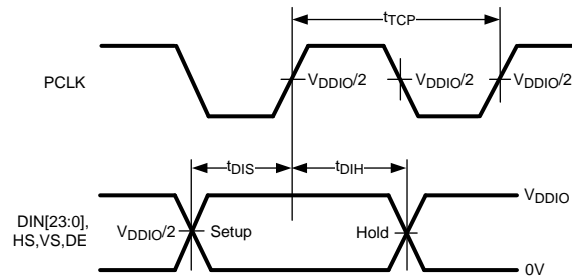

Figure 6. Serializer Setup and Hold Times

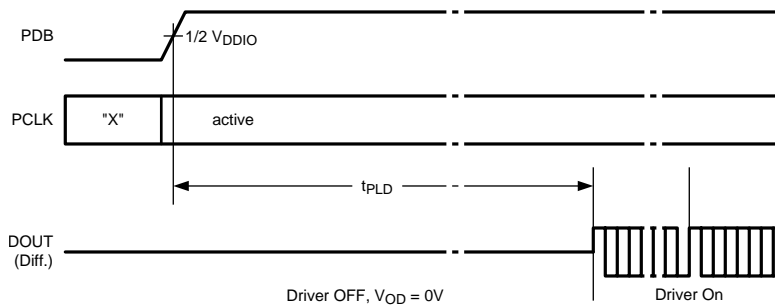

Figure 7. Serializer Lock Time

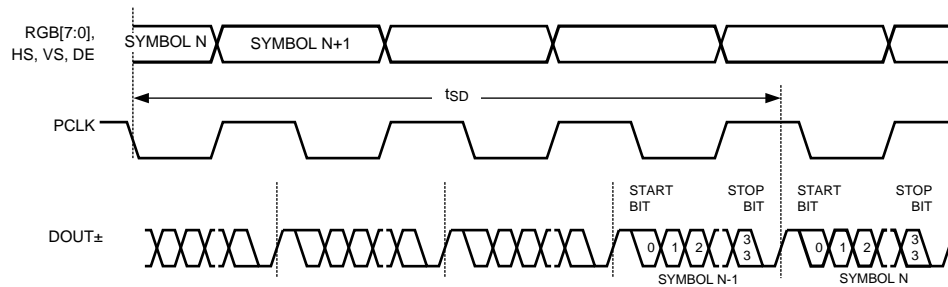

Figure 8. Serializer Delay Time

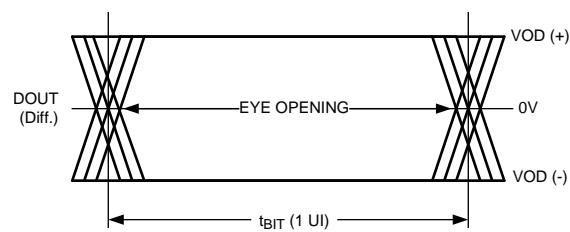

Figure 9. Serializer CML Output Jitter

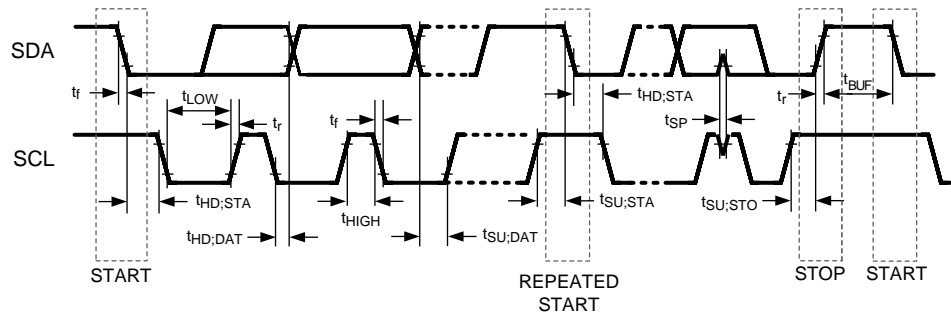

Figure 10. Serial Control Bus Timing Diagram

6.10 Switching Characteristics

over operating free-air temperature range (unless otherwise noted)

PARAMETER	TEST CONDITIONS	PIN/FREQ.	MIN	TYP	MAX	UNIT
t_{LHT}	CML Output Low-to-High Transition Time	See Figure 5		80		ps
t_{HLT}	CML Output High-to-Low Transition Time					
t_{DIS}	Data Input Setup to PCLK	See Figure 6	2.0			ns
t_{DIH}	Data Input Hold from PCLK					
t_{PLD}	Serializer PLL Lock Time	See Figure 7 ⁽¹⁾		131*T		ns
t_{SD}	Delay — Latency	See Figure 8		145*T		ns
t_{TJIT}	Output Total Intrinsic Jitter, Jitter frequency > f/10 Bit Error Rate $\geq 10^{-10}$ (2) (3)	$R_L = 100\Omega$ $f = 96\text{MHz}$ See Figure 9		0.25	0.30	UI

(1) t_{PLD} is the time required by the device to obtain lock when exiting power-down state with an active PCLK

(2) Specification is ensured by characterization and is not tested in production.

(3) UI – Unit Interval is equivalent to one serialized data bit width $1\text{UI} = 1 / (35 * \text{PCLK})$. The UI scales with PCLK frequency.

6.11 Typical Characteristics

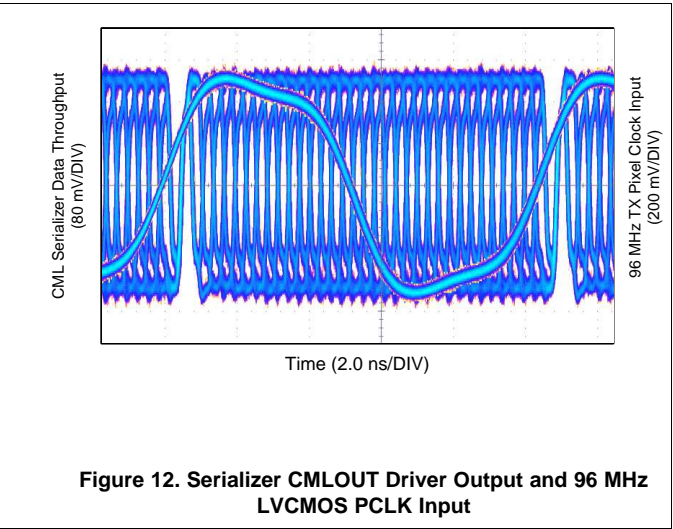
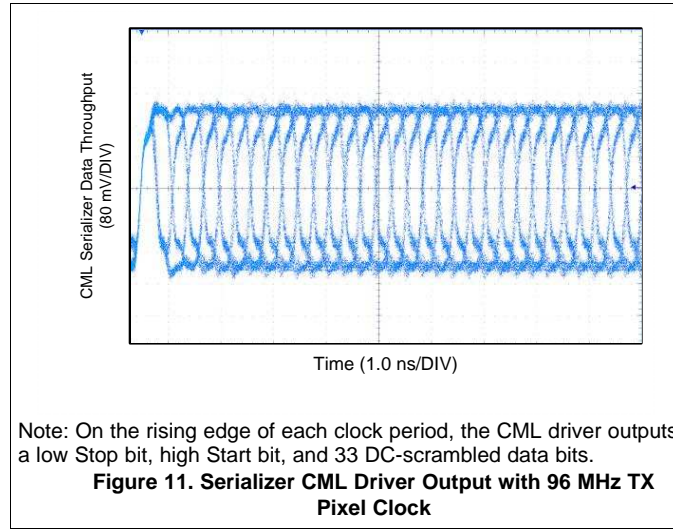

7 Detailed Description

7.1 Overview

The DS90UB921-Q1 serializer transmits a 35-bit symbol over a single serial FPD-Link III channel operating up to 3.36 Gbps line rate. The serial stream contains an embedded clock, video control signals and DC-balanced video data and audio data which enhance signal quality to support AC coupling. The serializer is intended for use with the DS90UB926Q-Q1, DS90UB928Q-Q1, DS90UB948-Q1, or DS90UB940-Q1 deserializers.

The DS90UB921-Q1 serializer and compatible deserializer incorporate an I²C compatible interface. The I²C compatible interface allows programming of serializer or deserializer devices from a local host controller. In addition, the devices incorporate a bidirectional control channel (BCC) that allows communication between serializer/deserializer as well as remote I²C slave devices.

The bidirectional control channel is implemented via embedded signaling in the high-speed forward channel (serializer to deserializer) as well as lower speed signaling in the reverse channel (deserializer to serializer). Through this interface, the BCC provides a mechanism to bridge I²C transactions across the serial link from one I²C bus to another. The implementation allows for arbitration with other I²C compatible masters at either side of the serial link.

There are two operating modes available on DS90UB921-Q1, display mode and camera mode. In display mode, I²C transactions originate from the host controller attached to the serializer and target either the deserializer or an I²C slave attached to the deserializer. Transactions are detected by the I²C slave in the serializer and forwarded to the I²C master in the deserializer. Similarly, in camera mode, I²C transactions originate from a controller attached to the deserializer and target either the serializer or an I²C slave attached to the serializer. Transactions are detected by the I²C slave in the deserializer and forwarded to the I²C master in the serializer.

7.2 Functional Block Diagram

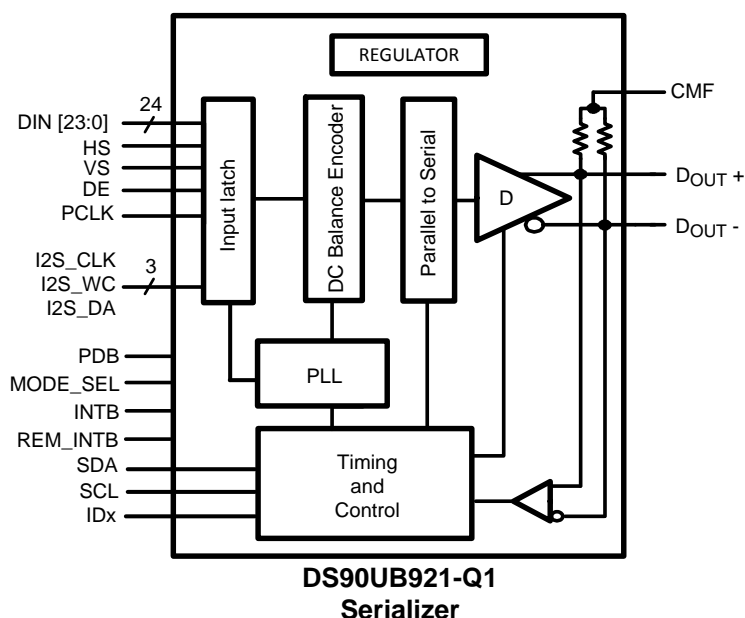

7.3 Feature Description

7.3.1 High Speed Forward Channel Data Transfer

The High Speed Forward Channel (HS_FC) is composed of 35 bits of data containing DIN[23:0] or RGB[7:0] or YUV data, sync signals, I²C, and I2S audio transmitted from Serializer to Deserializer. Figure 13 illustrates the serial stream per PCLK cycle. This data payload is optimized for signal transmission over an AC coupled link. Data is randomized, balanced and scrambled.

Feature Description (continued)

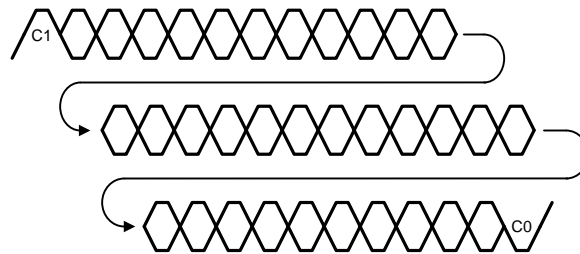

Figure 13. FPD-Link III Serial Stream

The device supports clocks in the range of 5 MHz to 96 MHz. The actual line rate is 3.36 Gbps maximum and 525 Mbps Minimum.

7.3.2 Low Speed Back Channel Data Transfer

The Low-Speed Backward Channel (LS_BC) of the DS90UB921-Q1 provides bidirectional communication between the display and host processor. The information is carried back from the Deserializer to the Serializer per serial symbol. The back channel control data is transferred over the single serial link along with the high-speed forward data, DC balance coding and embedded clock information. This architecture provides a backward path across the serial link together with a high speed forward channel. The back channel contains the I²C, CRC and 4 bits of standard GPIO information with 3.1 Mbps line rate in Coax mode and low frequency STP mode, and 4.4Mbps line rate in high frequency STP mode. The back channel data rate is configured automatically when STP or Coax is selected (see [Frequency Mode Optimizations](#)).

7.3.3 Common Mode Filter Pin (CMF)

The serializer provides access to the center tap of the internal termination. A capacitor must be placed on this pin for additional common-mode filtering of the differential pair. This can be useful in high noise environments for additional noise rejection capability. A 0.1 μ F capacitor must be connected to this pin to Ground.

7.3.4 Video Control Signal Filter

When operating the devices in Normal Mode, the Video Control Signals (DE, HS, VS) have the following restrictions:

- Normal Mode with Control Signal Filter Enabled: DE and HS — Only 2 transitions per 130 clock cycles are transmitted, the transition pulse must be 3 PCLK or longer.
- Normal Mode with Control Signal Filter Disabled: DE and HS — Only 2 transitions per 130 clock cycles are transmitted, no restriction on minimum transition pulse.
- VS — Only 1 transition per 130 clock cycles are transmitted, minimum pulse width is 130 clock cycles.

Video Control Signals are defined as low frequency signals with limited transitions. Glitches of a control signal can cause a visual display error. This feature allows for the chipset to validate and filter out any high frequency noise on the control signals. See [Figure 14](#).

Feature Description (continued)

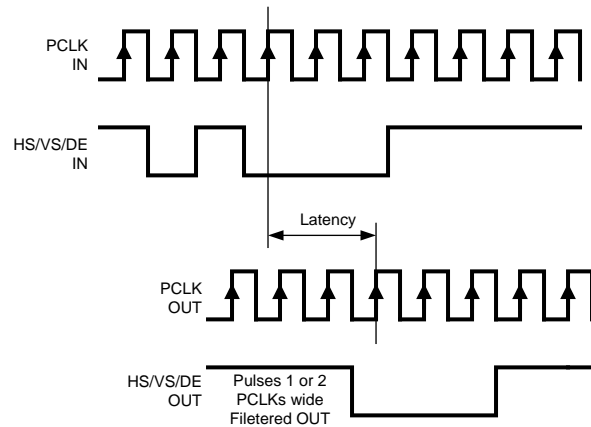

Figure 14. Video Control Signal Filter Waveform

7.3.5 EMI Reduction Features

7.3.5.1 Input SSC Tolerance (SSCT)

The DS90UB921-Q1 serializer is capable of tracking a triangular input spread spectrum clocking (SSC) profile up to $\pm 2.5\%$ amplitude deviations (center spread), up to 35 kHz modulation at 5–96 MHz, from a host source.

7.3.6 LVCMOS VDDIO Option

1.8 V or 3.3 V Inputs and Outputs are powered from a separate VDDIO supply to offer compatibility with external system interface signals.

NOTE

When configuring the VDDIO power supplies, all the single-ended data and control input pins for device need to scale together with the same operating VDDIO levels.

7.3.7 Power Down (PDB)

The Serializer has a PDB input pin to ENABLE or POWER DOWN the device. This pin can be controlled by the host or through the VDDIO, where VDDIO = 3.0V to 3.6V or VDD33. To save power disable the link when the display is not needed (PDB = LOW). When the pin is driven by the host, make sure to release it after VDD33 and VDDIO have reached final levels; no external components are required. In the case of driven by the VDDIO = 3.0V to 3.6V or VDD33 directly, a 10 kohm resistor to the VDDIO = 3.0V to 3.6V or VDD33, and a >10uF capacitor to the ground are required (See [Figure 26](#)).

7.3.8 Remote Auto Power-Down Mode

The DS90UB921-Q1 serializer features a Remote Auto Power Down mode. This feature is enabled and disabled through the register bit 0x01[7] ([Table 7](#)). When the back channel is not detected, either due to an idle or powered-down deserializer, the serializer enters remote auto power down mode. Power dissipation of the serializer is significantly reduced in this mode. The serializer automatically attempts to resume normal operation upon detection of an active back channel from the deserializer. To complete the wake-up process and reactivate forward channel operation, the remote power-down feature must be disabled by either a local I²C host, or by an auto-ACK I²C transaction from a remote I²C host located at the deserializer. The Remote Auto Power Down Sleep/Wake cycle is shown below in [Figure 15](#):

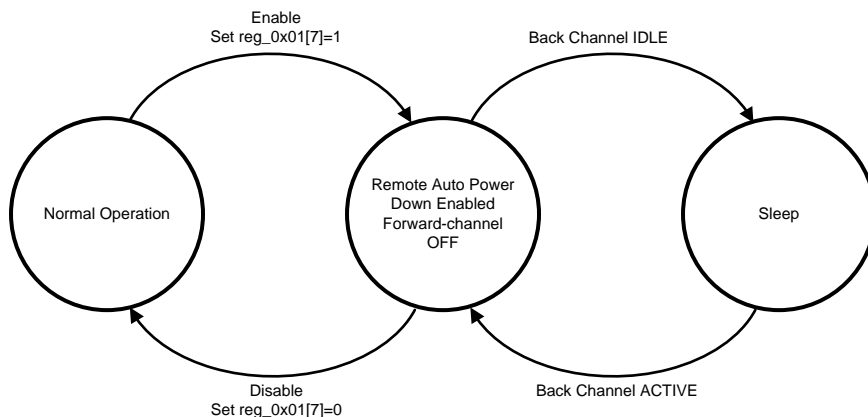
Feature Description (continued)

Figure 15. Remote Auto Power Down Sleep/Wake Cycle

To resume normal operation, the Remote Auto Power Down feature must be disabled in the device control register. This may be accomplished from a local I²C controller by writing reg_0x01[7]=0 (Table 7). To disable from a remote I²C controller located at the deserializer, perform the following procedure to complete the wake-up process:

1. Power up remote deserializer (back channel must be active)
2. Enable I²C PASS-THROUGH ALL by setting deserializer register reg_0x05[7]=1
3. Enable I²C AUTO ACK by setting deserializer register reg_0x03[2]=1
4. Disable Remote Auto Power Down by setting serializer register reg_0x01[7]=0
5. Disable I²C AUTO ACK by setting deserializer register reg_0x03[2]=0
6. Disable I²C PASS-THROUGH ALL by setting deserializer register reg_0x05[7]=0

7.3.9 Input PCLK Loss Detect

The serializer can be programmed to enter a low power SLEEP state when the input clock (PCLK) is lost. This is done via register 0x03[1] (see Table 7). A clock loss condition is detected when PCLK drops below approximately 1MHz. When a PCLK is detected again, the serializer will then lock to the incoming PCLK. Note – when PCLK is lost, the Serial Control Bus Registers values are still RETAINED.

Feature Description (continued)

7.3.10 Serial Link Fault Detect

The serial link fault detection is able to detect any of following seven (7) conditions:

1. cable open
2. “+” to “-” short
3. “+” short to GND
4. “-” short to GND
5. “+” short to battery
6. “-” short to battery
7. Cable is linked correctly

If any one of the fault conditions (first 6 conditions above) occurs, The Link Detect Status is 0 (cable is not detected) on bit 0 of address 0x0C [Table 7](#).

7.3.11 Pixel Clock Edge Select (TRFB)

The TRFB control register bit selects which edge of the Pixel Clock is used. For the serializer, this pin determines the edge that the data is latched on. If TRFB is HIGH ('1'), data is latched on the Rising edge of the PCLK. If TRFB is LOW ('0'), data is latched on the Falling edge of the PCLK.

7.3.12 Frequency Mode Optimizations

HFMODE, LFMODE, and IFMODE are set through a combination of the FSEL pin and MODE_SEL pin, with register overrides for both. These pins (or register overrides) will configure the DS90UB921-Q1 into either Low Frequency Mode (LFMODE), Intermediate Frequency mode (IFMODE), or High Frequency mode (HFMODE). See [Table 1](#) for details on how each mode is enabled.

Table 1. HFMODE / LFMODE / IFMODE Configuration Table

FSEL (pin 15, or register 0x35[7:6])	ALTERNATE FREQUENCY (set by MODE_SEL pin, or register 0x04[1:0])	MODE	PCLK RANGE for COAX	PCLK RANGE for STP
L	L	HFMODE	N/A	15 - 96 MHz
H	L	HFMODE	48 - 96 MHz	N/A
H	H	IFMODE	24 - 48 MHz	N/A
L	H	LFMODE	15 - 24 MHz	5 - 15 MHz

7.3.13 Interrupt Pins – Functional Description and Usage (INTB, REM_INTB)

The REM_INTB pin mirrors the status of INTB_IN from the remote deserializer. Any change in INTB_IN status of the remote device will be reflected at the REM_INTB output of the serializer. REM_INTB will remain LOW until lock is achieved with the downstream deserializer. Alternately, the INTB pin can be set to trigger on remote interrupts by following the steps below.

1. On DS90UB921-Q1, read register 0xC7.
2. On DS90UB921-Q1, set register 0xC6[5] = 1 and 0xC6[0] = 1
3. Deserializer INTB_IN is set LOW by some downstream device.
4. DS90UB921-Q1 serializer pulls INTB (pin 31) LOW. The signal is active low, so a LOW indicates an interrupt condition.
5. External controller detects INTB = LOW; to determine interrupt source, read ISR register 0xC7.
6. A read to ISR will clear the interrupt at the DS90UB921-Q1, releasing INTB.
7. The external controller typically must then access the remote device to determine downstream interrupt source and clear the interrupt driving INTB_IN. This would be when the downstream device releases the INTB_IN on the deserializer. The system is now ready to return to step (1) at next falling edge of INTB_IN.

If using the REM_INTB pin instead of INTB for remote interrupts, the IS_RX_INT bit (0xC6[5]) of the serializer's ICR register must be set low (default) masking remote interrupts to the INTB pin.

7.3.14 Internal Pattern Generation

The DS90UB921-Q1 serializer supports the internal pattern generation feature. It allows basic testing and debugging of an integrated panel through the FPD-Link III output stream. The test patterns are simple and repetitive and allow for a quick visual verification of panel operation. As long as the device is not in power down mode, the test pattern will be displayed even if no parallel input is applied. If no PCLK is received, the test pattern can be configured to use a programmed oscillator frequency. For detailed information, refer to Application Note AN-2198 (SNLA132).

7.3.15 GPIO[3:0] and GPO_REG[7:4]

In 18-bit RGB operation mode, the optional R[1:0] and G[1:0] of the DS90UB921-Q1 can be used as the general purpose IOs GPIO[3:0] in either forward channel (Inputs) or back channel (Outputs) applications.

7.3.15.1 GPIO[3:0] Enable Sequence

See [Table 2](#) for the GPIO enable sequencing.

Step 1: Enable the 18-bit mode either through the configuration register bit [Table 7](#) on DS90UB921-Q1 only. The deserializer is automatically configured as in the 18-bit mode.

Step 2: To enable GPIO3 forward channel, write 0x03 to address 0x0F on DS90UB921-Q1, then write 0x05 to address 0x1F on the deserializer.

Table 2. GPIO Enable Sequencing Table

#	DESCRIPTION	DEVICE	FORWARD CHANNEL	BACK CHANNEL
1	Enable 18-bit mode	DS90UB921-Q1	0x12 = 0x04	0x12 = 0x04
		DS90UB926Q-Q1	Auto Load from DS90UB921-Q1	Auto Load from DS90UB921-Q1
2	GPIO3	DS90UB921-Q1	0x0F = 0x03	0x0F = 0x05
		DS90UB926Q-Q1	0x1F = 0x05	0x1F = 0x03
3	GPIO2	DS90UB921-Q1	0x0E = 0x30	0x0E = 0x50
		DS90UB926Q-Q1	0x1E = 0x50	0x1E = 0x30
4	GPIO1	DS90UB921-Q1	0x0E = 0x03	0x0E = 0x05
		DS90UB926Q-Q1	0x1E = 0x05	0x1E = 0x03
5	GPIO0	DS90UB921-Q1	0x0D = 0x93	0x0D = 0x95
		DS90UB926Q-Q1	0x1D = 0x95	0x1D = 0x93

Note: GPO_REG4 of the DS90UB921-Q1 can be used as a forward channel GPIO, outputting on GPIO0 of DS90UB928Q-Q1. This is configured as follows:

- Set DS90UB921-Q1 in 18-bit mode by register 0x12[2] = 1.
- Set DS90UB928Q-Q1 register 0x1D[0] = 1 and 0x1D[2] = 1; this enables GPIO0 of DS90UB928Q-Q1 as an output.
- Set DS90UB921-Q1 register 0x0F[4] = 1 and 0x0F[5] = 1; this enables GPO_REG4 of DS90UB921-Q1 as an input.

Similarly GPO_REG5 of DS90UB921-Q1 can output to GPIO1 of DS90UB928Q-Q1:

- Set DS90UB921-Q1 in 18-bit mode by register 0x12[2] = 1.
- Set DS90UB928Q-Q1 register 0x1E[0] = 1 and 0x1E[2] = 1; this enables GPIO1 of DS90UB928Q-Q1 as an output.
- Set DS90UB921-Q1 register 0x10[0] = 1 and 0x10[1] = 1; this enables GPO_REG5 DS90UB921-Q1 as an input.

7.3.15.2 GPO_REG[7:4] Enable Sequence

GPO_REG[7:4] are the outputs only pins. They must be programmed through the local register bits. See [Table 3](#) for the GPO_REG enable sequencing.

Step 1: Enable the 18-bit mode either through the configuration register bit [Table 7](#) on DS90UB921-Q1 only. The deserializer is automatically configured as in the 18-bit mode.

Step 2: To enable GPO_REG7 outputs an “1”, write 0x09 to address 0x11 on DS90UB921-Q1.

Table 3. GPO_REG Enable Sequencing Table

#	DESCRIPTION	DEVICE	LOCAL ACCESS	LOCAL OUTPUT
1	Enable 18-bit mode	DS90UB921-Q1	0x12 = 0x04	
2	GPO_REG7	DS90UB921-Q1	0x11 = 0x09	“1”
			0x11 = 0x01	“0”
3	GPO_REG6	DS90UB921-Q1	0x10 = 0x90	“1”
			0x10 = 0x10	“0”
4	GPO_REG5	DS90UB921-Q1	0x10 = 0x09	“1”
			0x10 = 0x01	“0”
5	GPO_REG4	DS90UB921-Q1	0x0F = 0x90	“1”
			0x0F = 0x10	“0”

7.3.16 I2S Transmitting

In normal 24-bit RGB operation mode, the DS90UB921-Q1 supports 3 bits of I2S. They are I2S_CLK, I2S_WC and I2S_DA. The optionally packetized audio information can be transmitted during the video blanking (data island transport) or during active video (forward channel frame transport). Note: The bit rates of any I2S bits must maintain one fourth of the PCLK rate. [Table 4](#) covers the range of I2S sample rates.

Table 4. Audio Interface Frequencies

SAMPLE RATE (kHz)	I2S DATA WORD SIZE (BITS)	I2S CLK (MHz)
32	16	1.024
44.1	16	1.411
48	16	1.536
96	16	3.072
192	16	6.144
32	24	1.536
44.1	24	2.117
48	24	2.304
96	24	4.608

Table 4. Audio Interface Frequencies (continued)

SAMPLE RATE (kHz)	I2S DATA WORD SIZE (BITS)	I2S CLK (MHz)
192	24	9.216
32	32	2.048
44.1	32	2.822
48	32	3.072
96	32	6.144
192	32	12.288

7.3.17 Built In Self Test (BIST)

An optional At-Speed Built In Self Test (BIST) feature supports the testing of the high speed serial link and the low-speed back channel. This is useful in the prototype stage, equipment production, in-system test and also for system diagnostics.

7.3.17.1 BIST Configuration and Status

The BIST mode is enabled at the deserializer by the Pin select (BISTEN and BISTC) or configuration register (Table 7) through the deserializer. When LFMODE = 0, the pin based configuration defaults to external PCLK or 33 MHz internal Oscillator clock (OSC) frequency. In the absence of PCLK, the user can select the desired OSC frequency (default 33 MHz or 25MHz) through the register bit. When LFMODE = 1, the pin based configuration defaults to external PCLK or 12.5MHz internal Oscillator clock (OSC) frequency.

When BISTEN of the deserializer is high, the BIST mode enable information is sent to the serializer through the Back Channel. The serializer outputs a test pattern and drives the link at speed. The deserializer detects the test pattern and monitors it for errors. The PASS output pin toggles to flag any payloads that are received with 1 to 35 bit errors.

The BIST status is monitored real time on PASS pin. The result of the test is held on the PASS output until reset (new BIST test or Power Down). A high on PASS indicates NO ERRORS were detected. A Low on PASS indicates one or more errors were detected. The duration of the test is controlled by the pulse width applied to the deserializer BISTEN pin. This BIST feature also contains a Link Error Count and a Lock Status. If the connection of the serial link is broken, then the link error count is shown in the register. When the PLL of the deserializer is locked or unlocked, the lock status can be read in the register. See Table 7.

7.3.17.1.1 Sample BIST Sequence

See Figure 16 for the BIST mode flow diagram.

Step 1: BIST Mode is enabled via the BISTEN pin of the deserializer. The desired clock source is selected through BISTC pin.

Step 2: The DS90UB921-Q1 serializer is woken up through the back channel if it is not already on. The all zero pattern on the data pins is sent through the FPD-Link III to the deserializer. Once the serializer and the deserializer are in BIST mode and the deserializer acquires Lock, the PASS pin of the deserializer goes high and BIST starts checking the data stream. If an error in the payload (1 to 35) is detected, the PASS pin will switch low for one half of the clock period. During the BIST test, the PASS output can be monitored and counted to determine the payload error rate.

Step 3: To Stop the BIST mode, the deserializer BISTEN pin is set Low. The deserializer stops checking the data. The final test result is held on the PASS pin. If the test ran error free, the PASS output will be High. If there was one or more errors detected, the PASS output will be Low. The PASS output state is held until a new BIST is run, the device is RESET, or Powered Down. The BIST duration is user controlled by the duration of the BISTEN signal.

Step 4: The Link returns to normal operation after the deserializer BISTEN pin is low. Figure 17 shows the waveform diagram of a typical BIST test for two cases. Case 1 is error free, and Case 2 shows one with multiple errors. In most cases it is difficult to generate errors due to the robustness of the link (differential data transmission etc.), thus they may be introduced by greatly extending the cable length, faulting the interconnect, reducing signal condition enhancements (Rx Equalization).

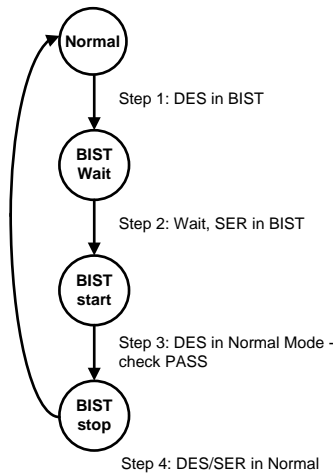

Figure 16. Bist Mode Flow Diagram

7.3.17.2 Forward Channel And Back Channel Error Checking

While in BIST mode, the serializer stops sampling RGB input pins and switches over to an internal all-zero pattern. The internal all-zeroes pattern goes through scrambler, dc-balancing etc. and goes over the serial link to the deserializer. The deserializer on locking to the serial stream compares the recovered serial stream with all-zeroes and records any errors in status registers and dynamically indicates the status on PASS pin. The deserializer then outputs a simultaneous switching output (SSO) pattern on the RGB output pins.

The back-channel data is checked for CRC errors once the serializer locks onto back-channel serial stream as indicated by link detect status (register bit 0x0C[0]). The CRC errors are recorded in an 8-bit register. The register is cleared when the serializer enters the BIST mode. As soon as the serializer exits BIST mode, the functional mode CRC register starts recording the CRC errors. The BIST mode CRC error register is active in BIST mode only and keeps the record of last BIST run until cleared or enters BIST mode again.

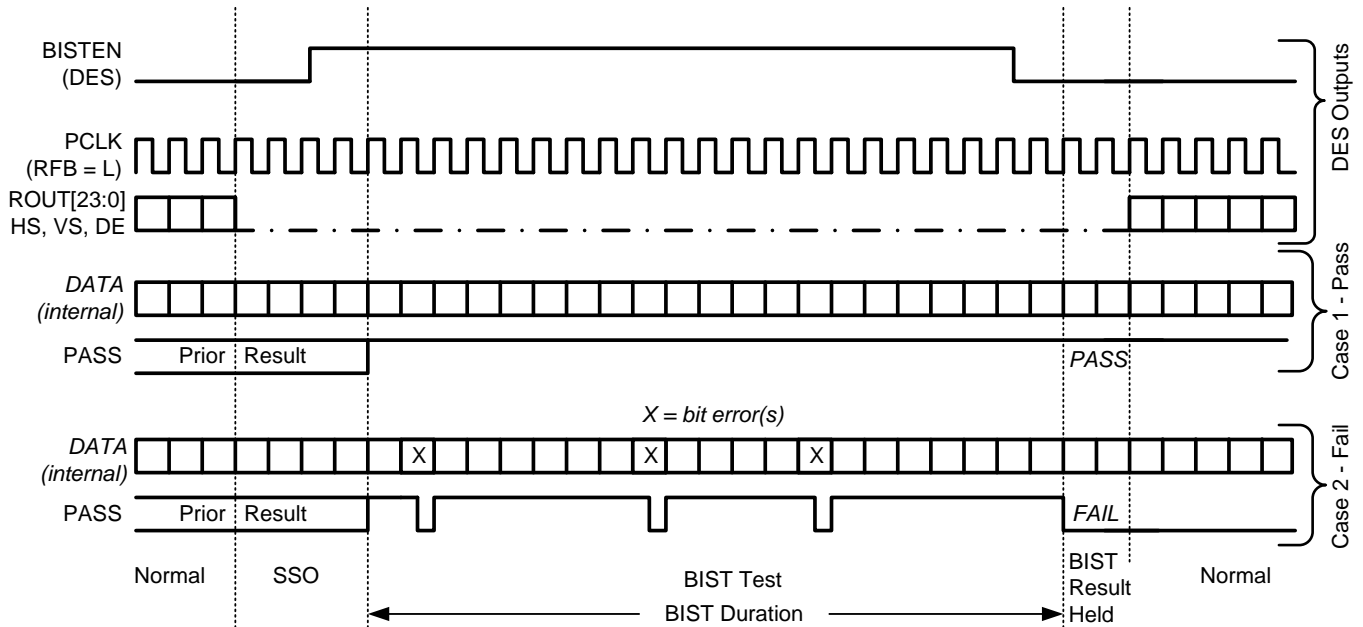

Figure 17. Bist Waveforms

7.4 Device Functional Modes

7.4.1 Configuration Select (MODE_SEL)

Configuration of the device may be done via the MODE_SEL input pin, or via the configuration register bit. A pull-up resistor and a pull-down resistor of suggested values may be used to set the voltage ratio of the MODE_SEL input (V_{R4}) and VDD33 to select one of the other 7 possible selected modes. The voltage range in between the Minimum and Maximum V_{R4} must be adhered even when taking resistor tolerances into account. The 1% suggested resistors meet this for all cases, but others that also meet the desired voltage range are also acceptable. See [Figure 18](#) and [Table 5](#).

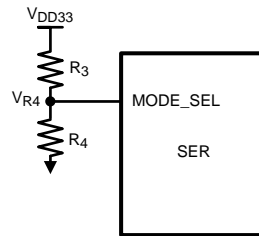

Figure 18. MODE_SEL Connection Diagram

Table 5. Configuration Select (MODE_SEL)

#	MINIMUM V_{R4} (V) ⁽¹⁾	MAXIMUM V_{R4} (V) ⁽¹⁾	SUGGESTED RESISTOR R3 kΩ (1% tol)	SUGGESTED RESISTOR R4 kΩ (1% tol)	ALTERNATE FREQUENCY	REPEATER	18-BIT MODE
1	0.000	0.150	Open	40.2 or Any	L	L	L
2	0.530	0.596	90.9	18.7	L	H	L
3	0.725	0.800	93.1	28.0	L	H	H
4	0.930	1.012	71.5	30.1	H	L	L
5	1.165	1.284	68.1	40.2	H	L	H
6	1.480	1.599	82.5	71.5	H	H	L
7	1.750	1.905	73.2	90.9	H	H	H

Alternate Frequency:
See [Frequency Mode Optimizations](#)

Repeater:
L = Repeater OFF (Default)
H = Repeater ON

18-bit Mode:
L = Normal 24-bit RGB Mode (Default)
H = 18-bit RGB Mode. Note: use of GPIO(s) on unused inputs must be enabled by register.

7.4.2 Repeater Application

The DS90UB921-Q1 and DS90UB926Q-Q1 can be configured to extend data transmission over multiple links to multiple display devices. Setting the devices into repeater mode provides a mechanism for transmitting to all receivers in the system.

7.4.2.1 Repeater Configuration

In the repeater application, in this document, the DS90UB921-Q1 is referred to as the Transmitter or transmit port (TX), and the DS90UB926Q-Q1 is referred to as the Receiver (RX). [Figure 19](#) shows the maximum configuration supported for Repeater implementations using the DS90UB921-Q1 (TX) and DS90UB926Q-Q1 (RX). Two levels of Repeaters are supported with a maximum of three Transmitters per Receiver.

(1) Voltage indicated assumes nominal VDD33.

Device Functional Modes (continued)

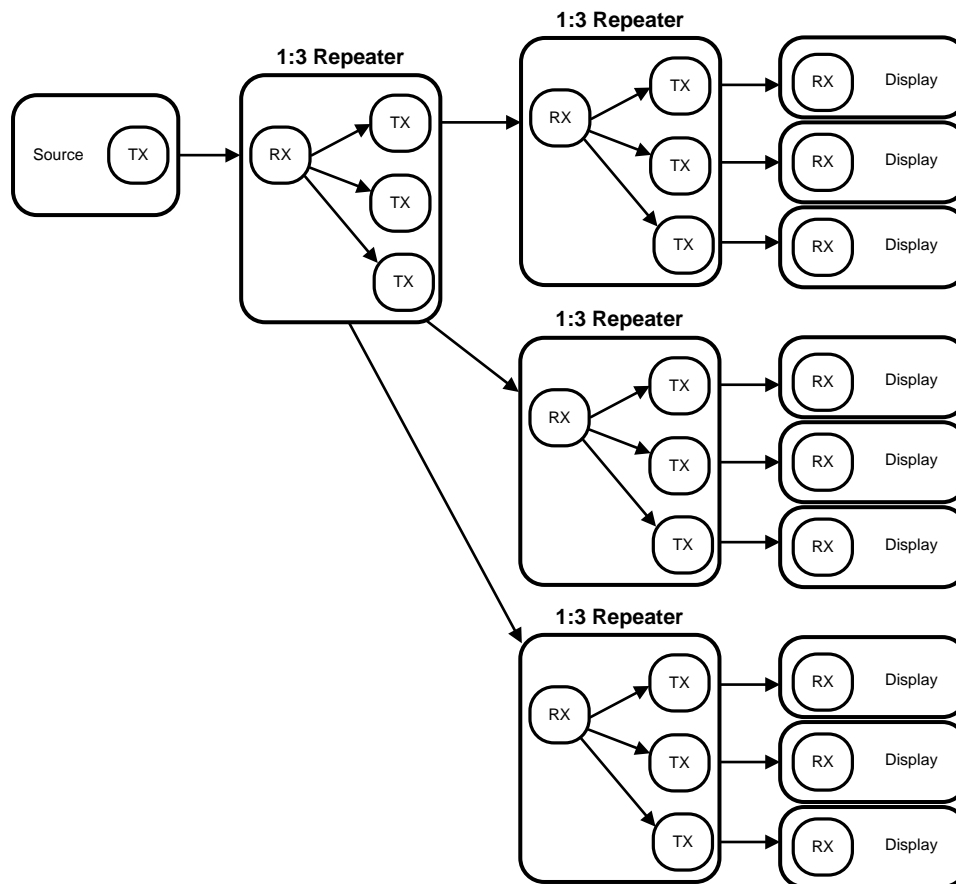

Figure 19. Maximum Repeater Application

In a repeater application, the I2C interface at each TX and RX may be configured to transparently pass I2C communications upstream or downstream to any I2C device within the system. This includes a mechanism for assigning alternate IDs (Slave Aliases) to downstream devices in the case of duplicate addresses.

At each repeater node, the parallel LVCMOS interface fans out to up to three serializer devices, providing parallel RGB video data, HS/VS/DE control signals and, optionally, packetized audio data (transported during video blanking intervals). Alternatively, the I2S audio interface may be used to transport digital audio data between receiver and transmitters in place of packetized audio. All audio and video data is transmitted at the output of the Receiver and is received by the Transmitter.

Figure 20 provides more detailed block diagram of a 1:2 repeater configuration.

Device Functional Modes (continued)

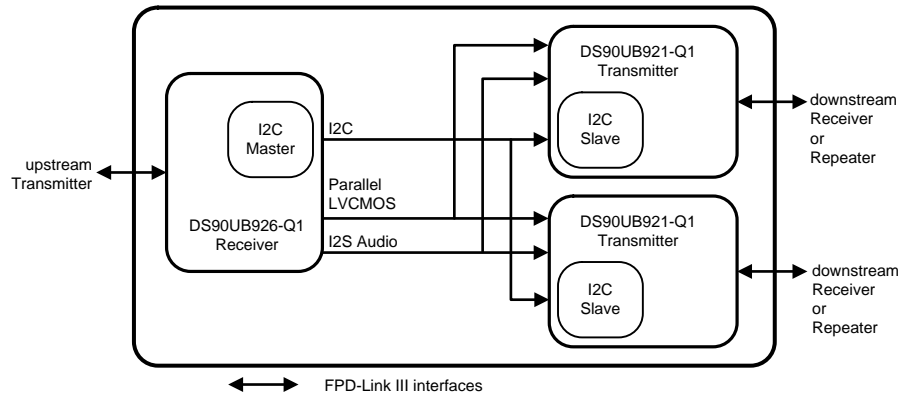

Figure 20. 1:2 Repeater Configuration

7.4.2.2 Repeater Connections

The Repeater requires the following connections between the Receiver and each Transmitter [Figure 21](#).

1. Video Data – Connect PCLK, RGB and control signals (DE, VS, HS).
2. I2C – Connect SCL and SDA signals. Both signals should be pulled up to VDD33 with 4.7 kΩ resistors.
3. Audio – Connect I2S_CLK, I2S_WC, and I2S_DA signals.
4. IDx pin – Each Transmitter and Receiver must have a unique I2C address.
5. MODE_SEL pin – All Transmitter and Receiver must be set into the Repeater Mode.
6. Interrupt pin – Connect DS90UB926Q-Q1 INTB_IN pin to DS90UB921-Q1 INTB pin. The signal must be pulled up to VDDIO.

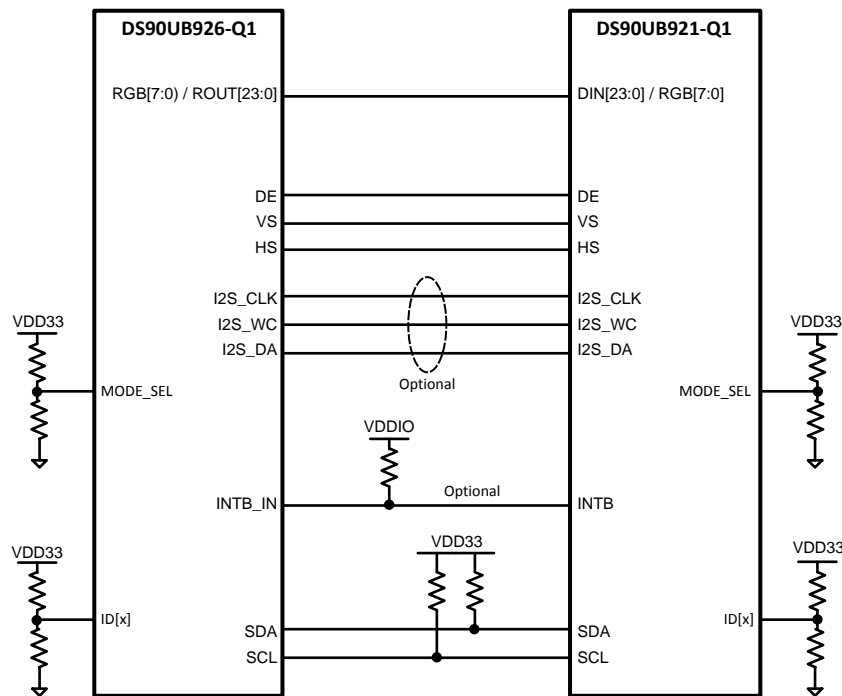

Figure 21. Repeater Connection Diagram

7.5 Programming

The DS90UB921-Q1 is configured by the use of a serial control bus that is I2C protocol compatible. Multiple serializer devices may share the serial control bus since 9 device addresses are supported. Device address is set via R_1 and R_2 values on IDx pin. See [Figure 22](#).

The serial control bus consists of two signals and a configuration pin. The SCL is a Serial Bus Clock Input / Output. The SDA is the Serial Bus Data Input / Output signal. Both SCL and SDA signals require an external pull-up resistor to VDD33. For most applications a 4.7 k pull-up resistor to VDD33 may be used. The resistor value may be adjusted for capacitive loading and data rate requirements. The signals are either pulled High, or driven Low.

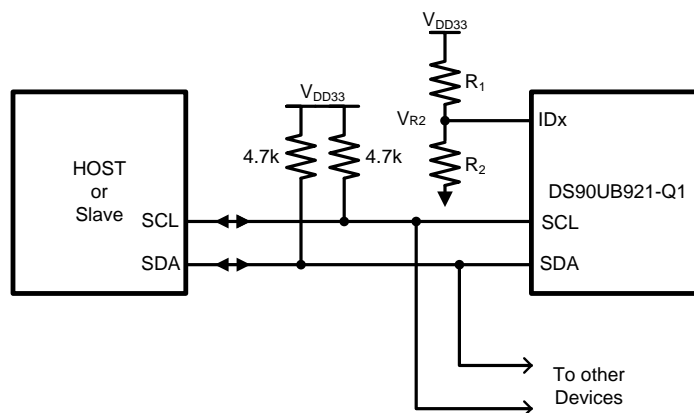

Figure 22. Serial Control Bus Connection

The configuration pin is the IDx pin. This pin sets one of 8 possible device addresses. A pull-up resistor and a pull-down resistor of suggested values may be used to set the voltage ratio of the IDx input (V_{R2}) and VDD33 to select one of the other 8 possible addresses. The voltage range in between the Minimum and Maximum V_{R2} must be adhered even when taking resistor tolerances into account. The 1% suggested resistors meet this for all cases, but others that also meet the desired voltage range are also acceptable. See [Table 6](#).

Table 6. Serial Control Bus Addresses for IDx

#	Minimum Voltage V_{R2} (V) ⁽¹⁾	Maximum Voltage V_{R2} (V) ⁽¹⁾	Suggested Resistor R_1 k Ω (1% tol)	Suggested Resistor R_2 k Ω (1% tol)	Address 7'b	Address 8'b Appended
1	0.000	0.150	Open	40.2 or Any	0x0C	0x18
2	0.535	0.578	86.6	17.4	0x0E	0x1C
3	0.723	0.775	90.9	26.7	0x10	0x20
4	0.947	0.995	71.5	30.1	0x12	0x24
5	1.203	1.258	84.5	49.9	0x14	0x28
6	1.493	1.565	54.9	47.5	0x16	0x2C
7	1.789	1.855	78.7	97.6	0x18	0x30
8	2.469	2.515	30.9	95.3	0x1A	0x34

(1) Voltage indicated assumes nominal VDD33.

The Serial Bus protocol is controlled by START, START-Repeated, and STOP phases. A START occurs when SCL transitions Low while SDA is High. A STOP occurs when SDA transition High while SCL is also HIGH. See [Figure 23](#).

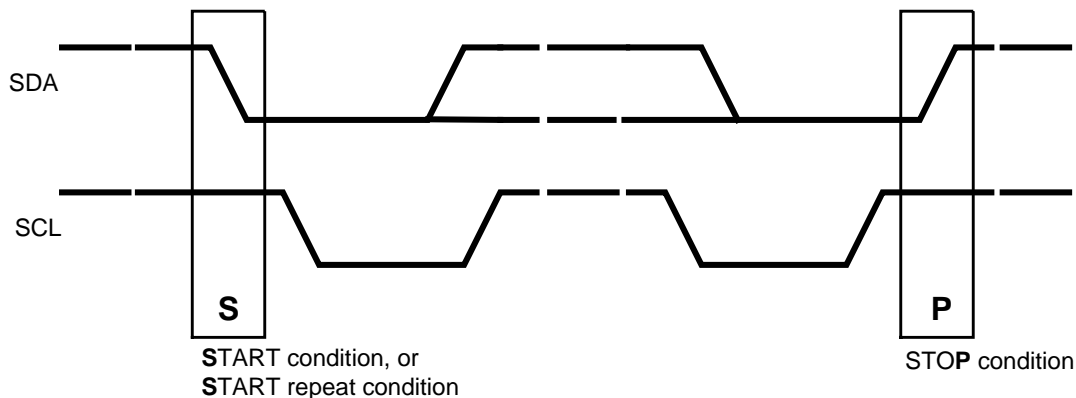

Figure 23. Start and Stop Conditions

To communicate with a remote device, the host controller (master) sends the slave address and listens for a response from the slave. This response is referred to as an acknowledge bit (ACK). If a slave on the bus is addressed correctly, it Acknowledges (ACKs) the master by driving the SDA bus low. If the address doesn't match a device's slave address, it Not-acknowledges (NACKs) the master by letting SDA be pulled High. ACKs also occur on the bus when data is being transmitted. When the master is writing data, the slave ACKs after every data byte is successfully received. When the master is reading data, the master ACKs after every data byte is received to let the slave know it wants to receive another data byte. When the master wants to stop reading, it NACKs after the last data byte and creates a stop condition on the bus. All communication on the bus begins with either a Start condition or a Repeated Start condition. All communication on the bus ends with a Stop condition. A READ is shown in [Figure 24](#) and a WRITE is shown in [Figure 25](#).

If the Serial Bus is not required, the three pins may be left open (NC).

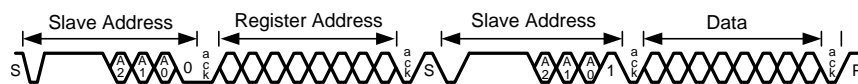

Figure 24. Serial Control Bus — Read

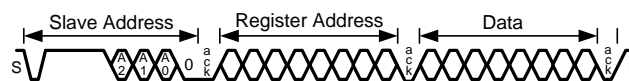

Figure 25. Serial Control Bus — Write

7.6 Register Maps

Table 7. Serial Control Bus Registers

ADD (dec)	ADD (hex)	REGISTER NAME	BIT(S)	TYPE	DEFAULT (hex)	FUNCTION	DESCRIPTION
0	0x00	I2C Device ID	7:1	RW		Device ID	7-bit address of Serializer
			0	RW		ID Setting	I2C ID Setting 1: Register I2C Device ID (Overrides IDx pin) 0: Device ID is from IDx pin
1	0x01	Reset	7	RW	0x00	Soft Sleep	1: Enable power down when no Bidirectional Control Channel Link detected. 0: Do not power down when no Bidirectional Control Channel Link detected.
			6:2				Reserved
			1	RW		Digital RESET1	Reset the entire digital block including registers This bit is self-clearing. 1: Reset 0: Normal operation
			0	RW		Digital RESET0	Reset the entire digital block except registers This bit is self-clearing 1: Reset 0: Normal operation
3	0x03	Configuration [0]	7	RW	0xD2	Back channel CRC Checker Enable	Back Channel Check Enable 1: Enable 0: Disable
			6				Reserved
			5	RW		I2C Remote Write Auto Acknowledge	Automatically Acknowledge I2C Remote Write When enabled, I2C writes to the Deserializer (or any remote I2C Slave, if I2C PASS ALL is enabled) are immediately acknowledged without waiting for the Deserializer to acknowledge the write. This allows higher throughput on the I2C bus 1: Enable 0: Disable
			4	RW		Filter Enable	HS, VS, DE two clock filter When enabled, pulses less than two full PCLK cycles on the DE, HS, and VS inputs will be rejected 1: Filtering enable 0: Filtering disable
			3	RW		I2C Pass-through	I2C Pass-Through Mode 1: Pass-Through Enabled 0: Pass-Through Disabled
			2				Reserved
			1	RW		PCLK Auto	Switch over to internal OSC in the absence of PCLK 1: Enable auto-switch 0: Disable auto-switch
			0	RW		TRFB	Pixel Clock Edge Select 1: Parallel Interface Data is strobed on the Rising Clock Edge. 0: Parallel Interface Data is strobed on the Falling Clock Edge.

Table 7. Serial Control Bus Registers (continued)

ADD (dec)	ADD (hex)	REGISTER NAME	BIT(S)	TYPE	DEFAULT (hex)	FUNCTION	DESCRIPTION
4	0x04	Configuration [1]	7	RW	0x80	Failsafe State	Input Failsafe State 1: Failsafe to Low 0: Failsafe to High
			6				Reserved
			5	RW		CRC Error Reset	Clear back channel CRC Error Counters This bit is NOT self-clearing 1: Clear Counters 0: Normal Operation
			4			RGB DE Gate	1: Gate RGB data with DE 0: Pass RGB data independent of DE (default) This bit is recommended to be set to 1 to avoid unintentionally entering AVMUTE mode. See AVMUTE Operation .
			3:2	RW		Reserved	Reserved
			1	RW		ALTERNATE FREQUENCY select by pin or register control	Frequency range is set by MODE_SEL pin or register, in conjunction with FSEL pin or register 0x35[7:6]. See Frequency Mode Optimizations . 1: Frequency range is set by register. Use register bit reg_0x04[0] to set Alternate Frequency. 0: Frequency range is set by MODE_SEL pin.
			0	RW		ALTERNATE FREQUENCY Override Value	Frequency range select, in conjunction with FSEL pin or register 0x35[7:6]. See Frequency Mode Optimizations .

Table 7. Serial Control Bus Registers (continued)

ADD (dec)	ADD (hex)	REGISTER NAME	BIT(S)	TYPE	DEFAULT (hex)	FUNCTION	DESCRIPTION
5	0x05	I2C Control	7:5		0x00		Reserved
			4:3	RW		SDA Output Delay	SDA output delay Configures output delay on the SDA output. Setting this value will increase output delay in units of 40ns. Nominal output delay values for SCL to SDA are 00: 240ns 01: 280ns 10: 320ns 11: 360ns
			2	RW		Local Write Disable	Disable remote writes to local registers Setting the bit to a 1 prevents remote writes to local device registers from across the control channel. It prevents writes to the Serializer registers from an I2C master attached to the Deserializer. Setting this bit does not affect remote access to I2C slaves at the Serializer
			1	RW		I2C Bus Timer Speedup	Speed up I2C bus watchdog timer 1: Watchdog timer expires after ~50 ms. 0: Watchdog Timer expires after ~1 s
			0	RW		I2C Bus timer Disable	Disable I2C bus watchdog timer When the I2C watchdog timer may be used to detect when the I2C bus is free or hung up following an invalid termination of a transaction. If SDA is high and no signalling occurs for ~1 s, the I2C bus assumes to be free. If SDA is low and no signaling occurs, the device attempts to clear the bus by driving 9 clocks on SCL
6	0x06	DES ID	7:1	RW	0x00	DES Device ID	7-bit Deserializer Device ID Configures the I2C Slave ID of the remote Deserializer. A value of 0 in this field disables I2C access to the remote Deserializer. This field is automatically configured by the Bidirectional Control Channel once RX Lock has been detected. Software may overwrite this value, but should also assert the FREEZE DEVICE ID bit to prevent overwriting by the Bidirectional Control Channel.
			0	RW		Device ID Frozen	Freeze Deserializer Device ID Prevents autoloading of the Deserializer Device ID by the Bidirectional Control Channel. The ID will be frozen at the value written.
7	0x07	Slave ID	7:1	RW	0x00	Slave Device ID	7-bit Remote Slave Device ID Configures the physical I2C address of the remote I2C Slave device attached to the remote Deserializer. If an I2C transaction is addressed to the Slave Device Alias ID, the transaction will be remapped to this address before passing the transaction across the Bidirectional Control Channel to the Deserializer
			0				Reserved

Table 7. Serial Control Bus Registers (continued)

ADD (dec)	ADD (hex)	REGISTER NAME	BIT(S)	TYPE	DEFAULT (hex)	FUNCTION	DESCRIPTION
8	0x08	Slave Alias	7:1	RW	0x00	Slave Device Alias ID	7-bit Remote Slave Device Alias ID Assigns an Alias ID to an I2C Slave device attached to the remote Deserializer. The transaction will be remapped to the address specified in the Slave ID register. A value of 0 in this field disables access to the remote I2C Slave.
			0				Reserved
10	0x0A	CRC Errors	7:0	R	0x00	CRC Error LSB	Number of back channel CRC errors – 8 least significant bits
11	0x0B		7:0	R	0x00	CRC Error MSB	Number of back channel CRC errors – 8 most significant bits
12	0x0C	General Status	7:4		0x00		Reserved
			3	R		BIST CRC Error	Back channel CRC error during BIST communication with Deserializer. The bit is cleared upon loss of link, restart of BIST, or assertion of CRC ERROR RESET in register 0x04.
			2	R		PCLK Detect	PCLK Status 1: Valid PCLK detected 0: Valid PCLK not detected
			1	R		DES Error	Back channel CRC error during communication with Deserializer. The bit is cleared upon loss of link or assertion of CRC ERROR RESET in register 0x04.
			0	R		LINK Detect	LINK Status 1: Cable link detected 0: Cable link not detected (Fault Condition)
13	0x0D	GPIO0 Configuration	7:4	R	0x00	RESERVED	Reserved
			3	RW		GPIO0 Output Value	Local GPIO output value This value is output on the GPIO pin when the GPIO function is enabled, the local GPIO direction is Output, and remote GPIO control is disabled.
			2	RW		GPIO0 Remote Enable	Remote GPIO control 1: Enable GPIO control from remote Deserializer. The GPIO pin will be an output, and the value is received from the remote Deserializer. 0: Disable GPIO control from remote Deserializer.
			1	RW		GPIO0 Direction	Local GPIO Direction 1: Input 0: Output
			0	RW		GPIO0 Enable	GPIO function enable 1: Enable GPIO operation 0: Enable normal operation

Table 7. Serial Control Bus Registers (continued)

ADD (dec)	ADD (hex)	REGISTER NAME	BIT(S)	TYPE	DEFAULT (hex)	FUNCTION	DESCRIPTION
14	0x0E	GPIO2 and GPIO1 Configurations	7	RW	0x00	GPIO2 Output Value	Local GPIO output value This value is output on the GPIO pin when the GPIO function is enabled, the local GPIO direction is Output, and remote GPIO control is disabled.
			6	RW		GPIO2 Remote Enable	Remote GPIO control 1: Enable GPIO control from remote Deserializer. The GPIO pin will be an output, and the value is received from the remote Deserializer. 0: Disable GPIO control from remote Deserializer.
			5	RW		GPIO2 Direction	Local GPIO Direction 1: Input 0: Output
			4	RW		GPIO2 Enable	GPIO function enable 1: Enable GPIO operation 0: Enable normal operation
			3	RW		GPIO1 Output Value	Local GPIO output value This value is output on the GPIO pin when the GPIO function is enabled, the local GPIO direction is Output, and remote GPIO control is disabled.
			2	RW		GPIO1 Remote Enable	Remote GPIO control 1: Enable GPIO control from remote Deserializer. The GPIO pin will be an output, and the value is received from the remote Deserializer. 0: Disable GPIO control from remote Deserializer.
			1	RW		GPIO1 Direction	Local GPIO Direction 1: Input 0: Output
			0	RW		GPIO1 Enable	GPIO function enable 1: Enable GPIO operation 0: Enable normal operation

Table 7. Serial Control Bus Registers (continued)

ADD (dec)	ADD (hex)	REGISTER NAME	BIT(S)	TYPE	DEFAULT (hex)	FUNCTION	DESCRIPTION
15	0x0F	GPO_REG4 and GPIO3 Configurations	7	RW	0x00	GPO_REG4 Output Value	Local GPO_REG4 output value This value is output on the GPO pin when the GPO function is enabled. (The local GPO direction is Output, and remote GPO control is disabled)
			6:5			Reserved	
			4	RW		GPO_REG4 Enable	GPO_REG4 function enable 1: Enable GPO operation 0: Enable normal operation
			3	RW		GPIO3 Output Value	Local GPIO output value This value is output on the GPIO pin when the GPIO function is enabled, the local GPIO direction is Output, and remote GPIO control is disabled.
			2	RW		GPIO3 Remote Enable	Remote GPIO control 1: Enable GPIO control from remote Deserializer. The GPIO pin will be an output, and the value is received from the remote Deserializer. 0: Disable GPIO control from remote Deserializer.
			1	RW		GPIO3 Direction	Local GPIO Direction 1: Input 0: Output
			0	RW		GPIO3 Enable	GPIO function enable 1: Enable GPIO operation 0: Enable normal operation
16	0x10	GPO_REG6 and GPO_REG5 Configurations	7	RW	0x00	GPO_REG6 Output Value	Local GPO_REG6 output value This value is output on the GPO pin when the GPO function is enabled. (The local GPO direction is Output, and remote GPO control is disabled)
			6:5			Reserved	
			4	RW		GPO_REG6 Enable	GPO_REG6 function enable 1: Enable GPO operation 0: Enable normal operation
			3	RW		GPO_REG5 Output Value	Local GPO_REG5 output value This value is output on the GPO pin when the GPO function is enabled, the local GPO direction is Output, and remote GPO control is disabled.
			2:1			Reserved	
			0	RW		GPO_REG5 Enable	GPO_REG5 function enable 1: Enable GPO operation 0: Enable normal operation

Table 7. Serial Control Bus Registers (continued)

ADD (dec)	ADD (hex)	REGISTER NAME	BIT(S)	TYPE	DEFAULT (hex)	FUNCTION	DESCRIPTION
17	0x11	GPO_REG7 Configurations	7:4	RW	0x00	Reserved	Reserved
			3	RW		GPO_REG7 Output Value	Local GPO_REG7 output value This value is output on the GPO pin when the GPO function is enabled, the local GPO direction is Output, and remote GPO control is disabled.
			2:1				Reserved
			0	RW		GPO_REG7 Enable	GPO_REG7 function enable 1: Enable GPO operation 0: Enable normal operation
18	0x12	Data Path Control	7:6		0x00		Reserved
			5	RW		DE Polarity	The bit indicates the polarity of the DE (Data Enable) signal. 1: DE is inverted (active low, idle high) 0: DE is positive (active high, idle low)
			4	RW		I2S Repeater Regen	I2S Repeater Regeneration 1: Repeater regenerate I2S from I2S pins 0: Repeater pass through I2S from video pins
			3				Reserved
			2	RW		18-bit Video Select	18-bit video select 1: Select 18-bit video mode Note: use of GPIO(s) on unused inputs must be enabled by register. 0: Select 24-bit video mode
			1	RW		I2S Transport Select	I2S Transport Mode Slect 1: Enable I2S Data Forward Channel Frame Transport 0: Enable I2S Data Island Transport
			0				Reserved
19	0x13	Mode Status	7:5		0x10		Reserved
			4	R		MODE_SEL	MODE_SEL Status 1: MODE_SEL decode circuit is completed 0: MODE_SEL decode circuit is not completed
			3	R		Alternate Frequency Mode	Alternate Frequency Mode Status Indicates either Low Frequency mode or Intermediate Frequency mode, depending on FSEL status. See Frequency Mode Optimizations .
			2	R		Repeater Mode	Repeater Mode Status 1: Repeater mode <i>ON</i> 0: Repeater Mode <i>OFF</i>
			1	R			Reserved
			0	R		18-Bit Mode	18-bit Mode Strap Status. The initial strap value can be overridden by register 0x12[2]. 1: 18-bit RGB mode 0: 24-bit RGB mode

Table 7. Serial Control Bus Registers (continued)

ADD (dec)	ADD (hex)	REGISTER NAME	BIT(S)	TYPE	DEFAULT (hex)	FUNCTION	DESCRIPTION
20	0x14	Oscillator Clock Source and BIST Status	7:3		0x00		Reserved
			2:1	RW		OSC Clock Source	OSC Clock Source (When LFMODE = 1, Oscillator = 12.5MHz ONLY) 00: External Pixel Clock 01: 33 MHz Oscillator 10: Reserved 11: 25 MHz Oscillator
			0	R		BIST Enable Status	BIST status 1: Enabled 0: Disabled
22	0x16	BCC Watchdog Control	7:1	RW	0xFE	Timer Value	The watchdog timer allows termination of a control channel transaction if it fails to complete within a programmed amount of time. This field sets the Bidirectional Control Channel Watchdog Timeout value in units of 2 ms. This field should not be set to 0
			0	RW		Timer Control	Disable Bidirectional Control Channel Watchdog Timer 1: Disables BCC Watchdog Timer operation 0: Enables BCC Watchdog Timer operation
23	0x17	I2C Control	7	RW	0x5E	I2C Pass All	I2C Control 1: Enable Forward Control Channel pass-through of all I2C accesses to I2C Slave IDs that do not match the Serializer I2C Slave ID. 0: Enable Forward Control Channel pass-through only of I2C accesses to I2C Slave IDs matching either the remote Deserializer Slave ID or the remote Slave ID.
			6				Reserved
			5:4	RW		SDA Hold Time	Internal SDA Hold Time Configures the amount of internal hold time provided for the SDA input relative to the SCL input. Units are 40 ns
			3:0	RW		I2C Filter Depth	Configures the maximum width of glitch pulses on the SCL and SDA inputs that will be rejected. Units are 5 ns
24	0x18	SCL High Time	7:0	RW	0xA1	SCL HIGH Time	I2C Master SCL High Time This field configures the high pulse width of the SCL output when the Serializer is the Master on the local I2C bus. Units are 40 ns for the nominal oscillator clock frequency. The default value is set to provide a minimum 5us SCL high time with the internal oscillator clock running at 32.5MHz rather than the nominal 25MHz.

Table 7. Serial Control Bus Registers (continued)

ADD (dec)	ADD (hex)	REGISTER NAME	BIT(S)	TYPE	DEFAULT (hex)	FUNCTION	DESCRIPTION
25	0x19	SCL Low Time	7:0	RW	0xA5	SCL LOW Time	I2C SCL Low Time This field configures the low pulse width of the SCL output when the Serializer is the Master on the local I2C bus. This value is also used as the SDA setup time by the I2C Slave for providing data prior to releasing SCL during accesses over the Bidirectional Control Channel. Units are 40 ns for the nominal oscillator clock frequency. The default value is set to provide a minimum 5us SCL low time with the internal oscillator clock running at 32.5MHz rather than the nominal 25MHz.
27	0x1B	BIST BC Error	7:0	R	0x00	BIST Back Channel CRC Error Counter	BIST Mode Back Channel CRC Error Counter This error counter is active only in the BIST mode. It clears itself at the start of the BIST run.
53	0x35	FSEL Override	7	RW	0	FSEL Register Override Control	FSEL Override. FSEL value is set by pin or through register. 0: FSEL set by pin 15 at power-up 1: FSEL is set by register 0x35[6]
			6	RW	0	FSEL Override Value	This value will be used for FSEL when FSEL Register Override is set (0x35[7]). See Frequency Mode Optimizations .
			5:0	RW	0	RESERVED	Reserved.
100	0x64	Pattern Generator Control	7:4	RW	0x10	Pattern Generator Select	Fixed Pattern Select This field selects the pattern to output when in Fixed Pattern Mode. Scaled patterns are evenly distributed across the horizontal or vertical active regions. This field is ignored when Auto-Scrolling Mode is enabled. The following table shows the color selections in non-inverted followed by inverted color mode 0000: Reserved 0001: White/Black 0010: Black/White 0011: Red/Cyan 0100: Green/Magenta 0101: Blue/Yellow 0110: Horizontally Scaled Black to White/White to Black 0111: Horizontally Scaled Black to Red/Cyan to White 1000: Horizontally Scaled Black to Green/Magenta to White 1001: Horizontally Scaled Black to Blue/Yellow to White 1010: Vertically Scaled Black to White/White to Black 1011: Vertically Scaled Black to Red/Cyan to White 1100: Vertically Scaled Black to Green/Magenta to White 1101: Vertically Scaled Black to Blue/Yellow to White 1110: Custom color (or its inversion) configured in PGRS, PGGs, PGBs registers 1111: Reserved
			3:1				Reserved
			0	RW		Pattern Generator Enable	Pattern Generator Enable 1: Enable Pattern Generator 0: Disable Pattern Generator

Table 7. Serial Control Bus Registers (continued)

ADD (dec)	ADD (hex)	REGISTER NAME	BIT(S)	TYPE	DEFAULT (hex)	FUNCTION	DESCRIPTION
101	0x65	Pattern Generator Configuration	7:5		0x00		Reserved
			4	RW		Pattern Generator 18 Bits	18-bit Mode Select 1: Enable 18-bit color pattern generation. Scaled patterns will have 64 levels of brightness and the R, G, and B outputs use the six most significant color bits. 0: Enable 24-bit pattern generation. Scaled patterns use 256 levels of brightness.
			3	RW		Pattern Generator External Clock	Select External Clock Source 1: Selects the external pixel clock when using internal timing. 0: Selects the internal divided clock when using internal timing This bit has no effect in external timing mode (PATGEN_TSEL = 0).
			2	RW		Pattern Generator Timing Select	Timing Select Control 1: The Pattern Generator creates its own video timing as configured in the Pattern Generator Total Frame Size, Active Frame Size, Horizontal Sync Width, Vertical Sync Width, Horizontal Back Porch, Vertical Back Porch, and Sync Configuration registers. 0: the Pattern Generator uses external video timing from the pixel clock, Data Enable, Horizontal Sync, and Vertical Sync signals.
			1	RW		Pattern Generator Color Invert	Enable Inverted Color Patterns 1: Invert the color output. 0: Do not invert the color output.
			0	RW		Pattern Generator Auto-Scroll Enable	Auto-Scroll Enable: 1: The Pattern Generator will automatically move to the next enabled pattern after the number of frames specified in the Pattern Generator Frame Time (PGFT) register. 0: The Pattern Generator retains the current pattern.
102	0x66	Pattern Generator Indirect Address	7:0	RW	0x00	Indirect Address	This 8-bit field sets the indirect address for accesses to indirectly-mapped registers. It should be written prior to reading or writing the Pattern Generator Indirect Data register. See AN-2198 (SNLA132).
103	0x67	Pattern Generator Indirect Data	7:0	RW	0x00	Indirect Data	When writing to indirect registers, this register contains the data to be written. When reading from indirect registers, this register contains the read back value. See AN-2198 (SNLA132).
198	0xC6	ICR	7:6				Reserved
			5	RW		IS_RX_INT	Interrupt on Receiver interrupt Enables interrupt on indication from the Receiver. Allows propagation of interrupts from downstream devices
			4:1				Reserved
			0	RW		INT Enable	Global Interrupt Enable Enables interrupt on the interrupt signal to the controller.

Table 7. Serial Control Bus Registers (continued)

ADD (dec)	ADD (hex)	REGISTER NAME	BIT(S)	TYPE	DEFAULT (hex)	FUNCTION	DESCRIPTION
199	0xC7	ISR	7:6				<i>Reserved</i>
			5	R		IS RX INT	Interrupt on Receiver interrupt Receiver has indicated an interrupt request from down-stream device
			4:1				<i>Reserved</i>
			0	R		INT	Global Interrupt Set if any enabled interrupt is indicated

8 Application and Implementation

NOTE

Information in the following applications sections is not part of the TI component specification, and TI does not warrant its accuracy or completeness. TI's customers are responsible for determining suitability of components for their purposes. Customers should validate and test their design implementation to confirm system functionality.

8.1 Application Information

The DS90UB921-Q1, in conjunction with the DS90UB948-Q1, is intended for interface between a host (graphics processor) and a Display. It supports a 24-bit color depth (RGB888) and extended high definition (1920x720p) digital video format. It can receive a three 8-bit RGB stream with a pixel rate up to 96 MHz together with three control bits (VS, HS and DE) and three I2S-bus audio stream with an audio sampling rate up to 192 kHz.

8.2 AVMUTE Operation

When using DS90UB921-Q1, it is possible to send video data during the blanking period (DE = L). If a specific pattern is sent during the blanking period, the paired Deserializer will enter AVMUTE mode. The pattern that the Deserializer is looking for is 24'h666666. If the last pixel of the frame is 24'h666666, and the video transmission extends into the DE = L, period, then AVMUTE mode will be enabled.

Setting 0x04[1] = "1" on the DS90UB921-Q1 will prevent video from being sent during the blanking interval. This will ensure AVMUTE mode is not entered during normal operation.

8.3 Typical Application

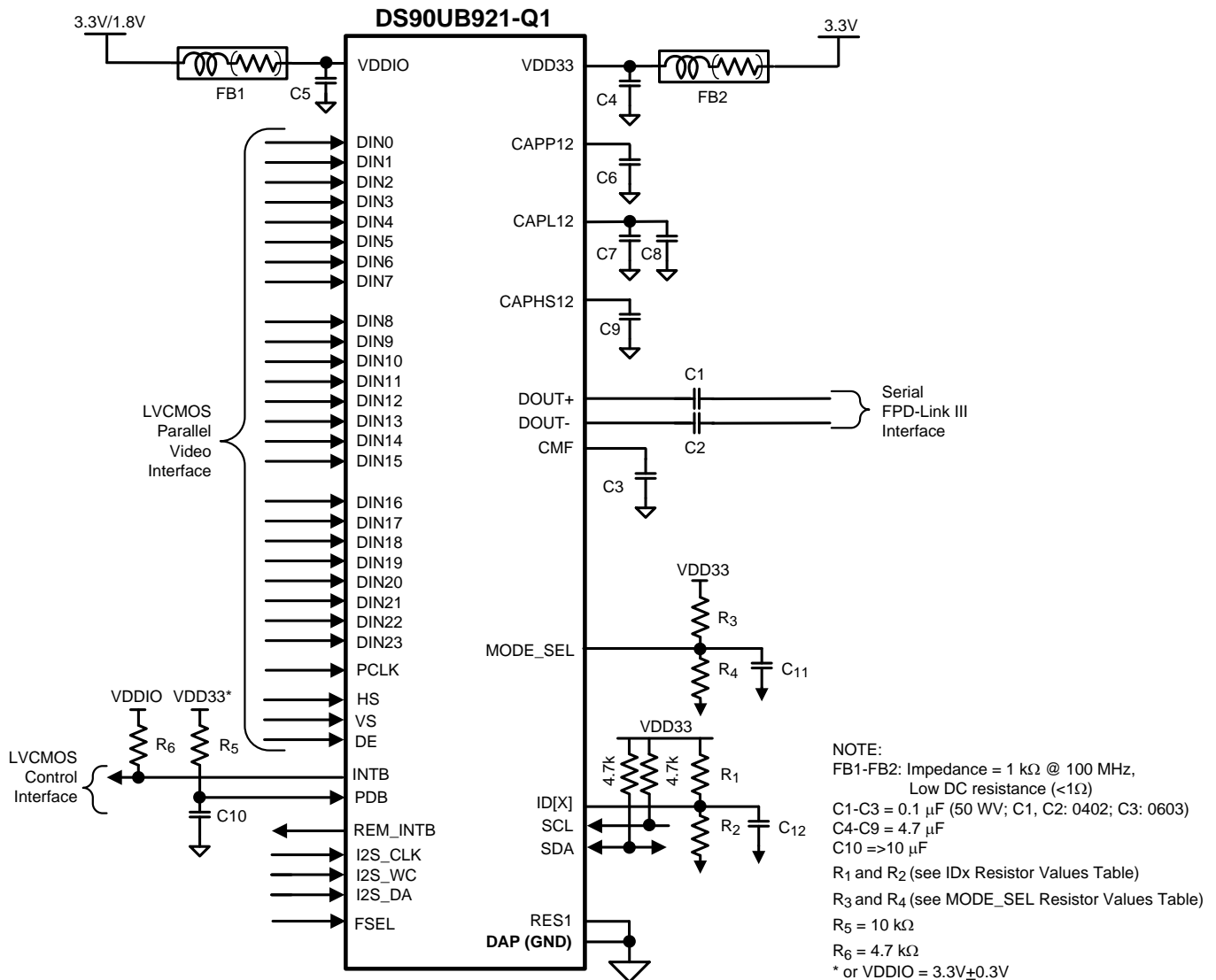

Figure 26. Typical STP Connection Diagram

Typical Application (continued)

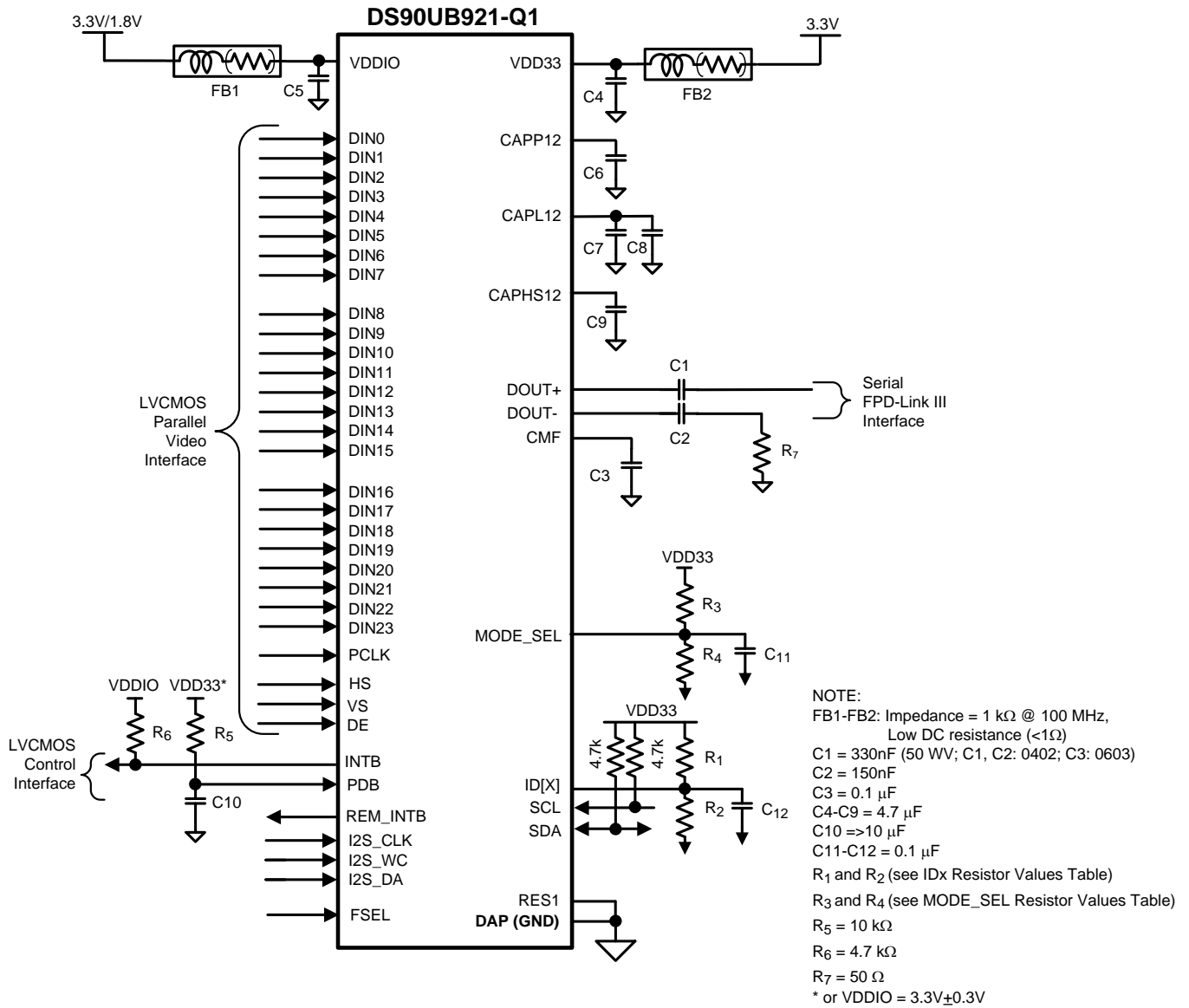

Figure 27. Typical Coax Connection Diagram

Typical Application (continued)

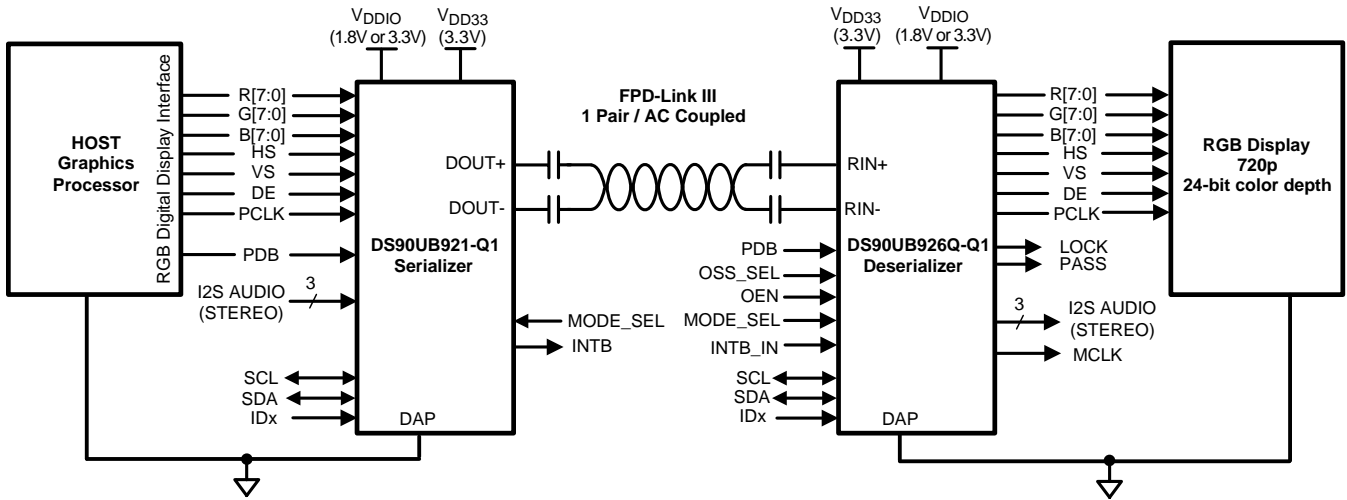

Figure 28. Typical STP System Diagram

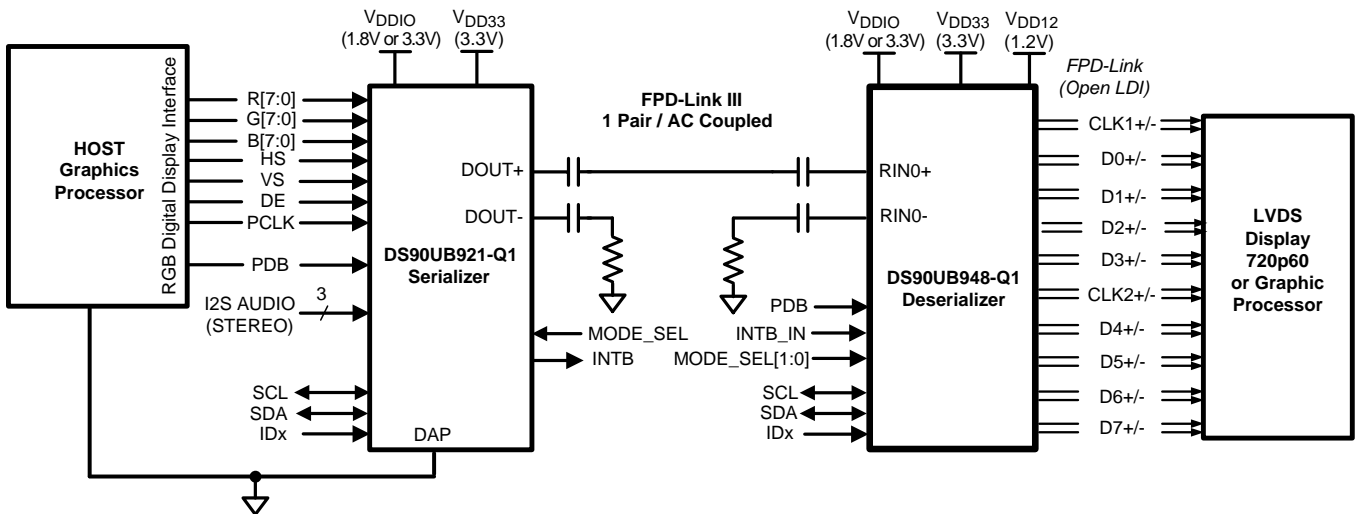

Figure 29. Typical Coax Applications Diagram

8.3.1 Design Requirements

For the typical design application, use the following as input parameters.

Table 8. Design Parameters

DESIGN PARAMETER	EXAMPLE VALUE
VDDIO	1.8 V or 3.3 V
VDD33	3.3 V
AC Coupling Capacitor for DOUT±	100 nF on DOUT+ and 100nF on DOUT- for STP 330nF on DOUT+ and 150nF on DOUT- for Coax
PCLK Frequency	74.25 MHz

8.3.2 Detailed Design Procedure

Figure 26 shows a typical application of the DS90UB921-Q1 serializer for an 96 MHz 24-bit Color Display Application. The CML outputs must have an external 0.1 μF AC coupling capacitor on the high speed serial lines for STP applications and 0.33 μF / 0.15 μF AC coupling capacitors for coax applications. The same AC coupling capacitor values should be used on the paired deserializer board. The serializer has an internal termination. Bypass capacitors are placed near the power supply pins. At a minimum, six (6) 4.7 μF capacitors and two (2) additional 1 μF capacitors should be used for local device bypassing. Ferrite beads are placed on the two (2) VDDs (VDD33 and VDDIO) for effective noise suppression. The interface to the graphics source is with 3.3V LVCMOS levels, thus the VDDIO pin is connected to the 3.3 V rail.

8.3.3 Application Curves

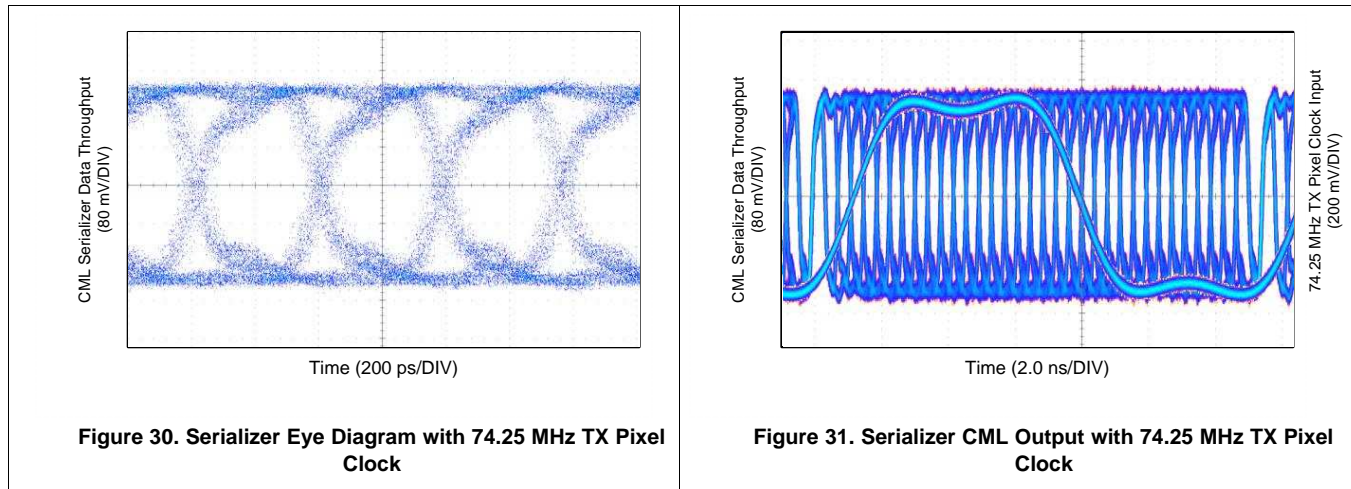

9 Power Supply Recommendations

9.1 Power Up Requirements and PDB Pin

When VDDIO and VDD33 are powered separately, the VDDIO supply (1.8V or 3.3V) should ramp 100us before the other supply, VDD33. If VDDIO is tied with VDD33, both supplies may ramp at the same time. The VDDs (VDD33 and VDDIO) supply ramp should be faster than 1.5 ms with a monotonic rise. If the PDB pin is not controlled by a microcontroller, a large capacitor on the pin is needed to ensure PDB arrives after all the VDDs have settled to the recommended operating voltage. When PDB pin is pulled to VDDIO = 3.0V to 3.6V or VDD33, it is recommended to use a 10 kΩ pull-up and a >10 uF cap to GND to delay the PDB input signal.

A minimum low pulse of 2ms is required when toggling the PDB pin to perform a hard reset.

All inputs must not be driven until VDD33 and VDDIO has reached its steady state value.

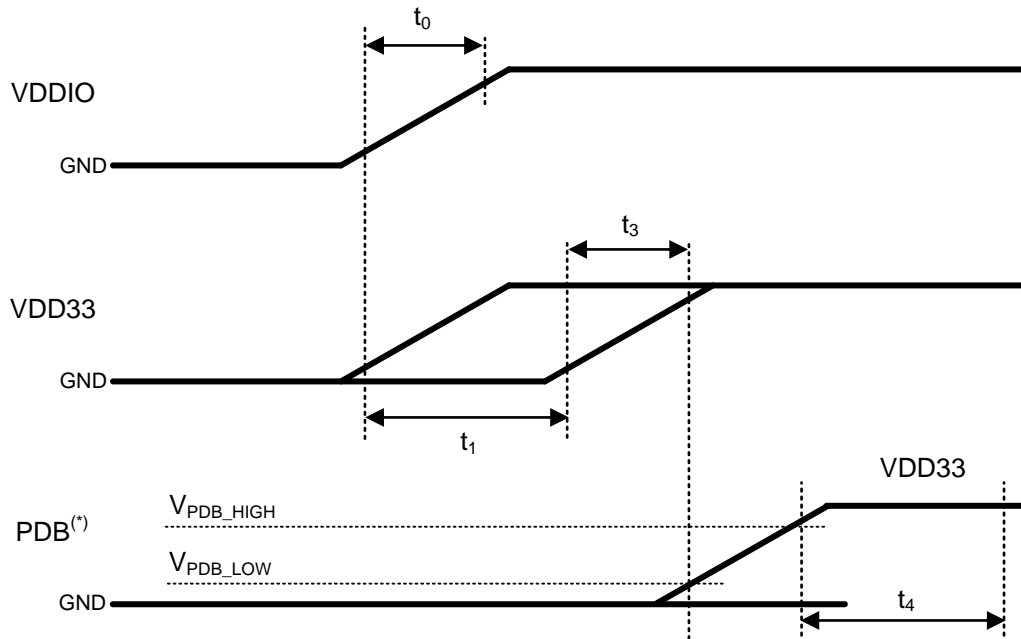

(*) It is recommended to assert PDB (active High) with a microcontroller rather than an RC filter network to help ensure proper sequencing of PDB pin after settling of power supplies.

Figure 32. Timing Diagram of DS90UB921-Q1

Table 9. Power-Up Sequencing Constraints

Symbol	Description	Test Conditions	Min	Typ	Max	Units
VDDIO	VDDIO voltage range		3.0		3.6	V
			1.71		1.89	V
VDD33	VDD33 voltage range		3.0		3.6	V
V_{PDB_LOW}	PDB LOW threshold Note: V_{PDB} should not exceed limit for respective I/O voltage before 90% voltage of VDD12	VDDIO = 3.3V ± 10%	0.8			V
V_{PDB_HIGH}	PDB HIGH threshold	VDDIO = 3.3V ± 10%			2.0	V
t_0	VDDIO rise time	These time constants are specified for rise time of power supply voltage ramp (10% - 90%)	0.05		<1.5	ms
t_3	VDD33 rise time	These time constants are specified for rise time of power supply voltage ramp (10% - 90%)	0.05		<1.5	ms

Power Up Requirements and PDB Pin (continued)
Table 9. Power-Up Sequencing Constraints (continued)

Symbol	Description	Test Conditions	Min	Typ	Max	Units
t_1	VDD33 delay time	V_{IL} of rising edge (VDDIO) to V_{IL} of rising edge (VDD33) The power supplies may be ramped simultaneously. If sequenced, VDDIO should be first..	>0			ms
t_4	Startup time	The part is powered up after the startup time has elapsed from the moment PDB goes HIGH. Local I2C is available to read/write 921 registers after this time.			<1	ms

This device is designed to operate from an input core voltage supply of 3.3V. Some devices provide separate power and ground terminals for different portions of the circuit. This is done to isolate switching noise effects between different sections of the circuit. Separate planes on the PCB are typically not required. Terminal description tables typically provide guidance on which circuit blocks are connected to which power terminal pairs. In some cases, an external filter may be used to provide clean power to sensitive circuits such as PLLs.

9.2 CML Interconnect Guidelines

See AN-1108 ([SNLA008](#)) and AN-905 ([SNLA035](#)) for full details.

- Use 100Ω coupled differential pairs
- Use the S/2S/3S rule in spacings
 - – S = space between the pair
 - – 2S = space between pairs
 - – 3S = space to LVCMOS signal
- Minimize the number of Vias
- Use differential connectors when operating above 500 Mbps line speed
- Maintain balance of the traces
- Minimize skew within the pair

Additional general guidance can be found in the LVDS Owner's Manual - available in PDF format from the Texas Instruments web site at: www.ti.com/lvds.

10 Layout

10.1 Layout Guidelines

Circuit board layout and stack-up for the FPD-Link III devices should be designed to provide low-noise power feed to the device. Good layout practice will also separate high frequency or high-level inputs and outputs to minimize unwanted stray noise pickup, feedback and interference. Power system performance may be greatly improved by using thin dielectrics (2 to 4 mils) for power / ground sandwiches. This arrangement provides plane capacitance for the PCB power system with low-inductance parasitics, which has proven especially effective at high frequencies, and makes the value and placement of external bypass capacitors less critical. External bypass capacitors should include both RF ceramic and tantalum electrolytic types. RF capacitors may use values in the range of 0.01 uF to 0.1 uF. Tantalum capacitors may be in the 2.2 uF to 10 uF range. Voltage rating of the tantalum capacitors should be at least 5X the power supply voltage being used.

Surface mount capacitors are recommended due to their smaller parasitics. When using multiple capacitors per supply pin, locate the smaller value closer to the pin. A large bulk capacitor is recommended at the point of power entry. This is typically in the 50uF to 100uF range and will smooth low frequency switching noise. It is recommended to connect power and ground pins directly to the power and ground planes with bypass capacitors connected to the plane with via on both ends of the capacitor. Connecting power or ground pins to an external bypass capacitor will increase the inductance of the path.

A small body size X7R chip capacitor, such as 0603 or 0402, is recommended for external bypass. Its small body size reduces the parasitic inductance of the capacitor. The user must pay attention to the resonance frequency of these external bypass capacitors, usually in the range of 20-30 MHz. To provide effective bypassing, multiple capacitors are often used to achieve low impedance between the supply rails over the frequency of interest. At high frequency, it is also a common practice to use two vias from power and ground pins to the planes, reducing the impedance at high frequency.

Some devices provide separate power and ground pins for different portions of the circuit. This is done to isolate switching noise effects between different sections of the circuit. Separate planes on the PCB are typically not required. Pin Description tables typically provide guidance on which circuit blocks are connected to which power pin pairs. In some cases, an external filter may be used to provide clean power to sensitive circuits such as PLLs.

Use at least a four layer board with a power and ground plane. Locate LVCMOS signals away from the CML lines to prevent coupling from the LVCMOS lines to the CML lines. Closely-coupled differential lines of 100 Ohms are typically recommended for CML interconnect. The closely coupled lines help to ensure that coupled noise will appear as common-mode and thus is rejected by the receivers. The tightly coupled lines will also radiate less.

Information on the WQFN style package is provided in TI Application Note: AN-1187 ([SNOA401](#)).

10.2 Layout Example

Stencil parameters such as aperture area ratio and the fabrication process have a significant impact on paste deposition. Inspection of the stencil prior to placement of the WQFN package is highly recommended to improve board assembly yields. If the via and aperture openings are not carefully monitored, the solder may flow unevenly through the DAP. Stencil parameters for aperture opening and via locations are shown below:

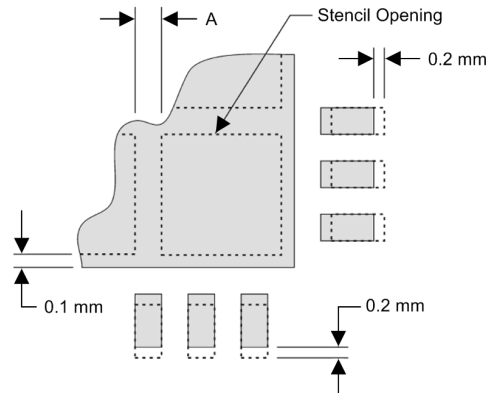

Figure 33. No Pullback WQFN, Single Row Reference Diagram

Table 10. No Pullback WQFN Stencil Aperture Summary

DEVICE	PIN COUNT	MKT Dwg	PCB I/O Pad Size (mm)	PCB PITCH (mm)	PCB DAP SIZE (mm)	STENCIL I/O APERTURE (mm)	STENCIL DAP Aperture (mm)	NUMBER of DAP APERTURE OPENINGS	GAP BETWEEN DAP APERTURE (Dim A mm)
DS90UB921-Q1	48	SQA48A	0.25 x 0.6	0.5	5.1 x 5.1	0.25 x 0.7	1.1 x 1.1	16	0.2

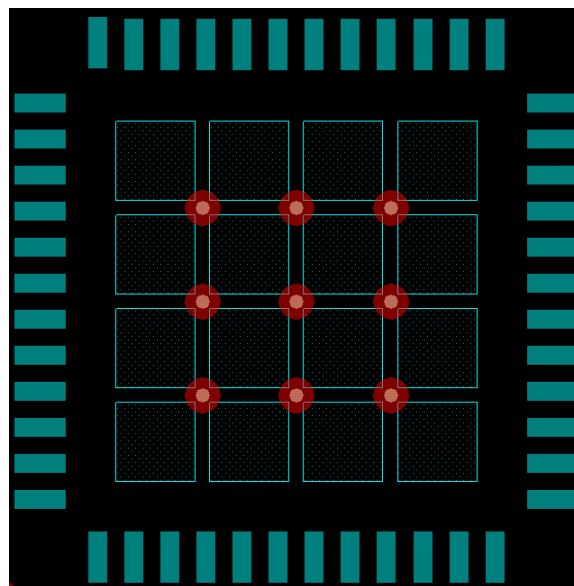

Figure 34. 48-Pin WQFN Stencil Example of Via and Opening Placement

Figure 35 and Figure 36 PCB layout examples are derived from the layout design of the DS90UB921-Q1EVM Evaluation Board. The graphic and layout description are used to determine proper routing when designing the Serializer board. Figure 35 shows the high speed FPD-Link III traces routed differentially to the connector. The traces are buried in an internal layer with a GND layer and power layer on each adjacent layer. Burying the traces helps reduce emissions, and it is important not to route other high speed signals near these critical signal traces. 100Ω differential characteristic impedance and 50Ω single-ended characteristic impedance traces are maintained as much as possible for both STP and coax applications. For layout of a coax board, 100Ω coupled traces should be used with the DOUT- termination near to the connector.

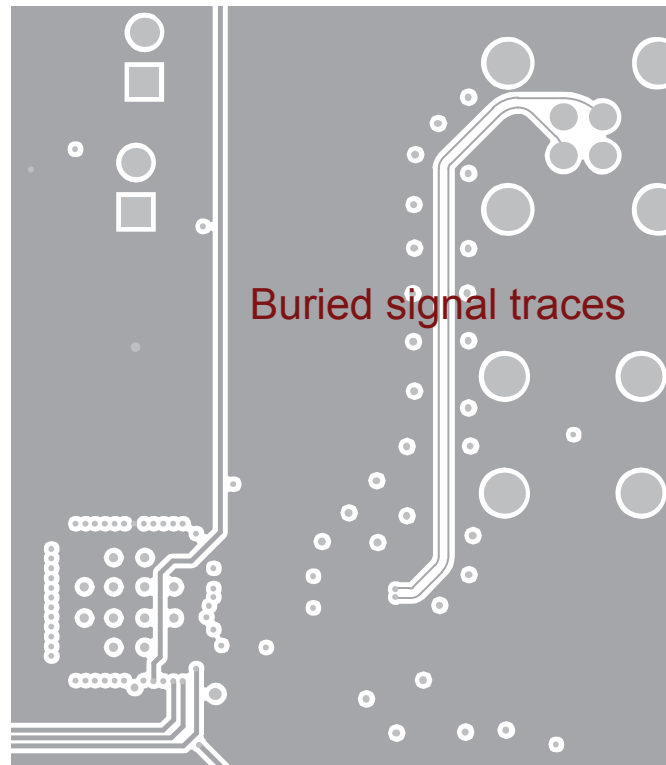

Figure 35. DS90UB921-Q1 Serializer Example Layout, Inner Layer

Figure 36 shows the high speed FPD-Link III traces close to the DOUT± pins. In this case, the AC coupling capacitors are on the opposite side of the board, so there is an additional via that would not be needed if the components were all on the same side. This via, the AC coupling capacitors, the common-mode choke, and the second via (going to the buried traces to the connector) are all placed closely together so that the impedance discontinuity appears as tightly grouped as possible.



Figure 36. DS90UB921-Q1 Serializer Example Layout, Bottom Layer

11 Device and Documentation Support

11.1 Documentation Support

11.1.1 Related Documentation

- AN-2198 Exploring the Internal Test Pattern Generation [SNLA132](#)
- AN-1108 Channel-Link PCB and Interconnect Design-In Guidelines [SNLA008](#)
- SCAN18245T Non-Inverting Transceiver with TRI-STATE Outputs [SNLA035](#)
- TI Interface Website www.ti.com/lvds
- AN-1187 Leadless Leadframe Package (LLP) [SNOA401](#)
- Semiconductor and IC Package Thermal Metrics [SPRA953](#)

11.2 Community Resources

The following links connect to TI community resources. Linked contents are provided "AS IS" by the respective contributors. They do not constitute TI specifications and do not necessarily reflect TI's views; see TI's [Terms of Use](#).

TI E2E™ Online Community *TI's Engineer-to-Engineer (E2E) Community*. Created to foster collaboration among engineers. At e2e.ti.com, you can ask questions, share knowledge, explore ideas and help solve problems with fellow engineers.

Design Support *TI's Design Support* Quickly find helpful E2E forums along with design support tools and contact information for technical support.

11.3 Trademarks

E2E is a trademark of Texas Instruments.

11.4 Electrostatic Discharge Caution



These devices have limited built-in ESD protection. The leads should be shorted together or the device placed in conductive foam during storage or handling to prevent electrostatic damage to the MOS gates.

11.5 Glossary

[SLYZ022](#) — *TI Glossary*.

This glossary lists and explains terms, acronyms, and definitions.

12 Mechanical, Packaging, and Orderable Information

The following pages include mechanical, packaging, and orderable information. This information is the most current data available for the designated devices. This data is subject to change without notice and revision of this document. For browser-based versions of this data sheet, refer to the left-hand navigation.

PACKAGING INFORMATION

Orderable Device	Status (1)	Package Type	Package Drawing	Pins	Package Qty	Eco Plan (2)	Lead/Ball Finish (6)	MSL Peak Temp (3)	Op Temp (°C)	Device Marking (4/5)	Samples
DS90UB921TRHSRQ1	ACTIVE	WQFN	RHS	48	1000	Green (RoHS & no Sb/Br)	CU SN	Level-3-260C-168 HR	-40 to 105	UB921Q	Samples
DS90UB921TRHSTQ1	ACTIVE	WQFN	RHS	48	250	Green (RoHS & no Sb/Br)	CU SN	Level-3-260C-168 HR	-40 to 105	UB921Q	Samples

(1) The marketing status values are defined as follows:

ACTIVE: Product device recommended for new designs.

LIFEBUY: TI has announced that the device will be discontinued, and a lifetime-buy period is in effect.

NRND: Not recommended for new designs. Device is in production to support existing customers, but TI does not recommend using this part in a new design.

PREVIEW: Device has been announced but is not in production. Samples may or may not be available.

OBsolete: TI has discontinued the production of the device.

(2) Eco Plan - The planned eco-friendly classification: Pb-Free (RoHS), Pb-Free (RoHS Exempt), or Green (RoHS & no Sb/Br) - please check <http://www.ti.com/productcontent> for the latest availability information and additional product content details.

TBD: The Pb-Free/Green conversion plan has not been defined.

Pb-Free (RoHS): TI's terms "Lead-Free" or "Pb-Free" mean semiconductor products that are compatible with the current RoHS requirements for all 6 substances, including the requirement that lead not exceed 0.1% by weight in homogeneous materials. Where designed to be soldered at high temperatures, TI Pb-Free products are suitable for use in specified lead-free processes.

Pb-Free (RoHS Exempt): This component has a RoHS exemption for either 1) lead-based flip-chip solder bumps used between the die and package, or 2) lead-based die adhesive used between the die and leadframe. The component is otherwise considered Pb-Free (RoHS compatible) as defined above.

Green (RoHS & no Sb/Br): TI defines "Green" to mean Pb-Free (RoHS compatible), and free of Bromine (Br) and Antimony (Sb) based flame retardants (Br or Sb do not exceed 0.1% by weight in homogeneous material)

(3) MSL, Peak Temp. - The Moisture Sensitivity Level rating according to the JEDEC industry standard classifications, and peak solder temperature.

(4) There may be additional marking, which relates to the logo, the lot trace code information, or the environmental category on the device.

(5) Multiple Device Markings will be inside parentheses. Only one Device Marking contained in parentheses and separated by a "~" will appear on a device. If a line is indented then it is a continuation of the previous line and the two combined represent the entire Device Marking for that device.

(6) Lead/Ball Finish - Orderable Devices may have multiple material finish options. Finish options are separated by a vertical ruled line. Lead/Ball Finish values may wrap to two lines if the finish value exceeds the maximum column width.

Important Information and Disclaimer: The information provided on this page represents TI's knowledge and belief as of the date that it is provided. TI bases its knowledge and belief on information provided by third parties, and makes no representation or warranty as to the accuracy of such information. Efforts are underway to better integrate information from third parties. TI has taken and continues to take reasonable steps to provide representative and accurate information but may not have conducted destructive testing or chemical analysis on incoming materials and chemicals. TI and TI suppliers consider certain information to be proprietary, and thus CAS numbers and other limited information may not be available for release.

In no event shall TI's liability arising out of such information exceed the total purchase price of the TI part(s) at issue in this document sold by TI to Customer on an annual basis.

TAPE AND REEL INFORMATION



QUADRANT ASSIGNMENTS FOR PIN 1 ORIENTATION IN TAPE



*All dimensions are nominal

Device	Package Type	Package Drawing	Pins	SPQ	Reel Diameter (mm)	Reel Width W1 (mm)	A0 (mm)	B0 (mm)	K0 (mm)	P1 (mm)	W (mm)	Pin1 Quadrant
DS90UB921TRHSRQ1	WQFN	RHS	48	1000	330.0	16.4	7.3	7.3	1.3	12.0	16.0	Q1
DS90UB921TRHSTQ1	WQFN	RHS	48	250	178.0	16.4	7.3	7.3	1.3	12.0	16.0	Q1

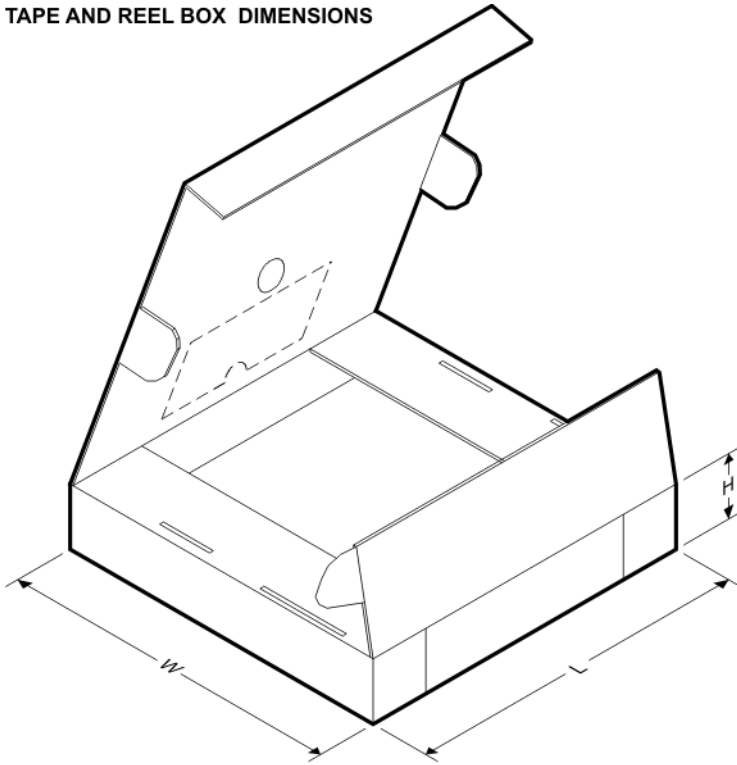
TAPE AND REEL BOX DIMENSIONS

*All dimensions are nominal

Device	Package Type	Package Drawing	Pins	SPQ	Length (mm)	Width (mm)	Height (mm)
DS90UB921TRHSRQ1	WQFN	RHS	48	1000	367.0	367.0	38.0
DS90UB921TRHSTQ1	WQFN	RHS	48	250	210.0	185.0	35.0

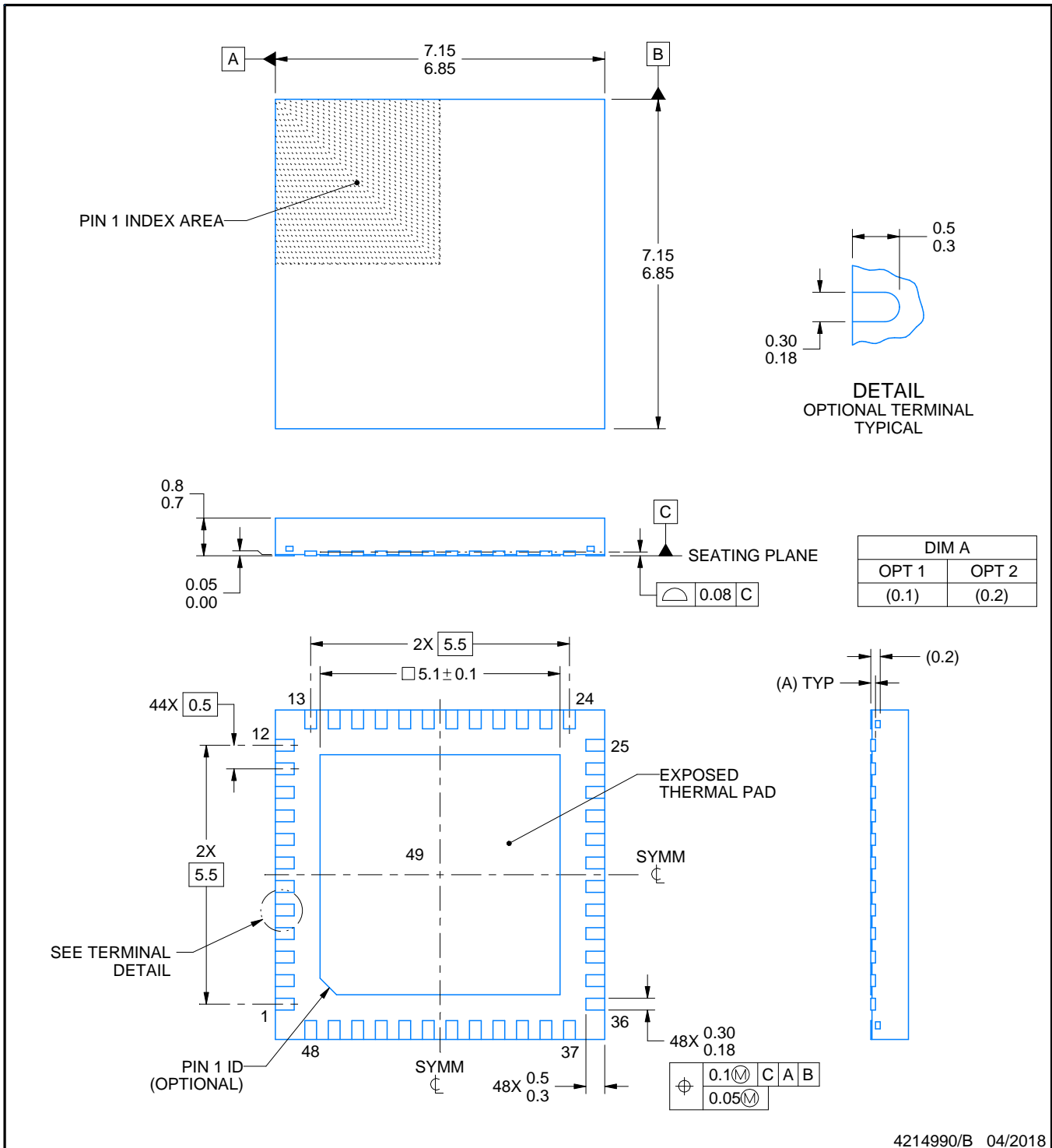
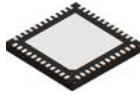

4214990/B 04/2018

NOTES:

1. All linear dimensions are in millimeters. Any dimensions in parenthesis are for reference only. Dimensioning and tolerancing per ASME Y14.5M.
2. This drawing is subject to change without notice.
3. The package thermal pad must be soldered to the printed circuit board for thermal and mechanical performance.

EXAMPLE BOARD LAYOUT

RHS0048A

WQFN - 0.8 mm max height

PLASTIC QUAD FLATPACK - NO LEAD

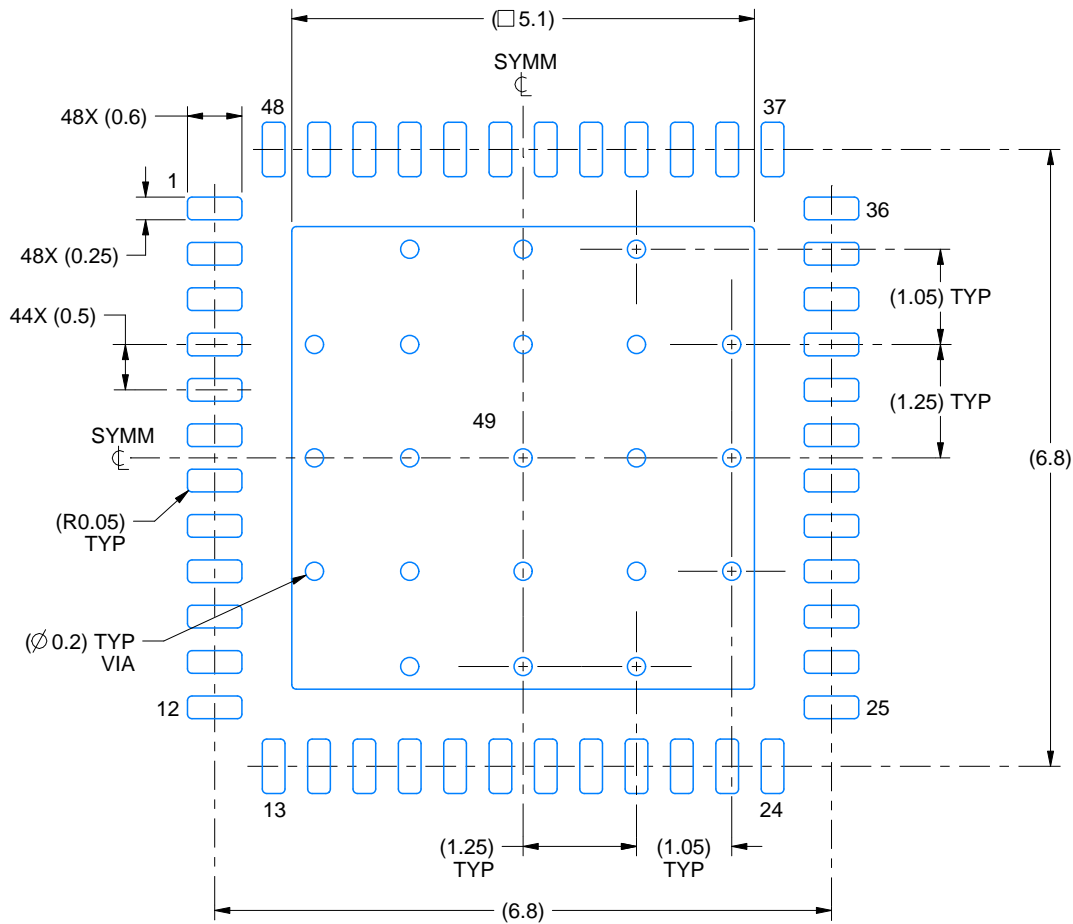

LAND PATTERN EXAMPLE
EXPOSED METAL SHOWN
SCALE:12X

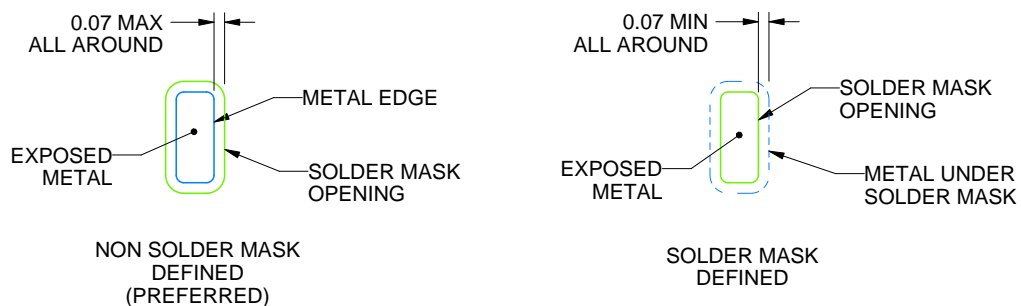

SOLDER MASK DETAILS

4214990/B 04/2018

NOTES: (continued)

4. This package is designed to be soldered to a thermal pad on the board. For more information, see Texas Instruments literature number SLUA271 (www.ti.com/lit/slua271).
5. Vias are optional depending on application, refer to device data sheet. If any vias are implemented, refer to their locations shown on this view. It is recommended that vias under paste be filled, plugged or tented.

EXAMPLE STENCIL DESIGN

RHS0048A

WQFN - 0.8 mm max height

PLASTIC QUAD FLATPACK - NO LEAD

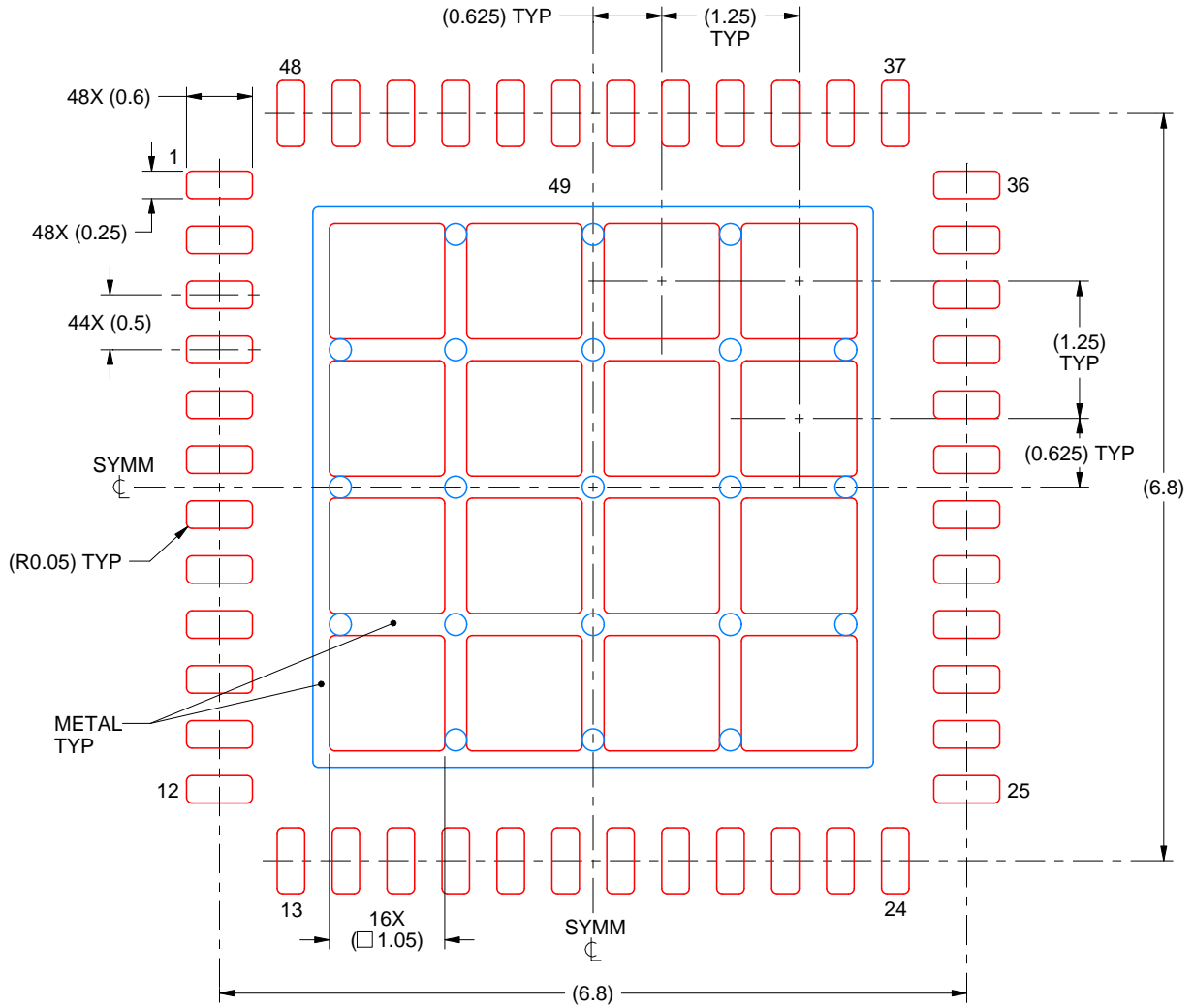

SOLDER PASTE EXAMPLE
 BASED ON 0.125 mm THICK STENCIL

EXPOSED PAD 49
 68% PRINTED SOLDER COVERAGE BY AREA UNDER PACKAGE
 SCALE:15X

4214990/B 04/2018

NOTES: (continued)

6. Laser cutting apertures with trapezoidal walls and rounded corners may offer better paste release. IPC-7525 may have alternate design recommendations.

IMPORTANT NOTICE

Texas Instruments Incorporated (TI) reserves the right to make corrections, enhancements, improvements and other changes to its semiconductor products and services per JESD46, latest issue, and to discontinue any product or service per JESD48, latest issue. Buyers should obtain the latest relevant information before placing orders and should verify that such information is current and complete.

TI's published terms of sale for semiconductor products (<http://www.ti.com/sc/docs/stdterms.htm>) apply to the sale of packaged integrated circuit products that TI has qualified and released to market. Additional terms may apply to the use or sale of other types of TI products and services.

Reproduction of significant portions of TI information in TI data sheets is permissible only if reproduction is without alteration and is accompanied by all associated warranties, conditions, limitations, and notices. TI is not responsible or liable for such reproduced documentation. Information of third parties may be subject to additional restrictions. Resale of TI products or services with statements different from or beyond the parameters stated by TI for that product or service voids all express and any implied warranties for the associated TI product or service and is an unfair and deceptive business practice. TI is not responsible or liable for any such statements.

Buyers and others who are developing systems that incorporate TI products (collectively, "Designers") understand and agree that Designers remain responsible for using their independent analysis, evaluation and judgment in designing their applications and that Designers have full and exclusive responsibility to assure the safety of Designers' applications and compliance of their applications (and of all TI products used in or for Designers' applications) with all applicable regulations, laws and other applicable requirements. Designer represents that, with respect to their applications, Designer has all the necessary expertise to create and implement safeguards that (1) anticipate dangerous consequences of failures, (2) monitor failures and their consequences, and (3) lessen the likelihood of failures that might cause harm and take appropriate actions. Designer agrees that prior to using or distributing any applications that include TI products, Designer will thoroughly test such applications and the functionality of such TI products as used in such applications.

TI's provision of technical, application or other design advice, quality characterization, reliability data or other services or information, including, but not limited to, reference designs and materials relating to evaluation modules, (collectively, "TI Resources") are intended to assist designers who are developing applications that incorporate TI products; by downloading, accessing or using TI Resources in any way, Designer (individually or, if Designer is acting on behalf of a company, Designer's company) agrees to use any particular TI Resource solely for this purpose and subject to the terms of this Notice.

TI's provision of TI Resources does not expand or otherwise alter TI's applicable published warranties or warranty disclaimers for TI products, and no additional obligations or liabilities arise from TI providing such TI Resources. TI reserves the right to make corrections, enhancements, improvements and other changes to its TI Resources. TI has not conducted any testing other than that specifically described in the published documentation for a particular TI Resource.

Designer is authorized to use, copy and modify any individual TI Resource only in connection with the development of applications that include the TI product(s) identified in such TI Resource. NO OTHER LICENSE, EXPRESS OR IMPLIED, BY ESTOPPEL OR OTHERWISE TO ANY OTHER TI INTELLECTUAL PROPERTY RIGHT, AND NO LICENSE TO ANY TECHNOLOGY OR INTELLECTUAL PROPERTY RIGHT OF TI OR ANY THIRD PARTY IS GRANTED HEREIN, including but not limited to any patent right, copyright, mask work right, or other intellectual property right relating to any combination, machine, or process in which TI products or services are used. Information regarding or referencing third-party products or services does not constitute a license to use such products or services, or a warranty or endorsement thereof. Use of TI Resources may require a license from a third party under the patents or other intellectual property of the third party, or a license from TI under the patents or other intellectual property of TI.

TI RESOURCES ARE PROVIDED "AS IS" AND WITH ALL FAULTS. TI DISCLAIMS ALL OTHER WARRANTIES OR REPRESENTATIONS, EXPRESS OR IMPLIED, REGARDING RESOURCES OR USE THEREOF, INCLUDING BUT NOT LIMITED TO ACCURACY OR COMPLETENESS, TITLE, ANY EPIDEMIC FAILURE WARRANTY AND ANY IMPLIED WARRANTIES OF MERCHANTABILITY, FITNESS FOR A PARTICULAR PURPOSE, AND NON-INFRINGEMENT OF ANY THIRD PARTY INTELLECTUAL PROPERTY RIGHTS. TI SHALL NOT BE LIABLE FOR AND SHALL NOT DEFEND OR INDEMNIFY DESIGNER AGAINST ANY CLAIM, INCLUDING BUT NOT LIMITED TO ANY INFRINGEMENT CLAIM THAT RELATES TO OR IS BASED ON ANY COMBINATION OF PRODUCTS EVEN IF DESCRIBED IN TI RESOURCES OR OTHERWISE. IN NO EVENT SHALL TI BE LIABLE FOR ANY ACTUAL, DIRECT, SPECIAL, COLLATERAL, INDIRECT, PUNITIVE, INCIDENTAL, CONSEQUENTIAL OR EXEMPLARY DAMAGES IN CONNECTION WITH OR ARISING OUT OF TI RESOURCES OR USE THEREOF, AND REGARDLESS OF WHETHER TI HAS BEEN ADVISED OF THE POSSIBILITY OF SUCH DAMAGES.

Unless TI has explicitly designated an individual product as meeting the requirements of a particular industry standard (e.g., ISO/TS 16949 and ISO 26262), TI is not responsible for any failure to meet such industry standard requirements.

Where TI specifically promotes products as facilitating functional safety or as compliant with industry functional safety standards, such products are intended to help enable customers to design and create their own applications that meet applicable functional safety standards and requirements. Using products in an application does not by itself establish any safety features in the application. Designers must ensure compliance with safety-related requirements and standards applicable to their applications. Designer may not use any TI products in life-critical medical equipment unless authorized officers of the parties have executed a special contract specifically governing such use. Life-critical medical equipment is medical equipment where failure of such equipment would cause serious bodily injury or death (e.g., life support, pacemakers, defibrillators, heart pumps, neurostimulators, and implantables). Such equipment includes, without limitation, all medical devices identified by the U.S. Food and Drug Administration as Class III devices and equivalent classifications outside the U.S.

TI may expressly designate certain products as completing a particular qualification (e.g., Q100, Military Grade, or Enhanced Product). Designers agree that it has the necessary expertise to select the product with the appropriate qualification designation for their applications and that proper product selection is at Designers' own risk. Designers are solely responsible for compliance with all legal and regulatory requirements in connection with such selection.

Designer will fully indemnify TI and its representatives against any damages, costs, losses, and/or liabilities arising out of Designer's non-compliance with the terms and provisions of this Notice.