

GRF1201

LOG AVERAGE POWER DETECTOR 0.01 to 6 GHz

FEATURES

- Detector slope: 0.08 volts per dB (-20 to +20 dBm)
- Linear logarithmic Power Detector
- Flexible bias voltage
- Minimal external components
- Compact 1.5 x 1.5 mm DFN-6 Package
- Process: InGaP HBT

APPLICATIONS

- High-volume, cost-sensitive logarithmic power detector applications

DESCRIPTION

The GRF1201 is a low-cost, logarithmic, average power detector IC designed for cost-sensitive applications in the 0.01 to 6 GHz frequency range.

The device is operated from a supply voltage range of 2.7 to 5 volts and housed in a 1.5 x 1.5 x 0.5 mm 6-pin plastic DFN package.

Consult with the GRF applications engineering team for technical support.

BLOCK DIAGRAM

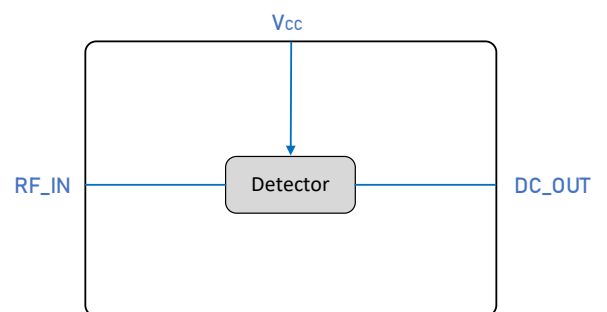

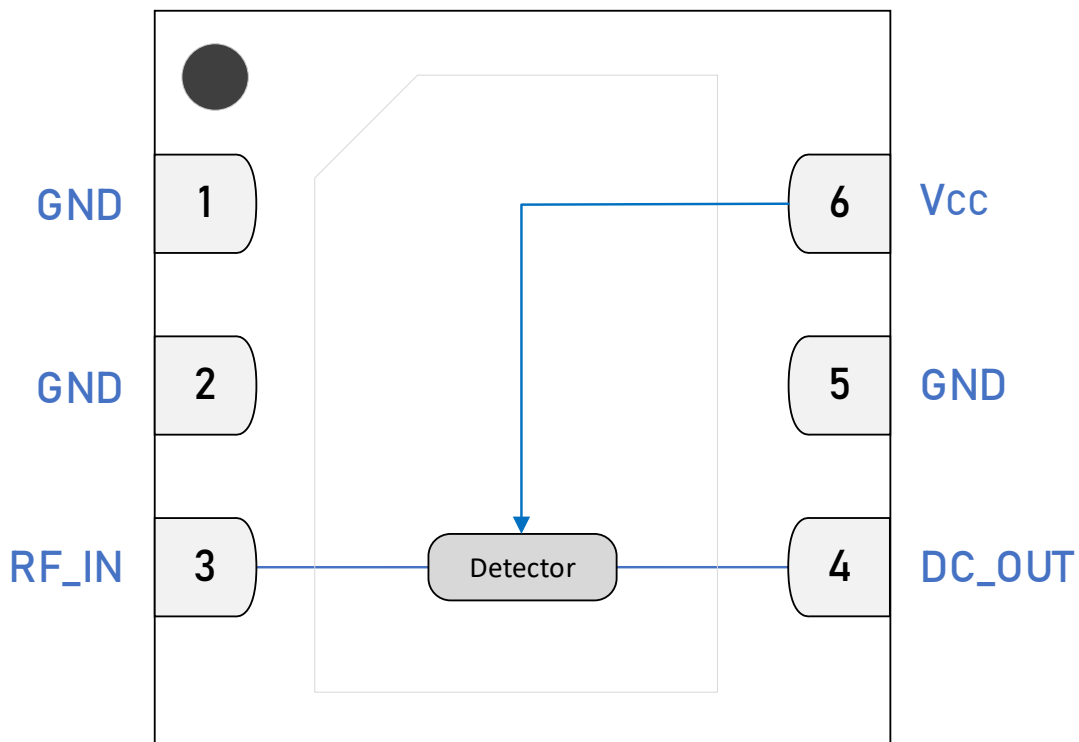

1.5 x 1.5 mm DFN-6 Pin Out (Top View)

Pin Assignments

Pin	Name	Description	Note
1, 2, 5	GND/NC	Ground or No Connect	No internal connection to die. We recommend these pins be connected to ground.
3	RF_IN	Detector RF Input	An external DC block must be used.
4	DC_OUT	Detector DC Output	DC coupled to measure detected output power.
6	V _{CC}	Supply Voltage Input	V _{CC} must be supplied through a choke to this pin.
PKG BASE	GND	Ground	Provides DC and RF ground for detector, as well as thermal heat sink. Recommend multiple 8 mil vias beneath the package for optimal RF and thermal performance. Refer to evaluation board top layer graphic on schematic page.

Absolute Ratings

Parameter	Symbol	Min.	Max.	Unit
Supply Voltage	V_{CC}	0	6	V
RF Input Power: Load VSWR < 2:1, Modulation: CW	$P_{IN\ MAX}$		22	dBm
RF Input Power: Load VSWR < 2:1, Modulation: LTE	$P_{IN\ MAX}$		18	dBm
Operating Temperature (package base)	$T_{PKG\ BASE}$	-40	105	°C
Maximum Channel Temperature (MTTF > 10 ⁶ hours)	T_{MAX}		170	°C

Electrostatic Discharge

Human Body Model	HBM	500		V
------------------	-----	-----	--	---

Storage

Storage Temperature	T_{STG}	-65	150	°C
Moisture Sensitivity Level	MSL		1	–



Caution! ESD Sensitive Device

Exceeding Absolute Maximum Rating conditions may cause permanent damage to the device.

Note: For additional information, please refer to [Package Manufacturing Information | Guerrilla RF \(guerrilla-rf.com\)](#)



All Guerrilla RF products are provided in RoHS compliant lead (Pb)-free packaging requiring no exemptions. Additional information for this topic can be found at this link - [Environmental and Restricted Substance Statement Library](#)



Recommended Operating Conditions

Parameter	Symbol	Specification			Unit	Condition
		Min.	Typ.	Max.		
Supply Voltage	V_{CC}	0	5	6	V	
Operating Temperature (package base)	$T_{PKG\ BASE}$	-40		105	°C	
RF Frequency Range	F_{RF}	0.01	2	6	GHz	Typical application schematic with external matching components (notes 1 & 2).
RF_IN Port Impedance	Z_{RF_IN}		50		Ω	Single-ended.

Note 1: Operation outside this range is possible, but with degraded performance of some parameters.

Note 2: Contact the Guerrilla RF Applications team for guidance on optimizing the tuning of the device for alternative bands.

Nominal Operating Parameters – General

The following conditions apply unless noted otherwise: typical application schematic using the 0.1 to 6 GHz tuning set, $V_{CC} = 5\text{ V}$, $I_{CC} = 7\text{ mA}$, $F_{TEST} = 2\text{ GHz}$, $50\ \Omega$ system impedance, $T_{PKG\ BASE} = 25\text{ }^{\circ}\text{C}$. Evaluation Board losses are included within the specifications.

Parameter	Symbol	Specification			Unit	Condition
		Min.	Typ.	Max.		
Test Frequency (50 ohm source)	F_{TEST}		2		GHz	$V_{CC} = 5\text{ V}$.
Supply Current	I_{CC}		7	9	mA	$V_{CC} = 5\text{ V}$.
DC_Out (no RF applied)	DC_Out		0.8		V	
DC_Out (-20 dBm RF Input Power)	DC_Out		1		V	
DC_Out (0 dBm RF Input Power)	DC_Out		2.6		V	
DC_Out (10 dBm RF Input Power)	DC_Out		3.5		V	
DC_Out (20 dBm RF Input Power)	DC_Out		4.3		V	
Detector Output Rise Time	T_{RISE}		200		ns	
Detector Output Fall Time	T_{FALL}		650		ns	
Maximum Die Temperature (Infrared Scan) Package Base Temperature = $85\text{ }^{\circ}\text{C}$	T_{MAX}		96		$^{\circ}\text{C}$	$V_{CC} = 5\text{ V}$. Input matching resistor = $68\ \Omega$. RF Input Power = 20 dBm.

Thermal Data

Thermal Resistance (Infrared Scan)	Θ_{JC}		TBD		$^{\circ}\text{C}/\text{W}$	On standard evaluation board (note 3).
------------------------------------	---------------	--	-----	--	-----------------------------	---

Note 3: MTF $> 10^6$ hours for $T_J \leq 170\text{ }^{\circ}\text{C}$.

GRF1201 Typical Operating Curves: Pin = -20 to +20 dBm

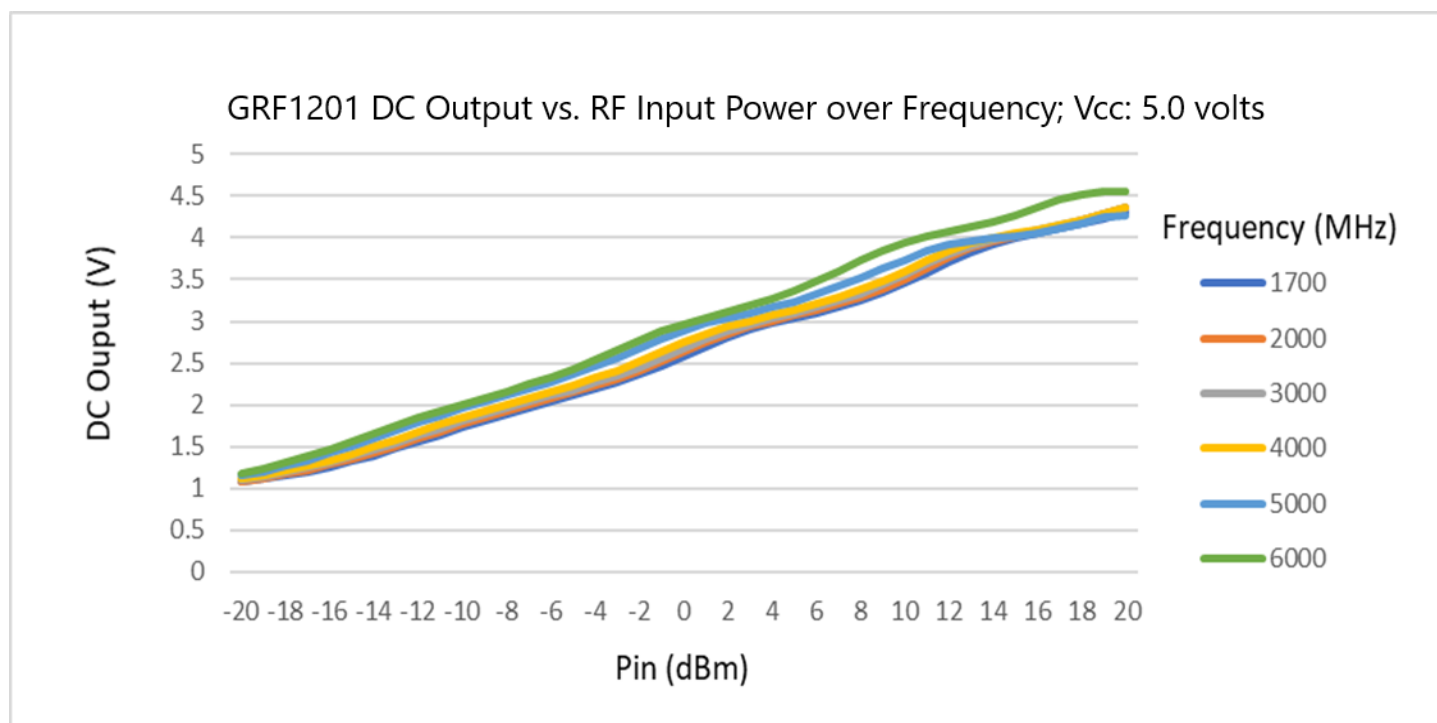
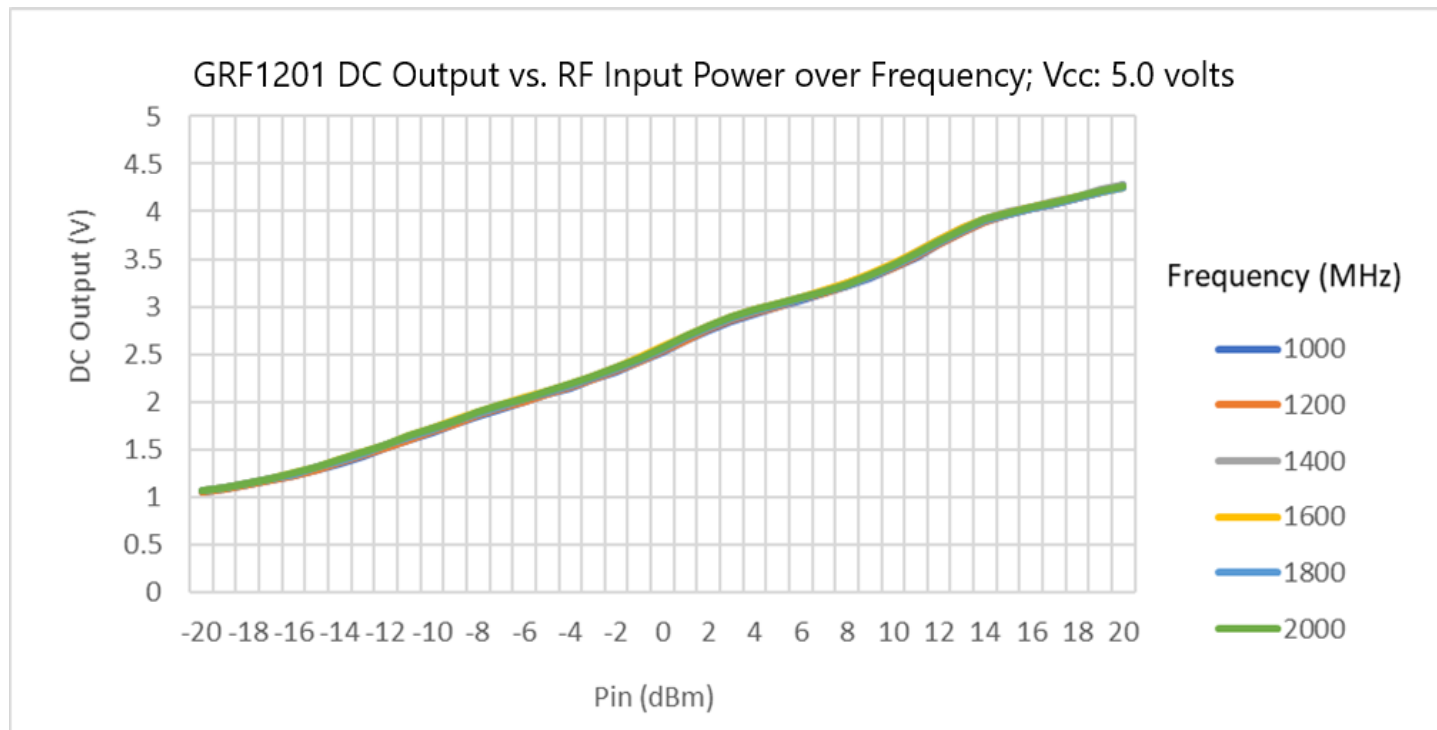

GRF1201 Typical Operating Curves: Pin = -20 to +20 dBm

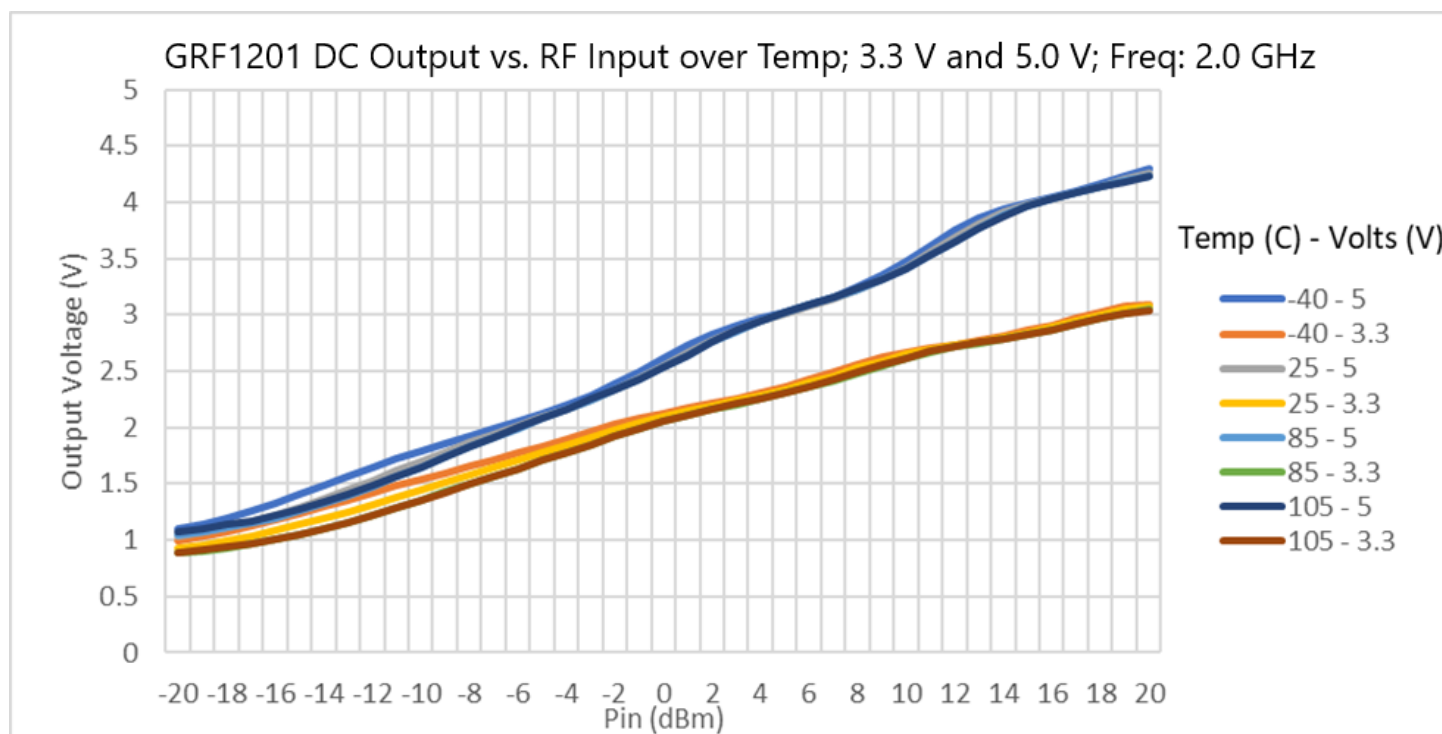
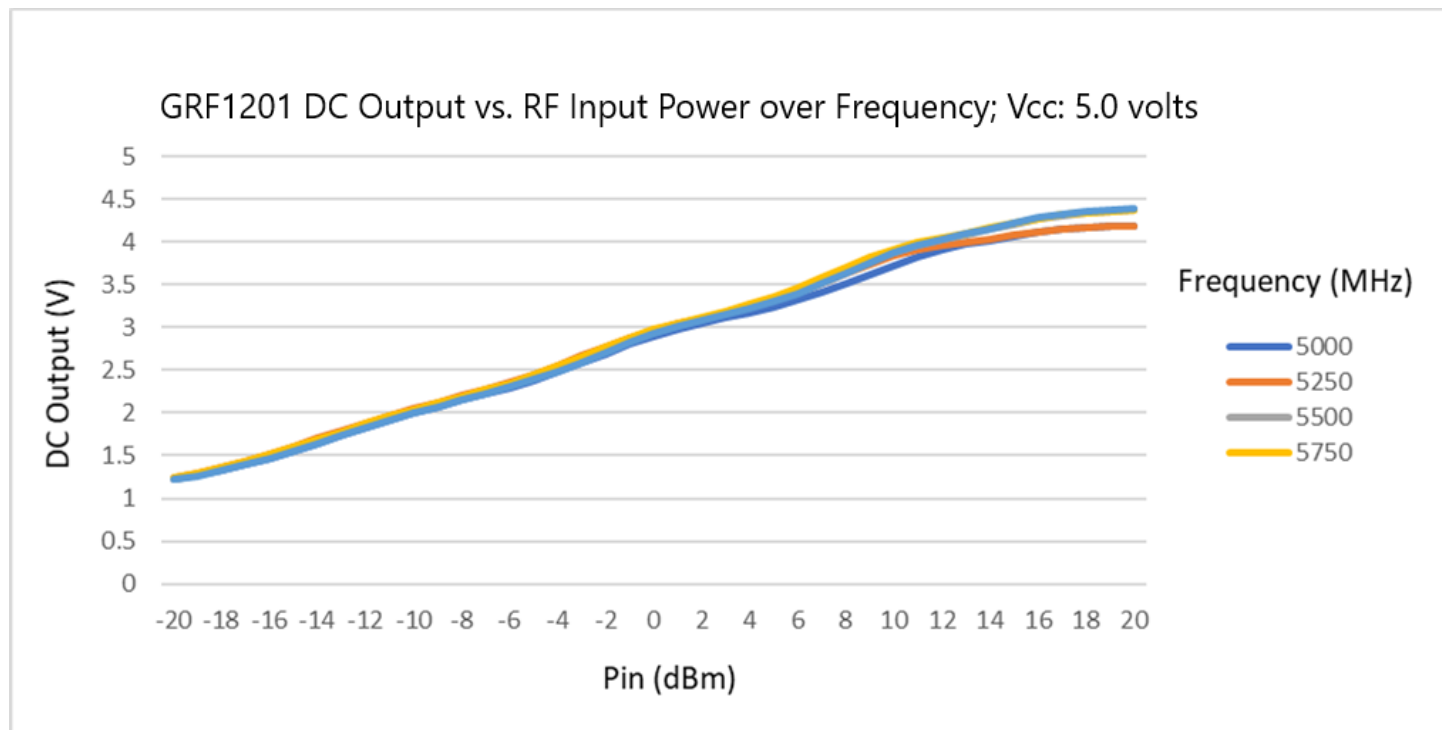

GRF1201 Typical Operating Curves: Pin = -20 to +20 dBm (M2 = 2 pF)

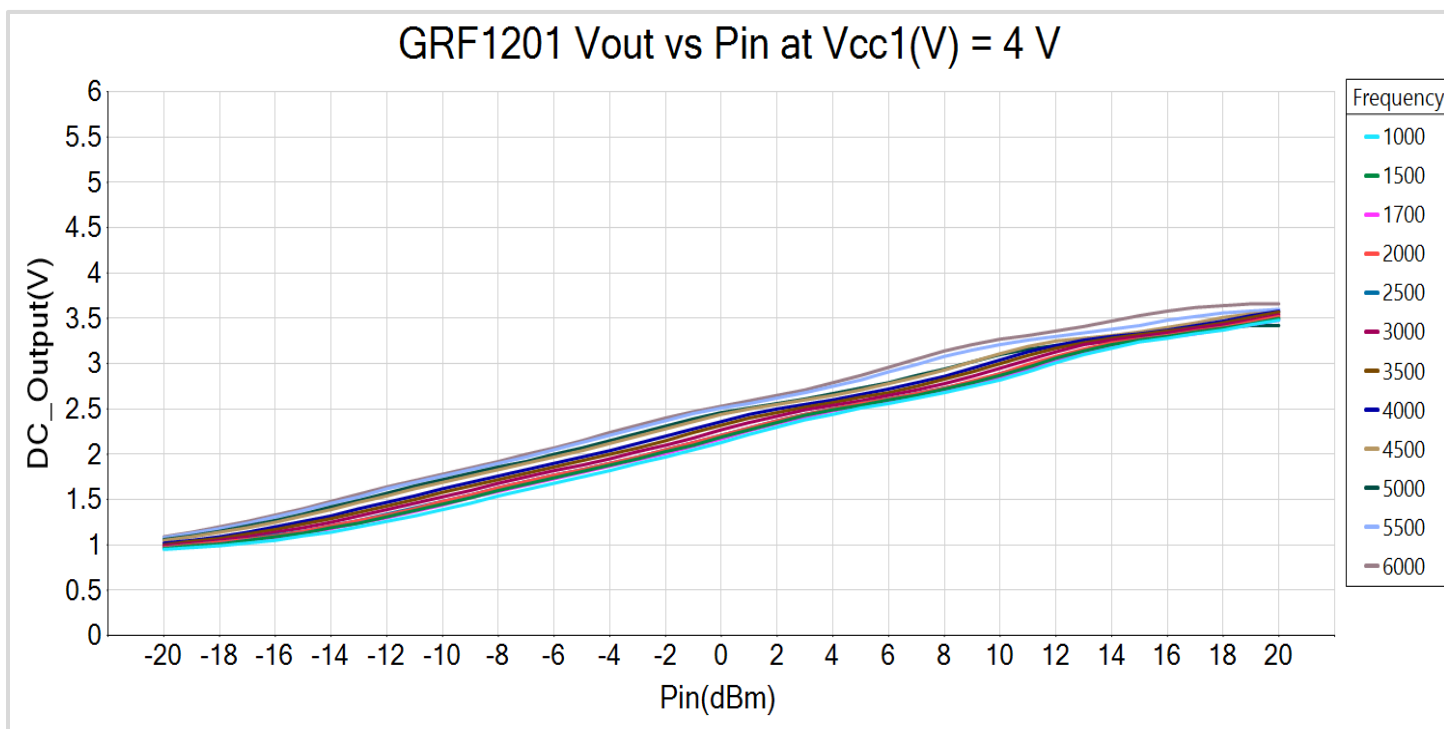
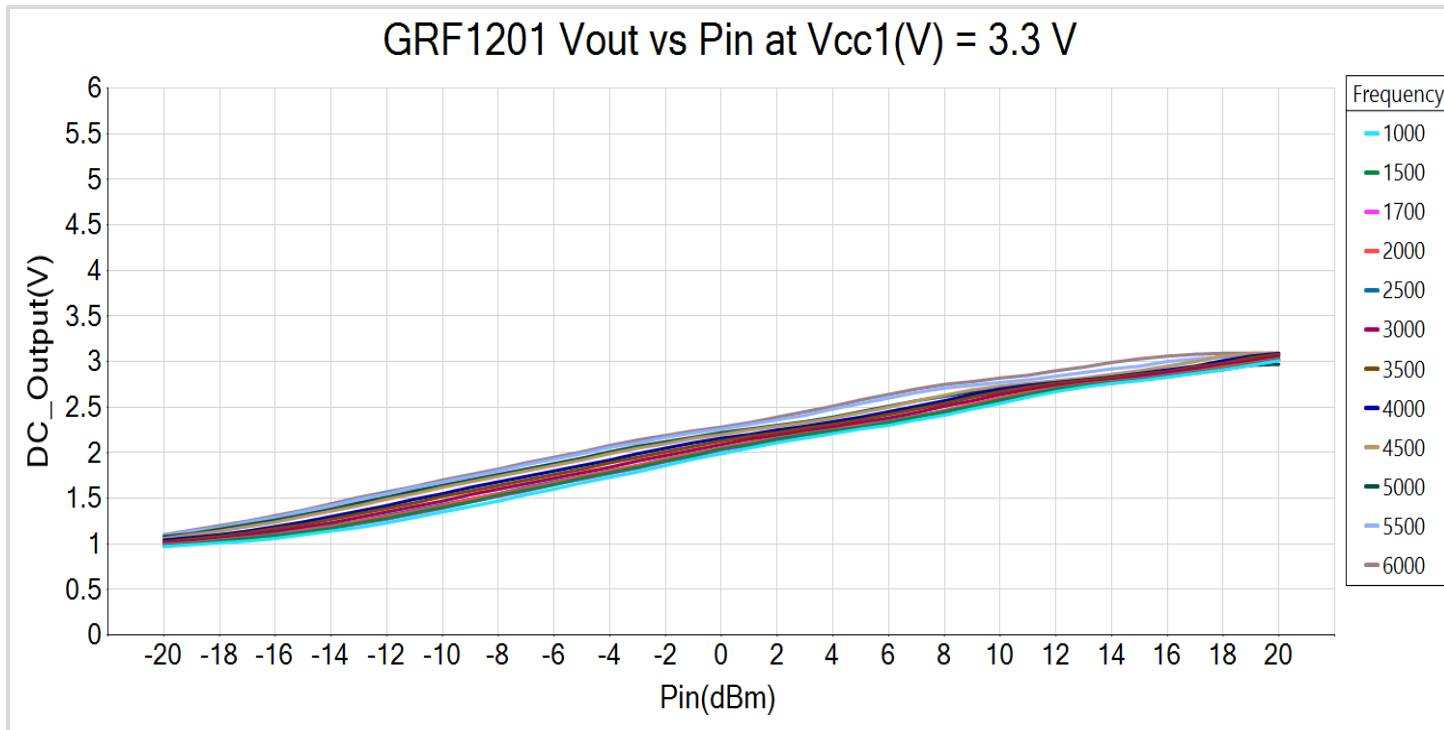

GRF1201 Typical Operating Curves: Pin = -20 to +20 dBm (M2 = 2 pF)

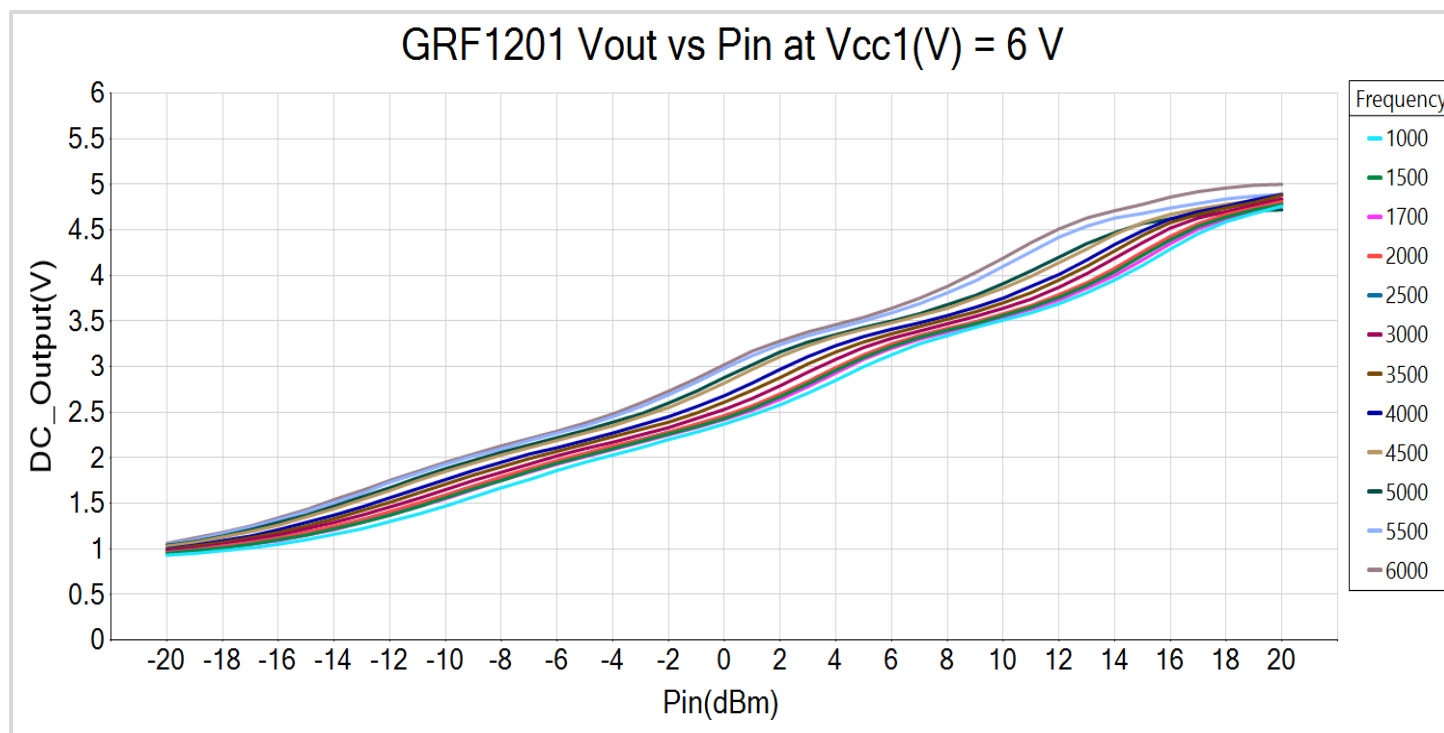
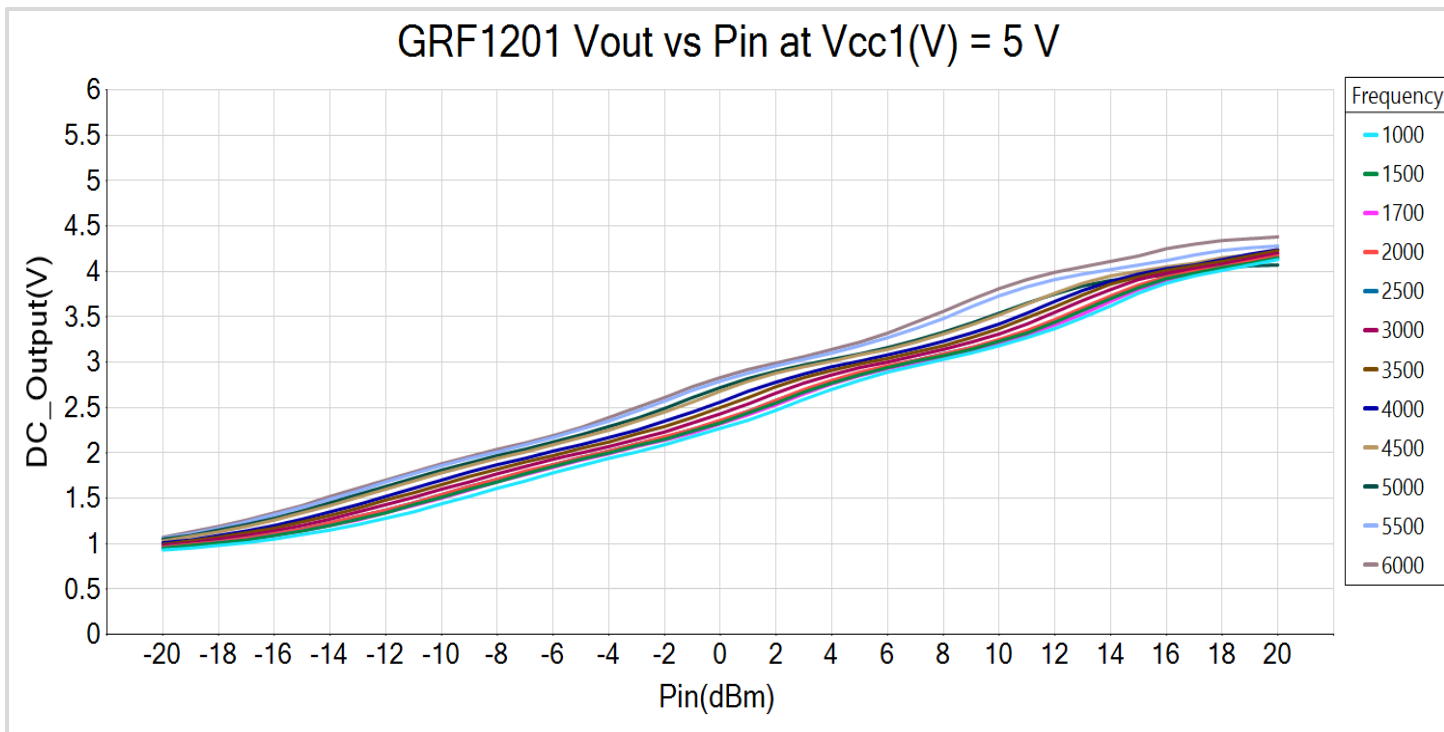

GRF1201 Typical Operating Curves: Pin = -20 to +20 dBm (M2 = 100 pF)

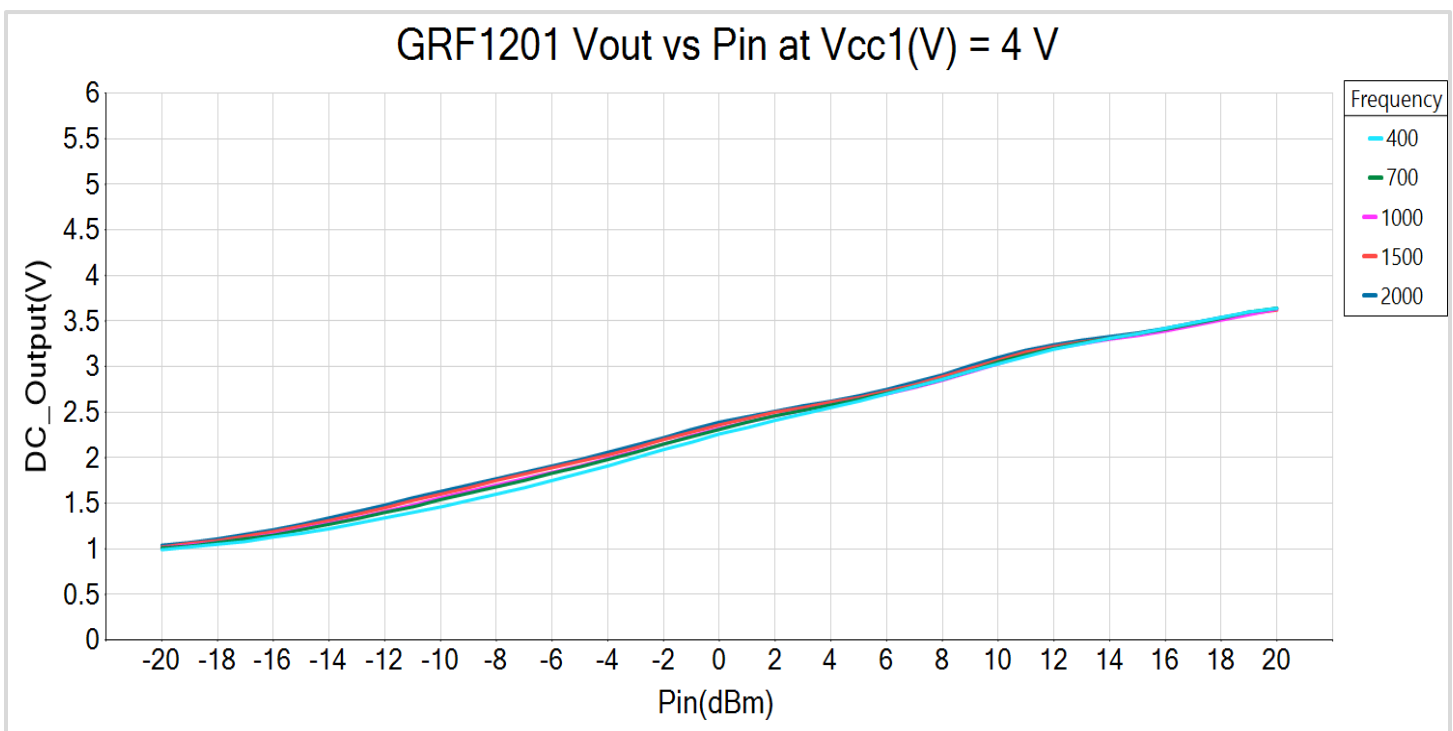
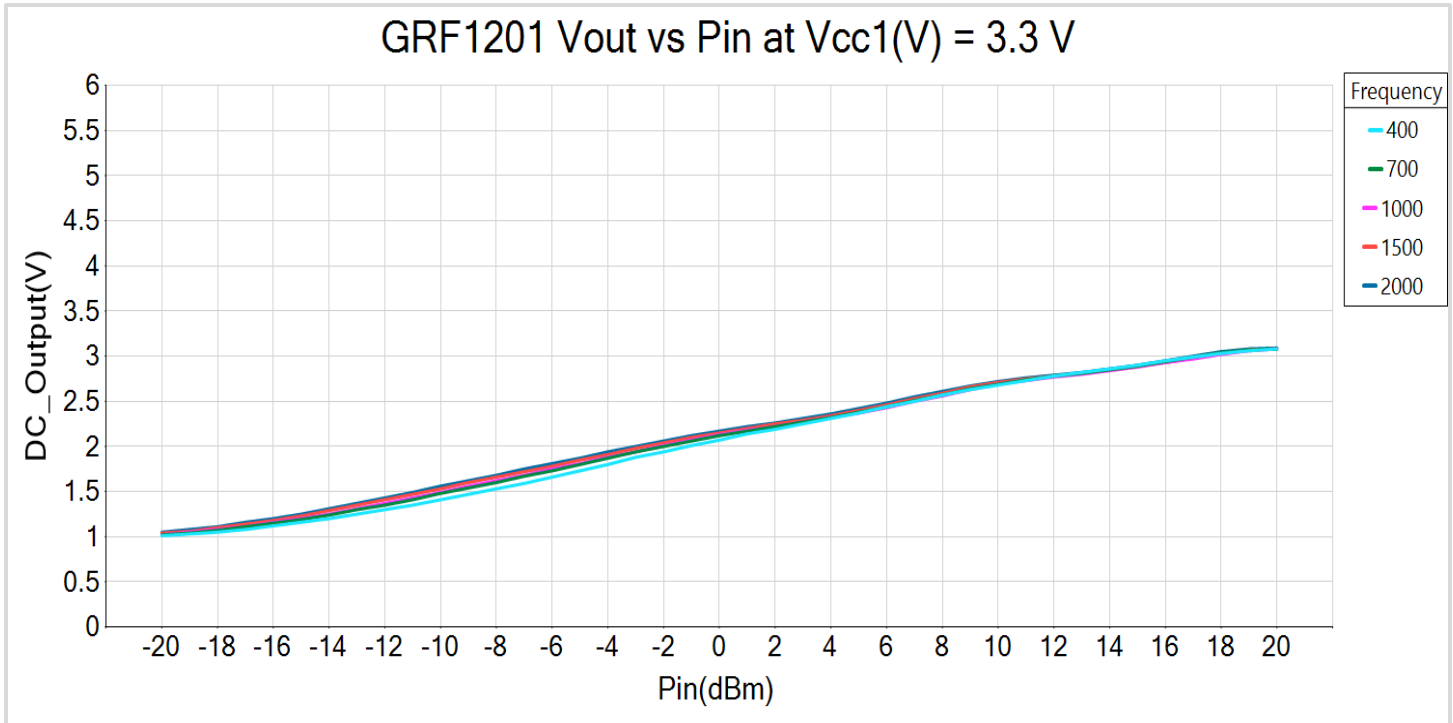

GRF1201 Typical Operating Curves: Pin = -20 to +20 dBm (M2 = 100 pF)

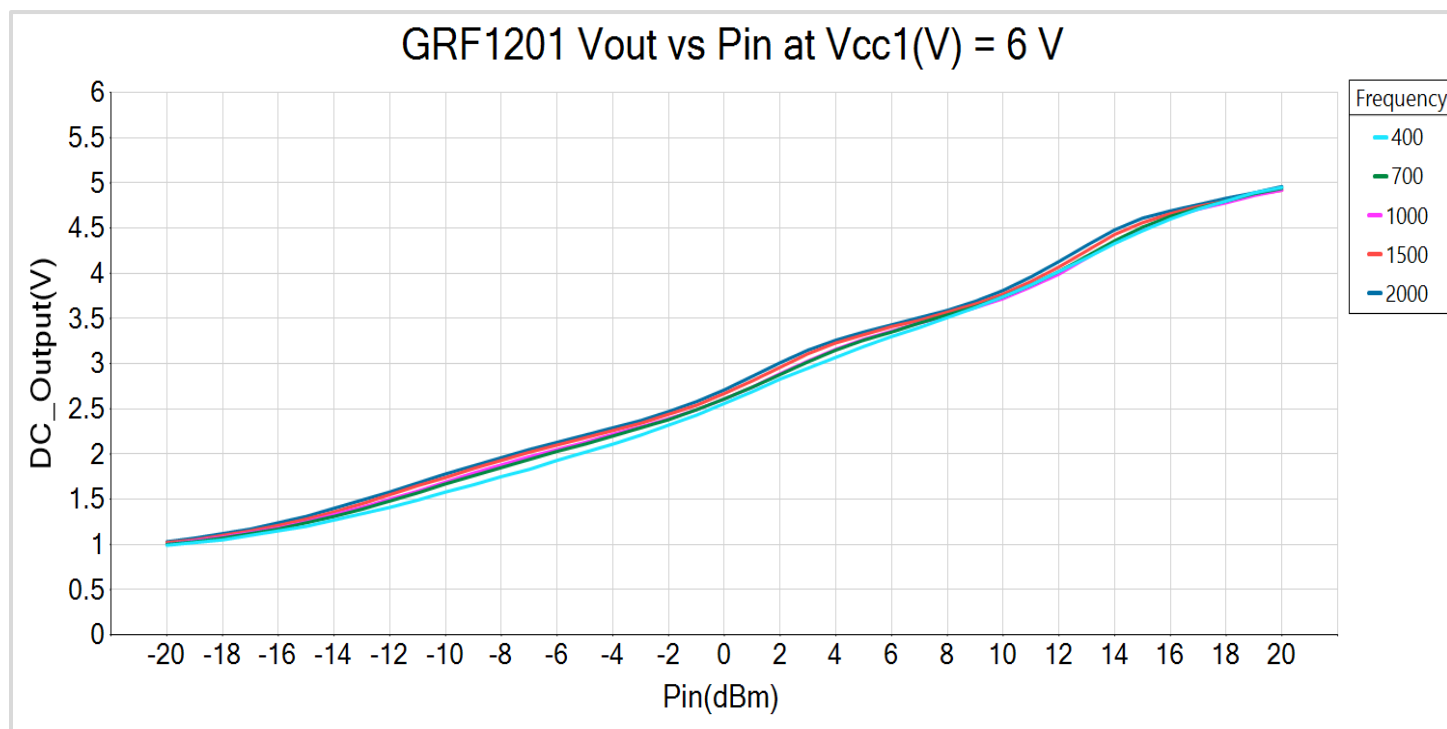
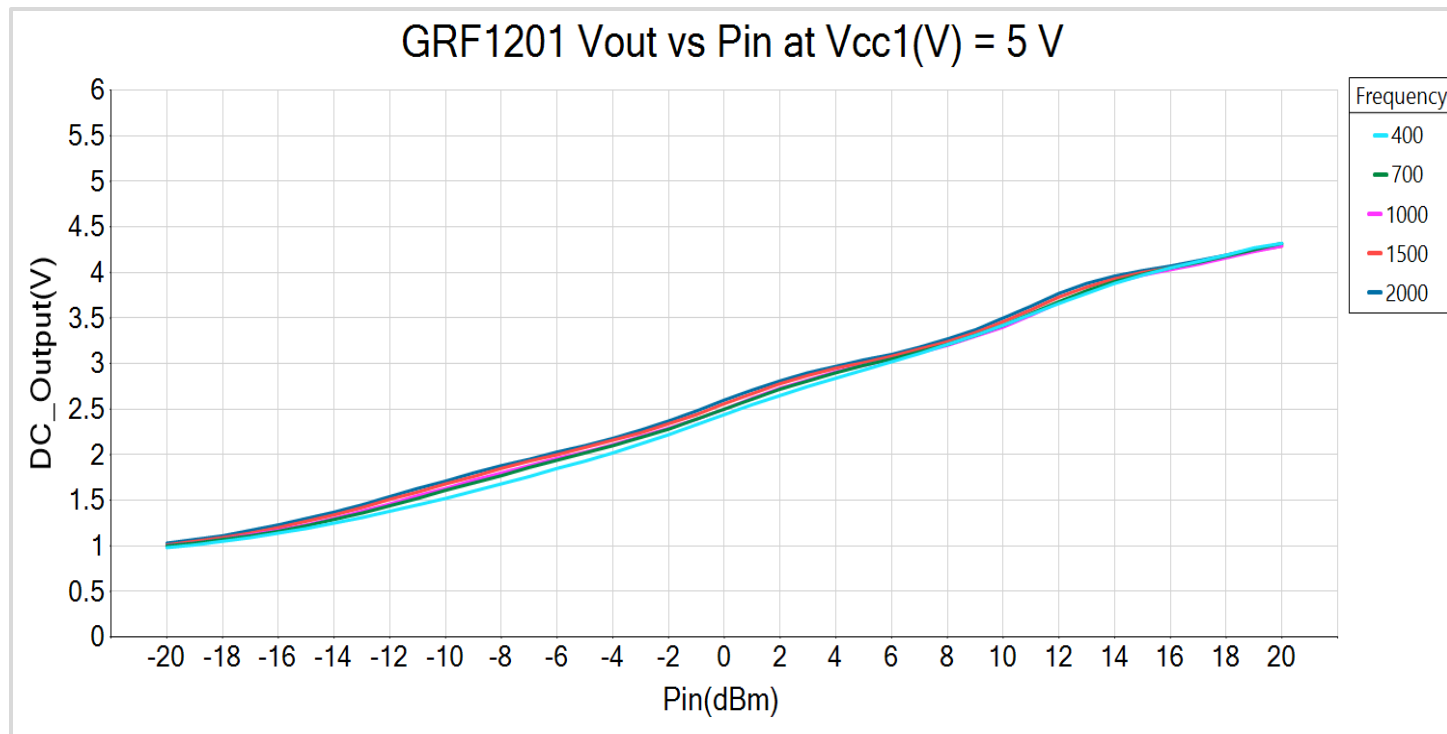

GRF1201 Detector Rise and Fall Times

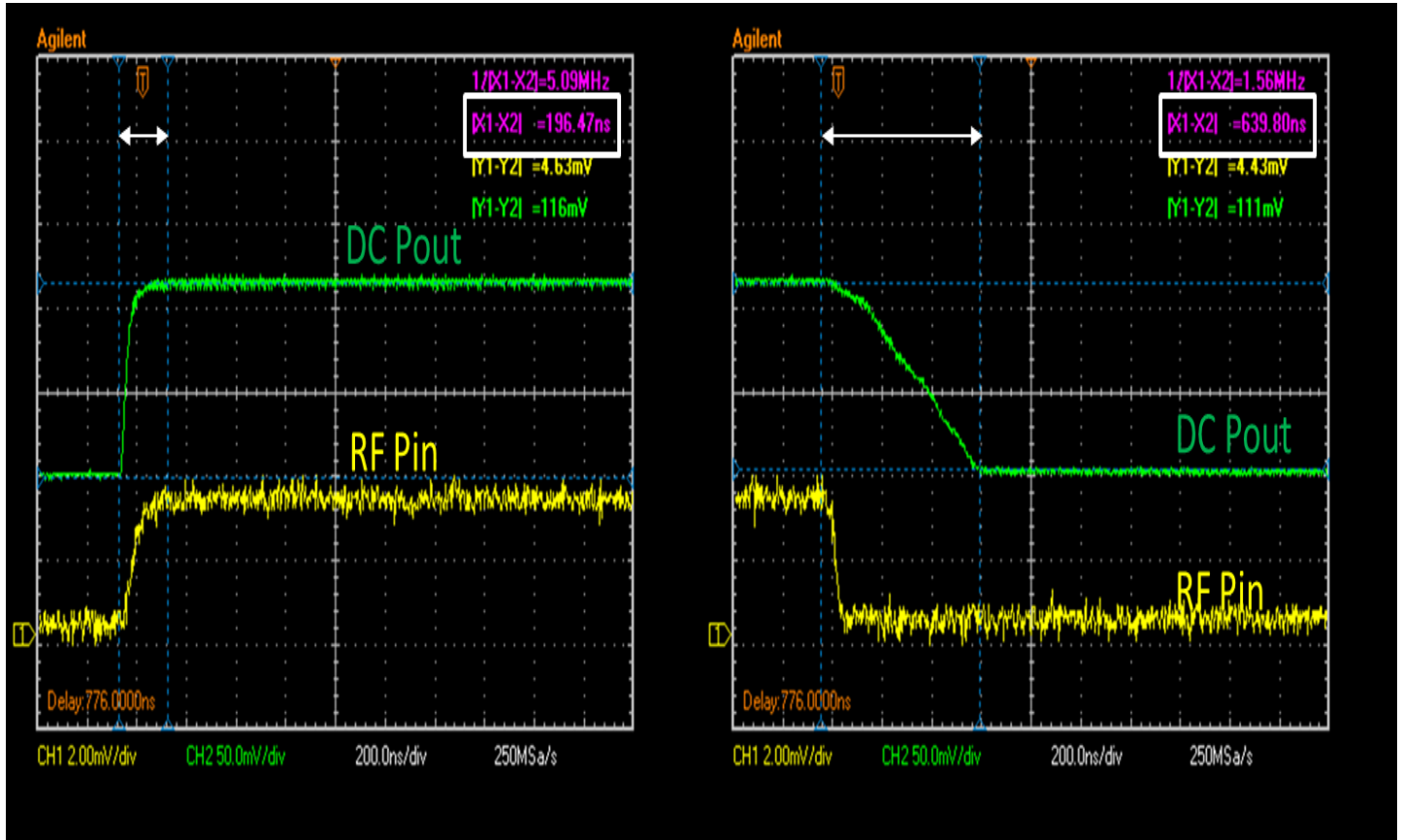

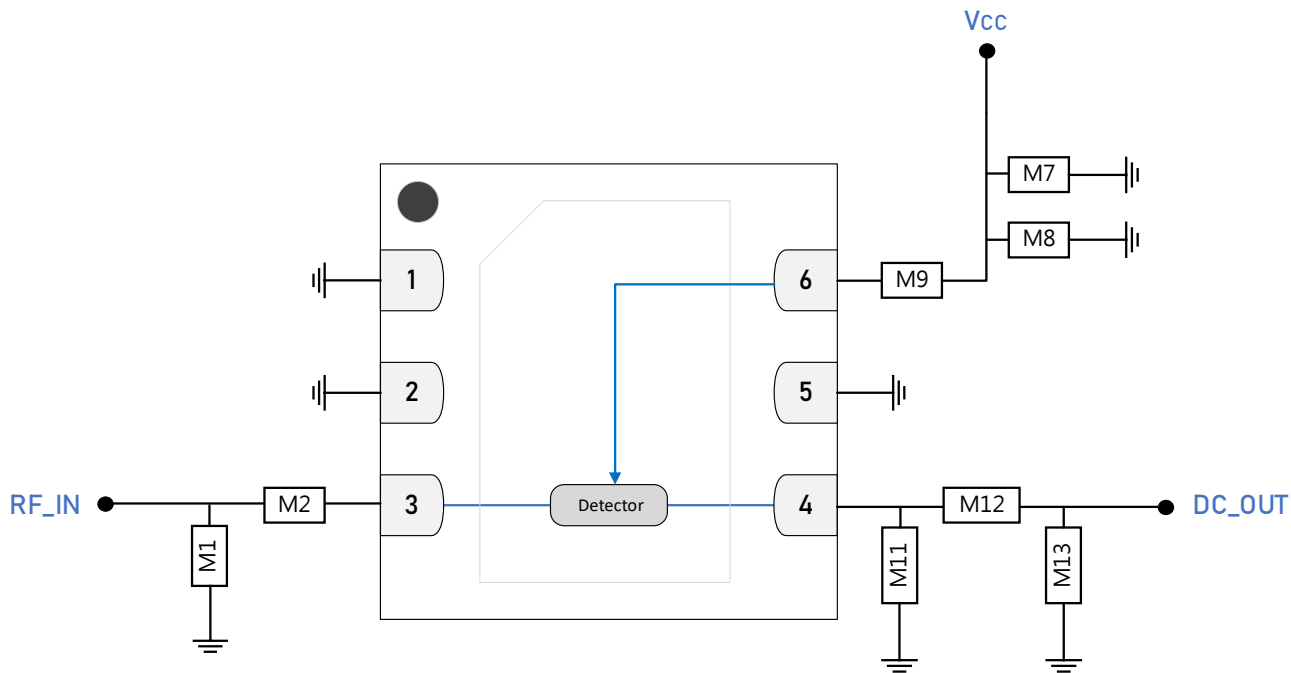

GRF1201 Standard Evaluation Board Schematic

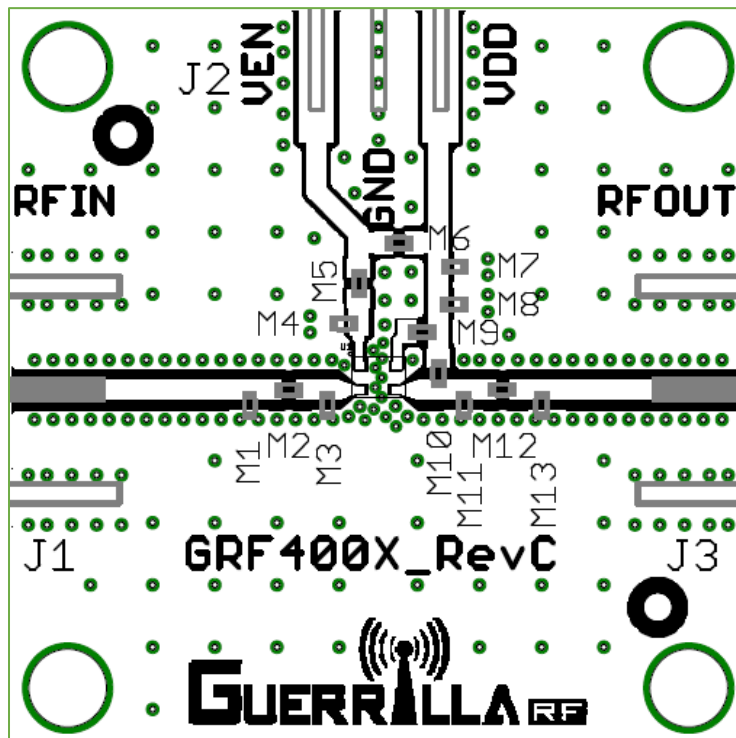

GRF1201 Evaluation Board Assembly Diagram

GRF1201 Evaluation Board Assembly Diagram Reference: 5 V, 25 mA

Component	Type	Manufacturer	Family	Value	Package Size	Substitution
M1	Resistor	Various	5%	68 Ω	0402	ok
M2 (0.1 to 4 GHz)*	Capacitor	Murata	GRM	470 pF	0402	ok
M2 (0.4 to 1 GHz)*	Capacitor	Murata	GRM	100 pF**	0402	ok
M2 (1 to 6 GHz)*	Capacitor	Murata	GRM	2.0 pF	0402	ok
M7	Capacitor	Murata	GRM	0.1 μ F	0402	ok
M8	Capacitor	Murata	GRM	100 pF	0402	ok
M9	Resistor (jumper)	Various	5%	0 Ω	0402	ok
M11	Capacitor	Murata	GRM/GJM	100 pF	0402	ok
M12	Resistor (jumper)	Various	5%	0 Ω	0402	ok
M13	Resistor	Various	5%	10 k Ω	0402	ok
Evaluation Board	GRF400X_RevC					

Notes:

*M2 value is flexible and only needs to be a good RF short at the frequency of interest. All other evaluation board assembly diagram reference components are not frequency dependent.

** Standard evaluation board M2 value is 100 pF.

Package Marking Diagram



- Line 1: "Y" = YEAR (single digit). "WW" = WORK WEEK the device was assembled.
- Line 2: "XXXX" = Device Part Number.

Tape and Reel Information

Guerrilla RF's tape and reel specification complies with Electronics Industries Alliance (EIA) standards for "Embossed Carrier Tape of Surface Mount Components for Automatic Handling" (reference EIA-481). See the following page for the Tape and Reel Specification and Device Package Information table, which includes units per reel.

Devices are loaded with pins down into the carrier pocket with protective cover tape and reeled onto a plastic reel. Each reel is packaged in a cardboard box. There are product labels on the reel, the protective ESD bag and the outside surface of the box.

For the Tape and Reel Reference Table, please refer to: [Package Manufacturing Information | Guerrilla RF \(guerrilla-rf.com\)](#)

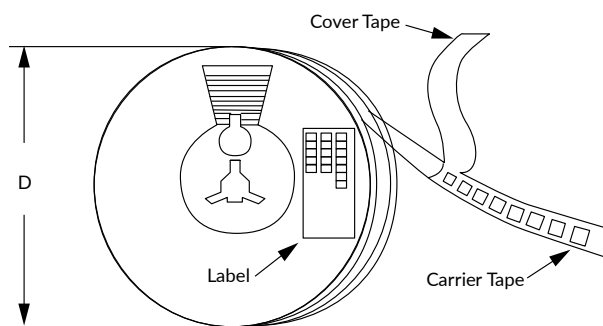

Tape and Reel Packaging with Reel Diameter Noted (D)

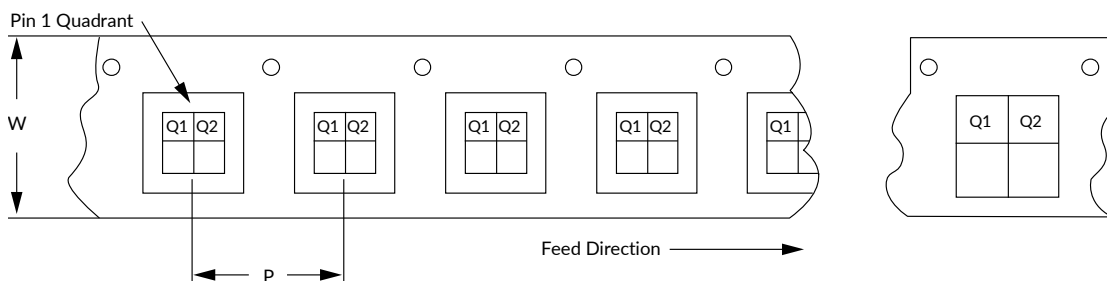

Carrier Tape Width (W), Pitch (P), Feed Direction and Pin 1 Quadrant Information



Revision History

Revision Date	Description of Change
July 29, 2020	Preliminary Data Sheet.
March 15, 2021	Release \emptyset Data Sheet.
January 31, 2022	Release A Data Sheet. Upgraded Data Sheet to new format.
February 12, 2024	Upgraded Data Sheet to newest format only. No change to device or device specifications.
March 21, 2024	Added Thermal Resistance specification.
May 28, 2025	Extended lower frequency range from 100 MHz to 10 MHz.
August 28, 2025	Added plots with M2 capacitor values.
September 17, 2025	Converted Data Sheet to new format. No change to device or device specifications.



Data Sheet Classifications

Data Sheet Status	Notes
Advance	S-parameter and NF data based on EM simulations for the fully packaged device using foundry-supplied transistor S-parameters. Linearity estimates based on device size, bias condition and experience with related devices.
Preliminary	All data based on limited evaluation board measurements taken within the Guerrilla RF Applications Lab. All parametric values are subject to change pending the collection of additional data.
Release Ø	All data based on measurements taken with <i>production-released</i> material. TYP values are based on a combination of ATE and bench-level measurements, with MIN/MAX limits defined using <i>modelled estimates</i> that account for part-to-part variations and expected process spreads. Although unlikely, future refinements to the TYP/MIN/MAX values may be in order as multiple lots are processed through the factory.
Release A-Z	All data based on measurements taken with production-released material <i>derived from multiple lots which have been fabricated over an extended period of time</i> . MIN/MAX limits may be refined over previous releases as more statistically significant data is collected to account for process spreads.

Information in this data sheet is specific to the Guerrilla RF, Inc. ("Guerrilla RF") product identified.

This data sheet, including the information contained in it, is provided by Guerrilla RF as a service to its customers and may be used for informational purposes only by the customer. Guerrilla RF assumes no responsibility for errors or omissions on this data sheet or the information contained herein. Information provided is believed to be accurate and reliable, however, no responsibility is assumed by Guerrilla RF for its use, nor for any infringement of patents, or other rights of third parties, resulting from its use. Guerrilla RF assumes no liability for any data sheet, data sheet information, materials, products, product information, or other information provided hereunder, including the sale, distribution, reproduction or use of Guerrilla RF products, information, or materials.

No license, whether express, implied, by estoppel, by implication or otherwise is granted by this data sheet for any intellectual property of Guerrilla RF, or any third party, including without limitation, patents, patent rights, copyrights, trademarks, and trade secrets. All rights are reserved by Guerrilla RF.

All information herein, products, product information, data sheets, and data sheet information are subject to change and availability without notice. Guerrilla RF reserves the right to change component circuitry, recommended application circuitry and specifications at any time without prior notice. Guerrilla RF may further change its data sheet, product information, documentation, products, services, specifications, or product descriptions at any time, without notice. Guerrilla RF makes no commitment to update any materials or information and shall have no responsibility whatsoever for conflicts, incompatibilities, or other difficulties arising from any future changes.

GUERRILLA RF INFORMATION, PRODUCTS, PRODUCT INFORMATION, DATA SHEETS AND DATA SHEET INFORMATION ARE PROVIDED "AS IS" AND WITHOUT WARRANTY OF ANY KIND, WHETHER EXPRESS, IMPLIED, STATUTORY, OR OTHERWISE, INCLUDING FITNESS FOR A PARTICULAR PURPOSE OR USE, MERCHANTABILITY, PERFORMANCE, QUALITY OR NON-INFRINGEMENT OF ANY INTELLECTUAL PROPERTY RIGHT; ALL SUCH WARRANTIES ARE HEREBY EXPRESSLY DISCLAIMED. GUERRILLA RF DOES NOT WARRANT THE ACCURACY OR COMPLETENESS OF THE INFORMATION, TEXT, GRAPHICS OR OTHER ITEMS CONTAINED WITHIN THESE MATERIALS. GUERRILLA RF SHALL NOT BE LIABLE FOR ANY DAMAGES, INCLUDING BUT NOT LIMITED TO ANY SPECIAL, INDIRECT, INCIDENTAL, STATUTORY, OR CONSEQUENTIAL DAMAGES, INCLUDING WITHOUT LIMITATION, LOST REVENUES OR LOST PROFITS THAT MAY RESULT FROM THE USE OF THE MATERIALS OR INFORMATION, WHETHER OR NOT THE RECIPIENT OF MATERIALS HAS BEEN ADVISED OF THE POSSIBILITY OF SUCH DAMAGE.

Customers are solely responsible for their use of Guerrilla RF products in the Customer's products and applications or in ways which deviate from Guerrilla RF's published specifications, either intentionally or as a result of design defects, errors, or operation of products outside of published parameters or design specifications. Customers should include design and operating safeguards to minimize these and other risks. Guerrilla RF assumes no liability or responsibility for applications assistance, customer product design, or damage to any equipment resulting from the use of Guerrilla RF products outside of stated published specifications or parameters.