



Copyright FCI



FCIconnect.com

PRODUCT NUMBER  
SEE SHEET 2

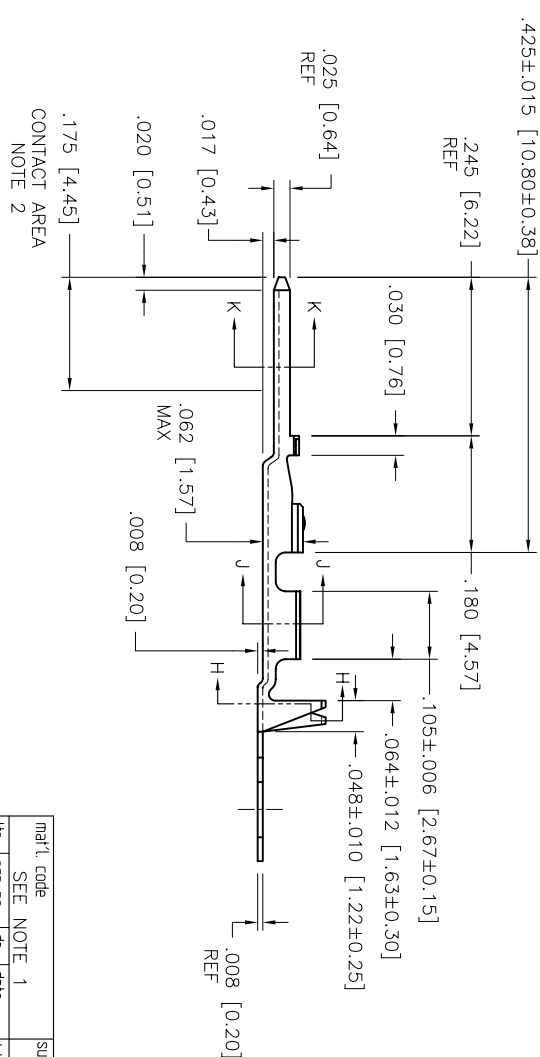
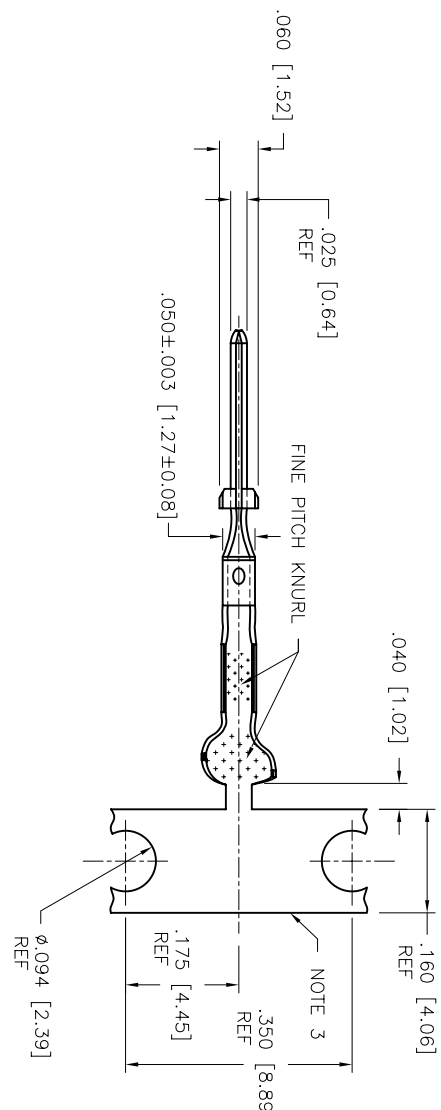

Mat'l code	SEE NOTE 1	surface	tolerance	projection	product family
lfr	ecm no.	dr	date	intolerances unless otherwise specified	PV TERMINAL
M	V41701	LSS	1994-12-22	angles	C.T.W. MALE PIN
N	V04-0056	VS	2004-02-17	XXX 4.005/XXX.13	Sheet 1 of 3
P	V05-0254	HTB	2005-03-18	XXX 4.020/XXX.051	size
R	V06-0583	HTB	2006-06-27	M.CLOUSER	A4
S	V08-0114	HTB	2008-04-01	T.HANNA	CUSTOMER Drawing
				T.HANNA	
				1994-08-22	
Sheet	revision	S	S		
Index	Sheet	1	2	3	



Copyright FCI



FCIconnect.com



PRODUCT NUMBER		AWG	DIM A	DIM B	DIM C	DIM D	DIM E	DIM F
REELED FOR APPLICATION MACHINES FEEDING								
LEFT - RIGHT	RIGHT - LEFT							
47791-003	47791-000			O B S O L E T T E				
47791-003LF	47791-000LF	28-32	.054 [1.37]	.058 [1.47]	.011 [0.28]	.115 [2.92]	.105 [2.67]	.040 [1.02]
47792-003	47792-000			O B S O L E T T E				
47792-003LF	47792-000LF	22-26	.070 [1.78]	.065 [1.65]	.017 [0.43]	.139 [3.53]	.120 [3.05]	.050 [1.27]
47793-003	47793-000			O B S O L E T T E				
47793-003LF	47793-000LF	18-20	.104 [2.64]	.104 [2.64]	.021 [0.53]	.139 [3.53]	.120 [3.05]	.050 [1.27]

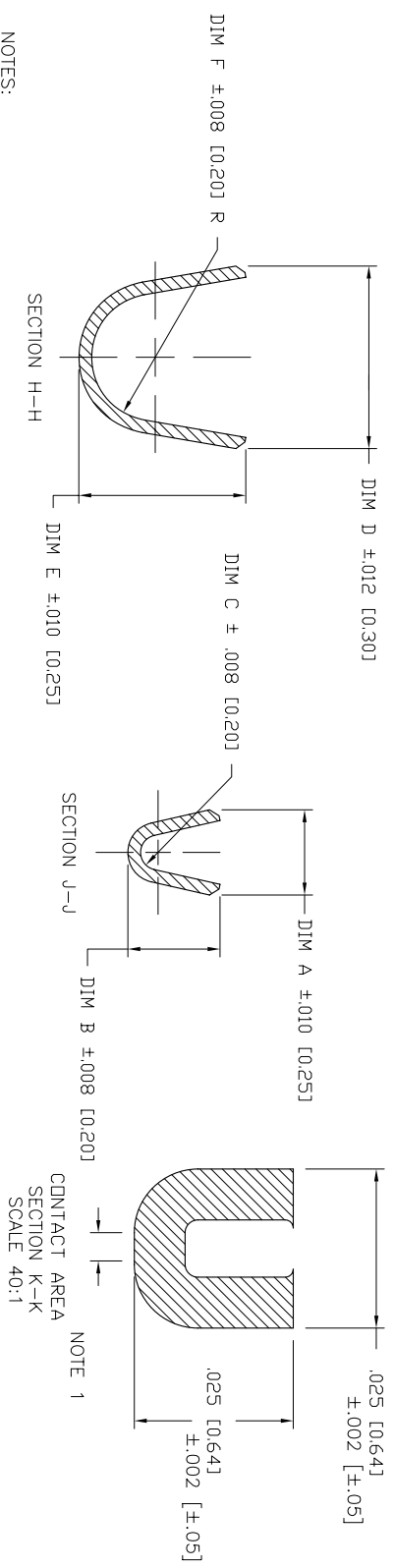

NOTES:

- MATERIAL: C2600 CARTRIDGE BRASS, 3/4 HD.
- PLATING: ELECTRODEPOSITED GOLD - 50u"/1.27u AVG. THICKNESS IN CONTACT AREA. REMAINDER GOLD FLASH. UNDERPLATE 50u"/1.27u NICKEL.
- FOR MANUFACTURING PURPOSES ONLY.
- TERMINAL MAY BE USED WITH MINI LATCH HOUSING.
- APPLICABLE SPECIFICATION:
  - A. BUS-12-098 PRODUCT SPECIFICATION.
  - B. TA-211 CRIMP SPECIFICATION.
- PRODUCT MEETS EUROPEAN UNION DIRECTIVES AND OTHER COUNTRY REGULATIONS AS DESCRIBED IN GS-22-008.
- THIS PRODUCT IS NOT INTENDED TO BE EXPOSED TO MANUFACTURING SOLDER PROCESSES.

Mat'l code	SEE NOTE 1	surface	tolerance	projection	product family
lbr	ecm no	dr	date	INCH/MM	PV TERMINAL
S		angles	tolerances unless otherwise specified	Scale 10:1	C.T.W. MALE PIN
		dr	XXXX *0020/XXX*051		
		dr	M.CLOUSER 1994-08-22		
		dr	T.HANNA 1994-08-22		
		dr	T.HANNA 1994-08-22		
		dr	T.HANNA 1994-08-22		
Sheet index	revision	Sheet			



dwg no 47791  
sheet 2 of 3  
size A4  
CUSTOMER Drawing

PRODUCT NUMBER  
SEE SHEET 2

Copyright FCI

FCI  
FCIconnect.com

1 2

3

4

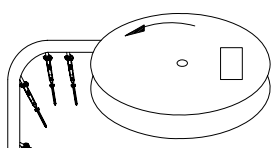

Unreeing Direction  
Left to Right Into  
Applicator

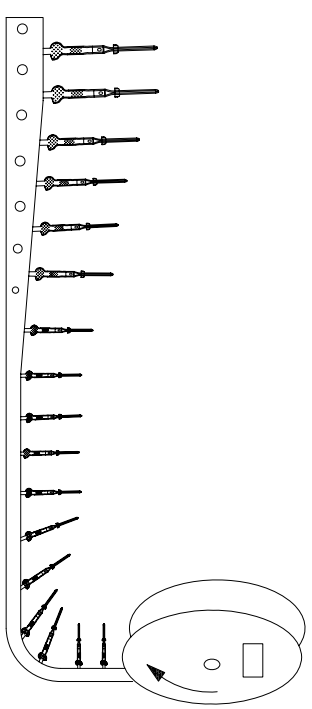

Unreeing Direction  
Right to Left Into  
Applicator

mat'l. code	SEE NOTE 1	surface	<input checked="" type="checkbox"/> tolerance	projection	product family
litr	ecm no	dr	date	INCH	PV TERMINAL
S		angles	tolerances unless otherwise specified	Scale 1:1	C.T.W. MALE PIN
		dr	XXXX-0020/XXX-051		Sheet 3 of 3
		dr	H. SUNDY 2004-02-17		Size A4
		dr	H. SUNDY 2004-02-17		
		dr	H. SUNDY 2004-02-17		
		dr	H. SUNDY 2004-02-17		
sheet	revision				
index	sheet				

Form: A4mmX1c

1

2

3

4