

NOTES:

1. MATERIALS AND FINISHES:
 - BODY - BRASS, NICKEL PLATING
 - CONTACT - BeCu, GOLD PLATING
 - BULLET CONTACT - BRASS, GOLD PLATING
 - INSULATORS - PTFE, NATURAL
 - COUPLING NUT - BRASS, NICKEL PLATING
 - GASKET - SILICON RUBBER, RED
 - FERRULE - COPPER, NICKEL PLATING
 - HEAT SHRINK TUBING - CROSSLINKED POLYOLEFIN
2. ELECTRICAL:
 - A. IMPEDANCE: 50 OHM
 - B. FREQUENCY RANGE: DC - 6 GHz
 - C. DIELECTRIC WITHSTANDING VOLTAGE: 1000 VRMS, MIN.
3. MECHANICAL:
 - A. DURABILITY: 500 CYCLES MIN.
 - B. TEMPERATURE RANGE: -65° C TO +165° C
4. PACKAGING:
 - A. QUANTITY: SINGLE PACK
 - B. MARKING: BAG TO BE MARKED "AMPHENOL RF, 82-6553, AND DATE CODE"
5. RECOMMENDED CABLE ASSEMBLY INSTRUCTIONS:
 - A. TRIM CABLE AS SHOWN.
 - B. SLIDE HEAT SHRINK TUBING, FERRULE AND INSULATOR DISC ONTO CABLE.
 - C. SOLDER CABLE CENTER CONDUCTOR TO CONTACT.
 - D. INSERT CABLE WITH FOIL ENTERING CONNECTOR AND BRAID OVER KNURL.
 - E. CRIMP FERRULE OVER BRAID WITH 0.429" HEX DIE.
 - F. APPLY HEAT SHRINK TUBING OVER FERRULE.
 - G. HEAT SHRINK TUBING SHOULD FULLY (360 DEG) COVER THE BUMP ON BODY AND END WITHIN AREA "A"
6. RECOMMENDED COUPLING TORQUE : 6-10 IN-LBS.

THIRD ANGLE PROJ.

REVISIONS

REV	DESCRIPTION	DATE	ECO	APPR
A	RELEASE TO MFG	24-Sep-12	49140	DD
B	ADDED ARC LOGO TO COUPLING NUT & AMPHENOL RF TO HST RD-DMI3022001R3	1-Mar-13	49418	RM
C	CRIMP WAS 0.532"	12-Feb-15	50404	JN

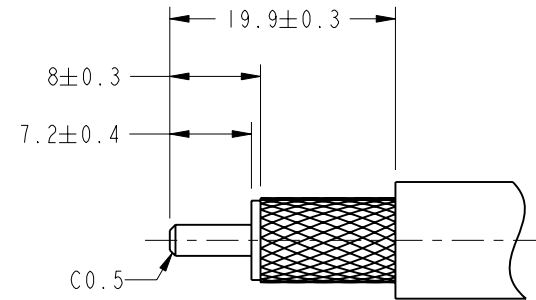

SCALE 1.500

RECOMMENDED CABLE STRIPPING

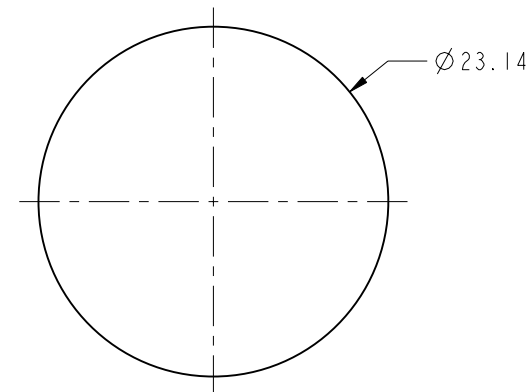

MIN PASS THRU DIAMETER

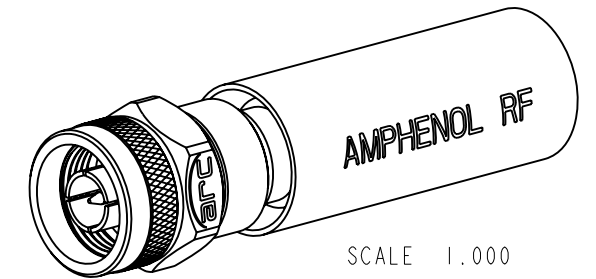

SCALE 1.000

7. SHOW CABLE ENTRY DIMENSIONS.

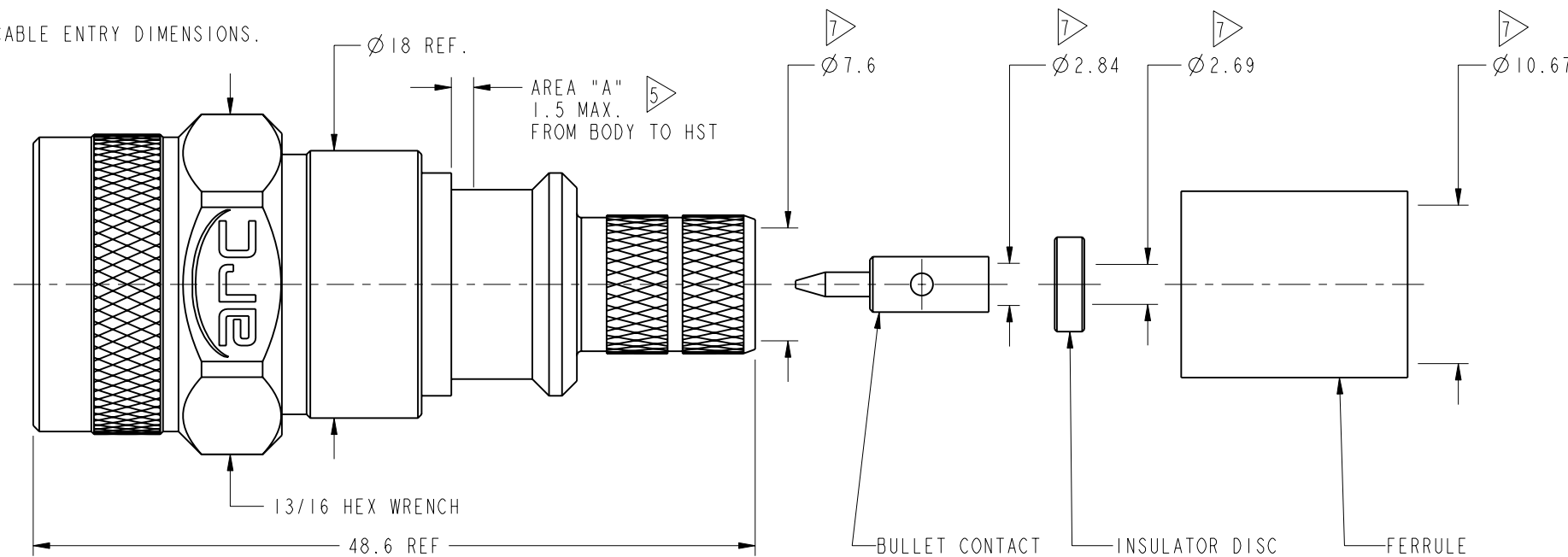

INTERFACE PER MIL-STD-348 SERIES:N PLUG

CUSTOMER OUTLINE DRAWING

ALL OTHER SHEETS ARE FOR INTERNAL USE ONLY

UNLESS OTHERWISE SPECIFIED, DIMENSIONS ARE IN METRIC AND TOLERANCES ARE: < 0.5mm ± 0.05mm 0.5 - 6mm ± 0.1mm 6 - 30mm ± 0.2mm 30 - 120mm ± 0.3mm ANGLES ± 1°	MATERIAL	DRAWN	DATE	TITLE N STR PLUG IP-67 FOR LMR-400 CABLE		Amphenol RF Danbury CT USA, Tainan, Taiwan, Shenzhen, China www.amphenolrf.com	
	SEE NOTES	S. DUAN	06-Mar-15				
NOTICE - These drawings, specifications, or other data (1) are, and remain the property of Amphenol corp. (2) must be returned upon request; and (3) are confidential and not to be disclosed to any person other than those to whom they are given by Amphenol Corp. the furnishing of these drawings, specifications, or other data by Amphenol Corp., or to any other person to anyone for any purpose is not to be regarded by implication or otherwise in any manner licensing, granting rights to permitting such holder or any other person to manufacture, use or sell any product, process or design, patented or otherwise, that may in any way be related to or disclosed by said drawings, specifications, or other data.	REFERENCE	ENGINEER	DATE	SCALE: 2.3:1.0 SHEET 2 OF 2		DRAWING NO. 82-6553 ITEM NO. 82-6553 PART NO. 82-6553	
	82-6451 AND EAR3408	D. DAVE	15-Sep-11				
	CONFIGURATION LEVEL:	APPROVED	S. HSIEH	09-Mar-15	DWG SIZE	REV	
FINISH				B	C		