



General Description

The AP2138N-xxTRG1 series is a set of three-terminal low power high voltage regulators implemented in CMOS technology. They allow input voltages as high as 15V. The series features extremely low quiescent current which is typically 2uA. They are available with several fixed output voltages ranging from 1.5V to 5.0V. CMOS technology ensures low voltage drop and low quiescent current. Although designed primarily as fixed voltage regulators, these devices can be used with external components to obtain variable voltages and currents.

Features

- Low Power Consumption
- Low Voltage Drop
- Low temperature coefficient
- Ultra low quiescent current: 2uA(typ.)
- High input voltage (up to 15V)
- Maximum output current: 250mA
- Output Voltage Accuracy: tolerance $\pm 2\%$
- SOT-23 package

Application

- Battery-powered Equipments
- Communication Equipments
- Audio/Video Equipments

Pin Configuration And Descriptions

SOT-23 (Top View)

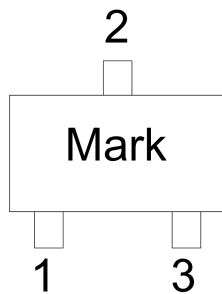

Table1:AP2138N-xxTRG1 series (SOT-23 PKG)

PIN NO.	PIN NAME	FUNCTION
1	GND	GND pin
2	VIN	Input voltage pin
3	VOUT	Output voltage pin

Order Information

Orderable Device	Package	Output Voltage	Packing Option
AP2138N-xxTRG1	SOT-23	1.5V 1.8V 2.5V 2.8V 3.0V 3.3V 3.6V 4.0V 4.4V 5.0V	3000/Reel

xx : From 1.5-5.0



Absolute Maximum Ratings

Description	Symbol	Value Range	Unit
Supply Voltage	V_{IN}	-0.3~+18	V
Storage Temperature Range	T_{STG}	-50~+125	°C
Operating Free-air Temperature Range	T_A	-30~+85	°C

Note: Stresses greater than those listed under “Absolute Maximum Ratings” cause permanent damage to the device. These are stress ratings only, and functional operation of the device at these or any other conditions beyond those indicated under “Recommended Operating Conditions” is not implied. Exposure to “Absolute Maximum Ratings” for extended periods may affect device reliability.

Heat Dissipation

Description	Symbol	Package	Value Range	Unit
Thermal resistance	J_A	SOT-23	500	°C/W
Power dissipation	P_W	SOT-23	0.2	W

Block Diagram

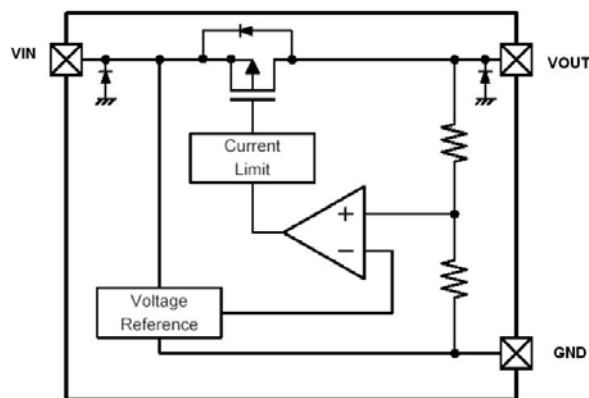

*Diodes inside the circuit are an ESD protection diode and a parasitic diode.



DC Characteristics (unless otherwise noted $T_A = 25^\circ\text{C}$)

AP2138N-1.5TRG1 Output Type

Symbol	Parameter	Test Conditions		Min.	Typ.	Max.	Unit
		V_{IN}	Conditions				
V_{OUT}	Output Voltage	3.5V	$I_{OUT}=40\text{mA}$	1.47	1.50	1.53	V
I_{OUT}	Output Current	3.5V	-	-	250	-	mA
ΔV_{OUT}	Load Regulation	3.5V	$1\text{mA} \leq I_{OUT} \leq 60\text{mA}$	-	45	90	mV
V_{DIF}	Voltage Drop(Note)	-	$I_{OUT}=40\text{mA}, \Delta V_{OUT}=2\%$	-	650	-	mV
I_{SS}	Current Consumption	3.5V	No load	-	2.0	3.0	μA
$\frac{\Delta V_{OUT}}{\Delta V_{IN} \times V_{OUT}}$	Line Regulation	-	$2.5\text{V} \leq V_{IN} \leq 12\text{V}$ $I_{OUT}=40\text{mA}$	-	0.2	-	%/V
V_{IN}	Input Voltage	-	-	-	-	15	V
$\frac{\Delta V_{OUT}}{\Delta T_a}$	Temperature Coefficient	3.5V	$I_{OUT}=40\text{mA}$ $-40^\circ\text{C} < T_a < 85^\circ\text{C}$	-	± 0.5	-	mV/ $^\circ\text{C}$

Note: Dropout voltage is defined as the input voltage minus the output voltage that produces a 2% change in the output voltage from the value at $V_{IN} = V_{OUT} + 1\text{V}$ with a fixed load.

AP2138N-1.8TRG1 Output Type

Symbol	Parameter	Test Conditions		Min.	Typ.	Max.	Unit
		V_{IN}	Conditions				
V_{OUT}	Output Voltage	3.8V	$I_{OUT}=10\text{mA}$	1.764	1.800	1.836	V
I_{OUT}	Output Current	3.8V	-	-	250	-	mA
ΔV_{OUT}	Load Regulation	3.8V	$1\text{mA} \leq I_{OUT} \leq 60\text{mA}$	-	45	90	mV
V_{DIF}	Voltage Drop(Note)	-	$I_{OUT}=40\text{mA}, \Delta V_{OUT}=2\%$	-	620	-	mV
I_{SS}	Current Consumption	3.8V	No load	-	2.0	3.0	μA
$\frac{\Delta V_{OUT}}{\Delta V_{IN} \times V_{OUT}}$	Line Regulation	-	$2.8\text{V} \leq V_{IN} \leq 12\text{V}$ $I_{OUT}=40\text{mA}$	-	0.2	-	%/V
V_{IN}	Input Voltage	-	-	-	-	15	V
$\frac{\Delta V_{OUT}}{\Delta T_a}$	Temperature Coefficient	3.8V	$I_{OUT}=10\text{mA}$ $-40^\circ\text{C} < T_a < 85^\circ\text{C}$	-	± 0.5	-	mV/ $^\circ\text{C}$

Note: Dropout voltage is defined as the input voltage minus the output voltage that produces a 2% change in the output voltage from the value at $V_{IN} = V_{OUT} + 1\text{V}$ with a fixed load.



AP2138N-2.5TRG1 Output Type

Symbol	Parameter	Test Conditions		Min.	Typ.	Max.	Unit
		V _{IN}	Conditions				
V _{OUT}	Output Voltage	4.5V	I _{OUT} =40mA	2.45	2.500	2.55	V
I _{OUT}	Output Current	4.5V	-	-	250	-	mA
ΔV _{OUT}	Load Regulation	4.5V	1mA ≤ I _{OUT} ≤ 60mA	-	45	90	mV
V _{DIF}	Voltage Drop(Note)	-	I _{OUT} =40mA, ΔV _{OUT} =2%	-	550	-	mV
I _{SS}	Current Consumption	4.5V	No load	-	2.0	3.0	μA
$\frac{\Delta V_{OUT}}{\Delta V_{IN} \times V_{OUT}}$	Line Regulation	-	3.5V ≤ V _{IN} ≤ 12V I _{OUT} =40mA	-	0.2	-	%/V
V _{IN}	Input Voltage	-	-	-	-	15	V
$\frac{\Delta V_{OUT}}{\Delta T_a}$	Temperature Coefficient	4.5V	I _{OUT} =40mA -40°C < T _a < 85°C	-	±0.5	-	mV/°C

Note: Dropout voltage is defined as the input voltage minus the output voltage that produces a 2% change in the output voltage from the value at V_{IN} = V_{OUT}+1V with a fixed load.

AP2138N-2.8TRG1 Output Type

Symbol	Parameter	Test Conditions		Min.	Typ.	Max.	Unit
		V _{IN}	Conditions				
V _{OUT}	Output Voltage	4.8V	I _{OUT} =10mA	2.744	2.800	2.856	V
I _{OUT}	Output Current	4.8V	-	-	250	-	mA
ΔV _{OUT}	Load Regulation	4.8V	1mA ≤ I _{OUT} ≤ 60mA	-	45	90	mV
V _{DIF}	Voltage Drop(Note)	-	I _{OUT} =40mA, ΔV _{OUT} =2%	-	520	-	mV
I _{SS}	Current Consumption	4.8V	No load	-	2.0	3.0	μA
$\frac{\Delta V_{OUT}}{\Delta V_{IN} \times V_{OUT}}$	Line Regulation	-	3.8V ≤ V _{IN} ≤ 12V I _{OUT} =40mA	-	0.2	-	%/V
V _{IN}	Input Voltage	-	-	-	-	15	V
$\frac{\Delta V_{OUT}}{\Delta T_a}$	Temperature Coefficient	4.8V	I _{OUT} =10mA -40°C < T _a < 85°C	-	±0.5	-	mV/°C

Note: Dropout voltage is defined as the input voltage minus the output voltage that produces a 2% change in the output voltage from the value at V_{IN} = V_{OUT}+1V with a fixed load



AP2138N-3.0TRG1 Output Type

Symbol	Parameter	Test Conditions		Min.	Typ.	Max.	Unit
		V _{IN}	Conditions				
V _{OUT}	Output Voltage	5V	I _{OUT} =40mA	2.94	3.00	3.06	V
I _{OUT}	Output Current	5V	-	-	250	-	mA
ΔV _{OUT}	Load Regulation	5V	1mA ≤ I _{OUT} ≤ 60mA	-	45	90	mV
V _{DIF}	Voltage Drop(Note)	-	I _{OUT} =40mA, ΔV _{OUT} =2%	-	480	-	mV
I _{SS}	Current Consumption	5V	No load	-	2.0	3.0	μA
$\frac{\Delta V_{OUT}}{\Delta V_{IN} \times V_{OUT}}$	Line Regulation	-	4V ≤ V _{IN} ≤ 12V I _{OUT} =40mA	-	0.2	-	%/V
V _{IN}	Input Voltage	-	-	-	-	15	V
$\frac{\Delta V_{OUT}}{\Delta T_a}$	Temperature Coefficient	5V	I _{OUT} =40mA -40°C < T _a < 85°C	-	±0.5	-	mV/°C

Note: Dropout voltage is defined as the input voltage minus the output voltage that produces a 2% change in the output voltage from the value at V_{IN} = V_{OUT}+1V with a fixed load.

AP2138N-3.3TRG1 Output Type

Symbol	Parameter	Test Conditions		Min.	Typ.	Max.	Unit
		V _{IN}	Conditions				
V _{OUT}	Output Voltage	5.3V	I _{OUT} =40mA	3.234	3.300	3.366	V
I _{OUT}	Output Current	5.3V	-	-	250	-	mA
ΔV _{OUT}	Load Regulation	5.3V	1mA ≤ I _{OUT} ≤ 60mA	-	45	90	mV
V _{DIF}	Voltage Drop(Note)	-	I _{OUT} =40mA, ΔV _{OUT} =2%	-	440	-	mV
I _{SS}	Current Consumption	5.3V	No load	-	2.0	3.0	μA
$\frac{\Delta V_{OUT}}{\Delta V_{IN} \times V_{OUT}}$	Line Regulation	-	4.3V ≤ V _{IN} ≤ 12V I _{OUT} =40mA	-	0.2	-	%/V
V _{IN}	Input Voltage	-	-	-	-	15	V
$\frac{\Delta V_{OUT}}{\Delta T_a}$	Temperature Coefficient	5.3V	I _{OUT} =40mA -40°C < T _a < 85°C	-	±0.5	-	mV/°C

Note: Dropout voltage is defined as the input voltage minus the output voltage that produces a 2% change in the output voltage from the value at V_{IN} = V_{OUT}+1V with a fixed load.



AP2138N-3.6TRG1 Output Type

Symbol	Parameter	Test Conditions		Min.	Typ.	Max.	Unit
		V _{IN}	Conditions				
V _{OUT}	Output Voltage	5.6V	I _{OUT} =40mA	3.528	3.600	3.672	V
I _{OUT}	Output Current	5.6V	-	-	250	-	mA
ΔV _{OUT}	Load Regulation	5.6V	1mA ≤ I _{OUT} ≤ 60mA	-	45	90	mV
V _{DIF}	Voltage Drop(Note)	-	I _{OUT} =40mA, ΔV _{OUT} =2%	-	400	-	mV
I _{SS}	Current Consumption	5.6V	No load	-	2.0	3.0	μA
$\frac{\Delta V_{OUT}}{\Delta V_{IN} \times V_{OUT}}$	Line Regulation	-	4.6V ≤ V _{IN} ≤ 12V I _{OUT} =40mA	-	0.2	-	%/V
V _{IN}	Input Voltage	-	-	-	-	15	V
$\frac{\Delta V_{OUT}}{\Delta Ta}$	Temperature Coefficient	5.6V	I _{OUT} =40mA -40°C < Ta < 85°C	-	±0.5	-	mV/°C

Note: Dropout voltage is defined as the input voltage minus the output voltage that produces a 2% change in the output voltage from the value at V_{IN} = V_{OUT}+1V with a fixed load.

AP2138N-4.4TRG1 Output Type

Symbol	Parameter	Test Conditions		Min.	Typ.	Max.	Unit
		V _{IN}	Conditions				
V _{OUT}	Output Voltage	6.4V	I _{OUT} =40mA	4.312	4.400	4.488	V
I _{OUT}	Output Current	6.4V	-	-	250	-	mA
ΔV _{OUT}	Load Regulation	6.4V	1mA ≤ I _{OUT} ≤ 60mA	-	45	90	mV
V _{DIF}	Voltage Drop(Note)	-	I _{OUT} =40mA, ΔV _{OUT} =2%	-	280	-	mV
I _{SS}	Current Consumption	6.4V	No load	-	2.0	3.0	μA
$\frac{\Delta V_{OUT}}{\Delta V_{IN} \times V_{OUT}}$	Line Regulation	-	5.4V ≤ V _{IN} ≤ 12V I _{OUT} =40mA	-	0.2	-	%/V
V _{IN}	Input Voltage	-	-	-	-	15	V
$\frac{\Delta V_{OUT}}{\Delta Ta}$	Temperature Coefficient	6.4V	I _{OUT} =40mA -40°C < Ta < 85°C	-	±0.5	-	mV/°C

Note: Dropout voltage is defined as the input voltage minus the output voltage that produces a 2% change in the output voltage from the value at V_{IN} = V_{OUT}+1V with a fixed load.



TXAP2138N-5.0TRG1 Output Type

Symbol	Parameter	Test Conditions		Min.	Typ.	Max.	Unit
		V _{IN}	Conditions				
V _{OUT}	Output Voltage	7V	I _{OUT} =40mA	4.9	5.00	5.1	V
I _{OUT}	Output Current	7V	-	-	250	-	mA
ΔV _{OUT}	Load Regulation	7V	1mA ≤ I _{OUT} ≤ 60mA	-	45	90	mV
V _{DIF}	Voltage Drop(Note)	-	I _{OUT} =40mA, ΔV _{OUT} =2%	-	200	-	mV
I _{SS}	Current Consumption	7V	No load	-	2.0	3.0	μA
$\frac{\Delta V_{OUT}}{\Delta V_{IN} \times V_{OUT}}$	Line Regulation	-	6V ≤ V _{IN} ≤ 12V I _{OUT} =40mA	-	0.2	-	%/V
V _{IN}	Input Voltage	-	-	-	-	15	V
$\frac{\Delta V_{OUT}}{\Delta T_a}$	Temperature Coefficient	7V	I _{OUT} =40mA -40°C < T _a < 85°C	-	±0.5	-	mV/°C

Note: Dropout voltage is defined as the input voltage minus the output voltage that produces a 2% change in the output voltage from the value at V_{IN} = V_{OUT}+1V with a fixed load.

Application Circuit

Basic Circuits

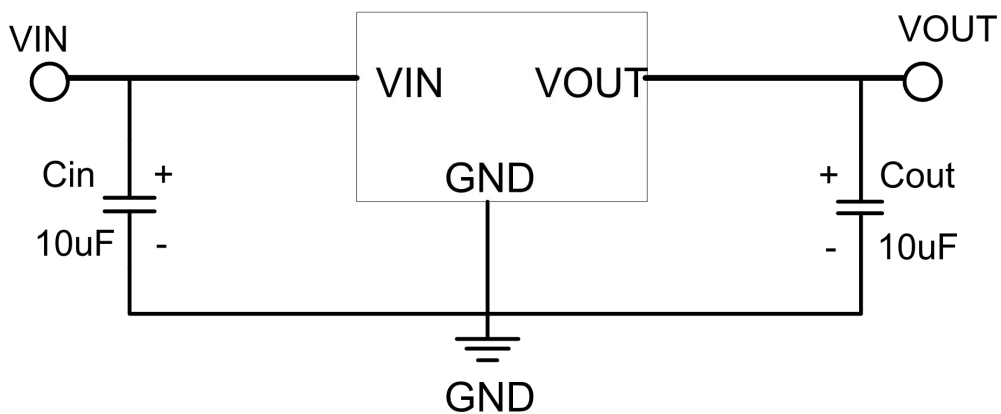

Note1: Cin=Cout=10uF. (10uF Electrolytic capacitor is recommended).

Note2: If the input and output capacitors are ceramic, add a resistor at the input, as follows.

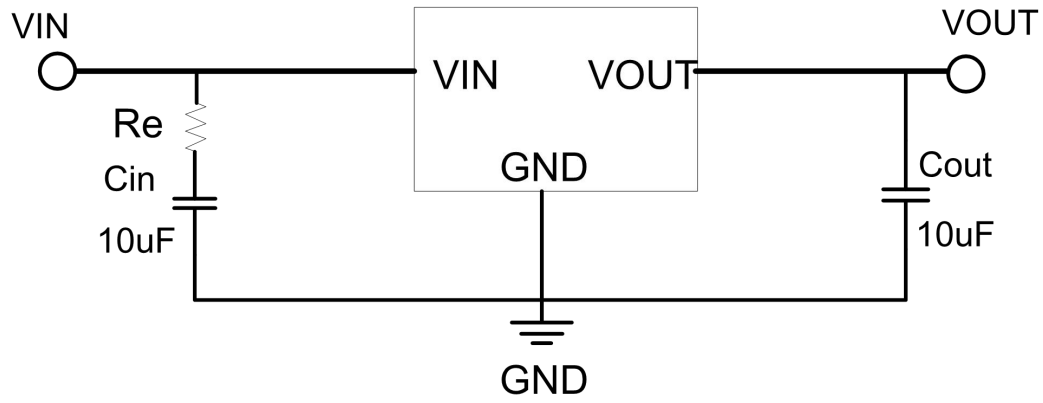

Note: $Re = (1.2 \sim 1.8) \Omega$.



Typical Characteristics

(1) Output Voltage vs Input voltage

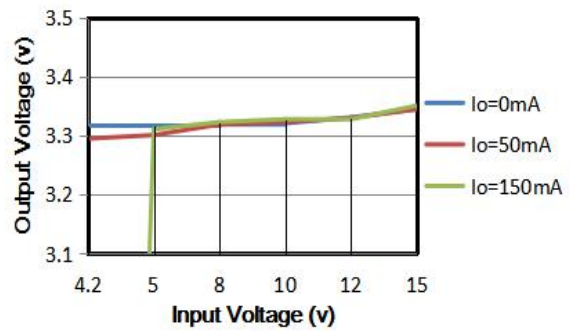
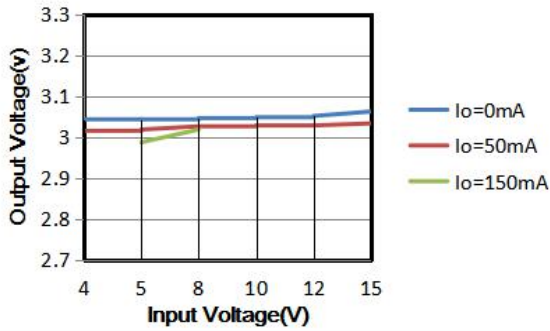

(2) Output Voltage vs. Output Current

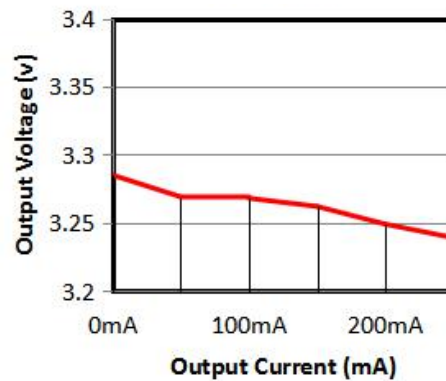
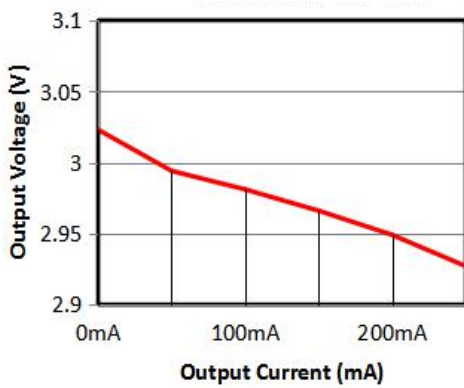

(3) Input Transient Response

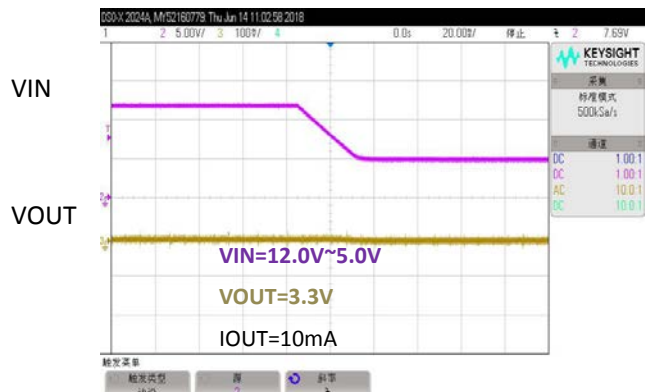
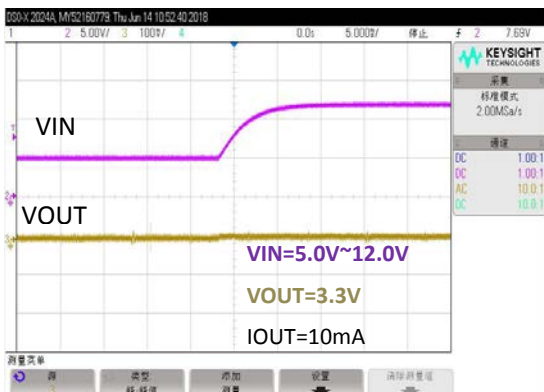



(4) Load Transient Response

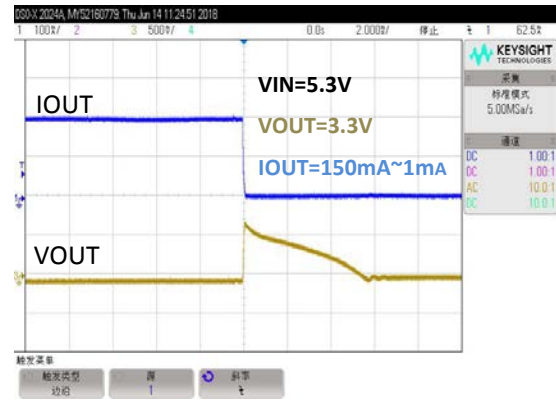
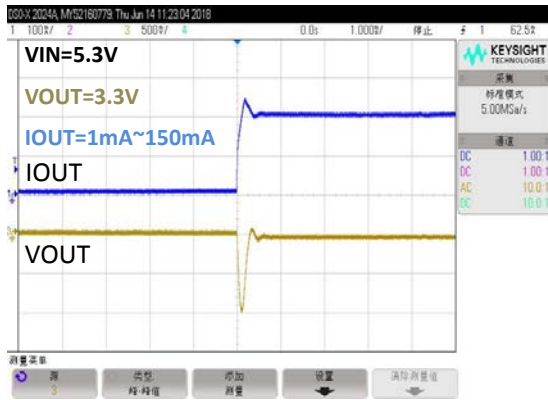

(5) MAX Output Current Vs. Input Voltage

TX7330MPR

Input Voltage	Max Output Current
6V	250mA
9V	200mA
12V	150mA
15V	100mA

TX7333MPR

Input Voltage	Max Output Current
6.3V	250mA
9V	200mA
12V	150mA
15V	100mA

TX7350MPR

Input Voltage	Max Output Current
8V	250mA
9V	200mA
12V	150mA
15V	100mA

Note: 1. The Max Output Current is the typical value;

2. In order to ensure that the best parameters can be achieved, the PCB is preferably provided with a large copper foil area to increase heat dissipation.



Package Outline Dimensions SOT-23

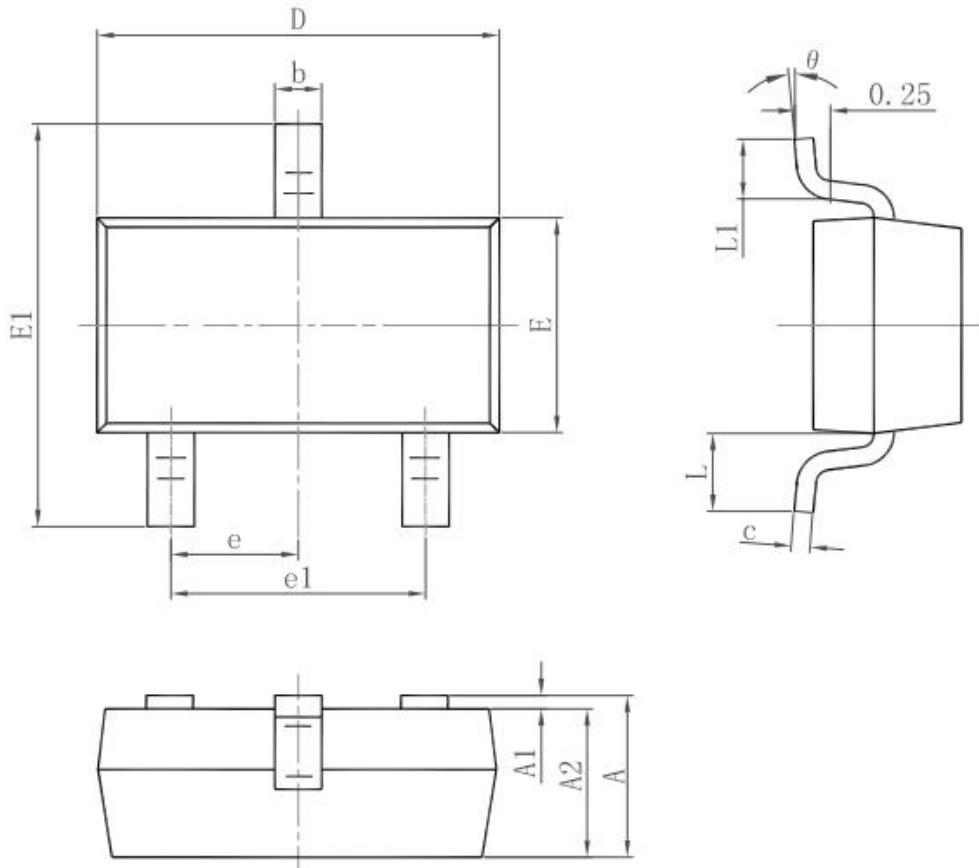

Symbol	Dimensions In Millimeters		Dimensions In Inches	
	Min.	Max.	Min.	Max.
A	0.900	1.150	0.035	0.045
A1	0.000	0.100	0.000	0.004
A2	0.900	1.050	0.035	0.041
b	0.300	0.500	0.012	0.020
c	0.080	0.150	0.003	0.006
D	2.800	3.000	0.110	0.118
E	1.200	1.400	0.047	0.055
E1	2.250	2.550	0.089	0.100
e	0.950 TYP.		0.037 TYP.	
e1	1.800	2.000	0.071	0.079
L	0.550 REF.		0.022 REF.	
L1	0.300	0.500	0.012	0.020
θ	0°	8°	0°	8°



Attention

- Any and all HUA XUAN YANG ELECTRONICS products described or contained herein do not have specifications that can handle applications that require extremely high levels of reliability, such as life-support systems, aircraft's control systems, or other applications whose failure can be reasonably expected to result in serious physical and/or material damage. Consult with your HUA XUAN YANG ELECTRONICS representative nearest you before using any HUA XUAN YANG ELECTRONICS products described or contained herein in such applications.
- HUA XUAN YANG ELECTRONICS assumes no responsibility for equipment failures that result from using products at values that exceed, even momentarily, rated values (such as maximum ratings, operating condition ranges, or other parameters) listed in products specifications of any and all HUA XUAN YANG ELECTRONICS products described or contained herein.
- Specifications of any and all HUA XUAN YANG ELECTRONICS products described or contained herein stipulate the performance, characteristics, and functions of the described products in the independent state, and are not guarantees of the performance, characteristics, and functions of the described products as mounted in the customer's products or equipment. To verify symptoms and states that cannot be evaluated in an independent device, the customer should always evaluate and test devices mounted in the customer's products or equipment.
- HUA XUAN YANG ELECTRONICS CO.,LTD. strives to supply high-quality high-reliability products. However, any and all semiconductor products fail with some probability. It is possible that these probabilistic failures could give rise to accidents or events that could endanger human lives, that could give rise to smoke or fire, or that could cause damage to other property. When designing equipment, adopt safety measures so that these kinds of accidents or events cannot occur. Such measures include but are not limited to protective circuits and error prevention circuits for safe design, redundant design, and structural design.
- In the event that any or all HUA XUAN YANG ELECTRONICS products(including technical data, services) described or contained herein are controlled under any of applicable local export control laws and regulations, such products must not be exported without obtaining the export license from the authorities concerned in accordance with the above law.
- No part of this publication may be reproduced or transmitted in any form or by any means, electronic or mechanical, including photocopying and recording, or any information storage or retrieval system, or otherwise, without the prior written permission of HUA XUAN YANG ELECTRONICS CO.,LTD.
- Information (including circuit diagrams and circuit parameters) herein is for example only ; it is not guaranteed for volume production. HUA XUAN YANG ELECTRONICS believes information herein is accurate and reliable, but no guarantees are made or implied regarding its use or any infringements of intellectual property rights or other rights of third parties.
- Any and all information described or contained herein are subject to change without notice due to product/technology improvement, etc. When designing equipment, refer to the "Delivery Specification" for the HUA XUAN YANG ELECTRONICS product that you intend to use.