



PRODUCT SPECIFICATION SHEET



Customer	-		
Customer P/N	-		
Product Type	Quartz Crystal Resonator		
Part Number	1SQ3270019	Version	S0
Part Description	SMD TUNING FORK 1.6 X 1.0		
Nominal Frequency	32.768000KHz		

Prepared	Li Xiang
Reviewed	Zhou Xueming
Approved	Liu Feng
Date	2025-11-12

Customer's Approval & Date :

广东惠伦晶体科技股份有限公司

中国广东省东莞市黄江镇东环路鸡啼岗段68号
 68 Donghuan Road, Jitigang Village, Huangjiang,
 Dongguan, Guangdong Province, P. R. China



WEB : <http://www.dgylec.com/>

TEL : +86 (0) 769 - 38879888

FAX : +86 (0) 769 - 38879889

EMAIL : yl@dgylec.com



Moisture Sensitivity Level 1

TABLE OF CONTENTS

#	Item	Page
1	History of Specification Revision	3
2	Electrical Specifications	4
	2.1 General specification	4
	2.2 Operation conditions	4
	2.3 Frequency stability & electrical parameters	4
3	Product Design	5
	3.1 Package dimensions and pad functions	5
	3.2 Land dimensions	5
	3.3 Recommended reflow profile and manual soldering conditions	6
4	Reliability	7~9
5	Marking and Packing	10
	5.1 Marking definition	11
	5.2 Taping	12
	5.3 Packing box	12
6	Environmental Substances	13

ATTENTION

- [1] If you intend to use products on the controlling equipment that relate to medical, aeronautical, aerospace, military science, space and etc., please make sure to let us know your intentions in advance.
- [2] Ultrasonic related process may cause damage to crystal blank by resonance itself. If ultrasonic related process is used, we strongly recommend to assess the damage risk under related ultrasonic conditions before use in production.

1. History of Specification Revision

Ver.	Contents	Date	Reviser	Remark
S0	Initial released	2025-11-12	Li Xiang	

FAITH LONG CRYSTAL

2. Electrical Specifications

2.1 General specification

#	Parameter	Value/Description	Unit	Remark
1	Nominal frequency	32.768000	kHz	-
2	Cutting type	X-cut	-	-
3	Oscillation mode	Fundamental	-	-
4	Moisture sensitivity level (MSL)	Level 1	-	IPC/JEDEC J-STD-033C
5	ESD	HBM \geq 2000V	-	JESD22-A114-B

2.2 Operation conditions

#	Parameter	Min.	Typ.	Max.	Unit	Remark
1	Operating temperature	-40	-	+85	°C	-
2	Storage temperature	-40	-	+85	°C	-
3	Load capacitance (C_L)	-	12.5	-	pF	-
4	Drive level	-	0.1	0.5	μ W	-

2.3 Frequency stability & electrical parameters

#	Parameter	Min.	Typ.	Max.	Unit	Remark
1	Initial frequency tolerance	-20	-	+20	ppm	At 25 \pm 3°C, DL=0.5uW
2	Turnover Temperature	20	25	30	°C	Measure this coefficient at 6 points of -40°C, -20°C, 25°C, 60°C, 85°C using S&A W2200
	Freq.vs Temp. Coefficient	-0.03 \pm 0.01			ppm/°C ²	
3	Equivalent series resistance (ESR)	-	-	90	k-ohms	-
4	Shunt capacitance (C0)	-	-	1.3	pF	-
5	insulation resistance	500	-	-	M-ohms	At DC 100V \pm 15V

Measure equipment: Electrical characteristics is measured by S&A 250B or equivalent.

Standard atmospheric conditions:

Unless otherwise specified, the standard environmental conditions for performance measurement and tests are under ambient temperature at +25 \pm 3°C and relative humidity: 60%.

3. Product Design

3.1 Package dimensions and pad functions (Unit : mm)

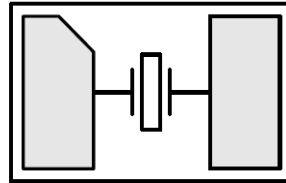
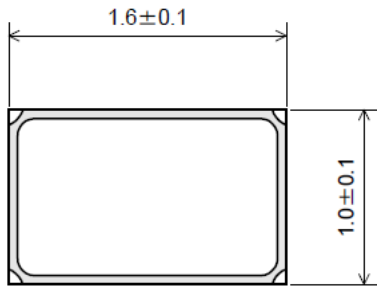

Internal connection

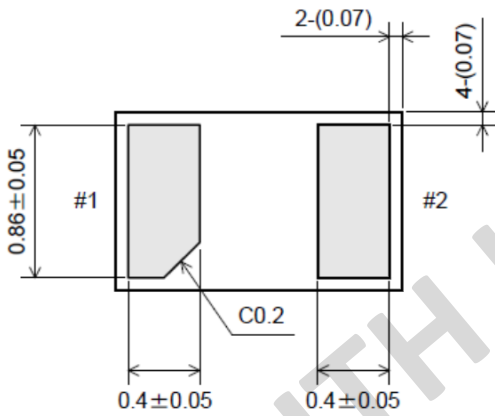
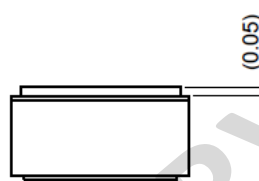
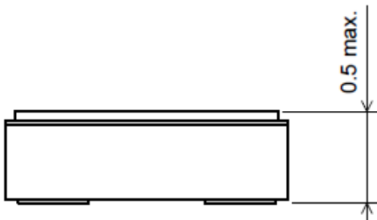

3.2 Land dimensions (Unit : mm)

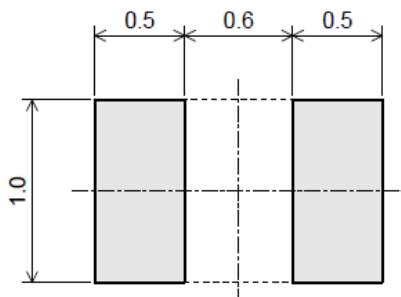

3. Product Design (Cont.)

3.3 Product storage conditions

- [1] Temperature: 15 to 35°C.
- [2] Humidity: 30 to 70% RH.
- [3] Time: within 18 months since manufacturing date.
- [4] Please store the products in a dry, clean, well-ventilated area and avoid direct sunlight exposure, heat, and vibration.

FAITH LONG CRYSTAL

4. Reliability

#	Test Item	Test Condition	Spec.
1	Bending test	<p>Apply pressure in the direction of the arrow at the rate of (about) 0.5mm/s until the deformation reaches 5mm, then hold for 30 seconds.</p>	A·B·D
2	Shear test	<p>Apply 20N static load to the core of quartz crystals in the direction of the arrow using a R0.5 scratch tool, then hold for 5 seconds.</p>	A·B·D
3	Core body strength	<p>Apply 5N static load to the quartz crystal units center in the direction of the arrow using a R0.5 pushing tool, then hold for 10 seconds.</p>	A·B·D
4	Vibration	<p>Frequency sweep method shall be applied as follows. Quartz crystal units shall be vibrated with the sweeping frequency from 10Hz to 55Hz and return to 10Hz in 1 minute, with 1.5mm amplitude. This vibration shall be applied for 2 hours in each 3 perpendicular axes. Other procedures conform to JISC60068-2-6.</p>	A·B·D

4. Reliability(Cont.)

#	Test Item	Test Condition	Spec.															
5	Shock	Quartz crystal units shall be accelerated at 9810m/s^2 by 1ms pulse duration. This shock shall be applied 3 times in each 3 perpendicular axes. Other procedures conform to JIS C 60068-2-27.	A·B·D															
6	Cold	Quartz crystal units shall be stored in the $-40\pm 3^\circ\text{C}$ atmosphere for 1000 hours Other procedures conform to JIS C 60068-2-1.	B·D·F															
7	Dry heat	Quartz crystal units shall be stored in the $100\pm 2^\circ\text{C}$ atmosphere for 100 hours. Other procedures conform to JIS C 60068-2-2.	C·D·F															
8	Damp heat	Quartz crystal units shall be stored in the $40\pm 2^\circ\text{C}$ atmosphere with 90 to 95% relative humidity for 1000 hours. Other procedures conform to JIS C 660068-2-3	B·D·F															
9	Change of temperature	<p>Quartz crystal units shall be subjected successively 100 cycles of tempera shown below. Other procedures conform to JIS C0025</p> <table border="1"> <thead> <tr> <th></th> <th>Temperature</th> <th>Duration</th> </tr> </thead> <tbody> <tr> <td>1</td> <td>$-40\pm 3^\circ\text{C}$</td> <td>30 minutes</td> </tr> <tr> <td>2</td> <td>Normal temperature</td> <td>Within 30 seconds</td> </tr> <tr> <td>3</td> <td>$100\pm 2^\circ\text{C}$</td> <td>30 minutes</td> </tr> <tr> <td>4</td> <td>Normal temperature</td> <td>Within 30 seconds</td> </tr> </tbody> </table>		Temperature	Duration	1	$-40\pm 3^\circ\text{C}$	30 minutes	2	Normal temperature	Within 30 seconds	3	$100\pm 2^\circ\text{C}$	30 minutes	4	Normal temperature	Within 30 seconds	B·D·F
	Temperature	Duration																
1	$-40\pm 3^\circ\text{C}$	30 minutes																
2	Normal temperature	Within 30 seconds																
3	$100\pm 2^\circ\text{C}$	30 minutes																
4	Normal temperature	Within 30 seconds																
10	Sealing	Quartz crystal units shall be soaked in 90°C or higher temperature hot water for 5 minutes.	G															
		Quartz crystal units shall be tested by Mass spectrometric leakage detector to measure the leakage rate of helium gas.	H															
11	Aging	Quartz crystal units shall be stored in the $85\pm 3^\circ\text{C}$ atmosphere for 720 ± 12 hours	C·D·F															
12	Solder-ability	<p>Terminals coated with flux shall be immersed in the solder bath for 3.5 ± 0.5 seconds.</p> <table border="1"> <thead> <tr> <th></th> <th>Items</th> <th>Conditions</th> </tr> </thead> <tbody> <tr> <td>1</td> <td>Solder</td> <td>Sn-3.0Ag-0.5Cu</td> </tr> <tr> <td>2</td> <td>Flux</td> <td>Approximately 25wt% methanol(JIS K 8891) solution of rosin(JIS K 5902).</td> </tr> <tr> <td>3</td> <td>Solder temperature</td> <td>$245\pm 5^\circ\text{C}$</td> </tr> </tbody> </table>		Items	Conditions	1	Solder	Sn-3.0Ag-0.5Cu	2	Flux	Approximately 25wt% methanol(JIS K 8891) solution of rosin(JIS K 5902).	3	Solder temperature	$245\pm 5^\circ\text{C}$	L			
	Items	Conditions																
1	Solder	Sn-3.0Ag-0.5Cu																
2	Flux	Approximately 25wt% methanol(JIS K 8891) solution of rosin(JIS K 5902).																
3	Solder temperature	$245\pm 5^\circ\text{C}$																

4. Reliability(Cont.)

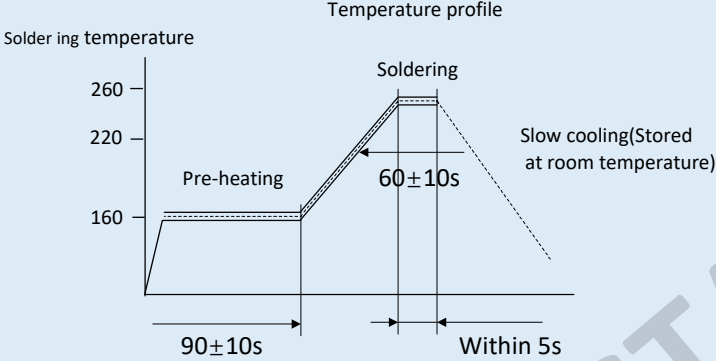
#	Test Item	Test Condition	Spec.
13	Resistance to soldering heat	Reflow soldering method  <p>Peak temperature: $260 \pm 5^\circ\text{C}$ for within 5 seconds. Soldering temperature: 220°C or higher for 60 ± 10 seconds. Pre-heating temperature: $160 \pm 10^\circ\text{C}$ for 90 ± 10 seconds. Quartz crystal units which is put on PCB shall be through reflow soldering furnace twice with the condition shown above.</p>	B·E·F·J
		Hot Air (HAKKO FR-802.A-1124B(ϕ 2.5)single) method Apply hot air for 7 ± 0.5 seconds, distance 10 ± 1 mm, $300 \pm 5^\circ\text{C}$, flow 10 ± 0.5 L/minutes	B·D·F·J
14	Resistance to solvents	Soak cleaning Quartz crystal units shall be soaked in isopropyl alcohol at normal temperature for 90 seconds.	A·B·D·J·K

Specifications

A	Without mechanical damage such as breaks and satisfy sealing specification
B	Frequency change: Within ± 5 ppm
C	Frequency change: Within ± 10 ppm
D	Equivalent series resistance(E.S.R.) change: Within ± 5 k Ω
E	Equivalent series resistance(E.S.R.) change: Within ± 10 k Ω
F	After conditioning, quartz crystal units shall be subjected to standard atmospheric conditions for 1 hour, and measured.
G	Without repetitive leaking bubbles from quartz crystal units.
H	1×10^{-9} Pa.m ³ /s or less
J	Without distinct deformation in appearance.
K	Marking shall be legible.
L	Minimum 95% of immersed terminal shall be covered with new uniform solder

5. Marking and Packing

5.1 Marking definition

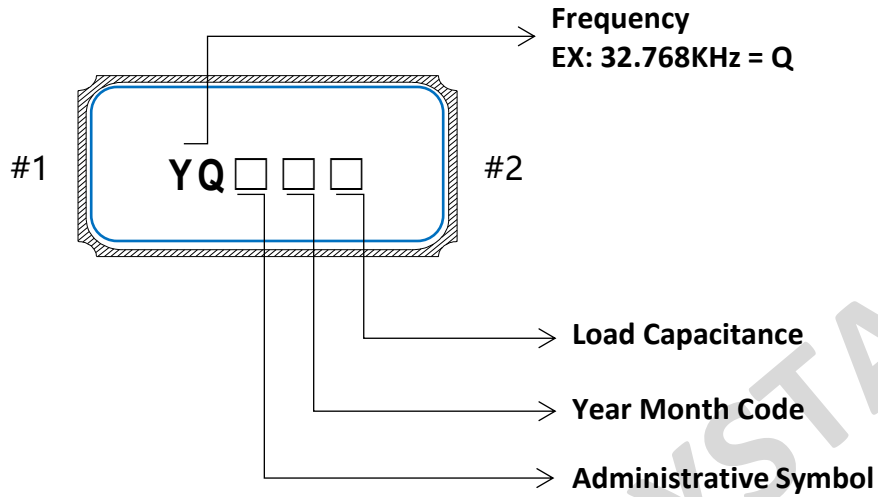

Table of Year and Month code

		Month											
Year		JAN	FEB	MAR	APR	MAY	JUN	JUL	AUG	SEP	OCT	NOV	DEC
2025	2029	A	B	C	D	E	F	G	H	J	K	L	M
2026	2030	N	P	Q	R	S	T	U	V	W	X	Y	Z
2027	2031	a	b	c	d	e	f	g	h	j	k	l	m
2028	2032	n	p	q	r	s	t	u	v	w	x	y	z

Load Capacitance

7.0pF	9.0pF	12.5pF	6pF
A	B	C	D

5. Marking and Packing (Cont.)

5.2 Taping

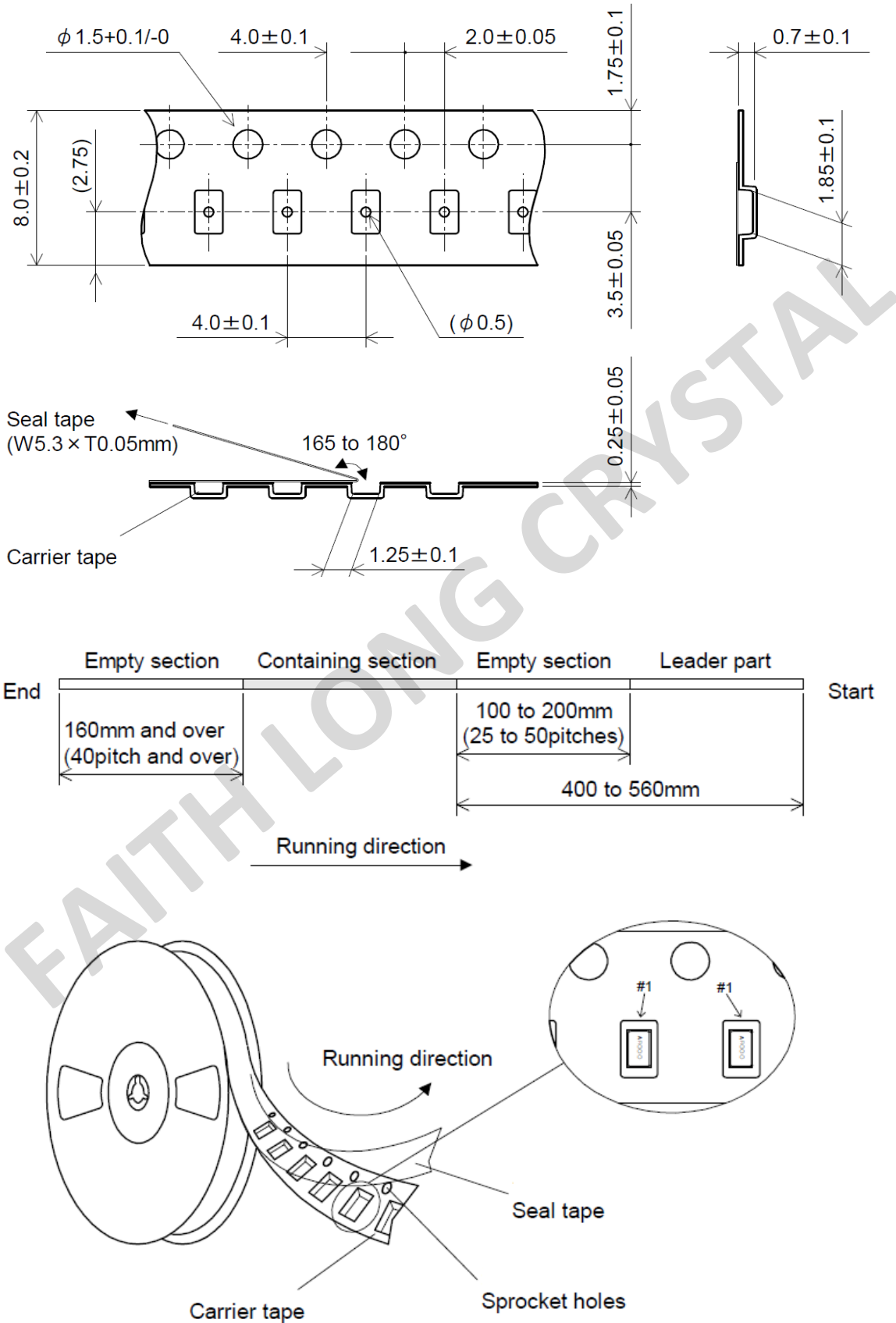

5. Marking and Packing (Cont.)

5.2 Taping (Cont.)

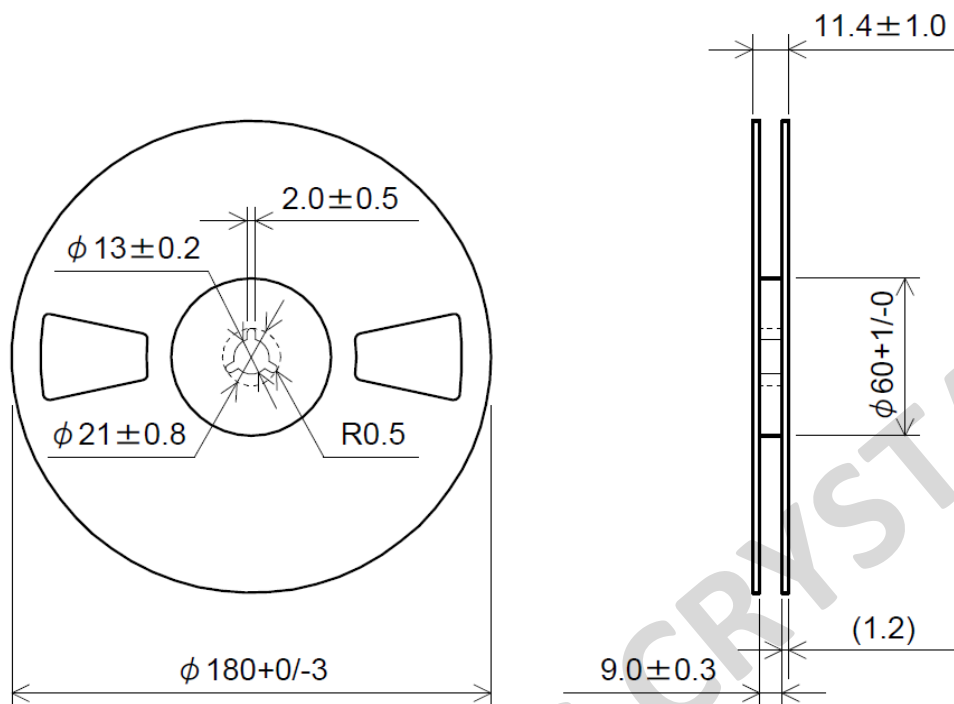

Material: Conductive Polystyrene

Quantity: 5000 pieces max./Reel

5.3 Packing box (Unit:mm)

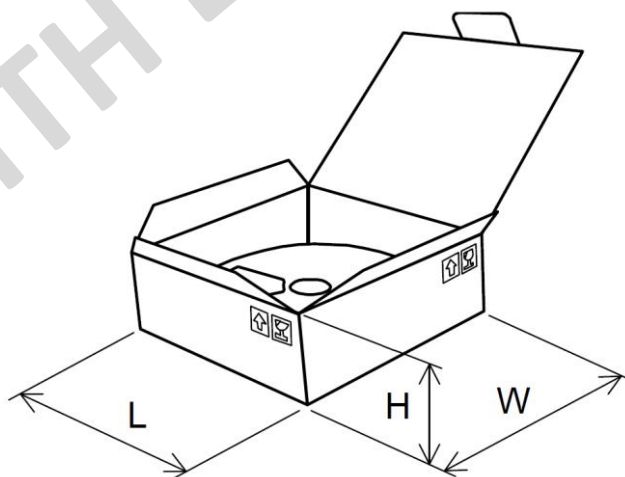

	L	W	H
Outer dimensions	188 (185)	188 (190)	70 (23)
Inner dimensions	185 (180)	183 (180)	60 (20)

6. Environmental substance

#	Banned substances	Max. concentration (ppm; mg/kg)	
		Products	Packing
1	Cadmium (Cd) and cadmium compounds 镉及镉化合物	100	100
2	Lead (Pb) and lead compounds 铅及铅化合物	1,000	100
3	Mercury (Hg) and mercury compounds 汞及汞化合物	1,000	100
4	Hexavalent-chromium VI (Cr+6) 六价铬化合物	1,000	100
5	Polybrominated biphenyls (PBBs) 聚溴联苯 PBB	1,000	N/A
6	Polybrominated diphenyl ethers (PBDEs) 聚溴二苯醚 PBDE	1,000	N/A
7	Di (2-ethylhexyl) phthalate (DEHP) 邻苯二甲酸二(2-乙基己基)酯 DEHP	1,000	N/A
8	Butyl benzyl phthalate (BBP) 邻苯二甲酸丁苄酯 BBP	1,000	N/A
9	Dibutyl phthalate (DBP) 邻苯二甲酸二丁酯 DBP	1,000	N/A
10	Diisobutyl Phthalate (DIBP) 邻苯二甲酸二异丁酯 DIBP	1,000	N/A
11	Fluorine (F), Chlorine (Cl), Bromine (Br), Iodine (I) 氟(F)、氯(Cl)、溴(Br)、碘(I)	900, 900, 900, 900 Note : Br + Cl < 1,000	N/A
12	Heavy metals (Hg, Cd, Pb, Cr+6, PBBs and PBDEs) in packing materials 包装材料中重金属(汞、镉、六价铬、铅、PBB、PBDE)之总量	N/A	100 铅(Pb) + 镉(Cd) + 汞(Hg) + 六价铬(Cr+6) < 100ppm
13	(SVHC) Substances of very high concern 高度关注物质	1,000	N/A