

MIGHTY MOUSE Cobra

TECHNICAL SPECIFICATIONS

805-061 triple-start with self-locking coupling nut, exploded view



How To Order Mighty Mouse Cobra Plug Connector and Backshell Assemblies							
Sample Part Number	801-069-26	ZNU	8-13	P	A	1	05
Connector Series and Mighty Mouse Cobra Basic Part Number	801-069-26 Double-Start self-locking plug with ratchet mechanism (the clicker) 804-066-06 QDC Push-Pull plug 805-061-16 Triple-Start plug with ratcheting anti-decoupling mechanism						
Material/Finish	M, MT, NF, ZNU, Z1 - See Table I						
Shell Size - Contact Arrangement	See Table V - A: 801-069 B: 804-066 C: 805-061						
Contact Style	A = Pin, solder B = Socket, solder P = Pin, Crimp S = Socket, crimp						
Polarization Key Position	A, B, C, D, E, F - See Table III						
Cable Exit Direction	1, 2, 3, 4, 5, 6, 7, 8 - See Table IV						
Cable Entry Size	See Table VI						

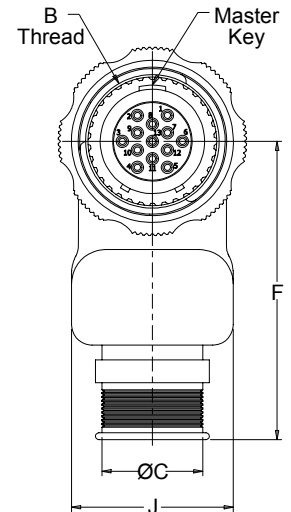

Specifications

- Current Rating: #23 5 Amps
- Test Voltage (DWV) #23: 500 VAC Sea Level
- Insulation Resistance: 5000 megohms minimum
- Contact Resistance: 73 millivolt drop at 5 Amp test current
- Mating Cycles Series 801 and 804: 2000; Series 805: 500
- Operating Temperature: -55° C. to +150° C.
- Shielding Effectiveness: 50 dB min from 100MHz to 1000MHz.
- Magnetic Permeability: 2.0μ
- Vibration: 37g / Shock: 300g
- Immersion, mated: 1 meter water immersion for 1 hour

Materials/finish

- Contacts: Copper alloy, gold plated
- Backshell Housing and Lid: Aluminum or Stainless Steel
- Backshell Sealing Gasket and Interfacial Seal: Fluorosilicone
- Screws: 300 Series Stainless Steel
- Insulator: LCP

Notes

- Rear insulator grommet not supplied.
- Cobra plug connectors mate with respective series receptacles with same polarization and opposite contact gender.
- Hand crimp tool: P/N 809-015. Positioner for hand tool: P/N 809-005. Insertion/extraction tool P/N 809-088.
- Crimp barrel accommodates 22, 24, 26 and 28 gage wire.
- All Cobra plugs equipped with Size #23 contacts.

Table I: Shell Material/Finish		
Symbol	Material	Finish
M	Aluminum Alloy	Electroless Nickel (RoHS)
NF		Cad/O.D. over Electroless Nickel
MT		Nickel-PTFE (RoHS)
ZNU		Black Zinc Nickel over Electroless Nickel (RoHS)
Z1	Stainless Steel	Passivate

Table III: Key Positions		
	A°	B°
A	150°	210°
B	75°	210°
C	95°	230°
D	140°	275°
E	75°	275°
F	95°	210°

Table IV: Exit Direction	
Direction	C°
1	0°
2	45°
3	90°
4	135°
5	180°
6	225°
7	270°
8	315°

Direction 2 Shown

Table VI - Cable Entry	
Code	Entry Size
02	.125
03	.188
04	.250
05	.313
06	.375
07	.438
08	.500
09	.563
10	.625
11	.688
12	.750
13*	.813
14*	.875
15*	.938
16*	1.000
17*	1.063

* Entry codes 13-17 not available for Series 804 Cobra

Table V - Shell Size/Contact Arrangements								
A: 801-069			B: 804-066			C: 805-061		
Shell Size	Contact Arrangement	Max Entry	Shell Size	Contact Arrangement	Max Entry	Shell Size	Contact Arrangement	Max Entry
5	5-3	03	5	5-3	03	8	8-4, 8-6, 8-7	04
6	6-4, 6-6, 6-7	04	6	6-4, 6-6, 6-7	04	9	9-10	05
7	7-10	05	7	7-10	05	10	10-13	06
8	8-13	06	8	8-13	06	11	11-19	07
9	9-19	07	9	9-19	07	12	12-26	08
10	10-26	08	10	10-26	08	13	13-31	09
11	11-31	09	12	12-37	10	15	15-37	10
13	13-37	10	14	14-55	12	18	18-55	12
16	16-55	12				19	19-85	13
17	17-85	13				21	21-100	15
19	19-100	15				23	23-130	17
21	21-130	17						

THIS COPYRIGHTED DOCUMENT IS THE PROPERTY OF GLENNAIR, INC. AND IS FURNISHED ON THE CONDITION THAT IT IS NOT TO BE DISCLOSED, REPRODUCED IN WHOLE OR IN PART, OR USED TO SOLICIT QUOTATIONS FROM COMPETITIVE SOURCES, OR USED FOR MANUFACTURE BY ANYONE OTHER THAN GLENNAIR, INC. WITHOUT WRITTEN PERMISSION FROM GLENNAIR, INC. THE INFORMATION HEREIN HAS BEEN DEVELOPED AT GLENNAIR'S EXPENSE AND MAY BE USED FOR ENGINEERING EVALUATION AND INCORPORATION INTO TECHNICAL SPECIFICATIONS AND OTHER DOCUMENTS WHICH SPECIFY PROCUREMENT OF PRODUCTS FROM GLENNAIR, INC.

REVISION HISTORY			
REV	DESCRIPTION	DATE	APPROVED
A	PRODUCTION RELEASE	10/09/12	EAG
B	REVISED PER DCN #45302	02/12/13	EAG

TABLE I - MATERIAL / FINISH CLASS		
CLASS	SHELL MATERIAL	FINISH
M	ALUMINUM ALLOY	ELECTROLESS NICKEL (RoHS)
MT	ALUMINUM ALLOY	NICKEL-PTFE (RoHS)
NF	ALUMINUM ALLOY	OLIVE DRAB CADMIUM OVER ELECTROLESS NICKEL
ZNU	ALUMINUM ALLOY	BLACK ZINC-NICKEL OVER ELECTROLESS NICKEL (RoHS)
Z1	STAINLESS STEEL	PASSIVATE (RoHS)

CONTACT GLENNAIR FOR ADDITIONAL FINISHES

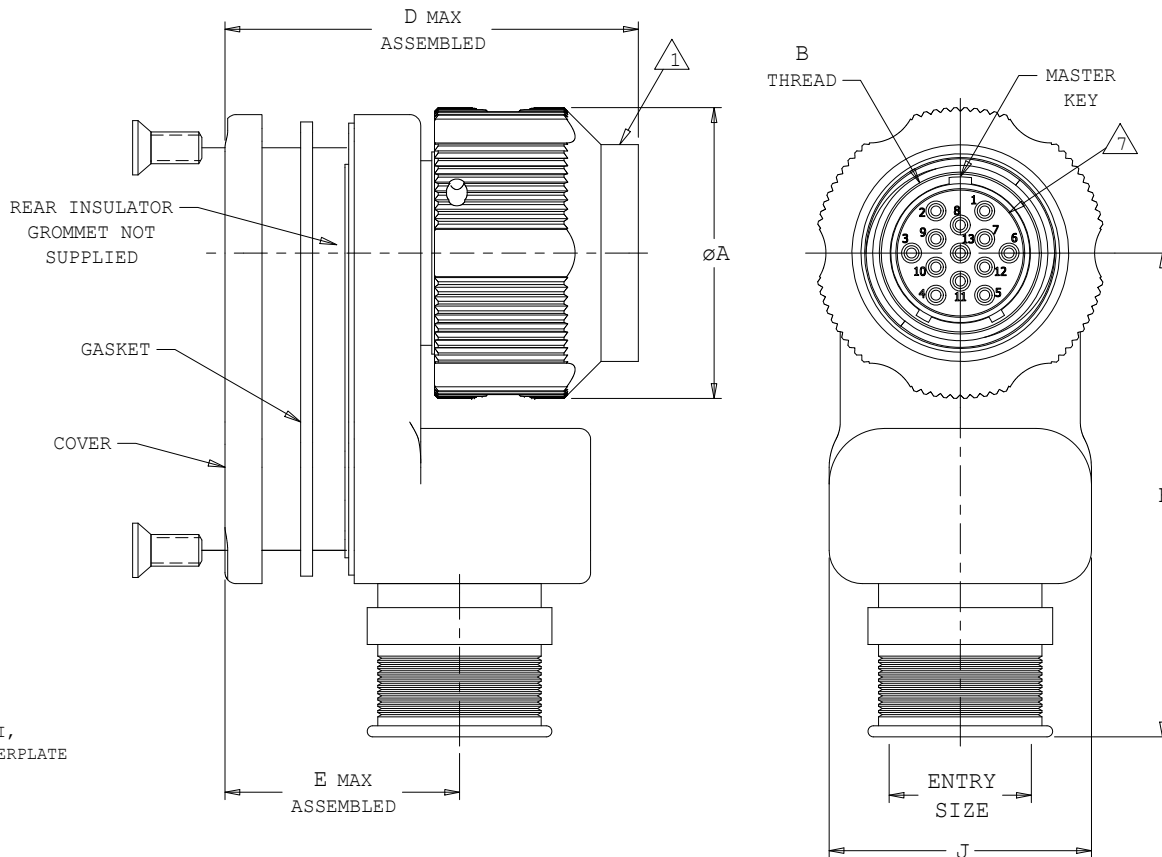

FACE VIEW OF PLUG AS VIEWED FROM ENGAGING END (8-13PA1 SHOWN)

NOTES: UNLESS OTHERWISE SPECIFIED

1. ASSEMBLY TO BE IDENTIFIED WITH GLENNAIR'S NAME, PART NUMBER, AND DATE CODE, SPACE PERMITTING.

2. MATERIAL / FINISH:
 PLUG BARREL, COUPLING NUT, HOUSING, COVER - ALUMINUM ALLOY OR STAINLESS STEEL / SEE TABLE I
 INSULATOR - LCP / NONE
 INTERFACIAL SEAL, GASKET - FLUOROSILICONE / NONE
 CONTACT - COPPER ALLOY / GOLD PLATE PER ASTM B 488, TYPE II, CODE C, CLASS 1.25 (.00005 MIN THK), OVER A SUITABLE UNDERPLATE
 CONTACT RETENTION CLIP - BERYLLIUM COPPER ALLOY / NONE
 HARDWARE - STAINLESS STEEL / PASSIVATE OR BLACK OXIDE
 RETAINING WIRE - TORLON / NONE
 DETENT SPRING / RIVET - STAINLESS STEEL / PASSIVATE

3. CONTACTS ARE SIZE 23.

4. CONSULT FACTORY FOR ADDITIONAL CONTACT ARRANGEMENTS AND/OR SHELL ORIENTATIONS.

5. CRIMP BARREL ACCOMMODATES 22, 24, 26, AND 28 GAGE WIRE.

6. CRIMP TOOL DATA:
 A. HAND CRIMP TOOL: GLENNAIR PART NO. 809-015.
 B. POSITIONER FOR HAND TOOL: GLENNAIR PART NO. 809-005.
 C. INSERTION/EXTRACTION TOOL: GLENNAIR PART NO. 809-088.

7. CONTACT ARRANGEMENT, CONTACT GENDER, KEY POSITIONS, AND SHELL ORIENTATION SHOWN ARE FOR REFERENCE ONLY.

8. THIS CONNECTOR MATES WITH ALL QUICK COUPLING, HIGH DENSITY RECEPTACLE CONNECTORS WITH SAME POLARIZATION AND OPPOSITE CONTACT GENDER (801-003 THROUGH 801-006 AND 801-009 THROUGH 801-012).

9. REAR INSULATOR GROMMET NOT SUPPLIED.

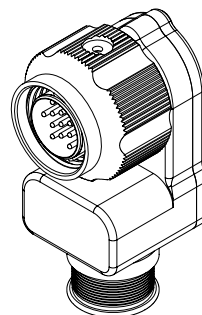

UNLESS OTHERWISE SPECIFIED	DRAWN	EAG	03/05/12	GLENNAIR, INC. 1211 AIR WAY - GLENDALE - CALIFORNIA 91201						
DIMENSIONS ARE IN INCHES	CHECK	GSB	03/05/12							
TOLERANCES	ENGR	EAG	03/05/12	TITLE PLUG CONNECTOR, SERIES 801, RATCHETING, COBRA STYLE						
FRACTIONS ± 1/16	<i>D. Brown</i> APPROVED			CODE IDENT. NO.	SIZE	DRAWING NO.	REV.			
DECIMALS .XX ± .03				06324	A	801-069	B			
ANGLES ± 2°				DO NOT SCALE THIS DRAWING	RELEASE DATE	03/05/12	SCALE	N.A.	WEIGHT	N.A.
DO NOT SCALE THIS DRAWING	B/F	10C5078	P/C	80	ORIGINAL RELEASE DATE	03/05/12				

THIS COPYRIGHTED DOCUMENT IS THE PROPERTY OF GLENAIR, INC. AND IS FURNISHED ON THE CONDITION THAT IT IS NOT TO BE DISCLOSED, REPRODUCED IN WHOLE OR IN PART, OR USED TO SOLICIT QUOTATIONS FROM COMPETITIVE SOURCES, OR USED FOR MANUFACTURE BY ANYONE OTHER THAN GLENAIR, INC. WITHOUT WRITTEN PERMISSION FROM GLENAIR, INC. THE INFORMATION HEREIN HAS BEEN DEVELOPED AT GLENAIR'S EXPENSE AND MAY BE USED FOR ENGINEERING EVALUATION AND INCORPORATION INTO TECHNICAL SPECIFICATIONS AND OTHER DOCUMENTS WHICH SPECIFY PROCUREMENT OF PRODUCTS FROM GLENAIR, INC.

REVISION HISTORY
SEE SHEET 1 OF 2

TABLE II - DIMENSIONAL DATA

SHELL SIZE	øA	B THREAD	D	E	F	G	H	J	MAX ENTRY
5	.65 [16.5]	.3125-.05P-.1L-2B	.84 [21.3]	.32 [8.1]	1.21 [30.7]	1.40 [35.6]	1.23 [31.2]	.500 [12.70]	03
6	.65 [16.5]	.3750-.05P-.1L-2B	.86 [21.8]	.34 [8.6]	1.24 [31.5]	1.42 [36.1]	1.25 [31.8]	.560 [14.22]	04
7	.69 [17.5]	.4375-.05P-.1L-2B	.88 [22.4]	.39 [9.9]	1.28 [32.5]	1.44 [36.6]	1.27 [32.3]	.650 [16.51]	05
8	.79 [20.1]	.5000-.05P-.1L-2B	.89 [22.6]	.42 [10.7]	1.31 [33.3]	1.45 [36.8]	1.28 [32.5]	.710 [18.03]	06
9	.83 [21.1]	.5625-.05P-.1L-2B	.92 [23.4]	.45 [11.4]	1.34 [34.0]	1.48 [37.6]	1.31 [33.3]	.770 [19.56]	07
10	.92 [23.4]	.6250-.05P-.1L-2B	.96 [24.4]	.48 [12.2]	1.37 [34.8]	1.52 [38.6]	1.35 [34.3]	.835 [21.21]	08
11	T.B.D.	.6875-.05P-.1L-2B	T.B.D.	T.B.D.	T.B.D.	T.B.D.	T.B.D.	T.B.D.	09
13	1.10 [27.9]	.8125-.1P-.2L-2B	1.13 [28.7]	.52 [13.2]	1.48 [37.6]	1.80 [45.7]	1.63 [41.4]	.950 [24.13]	10
16	1.34 [34.0]	1.0000-.1P-.2L-2B	T.B.D.	T.B.D.	T.B.D.	T.B.D.	T.B.D.	T.B.D.	12
17	1.45 [36.8]	1.0625-.1P-.2L-2B	1.28 [32.5]	.63 [16.0]	1.78 [45.2]	1.92 [48.8]	1.78 [45.2]	1.180 [29.97]	13
19	1.50 [38.1]	1.1875-.1P-.2L-2B	T.B.D.	T.B.D.	T.B.D.	T.B.D.	T.B.D.	T.B.D.	15
21	1.65 [41.9]	1.3125-.1P-.2L-2B	T.B.D.	T.B.D.	T.B.D.	T.B.D.	T.B.D.	T.B.D.	17

TABLE VI-CABLE ENTRY	
CODE	ENTRY SIZE
02	.125
03	.188
04	.250
05	.313
06	.375
07	.438
08	.500
09	.563
10	.625
11	.688
12	.750
13	.813
14	.875
15	.938
16	1.000
17	1.063

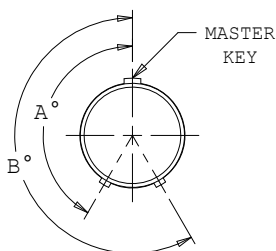
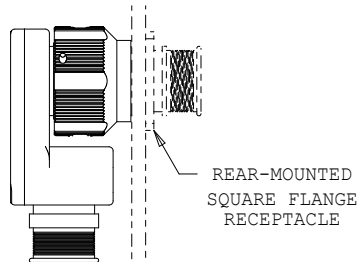

TABLE III - KEY POSITION		
POSITION	A°	B°
A (NORMAL)	150°	210°
B	75°	210°
C	95°	230°
D	140°	275°
E	75°	275°
F	95°	210°

KEY POSITION
(POSITION A SHOWN)



SHOWN INSTALLED

TABLE IV-EXIT DIRECTION	
DIRECTION	C°
1	0°
2	45°
3	90°
4	135°
5	180°
6	225°
7	270°
8	315°

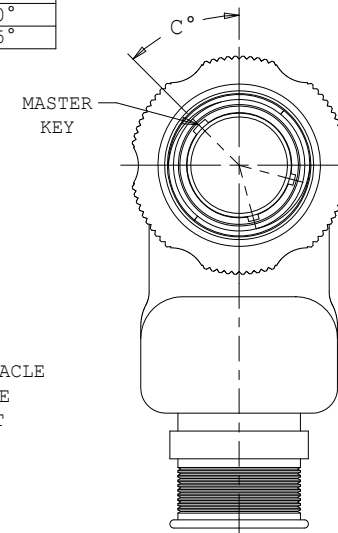

CABLE EXIT DIRECTION
(DIRECTION 2 SHOWN)

PART NUMBER DEVELOPMENT

EXAMPLE: 801-069 -26 ZNU 8-13 P A 1 05

CONNECTOR SERIES

SHELL STYLE

-26 = SELF-LOCKING PLUG WITH RATCHET MECHANISM (THE "CLICKER")

CLASS (SEE TABLE I)

SHELL SIZE - CONTACT ARRANGEMENT
(SEE TABLE V)

CONTACT STYLE

- A = PIN, SOLDER
- B = SOCKET, SOLDER
- P = PIN, CRIMP
- S = SOCKET, CRIMP

KEY POSITION

A THROUGH F (SEE TABLE III)

CABLE EXIT DIRECTION

1 THROUGH 8 (SEE TABLE IV)

CABLE ENTRY SIZE (SEE TABLE VI)

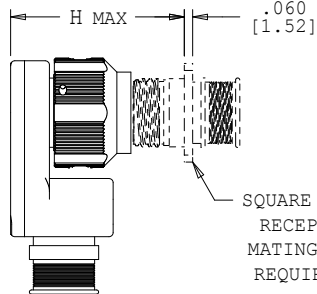

SQUARE FLANGE RECEPTACLE MATING SPACE REQUIREMENT

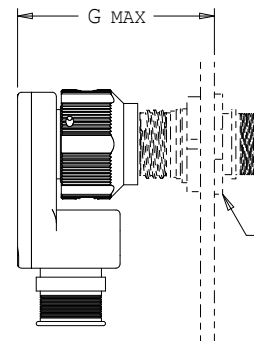

JAM NUT RECEPTACLE MATING SPACE REQUIREMENT

TABLE V - AVAILABLE ARRANGEMENTS	
SHELL SIZE	CONTACT ARRANGEMENT*
5	5-3
6	6-4, 6-6, 6-7
7	7-10
8	8-13
9	9-19
10	10-26
11	11-31
13	13-37
16	16-55
17	17-85
19	19-100
21	21-130

*: # FOLLOWING DASH = # OF CONTACTS

UNLESS OTHERWISE SPECIFIED		DRAWN	EAG	03/05/12	GLENAIR, INC. 1211 AIR WAY - GLENDALE - CALIFORNIA 91201 TITLE PLUG CONNECTOR, SERIES 801, RATCHETING, COBRA STYLE			
DIMENSIONS ARE IN INCHES		CHECK	GSB	03/05/12				
TOLERANCES		ENGR	EAG	03/05/12	CODE IDENT. NO. 06324 SIZE A DRAWING NO. 801-069 REV. B			
FRACTIONS ± 1/16		APPROVED			DO NOT SCALE THIS DRAWING RELEASE DATE 03/05/12 SCALE N.A. WEIGHT N.A. SHEET 2 OF 2			
DECIMALS .XX ± .03					ORIGINAL RELEASE DATE 03/05/12			
ANGLES ± 2°								

THIS COPYRIGHTED DOCUMENT IS THE PROPERTY OF GLENNAIR, INC. AND IS FURNISHED ON THE CONDITION THAT IT IS NOT TO BE DISCLOSED, REPRODUCED IN WHOLE OR IN PART, OR USED TO SOLICIT QUOTATIONS FROM COMPETITIVE SOURCES, OR USED FOR MANUFACTURE BY ANYONE OTHER THAN GLENNAIR, INC. WITHOUT WRITTEN PERMISSION FROM GLENNAIR, INC. THE INFORMATION HEREIN HAS BEEN DEVELOPED AT GLENNAIR'S EXPENSE AND MAY BE USED FOR ENGINEERING EVALUATION AND INCORPORATION INTO TECHNICAL SPECIFICATIONS AND OTHER DOCUMENTS WHICH SPECIFY PROCUREMENT OF PRODUCTS FROM GLENNAIR, INC.

REVISION HISTORY			
REV	DESCRIPTION	DATE	APPROVED
A	PRODUCTION RELEASE	01/18/13	EAG
B	REVISED PER DCN #45302	02/12/13	EAG

TABLE I - MATERIAL / FINISH CLASS		
CLASS	SHELL MATERIAL	FINISH
M	ALUMINUM ALLOY	ELECTROLESS NICKEL (RoHS)
MT	ALUMINUM ALLOY	NICKEL-PTFE (RoHS)
NF	ALUMINUM ALLOY	OLIVE DRAB CADMIUM OVER ELECTROLESS NICKEL
ZNU	ALUMINUM ALLOY	BLACK ZINC-NICKEL OVER ELECTROLESS NICKEL (RoHS)
Z1	STAINLESS STEEL	PASSIVATE (RoHS)

CONTACT GLENNAIR FOR ADDITIONAL FINISHES

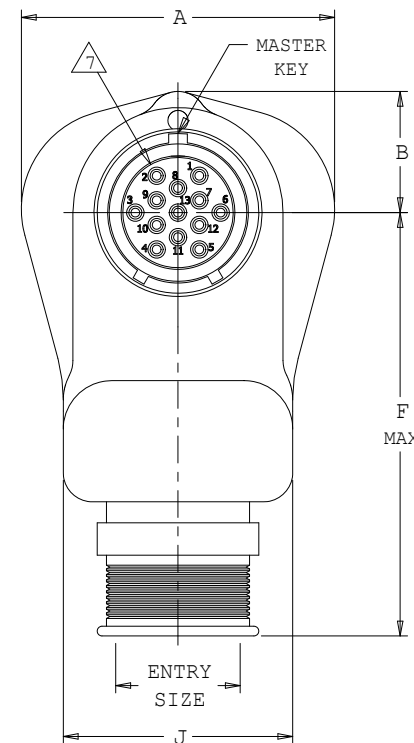
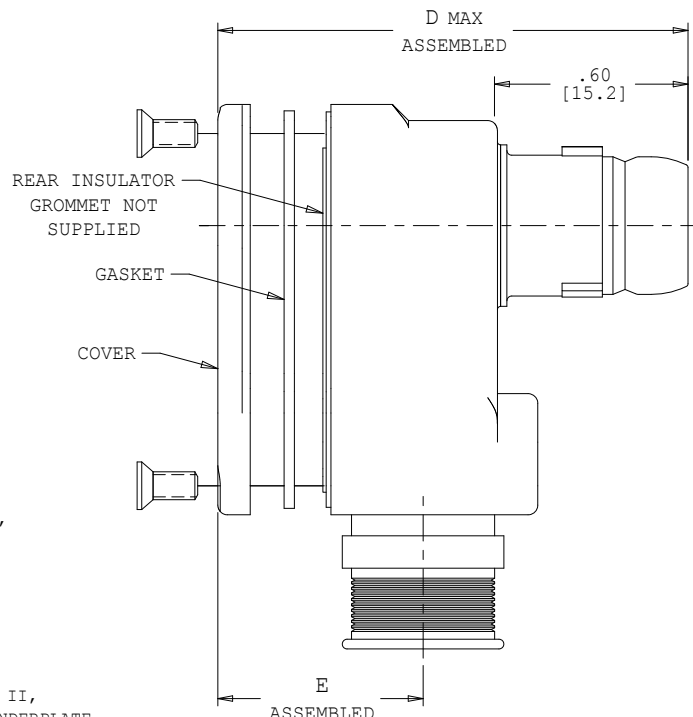

FACE VIEW OF PLUG AS VIEWED FROM ENGAGING END (8-13PA1 SHOWN)

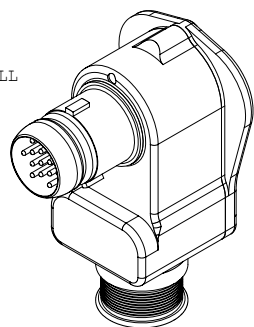

NOTES: UNLESS OTHERWISE SPECIFIED

1. ASSEMBLY TO BE IDENTIFIED WITH GLENNAIR'S NAME, PART NUMBER, AND DATE CODE, SPACE PERMITTING.

2. MATERIAL / FINISH:
 PLUG BARREL, HOUSING, COVER - ALUMINUM ALLOY OR STAINLESS STEEL / SEE TABLE I
 INSULATOR - LCP / NONE
 INTERFACIAL SEAL, GASKET - FLUOROSILICONE / NONE
 CONTACT - COPPER ALLOY / GOLD PLATE PER ASTM B 488, TYPE II, CODE C, CLASS 1.25 (.00005 MIN THK), OVER A SUITABLE UNDERPLATE
 CONTACT RETENTION CLIP - BERYLLIUM COPPER ALLOY / NONE
 HARDWARE - STAINLESS STEEL / PASSIVATE OR BLACK OXIDE

3. CONTACTS ARE SIZE 23.

4. CONSULT FACTORY FOR ADDITIONAL CONTACT ARRANGEMENTS AND/OR SHELL ORIENTATIONS.

5. CRIMP BARREL ACCOMMODATES 22, 24, 26, AND 28 GAGE WIRE.

6. CRIMP TOOL DATA:
 A. HAND CRIMP TOOL: GLENNAIR PART NO. 809-015.
 B. POSITIONER FOR HAND TOOL: GLENNAIR PART NO. 809-005.
 C. INSERTION/EXTRACTION TOOL: GLENNAIR PART NO. 809-088.

7. CONTACT ARRANGEMENT, CONTACT GENDER, KEY POSITIONS, AND SHELL ORIENTATION SHOWN ARE FOR REFERENCE ONLY.

8. THIS CONNECTOR MATES WITH ALL QUICK-DISCONNECT, HIGH DENSITY RECEPTACLE CONNECTORS WITH SAME POLARIZATION AND OPPOSITE CONTACT GENDER (804-003 THROUGH 804-006, 804-009, 804-020, AND 804-021).

9. REAR INSULATOR GROMMET NOT SUPPLIED.

UNLESS OTHERWISE SPECIFIED		DRAWN	EAG	01/18/13	GLENNAIR, INC. 1211 AIR WAY - GLENDALE - CALIFORNIA 91201 TITLE PLUG CONNECTOR, SERIES 804, COBRA STYLE			
DIMENSIONS ARE IN INCHES		CHECK	JMT	01/18/13				
TOLERANCES		ENGR	EAG	01/18/13				
FRACTIONS ± 1/16		 APPROVED			CODE IDENT. NO.	SIZE	DRAWING NO.	REV.
DECIMALS .XX ± .03					06324	A	804-066	B
.XXX ± .015					SCALE N.A. WEIGHT N.A. SHEET 1 OF 2			
ANGLES ± 2°		DO NOT SCALE THIS DRAWING		RELEASE DATE	01/18/13			
		B/F 12C3202 P/C 80		ORIGINAL RELEASE DATE	01/18/13			

THIS COPYRIGHTED DOCUMENT IS THE PROPERTY OF GLENAIR, INC. AND IS FURNISHED ON THE CONDITION THAT IT IS NOT TO BE DISCLOSED, REPRODUCED IN WHOLE OR IN PART, OR USED TO SOLICIT QUOTATIONS FROM COMPETITIVE SOURCES, OR USED FOR MANUFACTURE BY ANYONE OTHER THAN GLENAIR, INC. WITHOUT WRITTEN PERMISSION FROM GLENAIR, INC. THE INFORMATION HEREIN HAS BEEN DEVELOPED AT GLENAIR'S EXPENSE AND MAY BE USED FOR ENGINEERING EVALUATION AND INCORPORATION INTO TECHNICAL SPECIFICATIONS AND OTHER DOCUMENTS WHICH SPECIFY PROCUREMENT OF PRODUCTS FROM GLENAIR, INC.

REVISION HISTORY

SEE SHEET 1 OF 2

TABLE II - DIMENSIONAL DATA

SHELL SIZE	øA	B	D	E	F	G	H	J	MAX ENTRY
5	.67 [17.0]	.27 [6.9]	1.03 [26.2]	.29 [7.4]	1.24 [31.5]	1.31 [33.4]	1.16 [29.5]	.500 [12.7]	03
6	.75 [19.1]	.30 [7.6]	1.08 [27.4]	.31 [7.9]	1.27 [32.3]	1.36 [34.5]	1.21 [30.7]	.560 [14.2]	04
7	.88 [22.4]	.34 [8.6]	1.20 [30.5]	.36 [9.1]	1.31 [33.3]	1.47 [37.3]	1.32 [33.5]	.650 [16.5]	05
8	.97 [24.6]	.38 [9.7]	1.24 [31.5]	.39 [9.9]	1.34 [34.0]	1.51 [38.4]	1.36 [34.5]	.710 [18.0]	06
9	1.06 [26.9]	.41 [10.4]	1.30 [33.0]	.42 [10.7]	1.37 [34.8]	1.58 [40.1]	1.43 [36.3]	.770 [19.6]	07
10	1.15 [29.2]	.44 [11.2]	1.35 [34.3]	.45 [11.4]	1.40 [35.6]	1.62 [41.1]	1.47 [37.3]	.835 [21.2]	08
12	1.33 [33.8]	.50 [12.7]	1.44 [36.6]	.49 [12.4]	1.51 [38.4]	1.71 [43.4]	1.56 [39.6]	.950 [24.1]	10
14	T.B.D.	T.B.D.	T.B.D.	T.B.D.	T.B.D.	T.B.D.	T.B.D.	T.B.D.	12

TABLE VI - CABLE ENTRY

CODE	ENTRY SIZE
02	.125
03	.188
04	.250
05	.313
06	.375
07	.438
08	.500
09	.563
10	.625
11	.688
12	.750

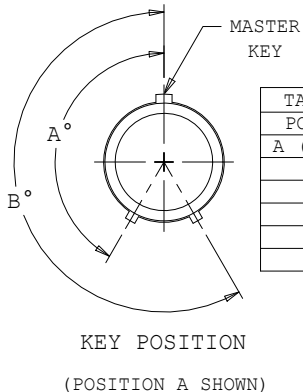

TABLE III - KEY POSITION

POSITION	A°	B°
A (NORMAL)	150°	210°
B	75°	210°
C	95°	230°
D	140°	275°
E	75°	275°
F	95°	210°

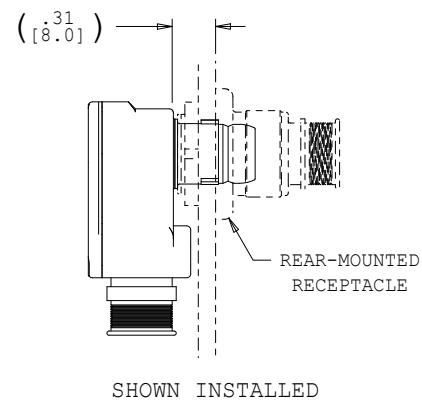
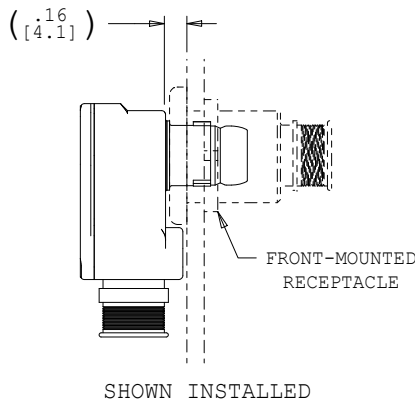
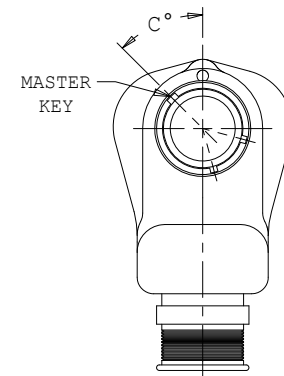
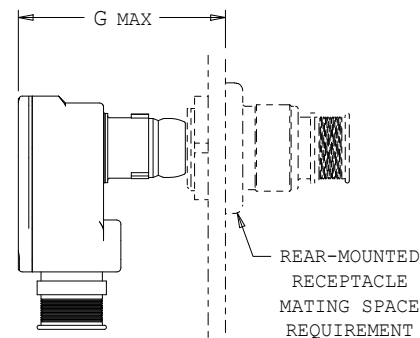
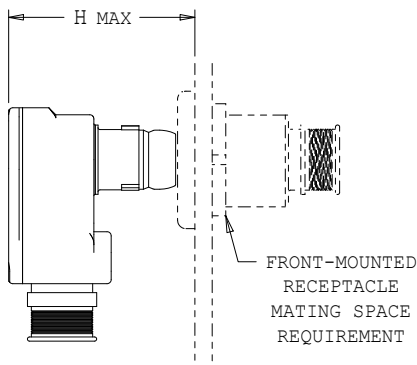
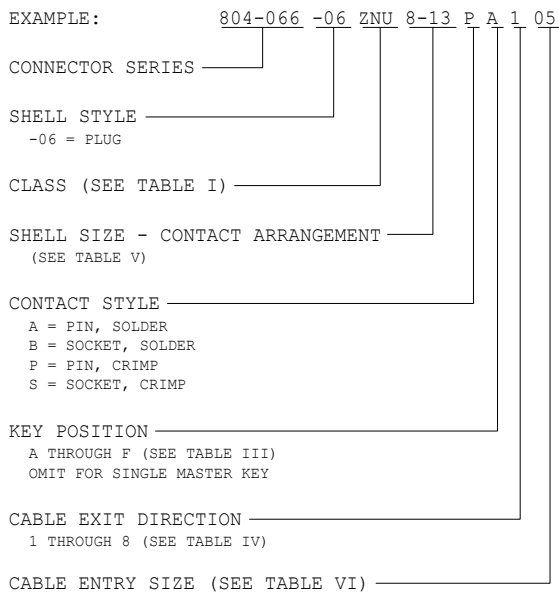

TABLE IV - EXIT DIRECTION

DIRECTION	C°
1	0°
2	45°
3	90°
4	135°
5	180°
6	225°
7	270°
8	315°

PART NUMBER DEVELOPMENT



CABLE EXIT DIRECTION (DIRECTION 2 SHOWN)

TABLE V - AVAILABLE ARRANGEMENTS

SHELL SIZE	CONTACT ARRANGEMENT*
5	5-3
6	6-4, 6-6, 6-7
7	7-10
8	8-13
9	9-19
10	10-26
12	12-37
14	14-55

*: # FOLLOWING DASH = # OF CONTACTS

UNLESS OTHERWISE SPECIFIED DIMENSIONS ARE IN INCHES TOLERANCES FRACTIONS ± 1/16 DECIMALS .XX ± .03 .XXX ± .015 ANGLES ± 2°	DRAWN	EAG	01/18/13	<p>GLENAIR, INC. 1211 AIR WAY - GLENDALE - CALIFORNIA 91201</p> <p>TITLE PLUG CONNECTOR, SERIES 804, COBRA STYLE</p>
	CHECK	JMT	01/18/13	
	ENGR	EAG	01/18/13	
DO NOT SCALE THIS DRAWING	RELEASE DATE	01/18/13	06324	<p>CODE IDENT. NO. SIZE DRAWING NO. REV.</p> <p>A 804-066 B</p>
B/F 12C3202 P/C 80	RELEASE DATE	01/18/13	SCALE N.A.	WEIGHT N.A. SHEET 2 OF 2

THIS COPYRIGHTED DOCUMENT IS THE PROPERTY OF GLENNAIR, INC. AND IS FURNISHED ON THE CONDITION THAT IT IS NOT TO BE DISCLOSED, REPRODUCED IN WHOLE OR IN PART, OR USED TO SOLICIT QUOTATIONS FROM COMPETITIVE SOURCES, OR USED FOR MANUFACTURE BY ANYONE OTHER THAN GLENNAIR, INC. WITHOUT WRITTEN PERMISSION FROM GLENNAIR, INC. THE INFORMATION HEREIN HAS BEEN DEVELOPED AT GLENNAIR'S EXPENSE AND MAY BE USED FOR ENGINEERING EVALUATION AND INCORPORATION INTO TECHNICAL SPECIFICATIONS AND OTHER DOCUMENTS WHICH SPECIFY PROCUREMENT OF PRODUCTS FROM GLENNAIR, INC.

REVISION HISTORY			
REV	DESCRIPTION	DATE	APPROVED
A	PRODUCTION RELEASE	07/19/12	EAG
B	REVISED PER DCN #45302	02/12/13	EAG

TABLE I - MATERIAL / FINISH CLASS		
CLASS	SHELL MATERIAL	FINISH
M	ALUMINUM ALLOY	ELECTROLESS NICKEL (RoHS)
MT	ALUMINUM ALLOY	NICKEL-PTFE (RoHS)
NF	ALUMINUM ALLOY	OLIVE DRAB CADMIUM OVER ELECTROLESS NICKEL
ZNU	ALUMINUM ALLOY	BLACK ZINC-NICKEL OVER ELECTROLESS NICKEL (RoHS)
Z1	STAINLESS STEEL	PASSIVATE (RoHS)

CONTACT GLENNAIR FOR ADDITIONAL FINISHES

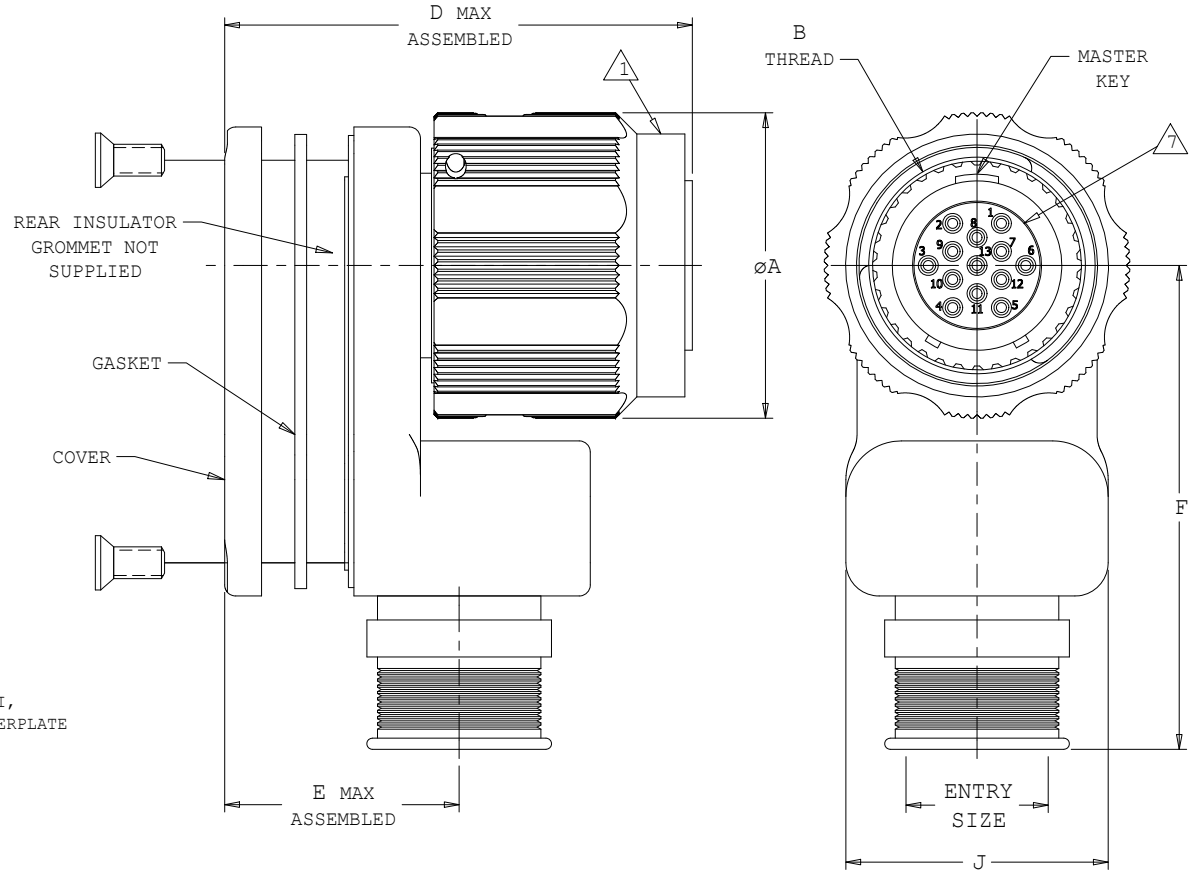

FACE VIEW OF PLUG AS VIEWED FROM ENGAGING END (10-13PA1 SHOWN)

NOTES: UNLESS OTHERWISE SPECIFIED

1. ASSEMBLY TO BE IDENTIFIED WITH GLENNAIR'S NAME, PART NUMBER, AND DATE CODE, SPACE PERMITTING.

2. MATERIAL / FINISH:
 PLUG BARREL, COUPLING NUT, HOUSING, COVER - ALUMINUM ALLOY OR STAINLESS STEEL / SEE TABLE I
 INSULATOR - LCP / NONE.
 INTERFACIAL SEAL, GASKET - FLUOROSILICONE / NONE
 CONTACT - COPPER ALLOY / GOLD PLATE PER ASTM B 488, TYPE II, CODE C, CLASS 1.25 (.00005 MIN THK), OVER A SUITABLE UNDERPLATE
 CONTACT RETENTION CLIP - BERYLLIUM COPPER ALLOY / NONE
 HARDWARE - STAINLESS STEEL / PASSIVATE OR BLACK OXIDE
 RETAINING WIRE - TORLON / NONE
 DETENT SPRING, RIVET - STAINLESS STEEL / PASSIVATE
 EMI GROUND SPRING - BERYLLIUM COPPER / ELECTROLESS NICKEL

3. CONTACTS ARE SIZE 23.
 4. CONSULT FACTORY FOR ADDITIONAL CONTACT ARRANGEMENTS AND/OR SHELL ORIENTATIONS.
 5. CRIMP BARREL ACCOMMODATES 22, 24, 26, AND 28 GAGE WIRE.
 6. CRIMP TOOL DATA:
 A. HAND CRIMP TOOL: GLENNAIR PART NO. 809-015.
 B. POSITIONER FOR HAND TOOL: GLENNAIR PART NO. 809-005.
 C. INSERTION/EXTRACTION TOOL: GLENNAIR PART NO. 809-088.

7. CONTACT ARRANGEMENT, CONTACT GENDER, KEY POSITIONS, AND SHELL ORIENTATION SHOWN ARE FOR REFERENCE ONLY.

8. THIS CONNECTOR MATES WITH ALL QUICK COUPLING, HIGH DENSITY RECEPTACLE CONNECTORS WITH SAME POLARIZATION AND OPPOSITE CONTACT GENDER (805-003 THROUGH 805-006 AND 805-017).

9. REAR INSULATOR GROMMET NOT SUPPLIED.

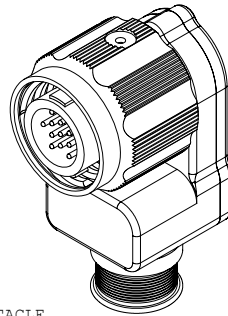

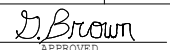
UNLESS OTHERWISE SPECIFIED	DRAWN	EAG	07/19/12	GLENNAIR, INC. 1211 AIR WAY - GLENDALE - CALIFORNIA 91201 TITLE PLUG CONNECTOR, SERIES 805 STYLE RATCHETING COBRA			
DIMENSIONS ARE IN INCHES	CHECK	GSB	07/19/12				
TOLERANCES	ENGR	EAG	07/19/12				
FRACTIONS ± 1/16	 APPROVED			CODE IDENT. NO.	SIZE	DRAWING NO.	REV.
DECIMALS .XX ± .03				06324	A	805-061	B
ANGLES ± 2°				SCALE	N.A.	WEIGHT	N.A.
DO NOT SCALE THIS DRAWING	RELEASE DATE	07/18/12		SHEET	1 OF 2		
B/F 11C8797 P/C 80	ORIGINAL RELEASE DATE	07/18/12					

THIS COPYRIGHTED DOCUMENT IS THE PROPERTY OF GLENAIR, INC. AND IS FURNISHED ON THE CONDITION THAT IT IS NOT TO BE DISCLOSED, REPRODUCED IN WHOLE OR IN PART, OR USED TO SOLICIT QUOTATIONS FROM COMPETITIVE SOURCES, OR USED FOR MANUFACTURE BY ANYONE OTHER THAN GLENAIR, INC. WITHOUT WRITTEN PERMISSION FROM GLENAIR, INC. THE INFORMATION HEREIN HAS BEEN DEVELOPED AT GLENAIR'S EXPENSE AND MAY BE USED FOR ENGINEERING EVALUATION AND INCORPORATION INTO TECHNICAL SPECIFICATIONS AND OTHER DOCUMENTS WHICH SPECIFY PROCUREMENT OF PRODUCTS FROM GLENAIR, INC.

REVISION HISTORY
SEE SHEET 1 OF 2

TABLE II - DIMENSIONAL DATA

SHELL SIZE	øA	B THREAD	D	E	F	G	H	J	MAX ENTRY
8	.65 [15.7]	.5000-.1P-.3L-TS-2B	1.02 [25.9]	.34 [8.6]	1.24 [31.5]	1.76 [44.7]	1.62 [41.1]	.560 [14.22]	04
9	.79 [20.1]	.5625-.1P-.3L-TS-2B	1.03 [26.2]	.39 [9.9]	1.28 [32.5]	1.77 [45.0]	1.63 [41.4]	.650 [16.51]	05
10	.83 [21.1]	.6250-.1P-.3L-TS-2B	1.05 [26.7]	.42 [10.7]	1.31 [33.3]	1.79 [45.5]	1.65 [41.9]	.710 [18.03]	06
11	.92 [23.4]	.6875-.1P-.3L-TS-2B	1.08 [27.4]	.45 [11.4]	1.34 [34.0]	1.82 [46.2]	1.68 [42.7]	.770 [19.56]	07
12	.98 [24.9]	.7500-.1P-.3L-TS-2B	1.11 [28.2]	.48 [12.2]	1.37 [34.8]	1.85 [47.0]	1.71 [43.4]	.835 [21.21]	08
13	1.05 [26.7]	.8125-.1P-.3L-TS-2B	T.B.D.	T.B.D.	T.B.D.	T.B.D.	T.B.D.	T.B.D.	09
15	1.10 [27.9]	.9375-.1P-.3L-TS-2B	1.17 [29.7]	.52 [13.2]	1.48 [37.6]	1.91 [48.5]	1.77 [45.0]	.950 [24.13]	10
18	1.29 [32.8]	1.1250-.1P-.3L-TS-2B	T.B.D.	T.B.D.	T.B.D.	T.B.D.	T.B.D.	T.B.D.	12
19	1.31 [33.3]	1.1875-.1P-.3L-TS-2B	1.32 [33.5]	.63 [16.0]	1.78 [45.2]	2.06 [52.3]	1.92 [48.8]	1.180 [29.97]	13
21	1.45 [36.8]	1.3125-.1P-.3L-TS-2B	T.B.D.	T.B.D.	T.B.D.	T.B.D.	T.B.D.	T.B.D.	15
23	1.56 [39.6]	1.4375-.1P-.3L-TS-2B	T.B.D.	T.B.D.	T.B.D.	T.B.D.	T.B.D.	T.B.D.	17

TABLE VI-CABLE ENTRY

CODE	ENTRY SIZE
02	.125
03	.188
04	.250
05	.313
06	.375
07	.438
08	.500
09	.563
10	.625
11	.688
12	.750
13	.813
14	.875
15	.938
16	1.000
17	1.063

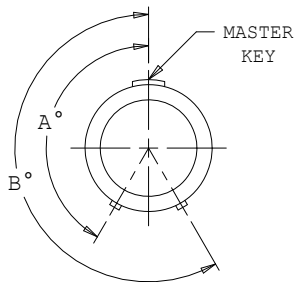

POSITION	A°	B°
A (NORMAL)	150°	210°
B	75°	210°
C	95°	230°
D	140°	275°
E	75°	275°
F	95°	210°

KEY POSITION
(POSITION A SHOWN)

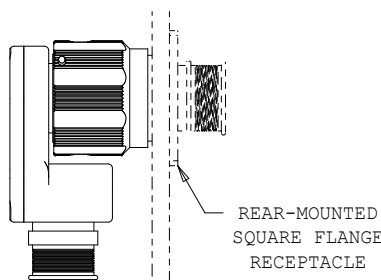

SHOWN INSTALLED

DIRECTION	C°
1	0°
2	45°
3	90°
4	135°
5	180°
6	225°
7	270°
8	315°

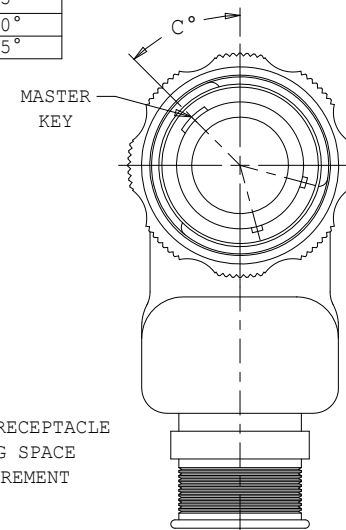

CABLE EXIT DIRECTION
(DIRECTION 2 SHOWN)

PART NUMBER DEVELOPMENT

EXAMPLE: 805-061 -16 ZNU 9-10 P A 1 05

CONNECTOR SERIES

SHELL STYLE

-16 = PLUG CONNECTOR WITH RATCHETING ANTI-DECOUPLING MECHANISM

CLASS (SEE TABLE I)

SHELL SIZE - CONTACT ARRANGEMENT
(SEE TABLE V)

CONTACT STYLE

- A = PIN, SOLDER
- B = SOCKET, SOLDER
- P = PIN, CRIMP
- S = SOCKET, CRIMP

KEY POSITION

A THROUGH F (SEE TABLE III)

CABLE EXIT DIRECTION

1 THROUGH 8 (SEE TABLE IV)

CABLE ENTRY SIZE (SEE TABLE VI)

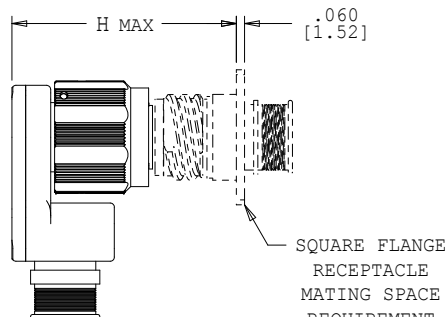

SQUARE FLANGE RECEPTACLE MATING SPACE REQUIREMENT

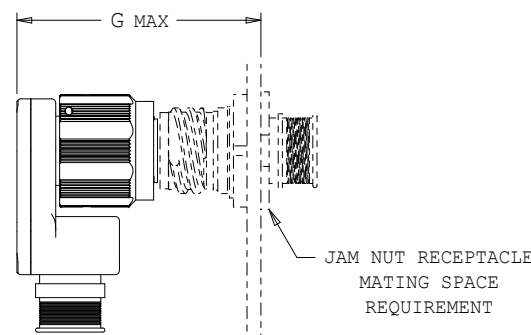

JAM NUT RECEPTACLE MATING SPACE REQUIREMENT

SHELL SIZE	CONTACT ARRANGEMENT*
8	8-4, 8-6, 8-7
9	9-10
10	10-13
11	11-19
12	12-26
13	13-31
15	15-37
18	18-55
19	19-85
21	21-100
23	23-130

*: # FOLLOWING DASH = # OF CONTACTS

UNLESS OTHERWISE SPECIFIED DIMENSIONS ARE IN INCHES TOLERANCES FRACTIONS ± 1/16 DECIMALS .XX ± .03 .XXX ± .015 ANGLES ± 2°	DRAWN	EAG	07/19/12	GLENAIR, INC. 1211 AIR WAY - GLENDALE - CALIFORNIA 91201 TITLE PLUG CONNECTOR, SERIES 805 STYLE RATCHETING COBRA	CODE IDENT. NO. 06324 SIZE A DRAWING NO. 805-061 REV. B
	CHECK	GSB	07/19/12		
	ENGR	EAG	07/19/12		
DO NOT SCALE THIS DRAWING	RELEASE DATE	07/18/12	APPROVED <i>D. Brown</i>	SCALE	N.A.
B/F 11C8797/P/C 80	RELEASE DATE	07/18/12	APPROVED	WEIGHT	N.A.
				SHEET	2 OF 2

Mouser Electronics

Authorized Distributor

Click to View Pricing, Inventory, Delivery & Lifecycle Information:

Glenair:

[801-069-26M6-7SA704](#) [801-069-26M6-7SA204](#) [801-007-26NF6-7SA](#) [801-007-26M16-55PA](#) [801-009-07MT10-26SB](#)
[801-007-26M10-2SA](#) [801-008-16M21-130PA](#) [801-009-07M10-2SA](#) [801-009-01M6-23PA](#) [801-007-16M11-31PA](#)
[801-007-16M10-2PA](#) [801-008-26M6-7SA](#) [801-008-26M9-19SA](#) [801-007-16UCR9-19PA](#) [801-009-02NF8-13PA](#) [801-069-26M7-10SA805](#)