

4-Channel 240mA Linear LED Driver with Ultra-Low Dropout Current Source

Features

- Single PWM Control Four Channel High-Accuracy Current Regulation, ON/OFF Dimming:
 - Up to 240mA Output Current in DC per Channel, and 350mA in 330 μ s Pulse
 - \pm 5% Current Accuracy
 - LED Currents Set through External Resistors
- High LED Input Voltage up to 25V
- 2.7V~5.5V Input Voltage Range
- Low Dropout Current Source (0.3V at 175mA, 0.32V at 240mA)
- Diagnosis and protection
 - Thermal Shutdown
 - Zero Current Shutdown Mode
- Working Temperature Range -40 $^{\circ}$ C ~ 105 $^{\circ}$ C
- FCDFN 2mm x 3mm -8L package

Applications

IR Cameras
VR Handles
Illuminating Equipments

Typical Application Circuit

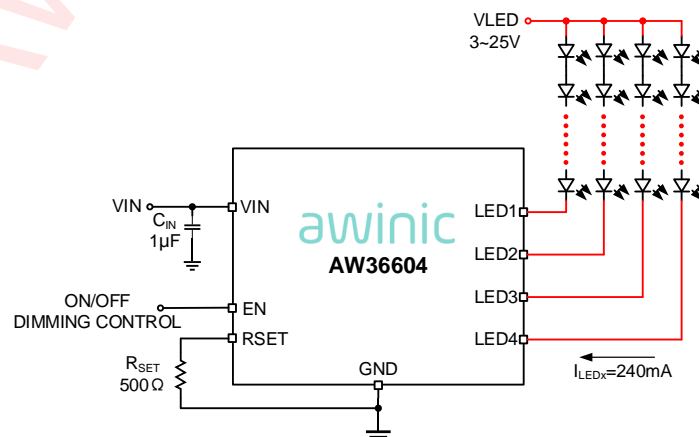

Figure 1 AW36604 Application circuit

General Description

AW36604 is a 4-channel, linear current sink LED/IR driver with an ultra-low dropout voltage. Each channel drives a high brightness LED string with a current of up to 240mA in DC, and 350mA in 330 μ s pulse.

The output current is configured by the external resistor connected to the RSET pin and ground.

The LED pins can support high voltage application up to 25V for multiple LED string applications.

AW36604 provides EN pin which can be used for hardware enable and ON/OFF dimming PWM signal input.

AW36604 has an over temperature shutdown function, which prohibits LED output when the chip temperature exceeds 150 $^{\circ}$ C.

Pin Configuration And Top Mark

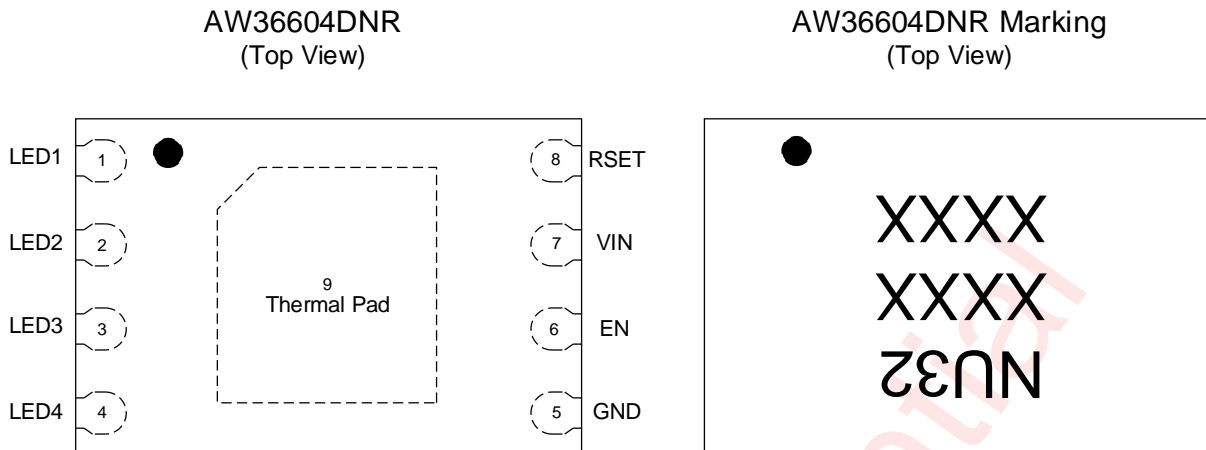

NU32- AW36604DNR
XXXX/XXXX- Production Tracing Code

Figure 2 Pin Configuration and Top Mark

No.	NAME	DESCRIPTION
1	LED1	Constant current sink, connect to LED1's cathode.
2	LED2	Constant current sink, connect to LED2's cathode.
3	LED3	Constant current sink, connect to LED3's cathode.
4	LED4	Constant current sink, connect to LED4's cathode.
5	GND	Ground.
6	EN	Enable control and PWM dimming input. Logic high input to enable the device. With an internal pull-down resistor to GND.
7	VIN	Power supply: 2.7~5.5V.
8	RSET	LED current set pin for the LED1~4 channels.
9	Thermal Pad	Connect to Ground.

Functional Block Diagram

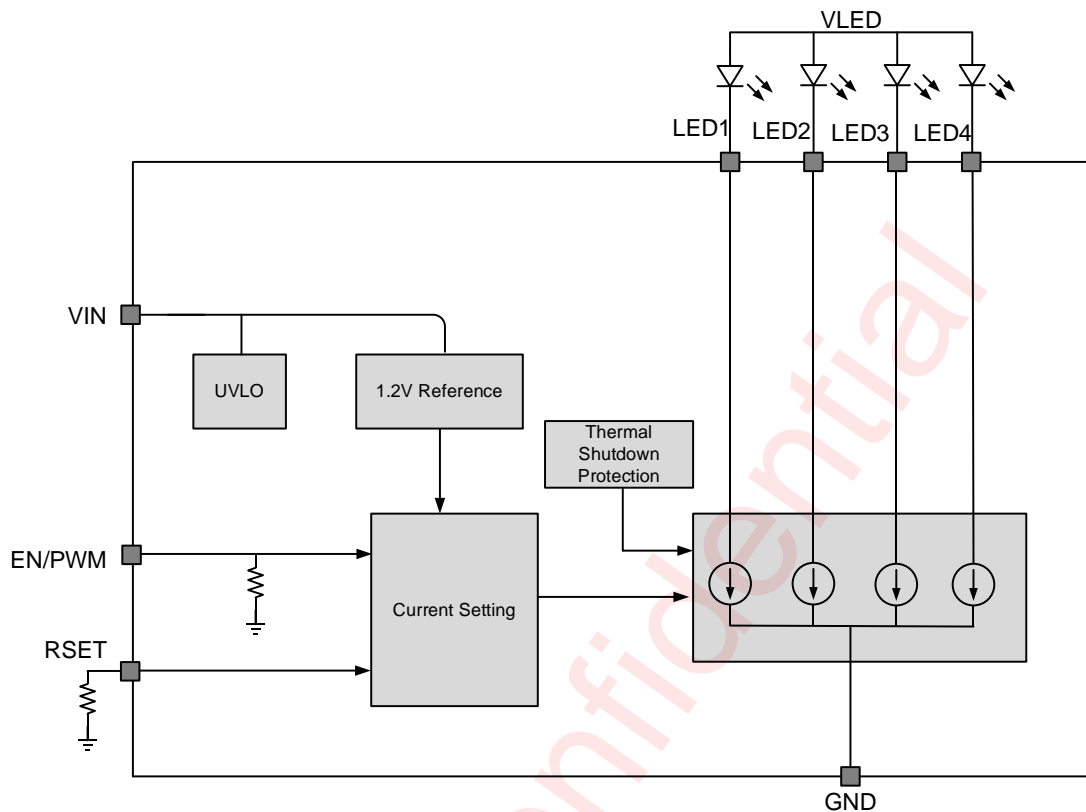

Figure 3 AW36604 Function Block

Typical Application Circuits

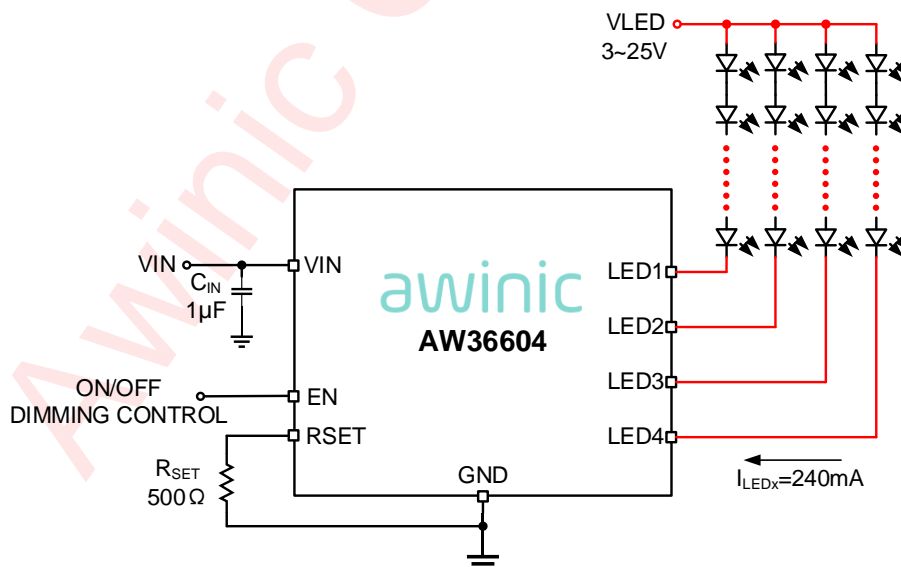

Figure 4 AW36604 Application circuit

Notice for typical application circuits:

- 1: Please place C_{IN} as close to the chip as possible, and R_{SET} close to RSET pin and GND pin.
- 2: The voltage of VLED is determined by V_F of LED strings and dropout voltage required to support the current: $V_{LED} > V_F + V_{DROP}$
- 3: Red lines are high current paths, please reserve sufficient route width.

Ordering Information

Part Number	Temperature	Package	Marking	Moisture Sensitivity Level	Environmental Information	Delivery Form
AW36604DNR	-40°C~105°C	WBDFN 2mm x 3mm-8L	NU32	MSL1	ROHS+HF	3000 units/ Tape and Reel

Absolute Maximum Ratings^(NOTE1)

PARAMETERS		RANGE
Supply voltage range V_{IN}		-0.3V to 6V
Input voltage range	EN, RSET	-0.3V to V_{IN}
Output voltage range	LED1, LED2, LED3, LED4	-0.3V to 25V
Junction-to-ambient thermal resistance θ_{JA}		78.7°C /W
Maximum operating junction temperature T_{JMAX}		150°C
Storage temperature T_{STG}		-65°C to 150°C
Lead temperature (soldering 10 seconds)		260°C
ESD (NOTE 2)		
HBM		±2kV
CDM		±1.5kV
Latch-Up		
Test condition: JESD78F		+IT: 200mA -IT: -200mA

NOTE1: Conditions out of those ranges listed in "absolute maximum ratings" may cause permanent damages to the device. In spite of the limits above, functional operation conditions of the device should be within the ranges listed in "recommended operating conditions". Exposure to absolute-maximum-rated conditions for prolonged periods may affect device reliability.

NOTE2: The human body model is a 100pF capacitor discharged through a 1.5kΩ resistor into each pin. Test method: ESDA/JEDEC JS-001-2023. CDM test method: ESDA/JEDEC JS-002-2022.

Recommended Operating Conditions

Symbol	Parameter	Min.	Typ.	Max.	Unit
V _{IN}	Input voltage	2.7		5.5	V
V _{LED_OFF}	Voltage applied to LED1 to LED4, outputs off			25	V
V _{LED_ON}	Voltage applied to LED1 to LED4, outputs on			6	V
C _{IN}	Input capacitance	0.1	1	10	μF
R _{SET}	Current set resistor	330		12k	Ω
T _A	Operating free-air temperature range	-40°	25	105	°C

Awinic Confidential

Electrical Characteristics

VIN=VEN=5V, VLEDX=4V, TA=25°C for typical values (unless otherwise noted)

PARAMETER		TEST CONDITION	MIN	TYP	MAX	UNIT
SUPPLY VOLTAGE AND INPUT CURRENTS						
ISD	Shutdown current	VEN=0V		0.1	1	μA
IQ	Quiescent current	RSET floating		0.6	1	mA
		RSET=680Ω		6		mA
		RSET=500Ω		8.5		mA
VUVLO	Under-voltage lockout threshold	VIN falling		2		V
VHYS	Under-voltage lockout hysteresis			0.2		V
CURRENT SINK						
I _{LED_ACC}	LED current accuracy	I _{LEDX} =240mA	-5		5	%
I _{LED_MAT}	LED current matching	I _{LEDX} =240mA	-5		5	%
VDROP	Dropout voltage	I _{LEDX} =240mA		320		mV
		I _{LEDX} =175mA		300		mV
RSET						
VRSET	Output voltage of RSET pin		1.18	1.2	1.21	V
I _{LED} /I _{RSET}	RSET to LED Current gain ratio	I _{LEDX} =240mA		100		
ENABLE						
VIH	EN logic high voltage		1.2			V
VIL	EN logic low voltage				0.4	V
R _{PD}	EN pull-down resistor			170		kΩ
T _{STARTUP}	Startup time			0.9		μs
T _{SHUTDOWN}	Shutdown delay time			4	8	ms
T _{ON}	EN pull high to I _{LED} rise time	I _{LEDX} =240mA		540		ns
		I _{LEDX} =175mA		450		ns
T _{OFF}	EN pull low to I _{LED} fall time	I _{LEDX} =240mA		540		ns
		I _{LEDX} =175mA		450		ns
T _{HI}	EN high time for dimming		5			μs
T _{LOW}	EN low time for dimming		1.2			μs
T _{RISE}	I _{LED} rise time	I _{LEDX} =240mA		650		ns
		I _{LEDX} =175mA		500		ns
T _{FALL}	I _{LED} fall time	I _{LEDX} =240mA		500		ns
		I _{LEDX} =175mA		400		ns
THERMAL SHUTDOWN						
T _{SD}	Thermal shutdown threshold			150		°C

PARAMETER		TEST CONDITION	MIN	TYP	MAX	UNIT
T_{HYS}	Thermal shutdown hysteresis			25		°C

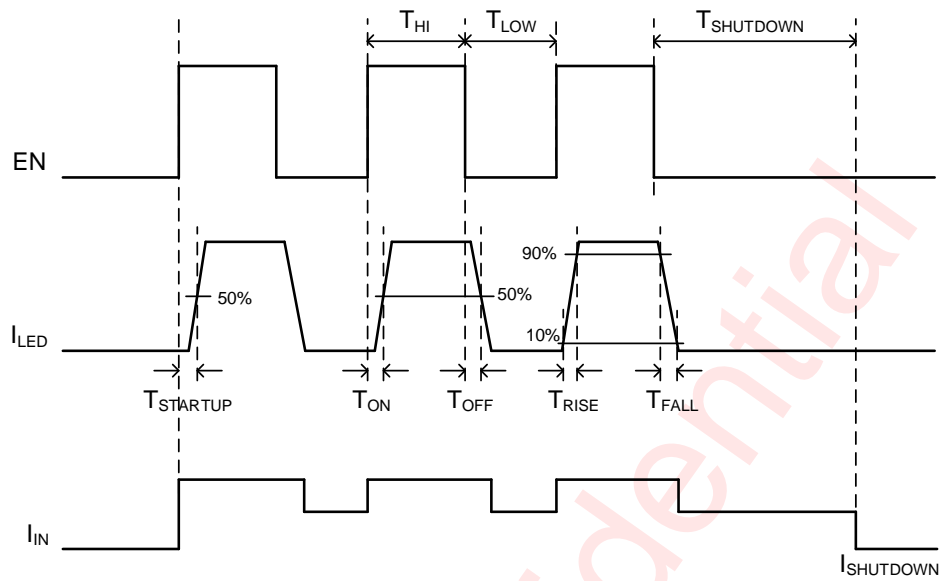
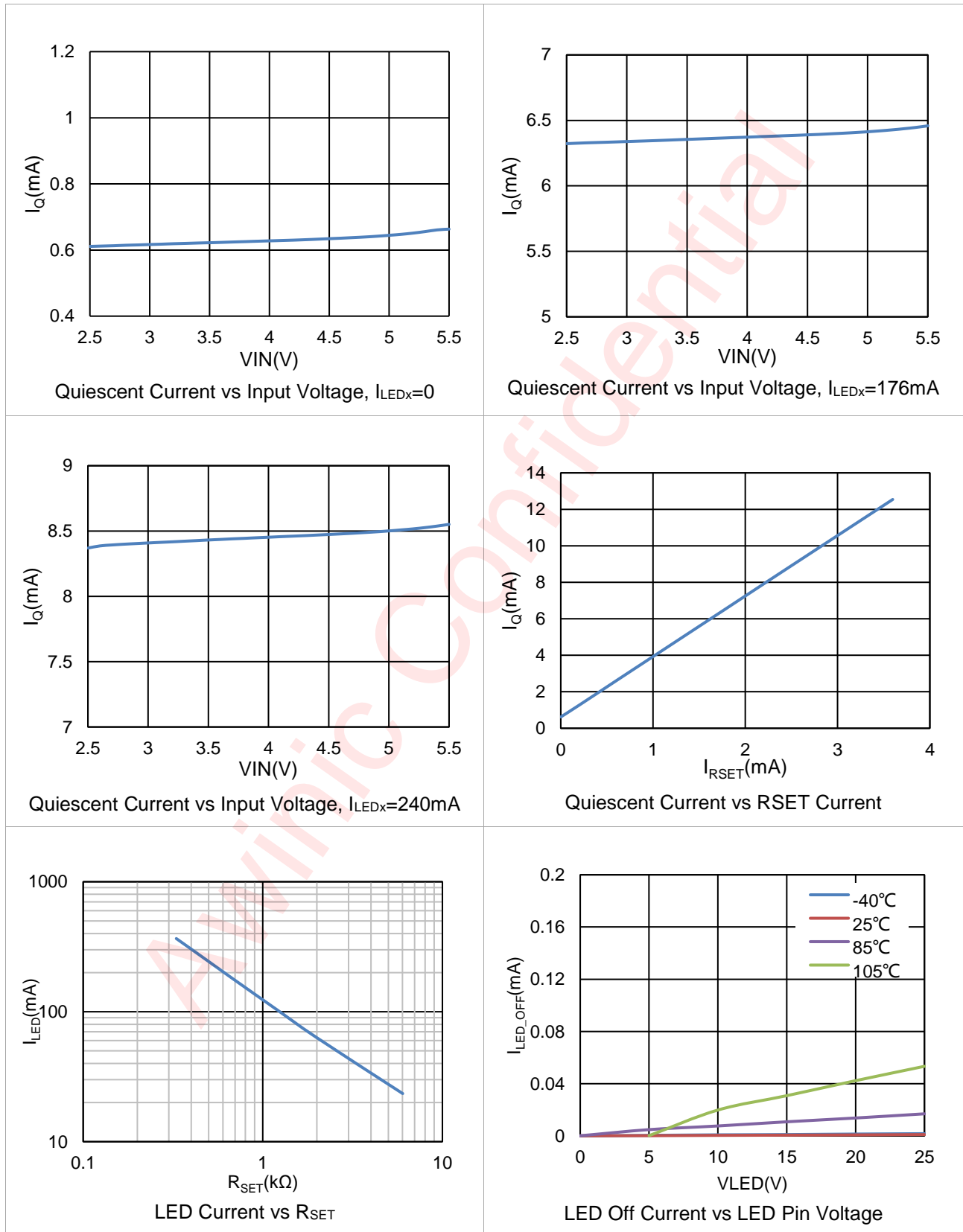
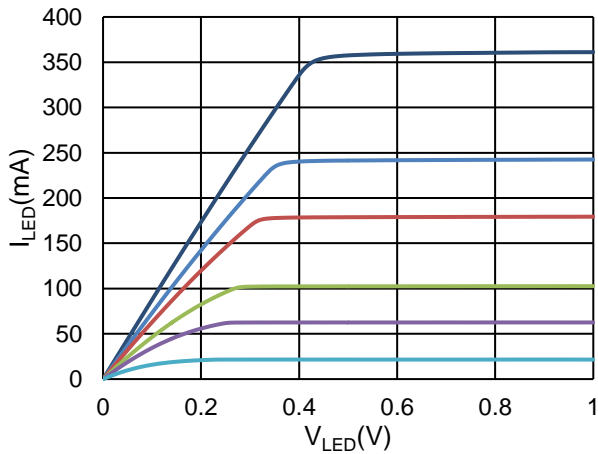

Figure 5 EN and Output Current Timing

Typical Characteristics

V_{IN}=5V, V_{LEDx}=5V, LED forward voltage=1.8V@240mA, C_{IN}=1μF, T_A=25°C, Circuit of figure 4 unless other noted.





LED Current vs LED Pin Voltage

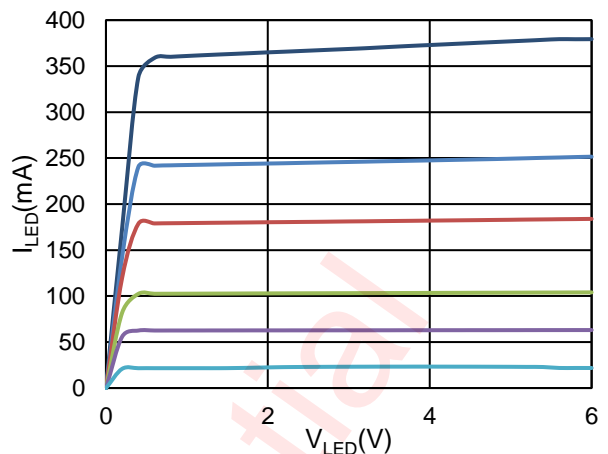

LED Current vs LED Pin Voltage

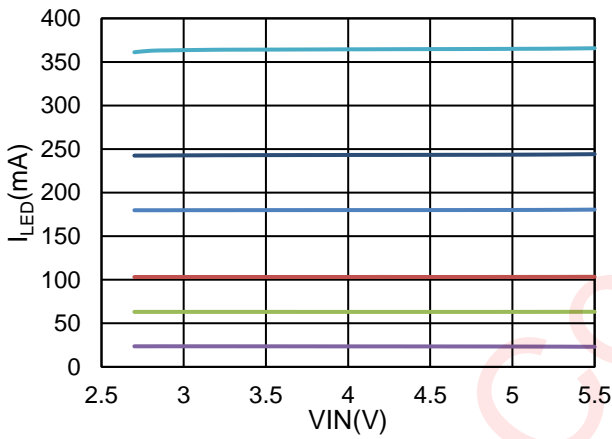

LED Current vs Input Voltage

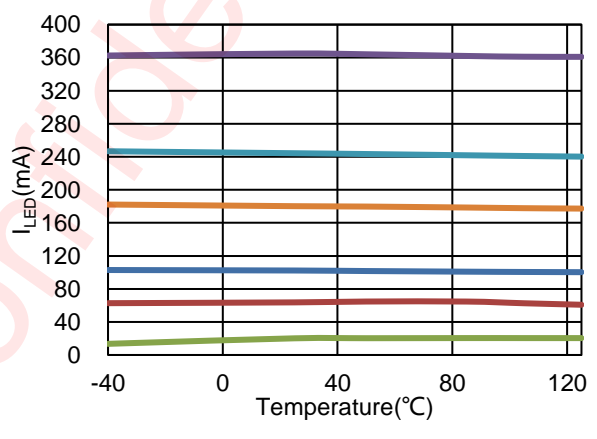

LED Current vs Temperature

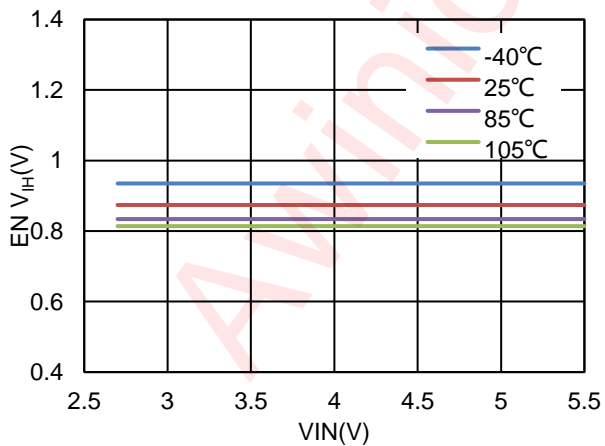

EN Threshold vs Input Voltage

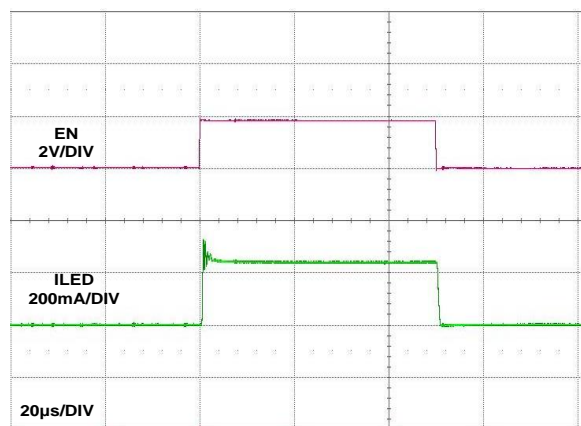

1% Duty Cycle @200Hz PWM Signal on EN Pin

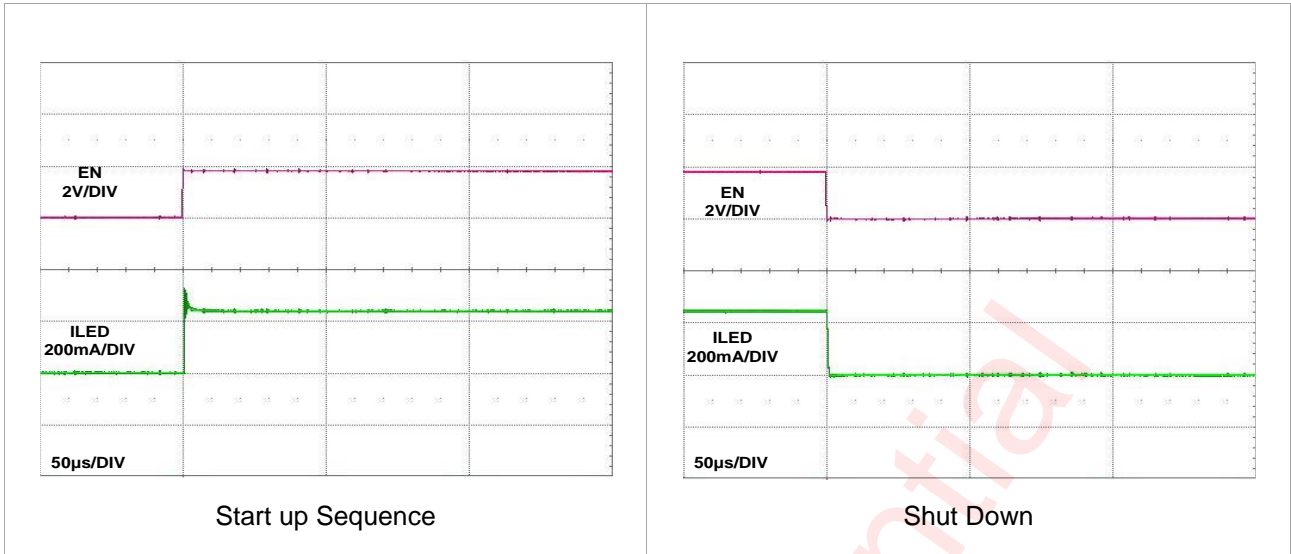

Awinic Confidential

Detailed Functional Description

AW36604 is a 4-channel, low dropout voltage, high voltage, linear current source LED/IR driver. Each channel drives a high brightness LED string with a current of up to 240mA and 350mA for 330 μ s. The LED channel current is configured by an external resistor on the RSET pin.

Enable/Shutdown

The EN pin is used for enable device and ON/OFF dimming. When pull EN high, AW36604 enters Active Mode, and begins to output current. When pull EN low, the output current will be closed. When the EN voltage is logic low for more than 8ms, the driver will be shut down.

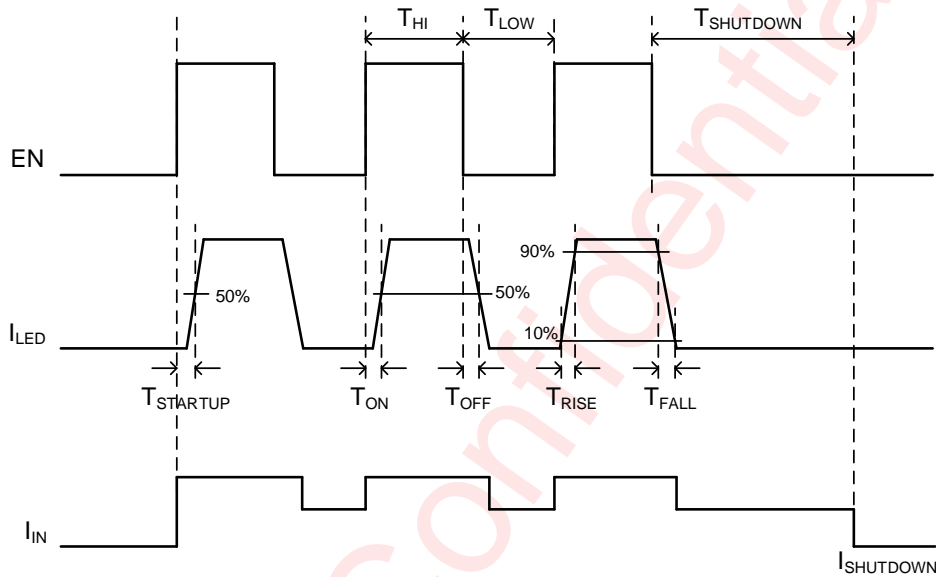

Figure 6 EN and Output Current Timing

Under Voltage Lockout (UVLO)

The AW36604 has an internal comparator that monitors the input voltage. If the input voltage drops below 2V, the device will be turned off. And it will recover to the normal operation when the input voltage rises above 2.2V.

Thermal Shutdown (TSD)

An internal thermal shutdown turns off the device when the typical junction temperature exceed 150°C. The device will restart when the junction temperature decreases by 25°C.

Application Information

Output Current Setting

The LED current is programmed externally using a resistor in series with the LED string. The value of the RSET can be calculated by the following equation:

$$I_{LED} = 100 \times \frac{V_{RSET}}{R_{SET}}$$

Where I_{LED} is output current of per channel, $V_{RSET} = 1.2V$, R_{SET} is the current sense resistor connected to RSET pin.



Figure 7 External Resistor Configuration

Thermal Consideration

To avoid the AW36604 from exceeding the maximum junction temperature, the user will need to do some thermal analysis. The goal of the thermal analysis is to determine whether the power dissipated exceeds the recommended junction temperature of the part. The power dissipated by the part is approximated:

$$P_D \cong \sum_{i=1}^4 (V_{LEDi} \times I_{LEDi})$$

Where V_{LEDi} is the voltage on each LED pin, I_{LEDi} is the output current of each channel. And the temperature rise is given by:

$$\Delta T = P_D \cdot \theta_{JA}$$

Where P_D is the power dissipated by the regulator, The θ_{JA} is the thermal resistance from the junction of the die to the ambient temperature. The junction temperature, T_J is given by:

$$T_J = T_A + \Delta T$$

Where T_A is the ambient temperature.

PCB Layout Consideration

AW36604 is a 4-channel high voltage current sink chip, to obtain the optimal performance, PCB layout should be considered carefully. Here are some guidelines:

1. Please place C_{IN} as close to the chip as possible.
2. Please place R_{SET} as close to RSET and GND pin to achieve high current accuracy.
3. Connect the exposed paddle to the PCB ground plane using at least four vias.

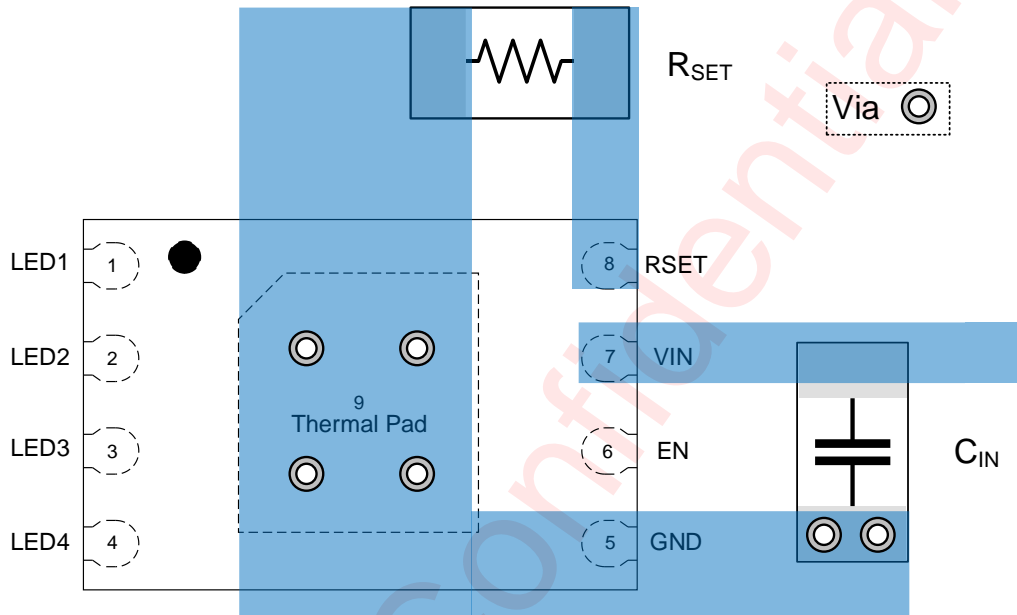

Tape And Reel Information

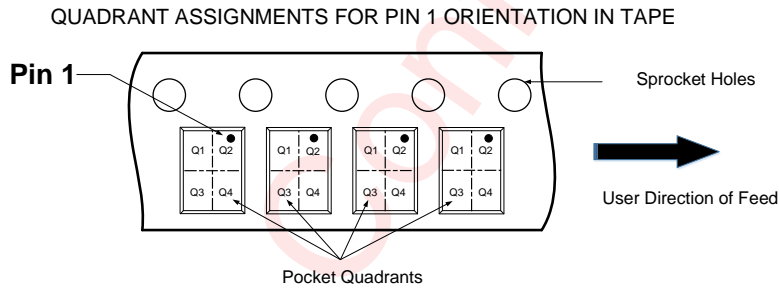
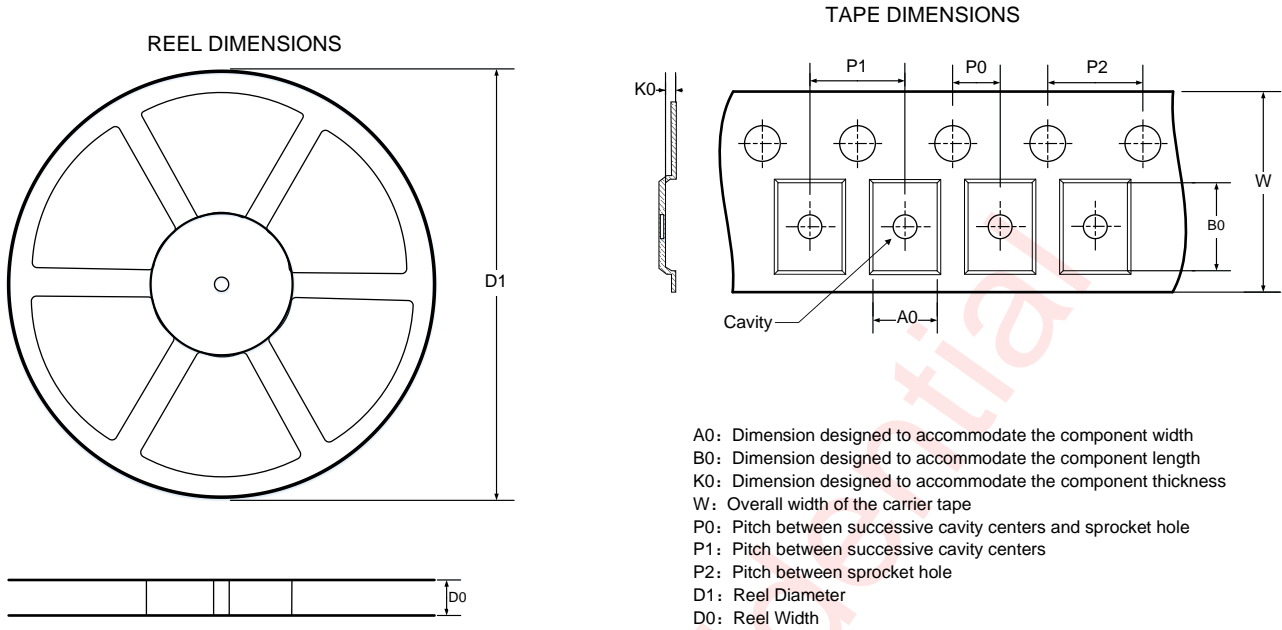

Note: The above picture is for reference only. Please refer to the value in the table below for the actual size

DIMENSIONS AND PIN1 ORIENTATION

D1 (mm)	D0 (mm)	A0 (mm)	B0 (mm)	K0 (mm)	P0 (mm)	P1 (mm)	P2 (mm)	W (mm)	Pin1 Quadrant
180	8.6	2.3	3.3	0.95	2	4	4	8	Q2

All dimensions are nominal

Package Description

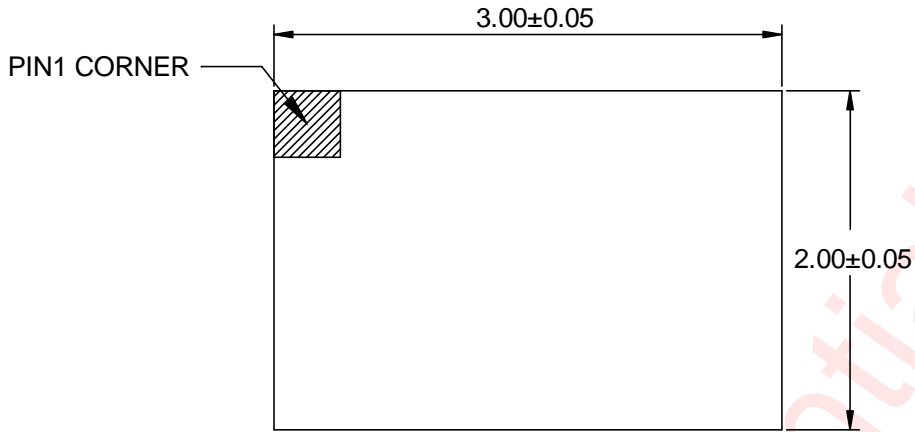

Top View

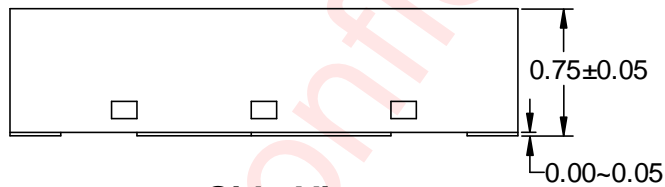

Side View

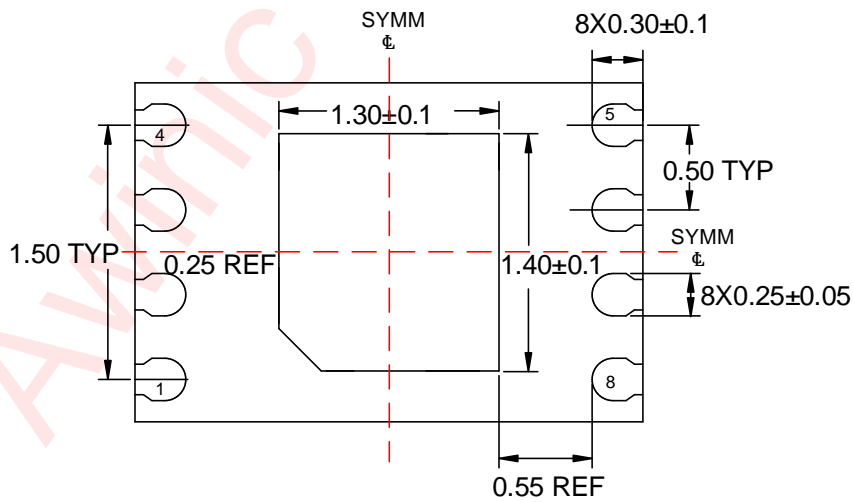

Bottom View

Unit: mm

Land Pattern Data

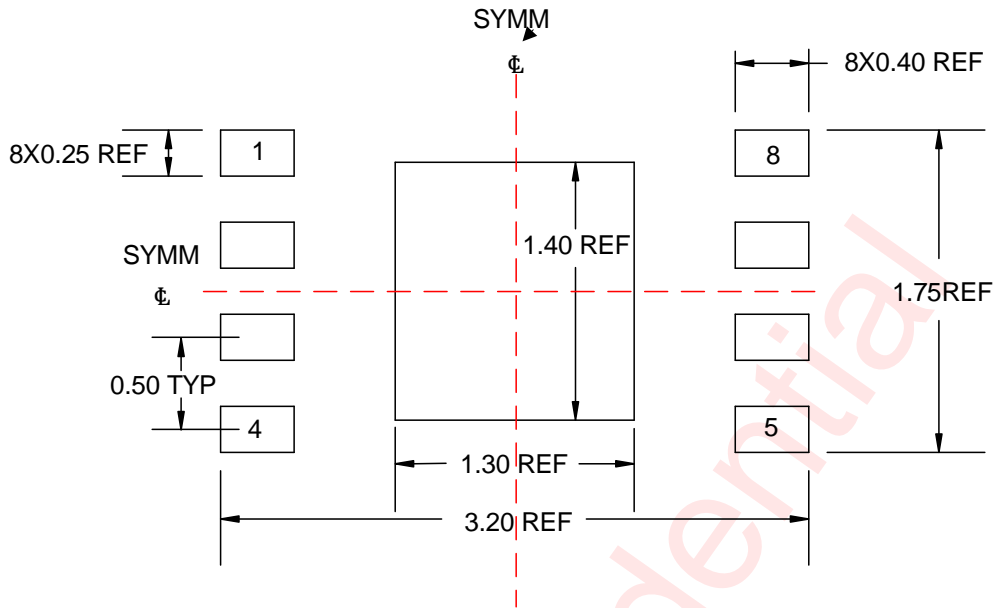

0.05 MAX
All AROUND

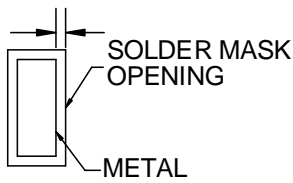

NON SOLDER MASK DEFINED

0.05 MIN
All AROUND

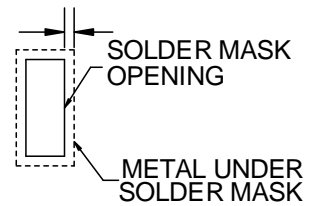

SOLDER MASK DEFINED

Unit: mm

REVISION HISTORY

Version	Date	Change Record
V1.0	Sep.2024	Officially released

Awinic Confidential

Disclaimer

All trademarks are the property of their respective owners. Information in this document is believed to be accurate and reliable. However, Shanghai AWINIC Technology Co., Ltd (AWINIC Technology) does not give any representations or warranties, expressed or implied, as to the accuracy or completeness of such information and shall have no liability for the consequences of use of such information.

AWINIC Technology reserves the right to make changes to information published in this document, including without limitation specifications and product descriptions, at any time and without notice. Customers shall obtain the latest relevant information before placing orders and shall verify that such information is current and complete. This document supersedes and replaces all information supplied prior to the publication hereof.

AWINIC Technology products are not designed, authorized or warranted to be suitable for use in medical, military, aircraft, space or life support equipment, nor in applications where failure or malfunction of an AWINIC Technology product can reasonably be expected to result in personal injury, death or severe property or environmental damage. AWINIC Technology accepts no liability for inclusion and/or use of AWINIC Technology products in such equipment or applications and therefore such inclusion and/or use is at the customer's own risk.

Applications that are described herein for any of these products are for illustrative purposes only. AWINIC Technology makes no representation or warranty that such applications will be suitable for the specified use without further testing or modification.

All products are sold subject to the general terms and conditions of commercial sale supplied at the time of order acknowledgement.

Nothing in this document may be interpreted or construed as an offer to sell products that is open for acceptance or the grant, conveyance or implication of any license under any copyrights, patents or other industrial or intellectual property rights.

Reproduction of AWINIC information in AWINIC data books or data sheets is permissible only if reproduction is without alteration and is accompanied by all associated warranties, conditions, limitations, and notices. AWINIC is not responsible or liable for such altered documentation. Information of third parties may be subject to additional restrictions.

Resale of AWINIC components or services with statements different from or beyond the parameters stated by AWINIC for that component or service voids all express and any implied warranties for the associated AWINIC component or service and is an unfair and deceptive business practice. AWINIC is not responsible or liable for any such statements.