



current transformer 400/5A 5VA CL 0.2s

Model	
product brand name	SENTRON
product designation	Current transformer
design of the product	Bushing-type current transformers
product quality calibrated	No
size of the current transformer	1
operating apparent power rated value	5 VA
insulation voltage rated value	3 kV
designation of overcurrent limiting factor	FS 5
operational current rated value maximum	480 A
current	
• at input rated value	400 A
• at output rated value	5 A
value range of the operating frequency	50/60 Hz
Protection class	
protection class IP	IP20
suitability for use	
• for outside use	No
• for interior use	Yes
product feature touch protection	Yes
Connections	
type of electrical connection at output	screw-type terminals
Mechanical Design	
height	75 mm
width	60 mm
width of the push-through bus bar at 1 bus bar maximum	20 mm
width of the push-through bus bar in case of 2 bus bars maximum	20 mm
depth	55 mm
fastening method	screw fixing
diameter of inlet opening	19 mm
outer diameter of the push-through conductor maximum	19 mm
net weight	468 g
Environmental conditions	
ambient temperature during operation	
• minimum	-30 °C
• maximum	55 °C
ambient temperature during storage	
• minimum	-30 °C
• maximum	70 °C

Approvals Certificates

General Product Approval

other



[Confirmation](#)



[Miscellaneous](#)

[Confirmation](#)

Environment

[Environmental Confirmations](#)

Further information

Information on the packaging

<https://support.industry.siemens.com/cs/ww/en/view/109813875>

Information- and Downloadcenter (Catalogs, Brochures,...)

<http://www.siemens.com/lowvoltage/catalogs>

Industry Mall (Online ordering system)

<https://mall.industry.siemens.com/mall/en/en/Catalog/product?mifb=4NC5125-2FE21>

Service&Support (Manuals, Certificates, Characteristics, FAQs,...)

<https://support.industry.siemens.com/cs/ww/en/ps/4NC5125-2FE21>

Image database (product images, 2D dimension drawings, 3D models, device circuit diagrams, ...)

http://www.automation.siemens.com/bilddb/cax_en.aspx?mifb=4NC5125-2FE21

CAX-Online-Generator

<http://www.siemens.com/cax>

Tender specifications

<http://www.siemens.com/specifications>

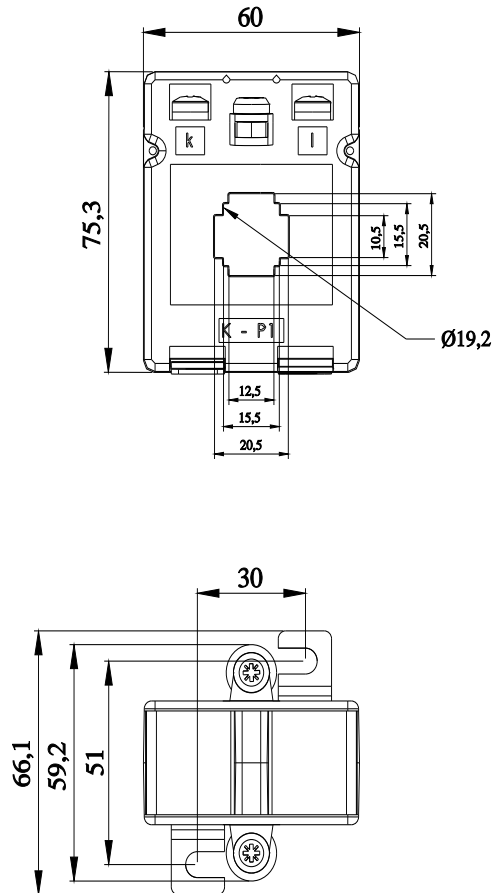

last modified:

5/24/2024

