

## Precision Programmable Reference

### Features

- Reference voltage tolerance at 25°C
  - 0.5% (B Grade)
  - 0.8% (A Grade)
- Sink current capability: 1mA to 100mA
- 0.2Ω Typical output impedance
- Adjustable output voltage:  $V_{REF}$  to 36V
- High stability under capacitive load
- Typical temperature drift: 5mV
- Low output noise
- Operation from -40°C up to 125°C
- Package type: SOT23-3L and SOT23-5L

### Applications

- Power
- Current sensing
- Led lighting
- Industry
- Instrumentation
- Voltage monitoring
- Comparator with integrated reference

### General Description

The AWS7343XXX are adjustable shunt voltage references with guaranteed temperature stability over the operating temperature range. The device temperature range is extended from -40°C up to +125°C. The output voltage can be set to any value between  $V_{REF}$  and 36V with two external resistors. The AWS7343XXX operates with a wide current range from 1mA to 100mA with a typical dynamic impedance of 0.2Ω.

### Device Comparison

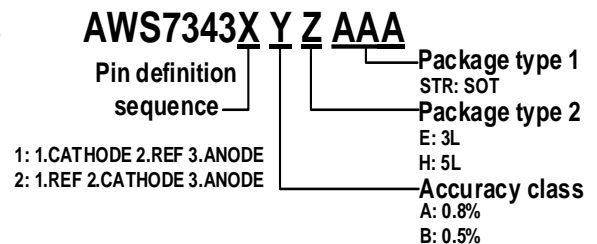

## Typical Application Circuit

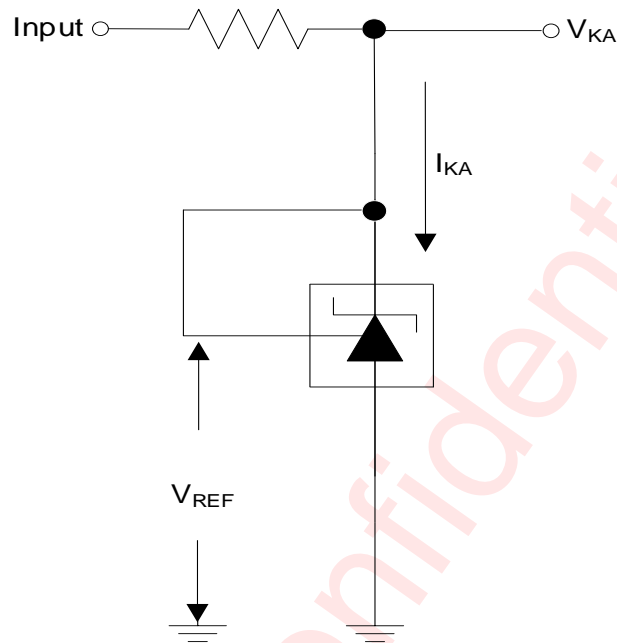

Figure 1 Typical Application Circuit of AWS7343XXX

All the trademarks mentioned in the document are the property of their owners.

**Pin Configuration And Top Mark**

SOT23-3L

**AWS73431XX  
Top View**

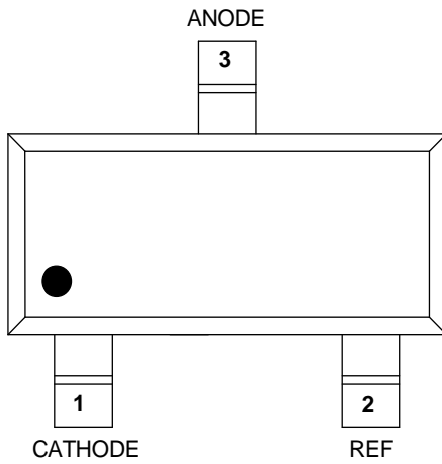

**AWS73431XX Marking  
Top View**

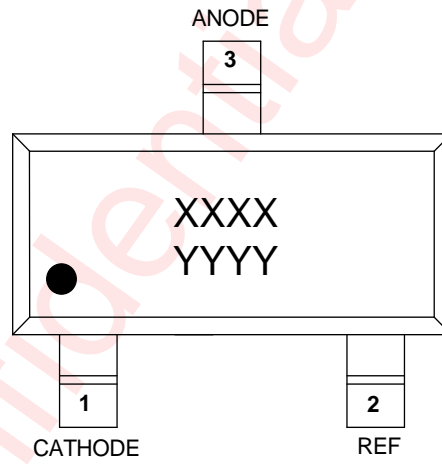

XXXX - Refer to Ordering Information of Marking  
YYYY - Production Tracing Code

**AWS73432XX  
Top View**

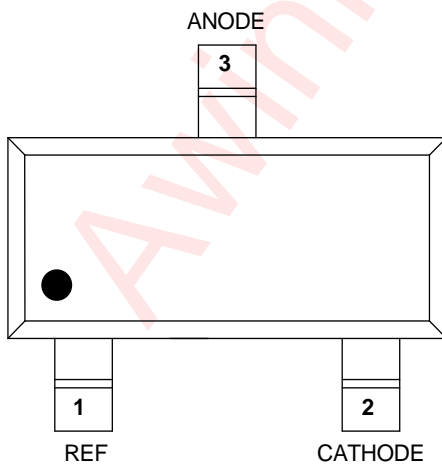

**AWS73432XX Marking  
Top View**

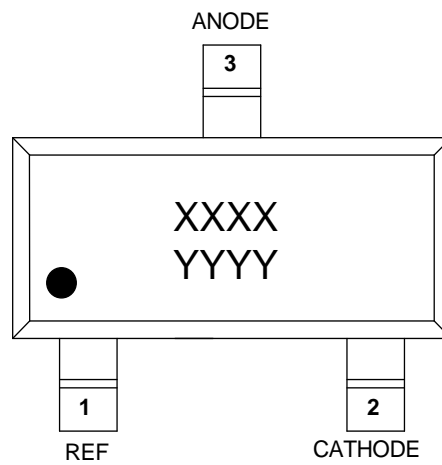

XXXX - Refer to Ordering Information of Marking  
YYYY - Production Tracing Code

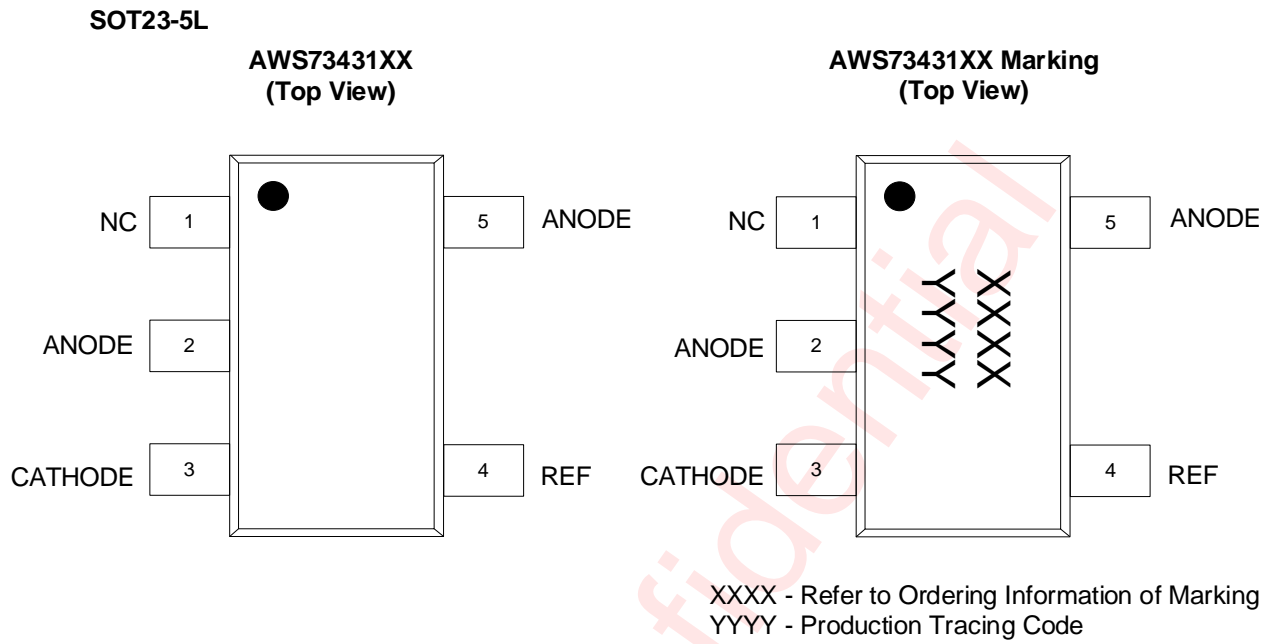

**Figure 2 Pin Configuration and Top Mark**

## Pin Definition

No.	NAME	DESCRIPTION
AWS73431AESTR AWS73431BESTR		
1	CATHODE	Supply voltage/Shunt current.
2	REF	Threshold relative to the universal anode.
3	ANODE	Ground.
AWS73432AESTR AWS73432BESTR		
1	REF	Threshold relative to the universal anode.
2	CATHODE	Supply voltage/Shunt current.
3	ANODE	Ground.
AWS73431AHSTR AWS73431BHSTR		
1	NC	Not connected
2	ANODE	Must be connected to anode(Pin5).
3	CATHODE	Supply voltage/Shunt current.
4	REF	Threshold relative to the universal anode.
5	ANODE	Ground.

## Functional Block Diagram

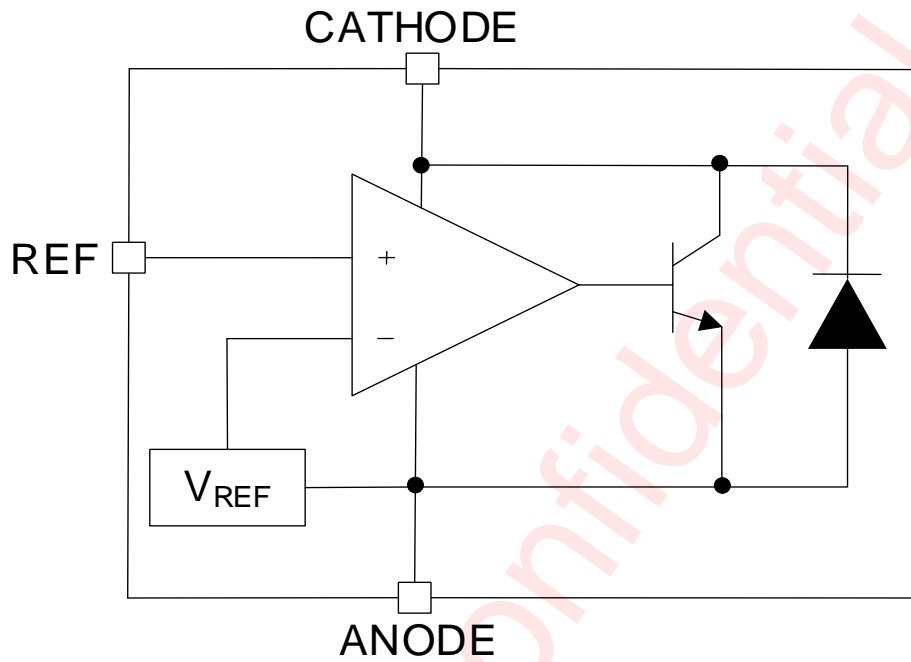

Figure 3 Functional Block Diagram

## Typical Application Circuits

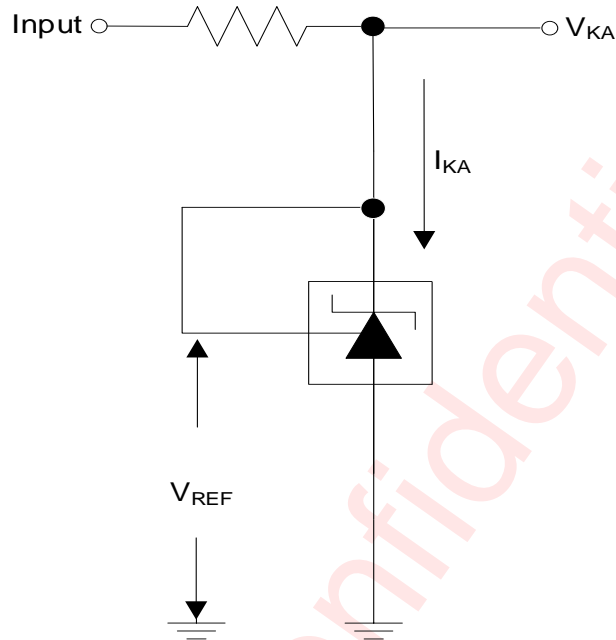

Figure 4 Typical Application Circuit of AWS7343XXX

Notice for Typical Application Circuits:

1. The AWS7343XXX operates with a wide current range from 1mA to 100mA(MAX).

## Ordering Information

Part Number	Temperature	Package	Marking	Moisture Sensitivity Level	Environmental Information	Delivery Form
AWS73431AESTR	-40°C~125°C	SOT23-3L	SKXC	MSL1	ROHS+HF	3000 units/ Tape and Reel
AWS73431BESTR	-40°C~125°C	SOT23-3L	SDL2	MSL1	ROHS+HF	3000 units/ Tape and Reel
AWS73431AHSTR	-40°C~125°C	SOT23-5L	3078	MSL1	ROHS+HF	3000 units/ Tape and Reel
AWS73431BHSTR	-40°C~125°C	SOT23-5L	XA1X	MSL1	ROHS+HF	3000 units/ Tape and Reel

Awinic Confidential

**Absolute Maximum Ratings**<sup>(NOTE1)</sup>

PARAMETERS	RANGE
Cathode voltage $V_{KA}$ <sup>(NOTE1)</sup>	40V
Continuous cathode current $I_{KA}$	-100mA to 100mA
Maximum operating junction temperature $T_{JMAX}$	150°C
Junction-to-ambient thermal resistance $\theta_{JA}$	248°C/W
Operating free-air temperature range	-40°C to 125°C
Storage temperature $T_{STG}$	-65°C to 150°C
Lead temperature (soldering 10 seconds)	260°C
ESD	
Human Body Model (All pins, per JEDEC JS-001) <sup>(NOTE2)</sup>	±4kV
Charged Device Model (All pins, per JEDEC JS-002) <sup>(NOTE3)</sup>	±2kV

NOTE1: All voltage values are with respect to ANODE, unless otherwise noted.

NOTE2: The human body model is a 100pF capacitor discharged through a 1.5kΩ resistor into each pin. Test method: ESDA/JEDEC JS-001-2023.

NOTE3: Test method: ESDA/JEDEC JS-002-2022.

**Recommended Operating Conditions**

PARAMETERS		MIN	MAX	UNIT
$V_{KA}$	Cathode voltage	$V_{REF}$	36	V
$I_{KA}$	Cathode current	1	100	mA
$T_A$	Operating junction temperature $T_A$	-40	125	°C

## Electrical Characteristics

All test conditions:  $T_A = 25^\circ\text{C}$  for typical values (unless otherwise noted).

PARAMETER	TEST CONDITION	MIN	TYP	MAX	UNIT	
$V_{REF}$	Reference voltage	$V_{KA} = V_{REF}, I_{KA} = 10\text{mA}$ , B grade, 0.5% initial accuracy	2.483	2.495	2.507	V
		$V_{KA} = V_{REF}, I_{KA} = 10\text{mA}$ , A grade, 0.8% initial accuracy	2.475	2.495	2.515	V
$V_{DEV}^{(NOTE1)}$	Deviation of reference input voltage over full temperature range	$V_{KA} = V_{REF}, I_{KA} = 10\text{mA}$ ,		5	25	mV
$\left  \frac{\Delta V_{REF}}{\Delta V_{KA}} \right $	Ratio of the change in reference voltage to the change in cathode voltage	$V_{KA} = 10\text{V to } V_{REF}, I_{KA} = 10\text{mA}$		0.1	0.8	mV/V
		$V_{KA} = 36\text{V to } 10\text{V}, I_{KA} = 10\text{mA}$		0.03	0.4	mV/V
$I_{REF}$	Reference input current	$I_{KA} = 10\text{mA}, R_U = 10\text{K}\Omega, R_D$ open		0.2	0.8	$\mu\text{A}$
$I_{DEV}$	Deviation of reference input current over full temperature range	$I_{KA} = 10\text{mA}, R_U = 10\text{K}\Omega, R_D$ open $T_A = -40$ to $125^\circ\text{C}$		0.06	0.8	$\mu\text{A}$
$I_{KA}(\text{MIN})$	Minimum cathode current for regulation	$V_{KA} = V_{REF}$		0.2	0.6	mA
$I_{KA}(\text{OFF})$	Off-state current	$V_{KA} = 36\text{V}, V_{REF} = 0\text{V}$		0.1	0.5	$\mu\text{A}$
$ Z_{KA} ^{(NOTE1)}$	Dynamic output impedance	$V_{KA} = V_{REF}, f \leq 1\text{KHz}$ , $I_{KA} = 1\text{mA to } 100\text{mA}$		0.2		$\Omega$

NOTE1: The relevant data are product design simulation guarantee data, not FT data.

## Typical Characteristics

Ambient temperature is 25°C, unless otherwise noted.

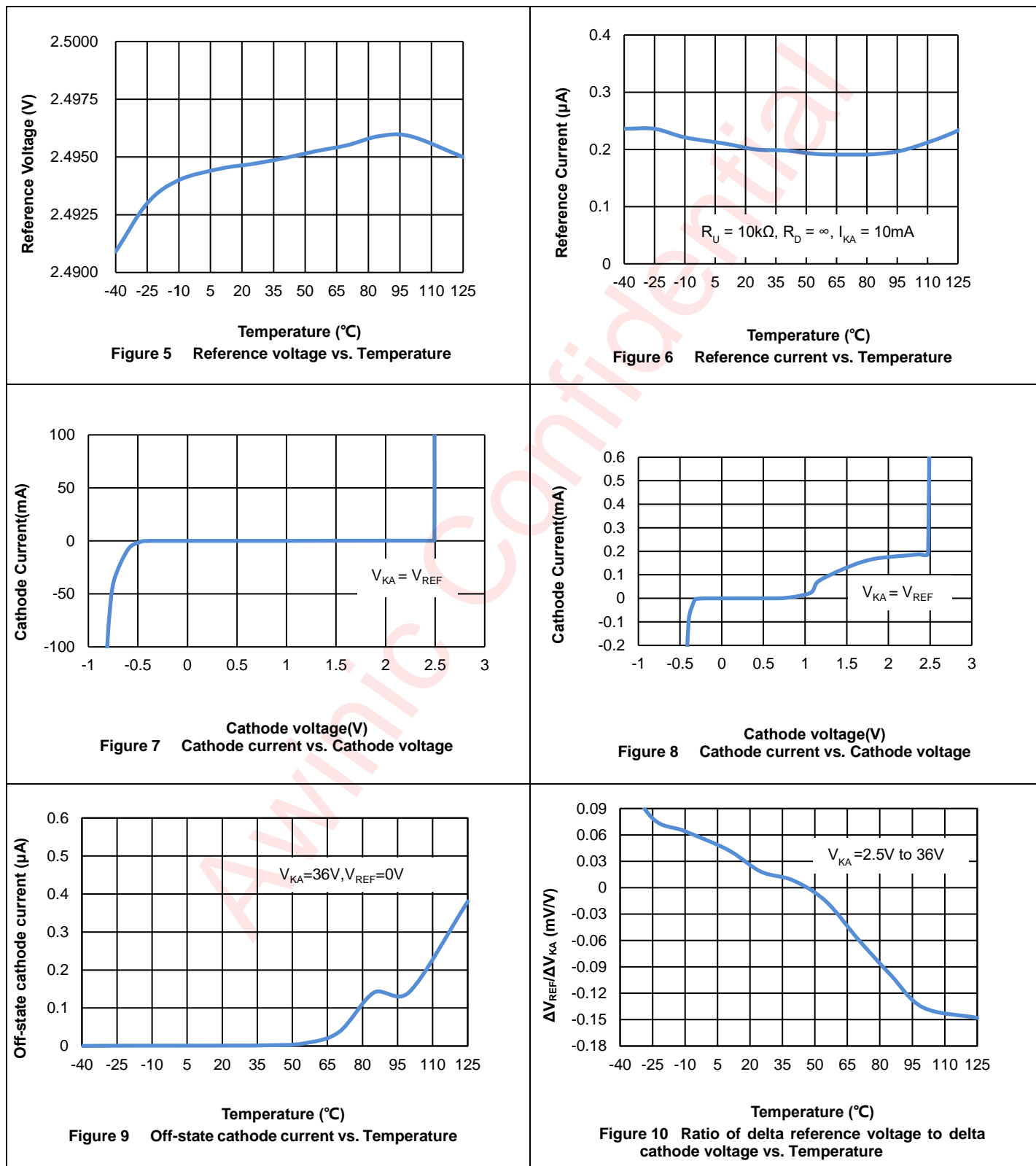

Typical Characteristics(Continued)

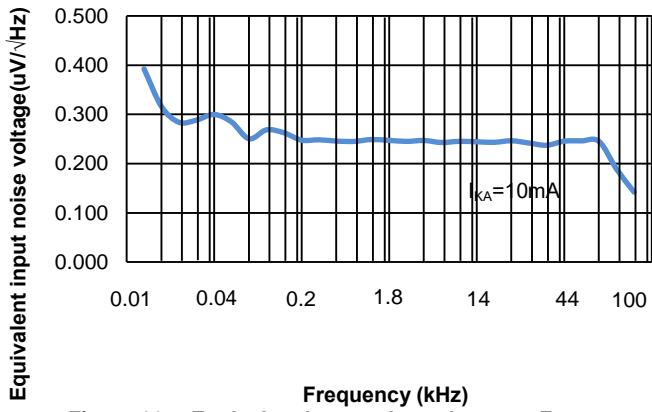

Figure 11 Equivalent input noise voltage vs. Frequency

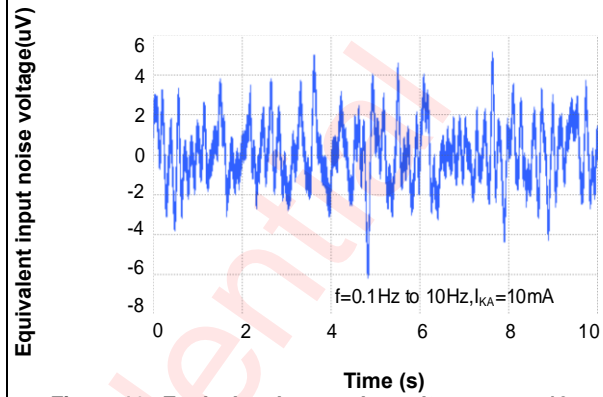

Figure 12 Equivalent input noise voltage over a 10s period

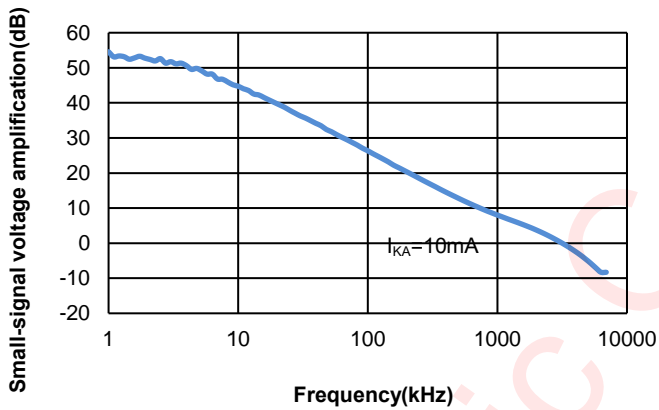

Figure 13 Small-signal voltage amplification vs. Frequency

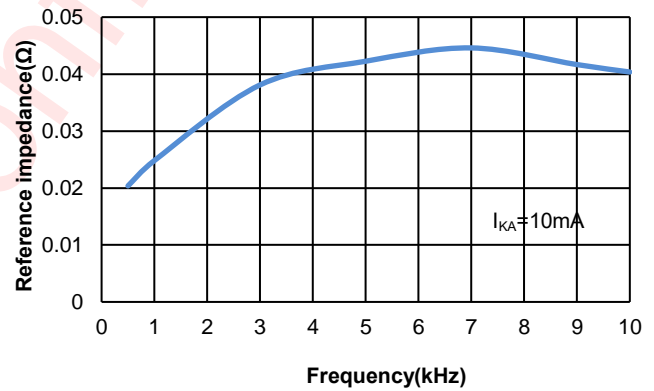

Figure 14 Reference impedance vs. Frequency

## Detailed Functional Description

### Test circuit

#### Typical Characteristics Measurement Information

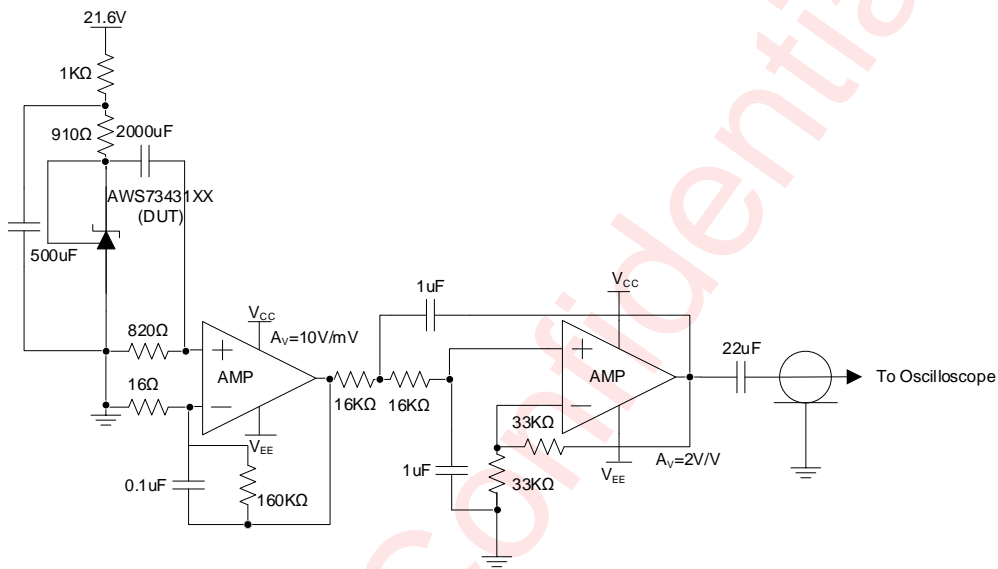

Figure 15 Test circuit for equivalent input noise voltage over a 10s period

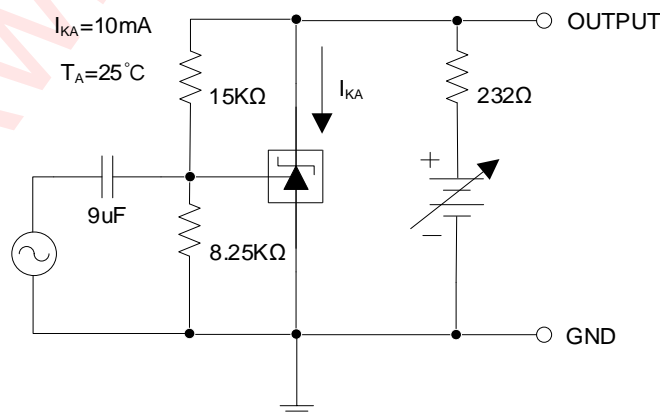

Figure 16 Test circuit for voltage amplification

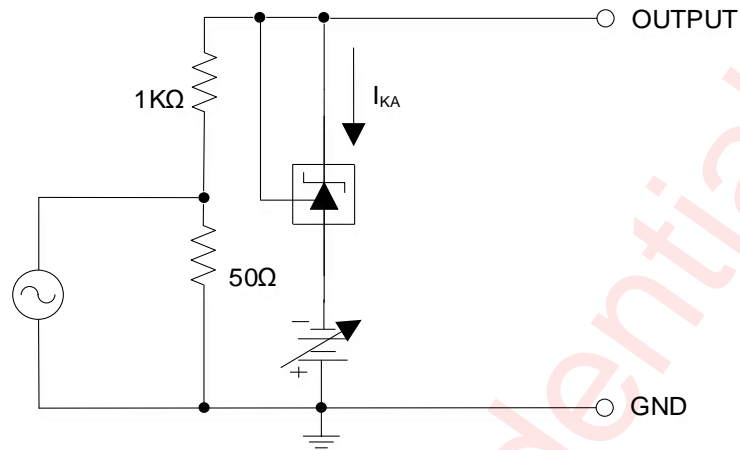

Figure 17 Test circuit for reference impedance

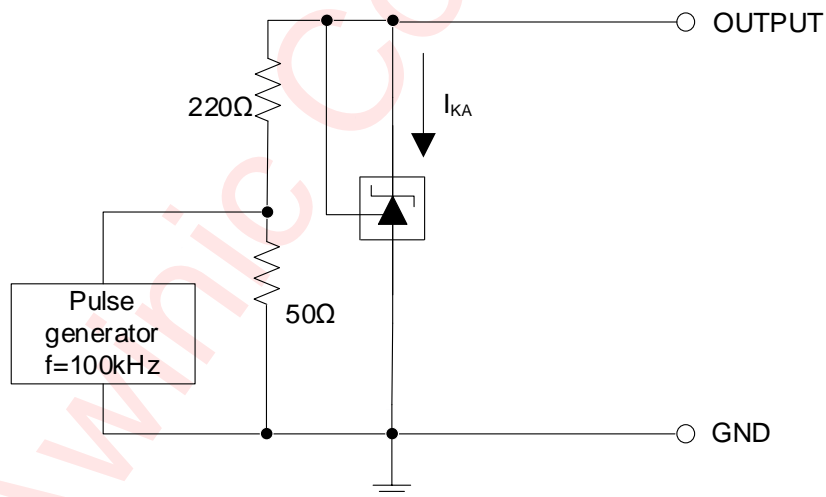

Figure 18 Test circuit for pulse response

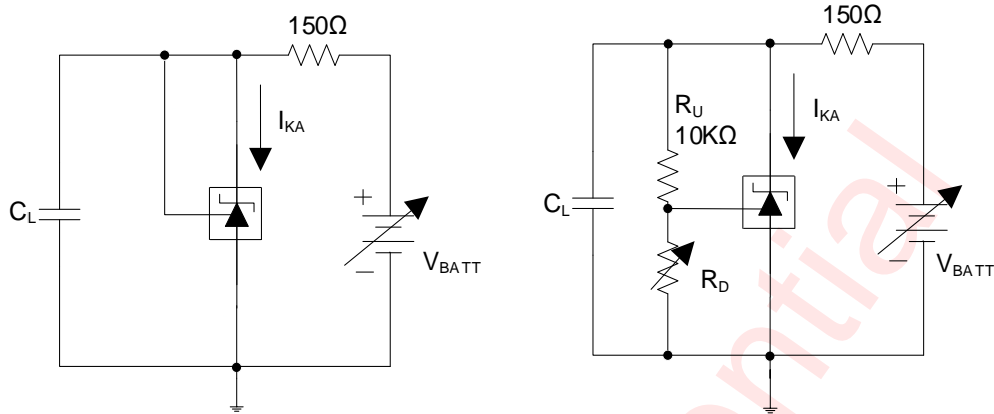

Figure 19 Test circuit for stability boundary conditions

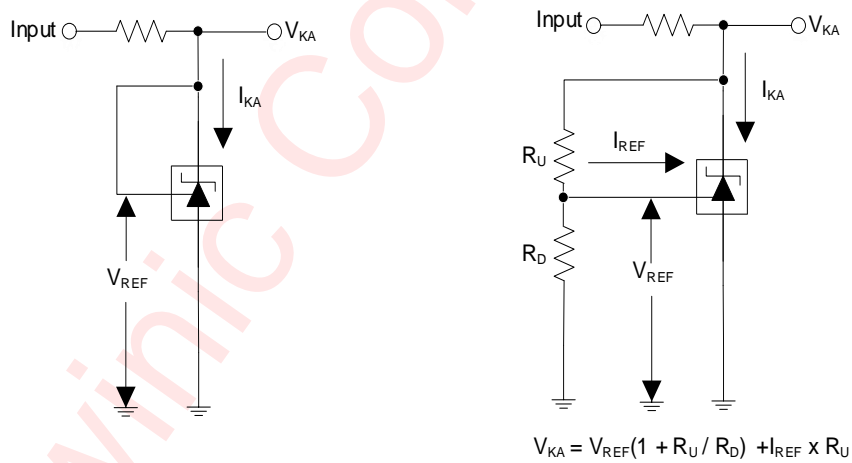

Figure 20 Test circuit for  $V_{KA}=V_{REF}$

Figure 21 Test circuit for  $V_{KA}>V_{REF}$

### Temperature coefficient

The deviation parameters  $V_{DEV}$  and  $I_{DEV}$  are defined as the differences between the maximum and minimum values obtained over the rated temperature range. The average full-range temperature coefficient of the reference input voltage  $\alpha V_{REF}$  is defined as:

$$|\alpha V_{REF}| \left( \frac{\text{ppm}}{^{\circ}\text{C}} \right) = \frac{\left( \frac{V_{DEV}}{V_{REF \text{ at } 25^{\circ}\text{C}}} \right) \times 10^6}{\Delta T_A}$$

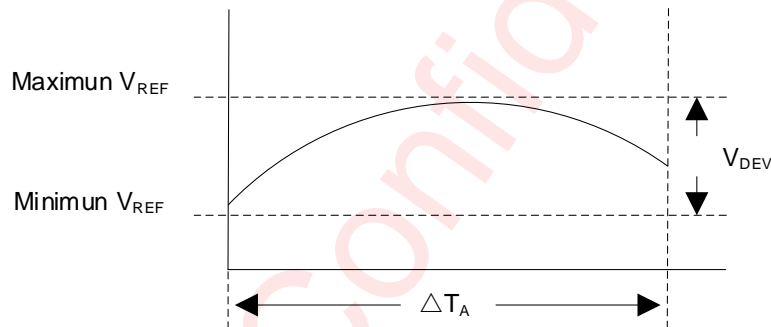

where,

$\Delta T_A$  is the rated operating temperature range of the device.

$\alpha V_{REF}$  is positive or negative, depending on whether minimum  $V_{REF}$  or maximum  $V_{REF}$ , respectively, occurs at the lower temperature.

### Dynamic impedance

The dynamic impedance is defined as:

$$|z_{KA}| = \frac{\Delta V_{KA}}{\Delta I_{KA}}$$

When the device is operating with two external resistors, the total dynamic impedance of the circuit is given by:

$$|z'| = \frac{\Delta V}{\Delta I}$$

which is approximately equal to

$$|z_{KA}| \left( 1 + \frac{R_U}{R_D} \right)$$

## Application Information

### Shunt Regulator/Reference

The Figure 21 is shunt regulator schematic, design requirements for this design example, use the parameters listed in Table 1 as the input parameters.

**Table 1. Design parameters**

Design parameter	Example value
Supply voltage <sup>(NOTE1)</sup>	40V
Cathode current (I <sub>KA</sub> )	5mA
Output voltage(V <sub>OUT</sub> )	V <sub>REF</sub> to 36V
Load capacitance	100nF
Feedback resistor values and accuracy R <sub>U</sub> and R <sub>D</sub>	10kΩ (0.1%)

Note1: All voltage values are with respect to ANODE, unless otherwise noted.

### Detailed design procedure

When using the AWS7343XXX as a shunt regulator, determine the following:

- Input voltage range
- Temperature range
- Total accuracy
- Cathode current
- Reference initial accuracy
- Output capacitance

### Programming Output/Cathode Voltage

In order to program the cathode voltage to a regulated voltage a resistive divider must be shunted between the CATHODE and ANODE pins with the mid-point tied to the REF pin. This can be seen in Figure 21, with R<sub>U</sub> and R<sub>D</sub> being the resistive divider. The cathode/output voltage in the shunt regulator configuration can be approximated by the equation shown in Figure 21. The cathode voltage can be more accurately determined by taking into account the reference input current:

$$V_{OUT}=V_{REF} \left(1+\frac{R_U}{R_D}\right)+I_{REF} \times R_U$$

In order for this equation to be valid, the AWS7343XXX must be fully biased so that it has enough open-loop gain to mitigate any gain error. This can be done by meeting the I<sub>MIN</sub> specification denoted in electrical characteristics.

**Total Accuracy**

When programming the output above unity gain ( $V_{KA} = V_{REF}$ ), the AWS7343XXX is susceptible to other errors that may affect the overall accuracy beyond  $V_{REF}$ . These errors include:

- $R_U$  and  $R_D$  accuracies
- $V_{(DEV)}$ : change in reference voltage over temperature
- $\Delta V_{REF}/\Delta V_{KA}$ : change in reference voltage to the change in cathode voltage
- $|Z_{KA}|$ : dynamic impedance, causing a change in cathode voltage with cathode current

Worst case cathode voltage can be determined by taking all of the variables into account.

**Power Supply Recommendations**

When using the AWS7343XXX as a linear regulator to supply a load, designers will typically use a bypass capacitor on the CATHODE pin. When doing this, the AWS7343XXX remains stable.

In order to not exceed the maximum cathode current, be sure that the supply voltage is current limited. Also, be sure to limit the current being driven into the REF pin, as not to exceed its absolute maximum rating.

For applications shunting high currents, pay attention to the cathode and anode trace lengths, adjusting the width of the traces to have the proper current density.

## Tape And Reel Information

### SOT23-3L (AWS73431XX)

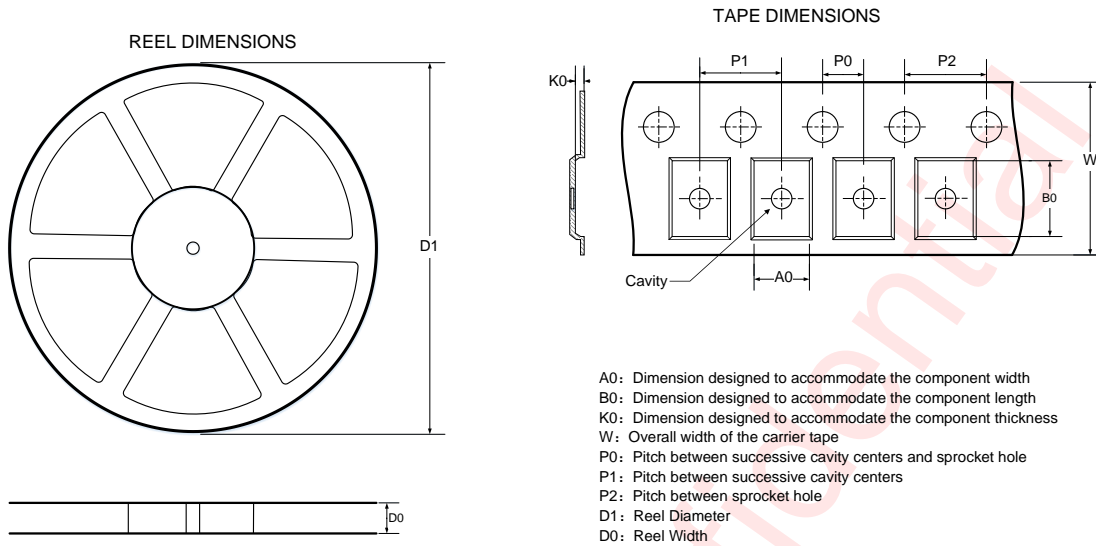

#### QUADRANT ASSIGNMENTS FOR PIN 1 ORIENTATION IN TAPE

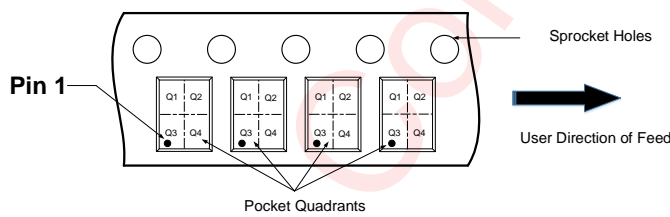

Note: The above picture is for reference only. Please refer to the value in the table below for the actual size

#### DIMENSIONS AND PIN1 ORIENTATION

D1 (mm)	D0 (mm)	A0 (mm)	B0 (mm)	K0 (mm)	P0 (mm)	P1 (mm)	P2 (mm)	W (mm)	Pin1 Quadrant
178	8.4	3.15	2.77	1.22	2	4	4	8	Q3

All dimensions are nominal

SOT23-5L

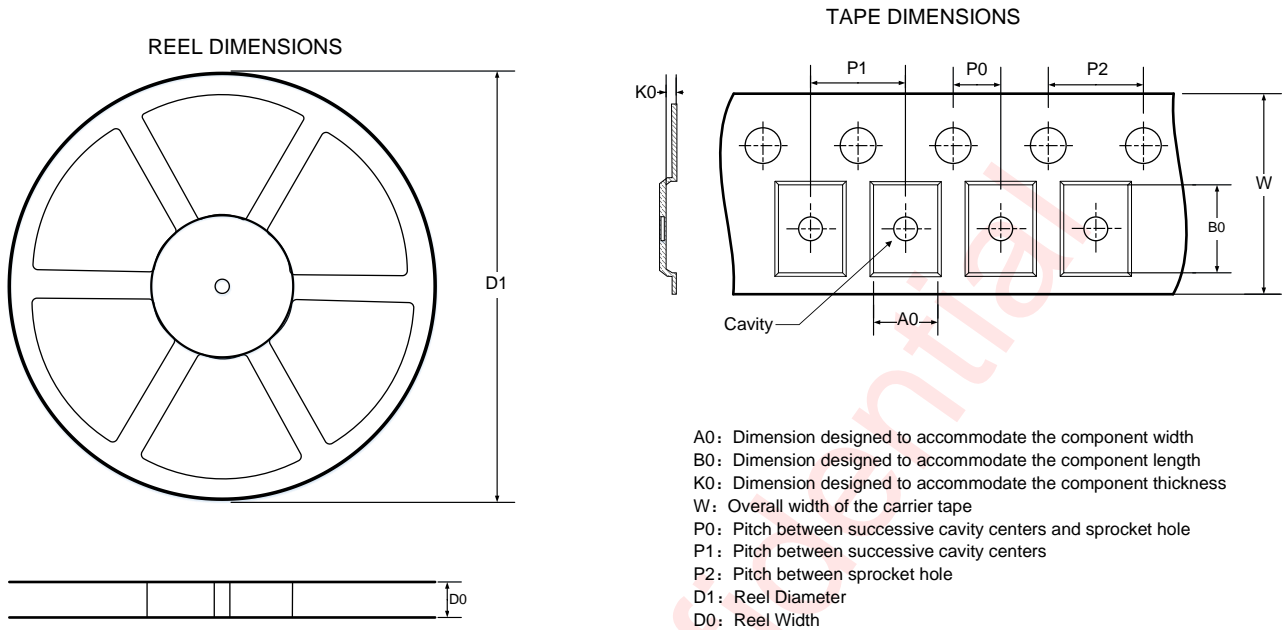

QUADRANT ASSIGNMENTS FOR PIN 1 ORIENTATION IN TAPE

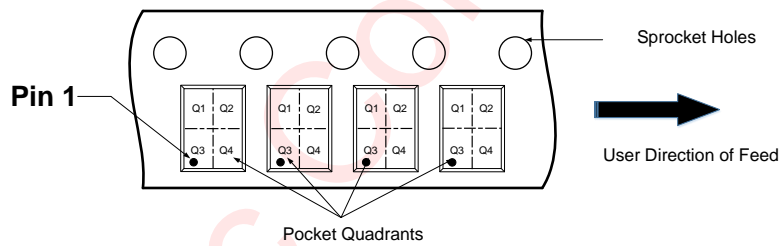

Note: The above picture is for reference only. Please refer to the value in the table below for the actual size

DIMENSIONS AND PIN1 ORIENTATION

D1 (mm)	D0 (mm)	A0 (mm)	B0 (mm)	K0 (mm)	P0 (mm)	P1 (mm)	P2 (mm)	W (mm)	Pin1 Quadrant
178.00	8.50	3.23	3.17	1.37	2.00	4.00	4.00	8.00	Q3

All dimensions are nominal

## Package Description

### SOT23-3L(AWS73431XX)

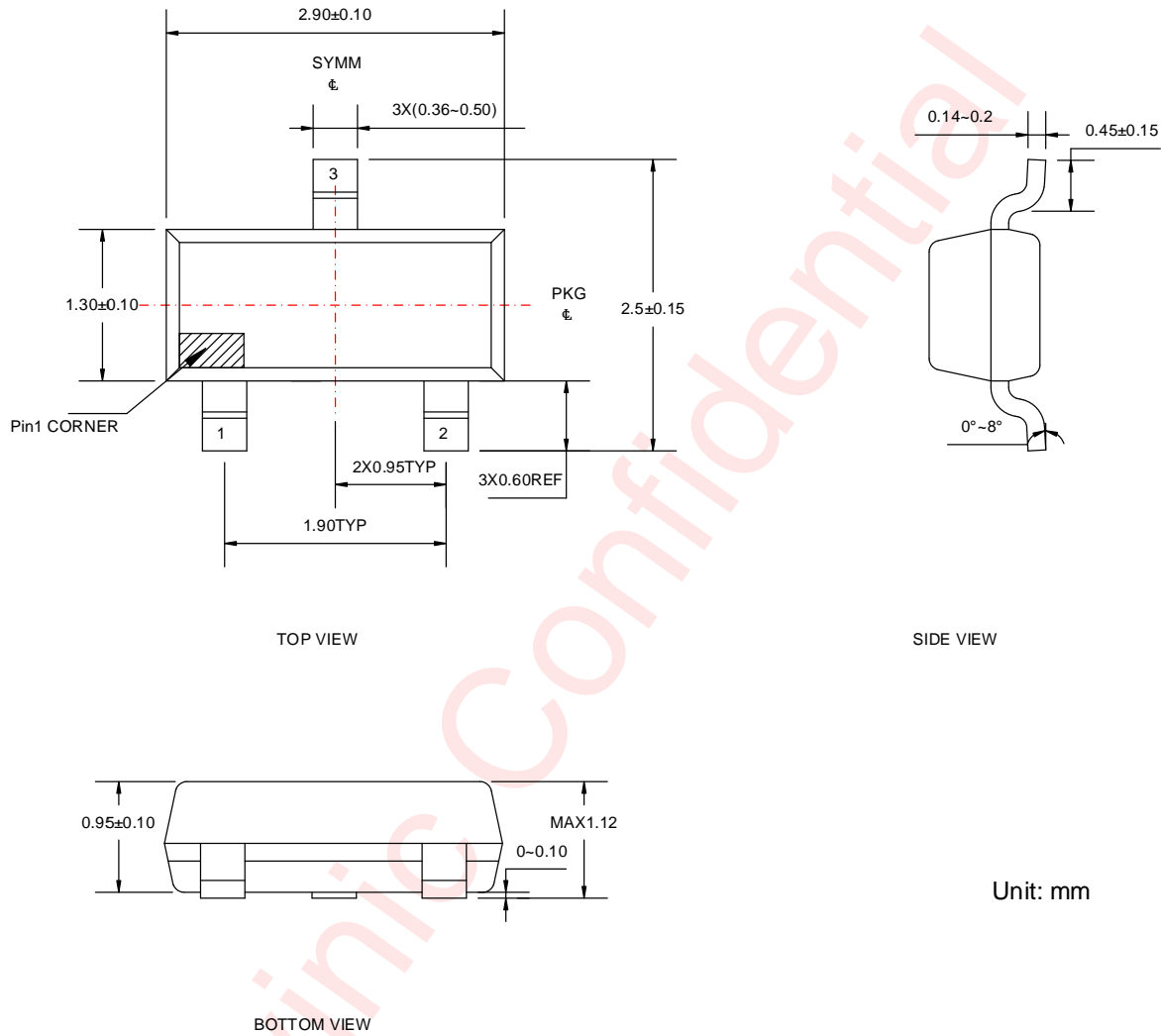

Unit: mm

SOT23-5L

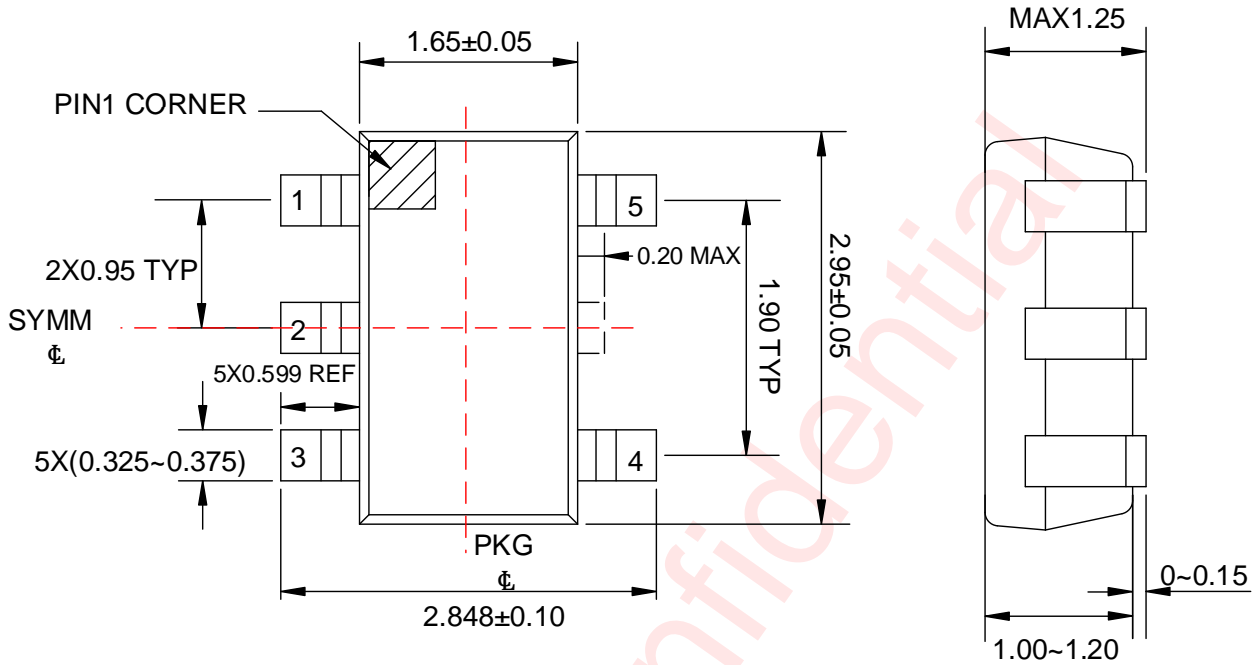

Top View

Side View

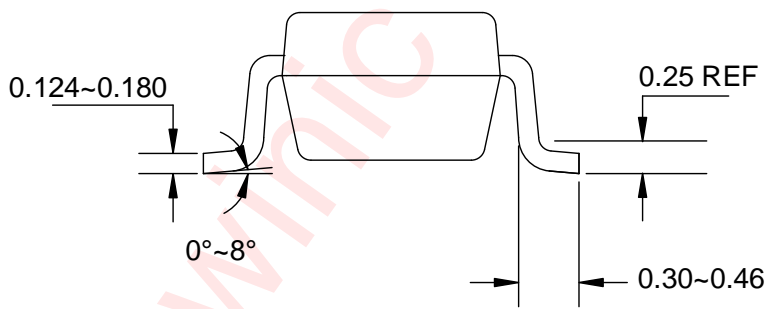

Side View

Unit: mm

Land Pattern Data

SOT23-3L (AWS73431XX)

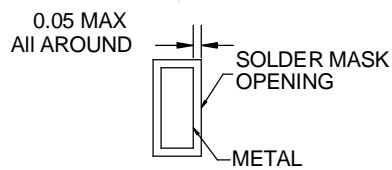
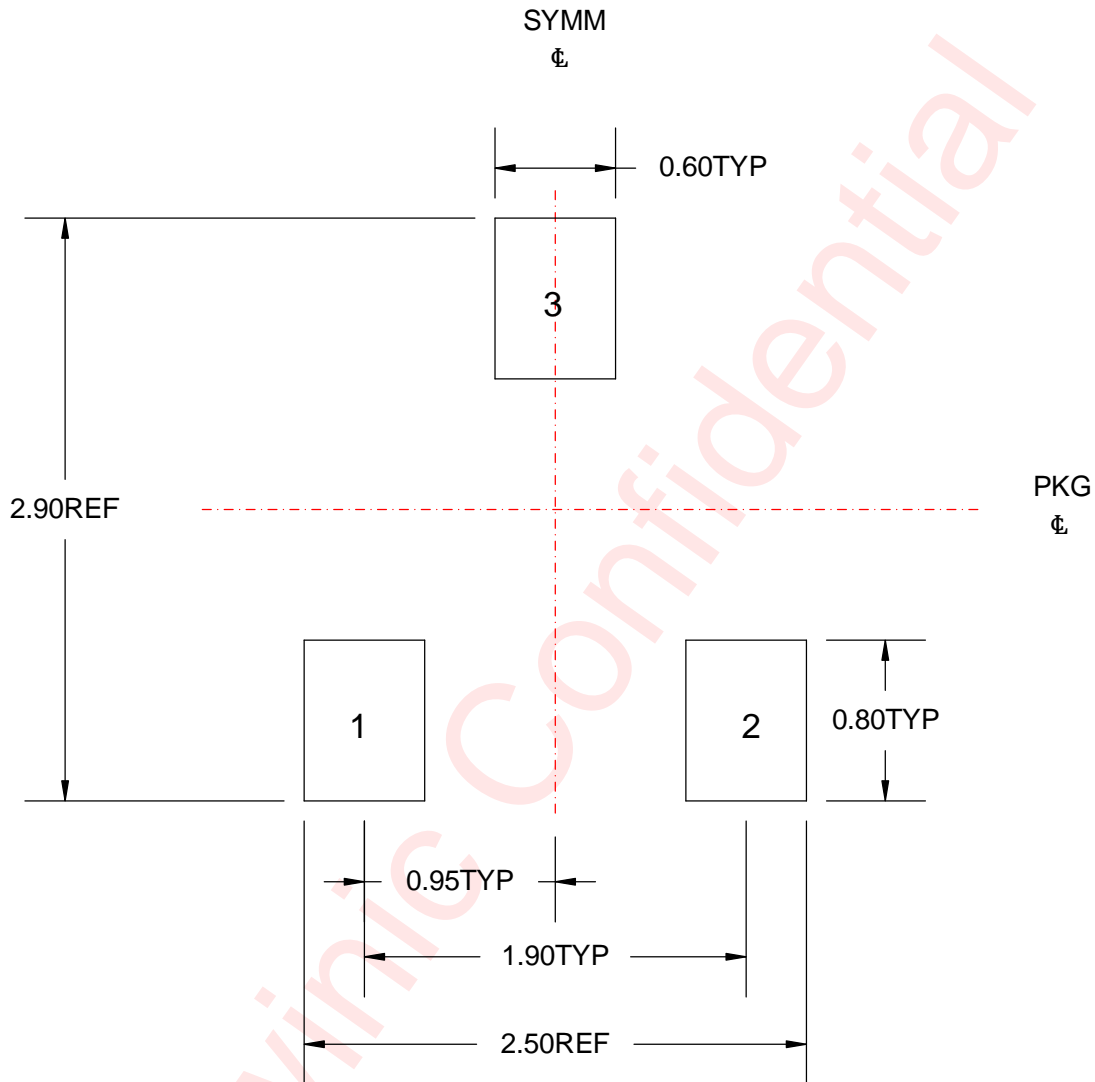

NON SOLDER MASK DEFINED

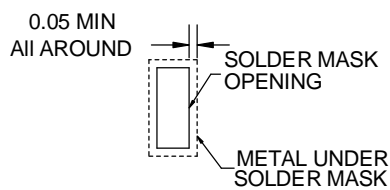

SOLDER MASK DEFINED

Unit: mm

SOT23-5L

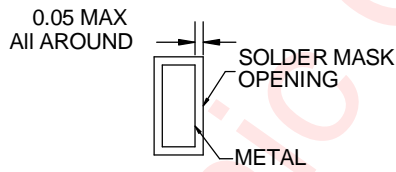
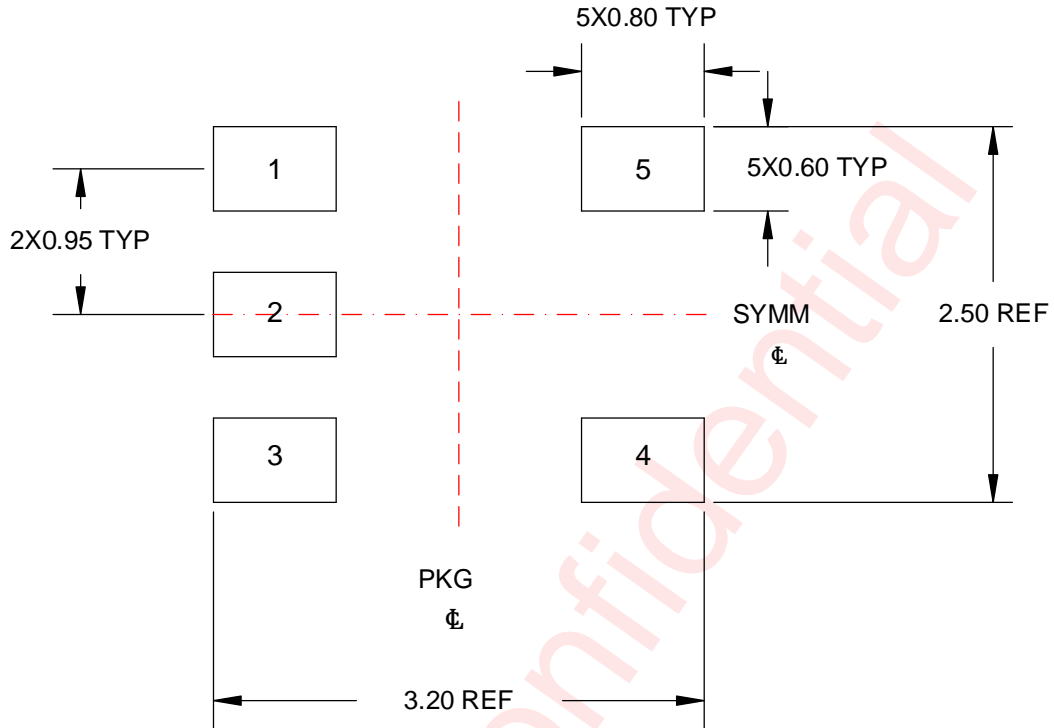

NON SOLDER MASK DEFINED

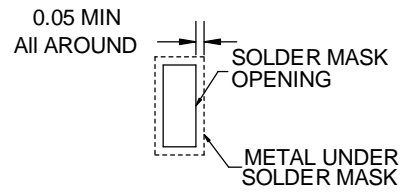

SOLDER MASK DEFINED

Unit: mm

## Revision History

Version	Date	Change Record
V1.0	Jul. 2025	Brief Datasheet V1.0 released

Awinic Confidential

## Disclaimer

Information in this document is believed to be accurate and reliable. However, Shanghai AWINIC Technology Co., Ltd (AWINIC Technology) does not give any representations or warranties, expressed or implied, as to the accuracy or completeness of such information and shall have no liability for the consequences of use of such information.

AWINIC Technology reserves the right to make changes to information published in this document, including without limitation specifications and product descriptions, at any time and without notice. Customers shall obtain the latest relevant information before placing orders and shall verify that such information is current and complete. This document supersedes and replaces all information supplied prior to the publication hereof.

AWINIC Technology products are not designed, authorized or warranted to be suitable for use in medical, military, aircraft, space or life support equipment, nor in applications where failure or malfunction of an AWINIC Technology product can reasonably be expected to result in personal injury, death or severe property or environmental damage. AWINIC Technology accepts no liability for inclusion and/or use of AWINIC Technology products in such equipment or applications and therefore such inclusion and/or use is at the customer's own risk.

Applications that are described herein for any of these products are for illustrative purposes only. AWINIC Technology makes no representation or warranty that such applications will be suitable for the specified use without further testing or modification.

All products are sold subject to the general terms and conditions of commercial sale supplied at the time of order acknowledgement.

Nothing in this document may be interpreted or construed as an offer to sell products that is open for acceptance or the grant, conveyance or implication of any license under any copyrights, patents or other industrial or intellectual property rights.

Reproduction of AWINIC information in AWINIC data books or data sheets is permissible only if reproduction is without alteration and is accompanied by all associated warranties, conditions, limitations, and notices. AWINIC is not responsible or liable for such altered documentation. Information of third parties may be subject to additional restrictions.

Resale of AWINIC components or services with statements different from or beyond the parameters stated by AWINIC for that component or service voids all express and any implied warranties for the associated AWINIC component or service and is an unfair and deceptive business practice. AWINIC is not responsible or liable for any such statements.