

FM Low-Noise-Amplifier in Alliance with Internal Antenna

FEATURES

- Without any earphone or telescopic antenna, receive FM radio signal through re-using other antenna
- Ultra-low noise figure: 1.2dB
- Standard CMOS process technology
- High power gain of 21dB under 2.8V supply
- High linearity P1dB: -21dBm
- Supply voltage: 1.5V~3.6V
- Shutdown current: <math><0.1\mu\text{A}</math>
- Compact DFN 1.5mmX1.0mmX0.55mm-6L package
- Operation frequency: 64MHz-110MHz

APPLICATIONS

- Feature or smart phone
- Portable audio device

TYPICAL APPLICATION CIRCUIT

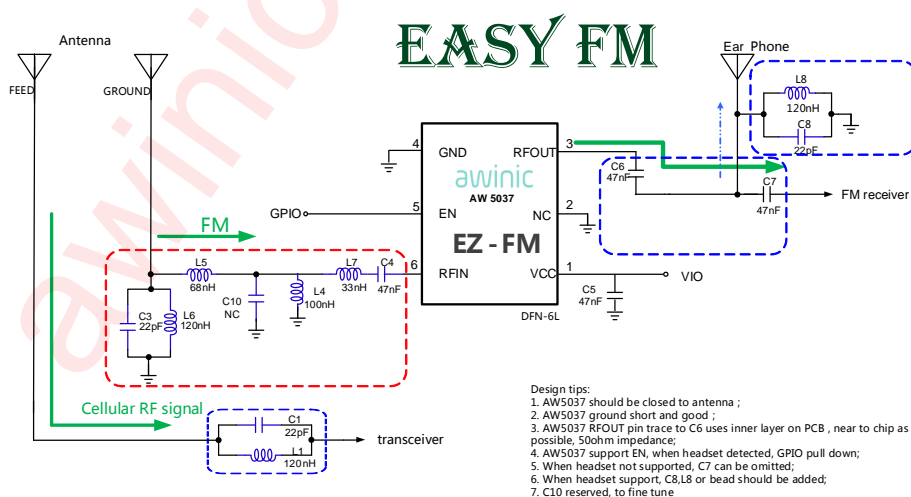

Figure 1 Typical Application Circuit of AW5037

PIN CONFIGURATION AND TOP MARK

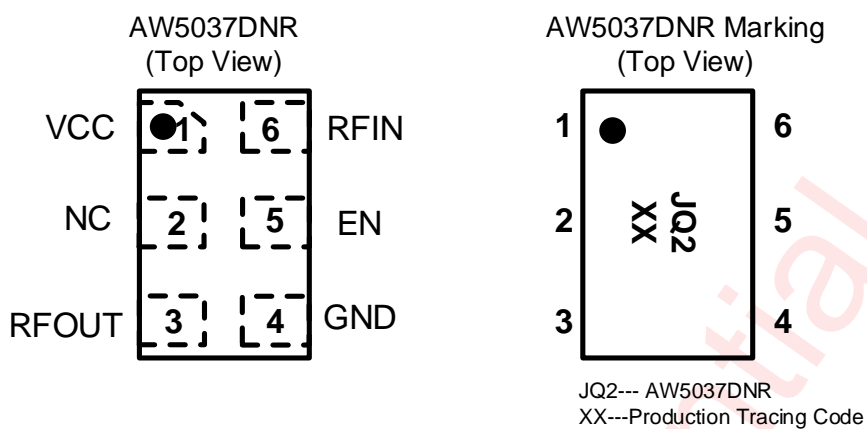

Figure 2 Pin Configuration and Top Mark

PIN DEFINITION

No.	NAME	DESCRIPTION
1	VCC	Supply connection.
2	NC	Not connected. Prefer ground.
3	RFOUT	RF output.
4	GND	Ground.
5	EN	EN (high level) supports 1.8V/2.8V IO with pull-down function.
6	RFIN	RF input.

FUNCTIONAL BLOCK DIAGRAM

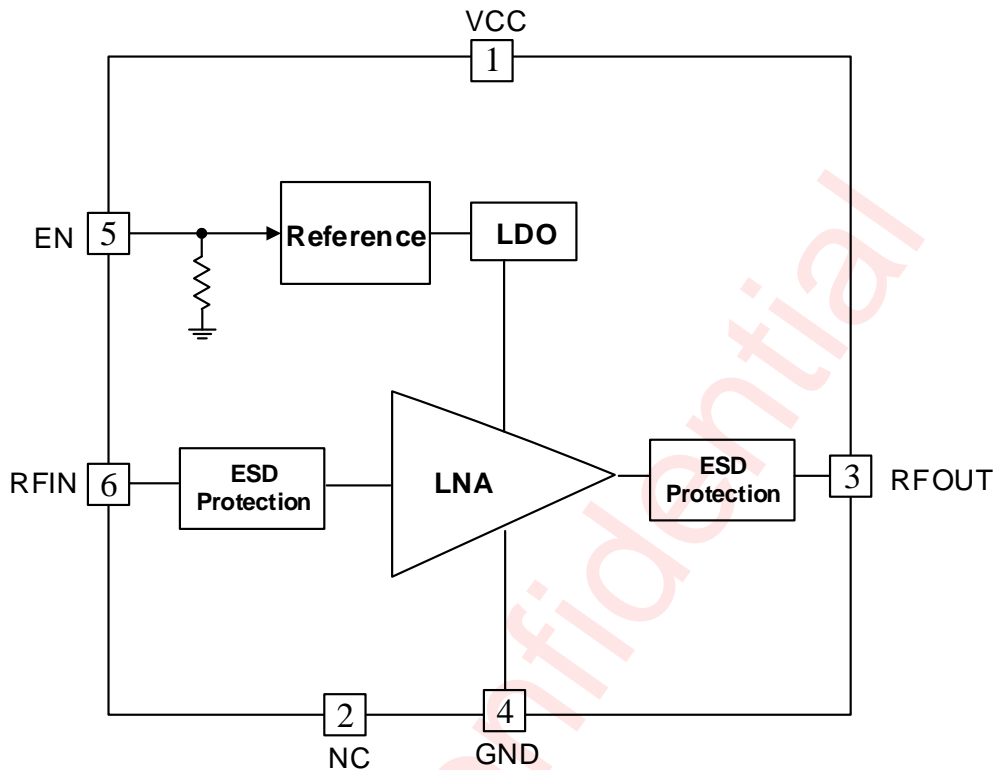

Figure 3 Function Block Diagram

ORDERING INFORMATION

Part Number	Temperature	Package	Marking	Moisture Sensitivity Level	Environmental Information	Delivery Form
AW5037 DNR	-40°C~85°C	DFN 1.5mmX1.0 mm -6L	JQ2	MSL1	ROHS+HF	3000 units/Tape and Reel

ABSOLUTE MAXIMUM RATINGS (NOTE1)

PARAMETERS	RANGE
Supply voltage VCC	-0.3V to 4.2V
EN pin voltage	-0.3V to 4.2V
Supply maximum current ICC	30mA
RF input power Pin	20dBm
Maximum Junction temperature T _{JMAX}	125°C
Storage temperature T _{STG}	-65°C to 150°C
Operating free-air temperature range	-40°C to 85°C
Lead temperature (Soldering 10 Seconds)	260°C
Junction-to-ambient thermal resistance θ_{JA}	178°C/W
ESD(NOTE 2)	
HBM	±2kV
CDM	±1.5kV
Latch-up	
JEDEC STANDARD NO.78E SEPTEMBER 2016	+IT: 200mA -IT: -200mA

ELECTRICAL CHARACTERISTICS

TA=25°C, VCC=1.8V, EN=1.8V, Rs=Ro=50ohm, typical values (unless otherwise noted).

	Parameter	Test Condition	Min	Typ	Max	Units
Freq	Frequency	-	64	90	110	MHz
ISD	Shut-down Current	EN=0V		0.1	1	μA
IQ	Static Current	EN=1.8V	6.0	9	12	mA
IEN	EN pin current	EN=1.8V		0.3	1	uA
NF	Noise Figure	Input/Output 50ohm		1.4	1.7	dB
S11	Input Return Loss	Input/Output 50ohm	-5.5	-3.8	-1.5	dB
S12	Reverse Isolation	Input/Output 50ohm	-50	-39.0	-30	dB
S21	Power Gain	Input/Output 50ohm	16.5	20.0		dB
S22	Output Return Loss	Input/Output 50ohm	-30	-20.5	-15	dB
Kf	Stability Factor	1MHz-3000MHz	1			
IIP3	Input 3rd-order intercept point	(NOTE 3)	-18	-15		dBm
IB P-1dB	In-Band 1dB-compression point	Input/Output 50ohm	-27	-23		dBm
OOB P-1dB	Output-Of-Band 1dB- compression point	(NOTE 4)	-18	-12		dBm
ton	Turn-on time	time from EN ON to 90% of the gain		120	250	us
toff	Turn-off time	time from EN OFF to 10% of the gain			1	us
AM-PM		Input power -40dBm~-20dBm		1.8	3.0	deg
Stability	Input or Output Load VSWR Stability	Input VSWR=12:1, Output VSWR=6:1; all phase angles, input power=-40dBm			-40	dBm
Ruggedness	Input load VSWR Ruggedness	Input VSWR=10:1, all phase angles, step 15°, 10 seconds for each step	No damage or permanent degradation to device			-

TA=25°C, VCC=2.8V, EN=2.8V, Rs=Ro=50ohm, typical values (unless otherwise noted).

	Parameter	Test Condition	Min	Typ	Max	Units
Freq	Frequency	-	64	90	110	MHz
ISD	Shut-down Current	EN=0V		0.1	1.0	μA
IQ	Static Current	EN=2.8V	8.0	11	14	mA
IEN	EN pin current	EN=2.8V		0.9	2	uA
NF	Noise Figure	Input/Output 50ohm		1.2	1.5	dB
S11	Input Return Loss	Input/Output 50ohm	-5.5	-3.9	-1.5	dB
S12	Reverse Isolation	Input/Output 50ohm	-50	-37.3	-30	dB
S21	Power Gain	Input/Output 50ohm	17.5	21.0		dB
S22	Output Return Loss	Input/Output 50ohm	-30	-18.0	-15.0	dB
Kf	Stability Factor	1MHz-3000MHz	1			
IIP3	Input 3rd-order intercept point	(NOTE 3)	-15.0	-11.5		dBm
IB P-1dB	In-Band 1dB-compression point	Input/Output 50ohm	-25.0	-21.0		dBm
OOB P-1dB	Output-Of-Band 1dB- compression point	(NOTE 4)	-15.0	-9.0		dBm
ton	Turn-on time	time from EN ON to 90% of the gain		80	200	us
toff	Turn-off time	time from EN OFF to 10% of the gain			1	us
AM-PM		Input power -40dBm~-20dBm		2.1	3.0	deg
Stability	Input or Output Load VSWR Stability	Input VSWR=12:1, Output VSWR=6:1; all phase angles, input power=-40dBm			-40	dBm
Ruggedness	Input load VSWR Ruggedness	Input VSWR=10:1, all phase angles, step 15°, 10 seconds for each step	No damage or permanent degradation to device			-

NOTE1: Conditions out of those ranges listed in "absolute maximum ratings" may cause permanent damages to the device. In spite of the limits above, functional operation conditions of the device should within the ranges listed in "recommended operating conditions". Exposure to absolute-maximum-rated conditions for prolonged periods may affect device reliability.

NOTE2: The human body model is a 100pF capacitor discharged through a 1.5kΩ resistor into each pin. Test method: MIL-STD-883J Method 3015.9. The CDM could refer to JEDEC EIA/JESD22-C101F

NOTE3: Measure IIP3 parameter through two tones of -40dBm/tone with the frequency of 97MHz and 98MHz

NOTE4: Input/Output are both 50ohm. Input signal is composed of in-band 90MHz signal and out-of-band 900MHz signal. Signal of 90MHz is fixed to -40dBm; signal of 900MHz varies and power level is measured when power gain of 90MHz signal drops 1dB.

TYPICAL CHARACTERISTICS

Test condition: TA=25°C, VCC=1.8V, EN=1.8V, Rs=Ro=50ohm, frequency=90 MHz for typical values (Unless otherwise noted)

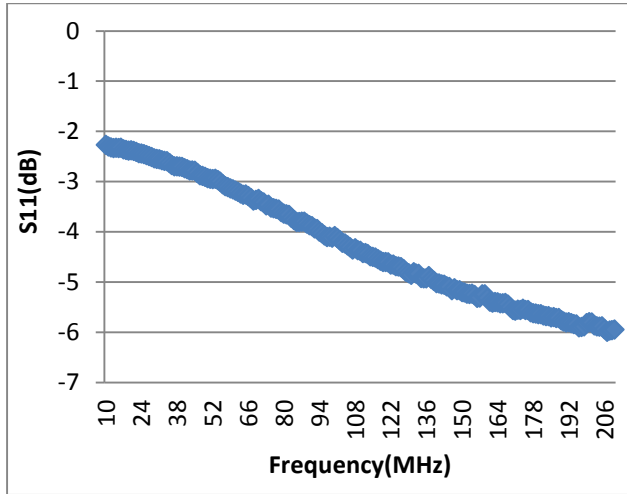

Input Return Loss(S11)

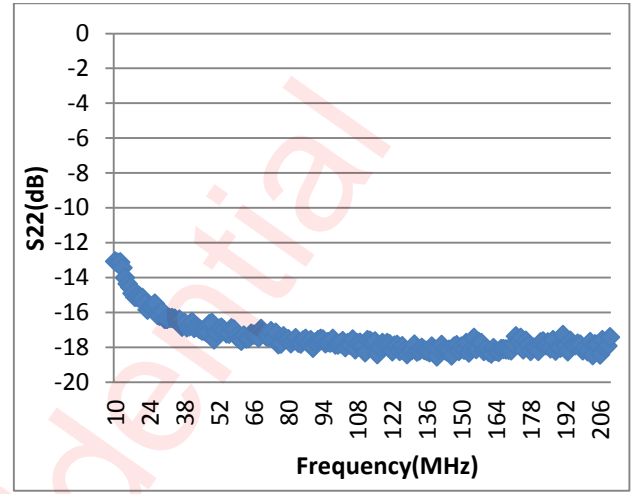

Output Return Loss(S22)

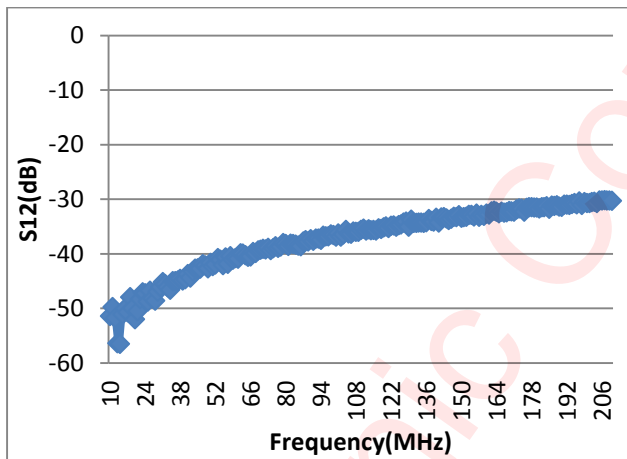

Reverse Isolation(S12)

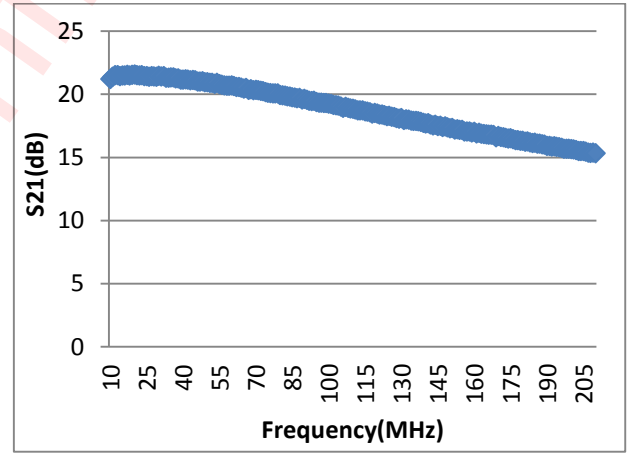

Power Gain(S21)

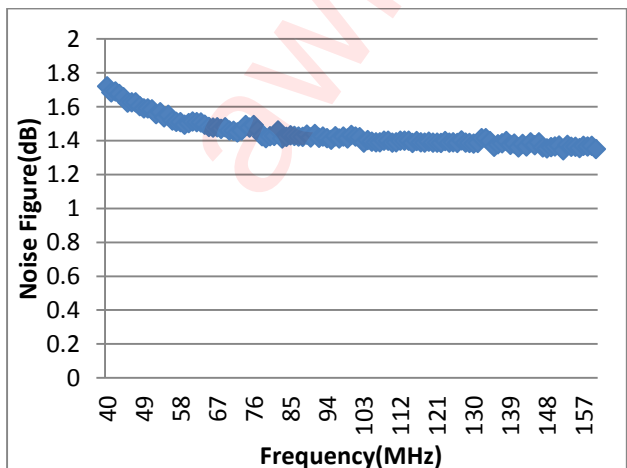

Noise Figure(NF)

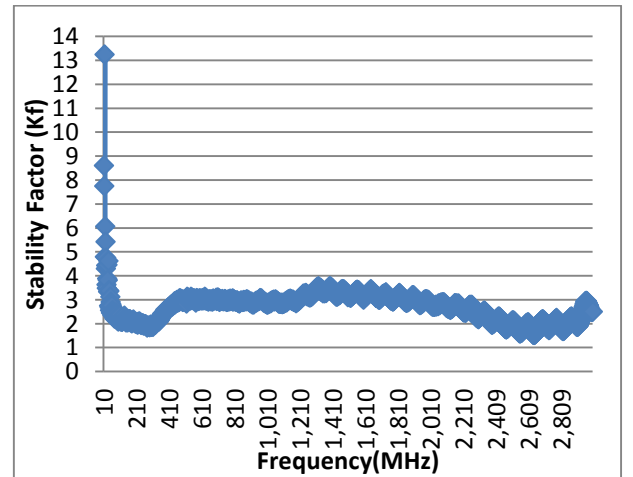

Stability Factor(Kf)

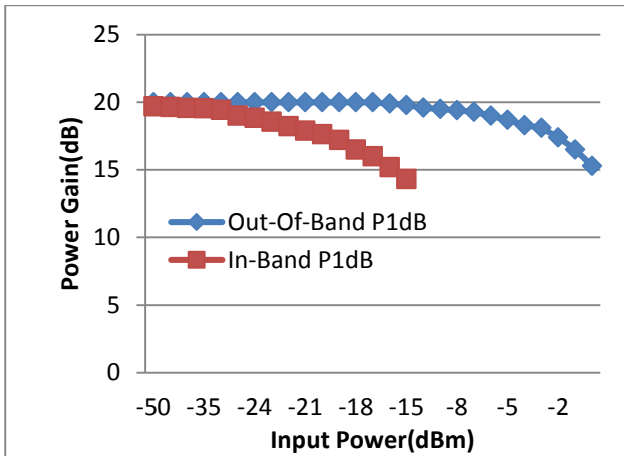

P1dB(In-Band/Out-of-Band)

Test condition: TA=25°C, VCC=2.8V, EN=2.8V, Rs=Ro=50ohm, frequency=90MHz for typical values (Unless otherwise noted).

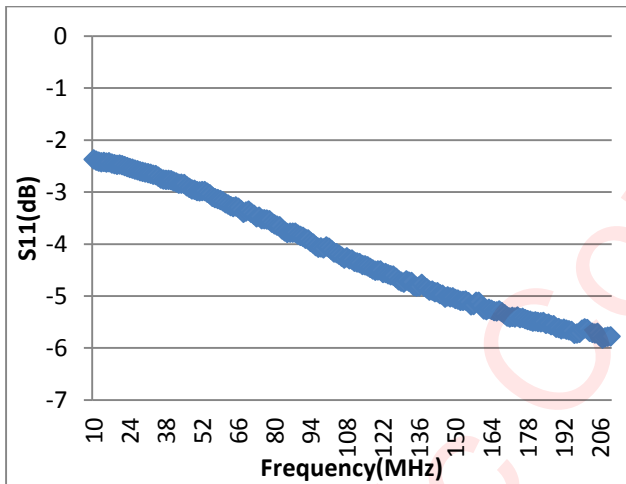

Input Return Loss(S11)

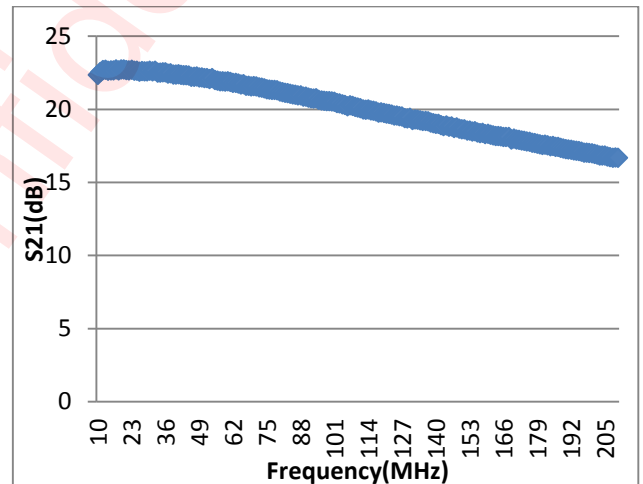

Power Gain(S21)

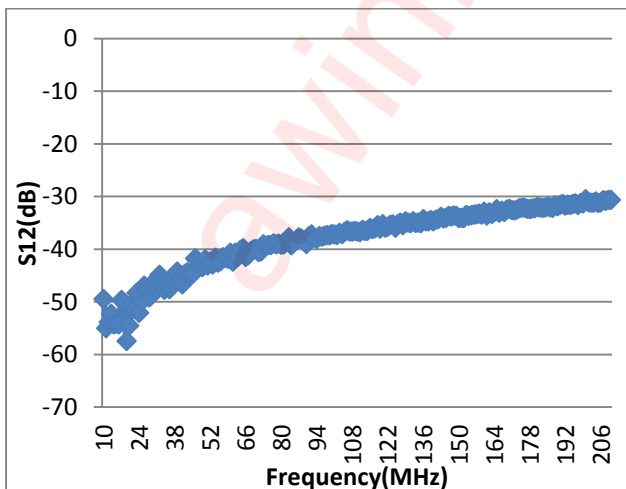

Reverse Isolation(S12)

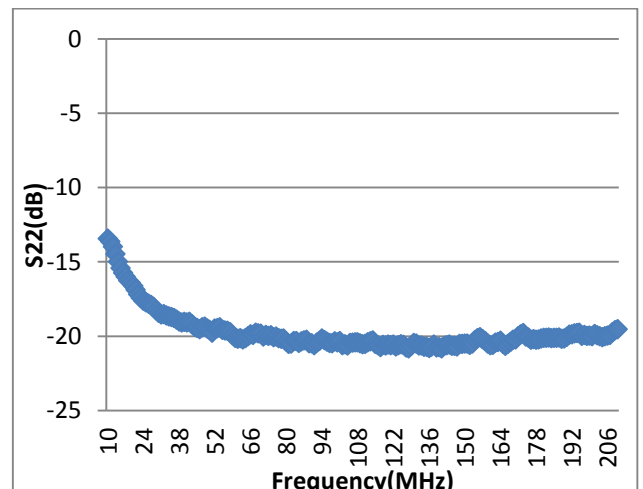

Output Return Loss(S22)

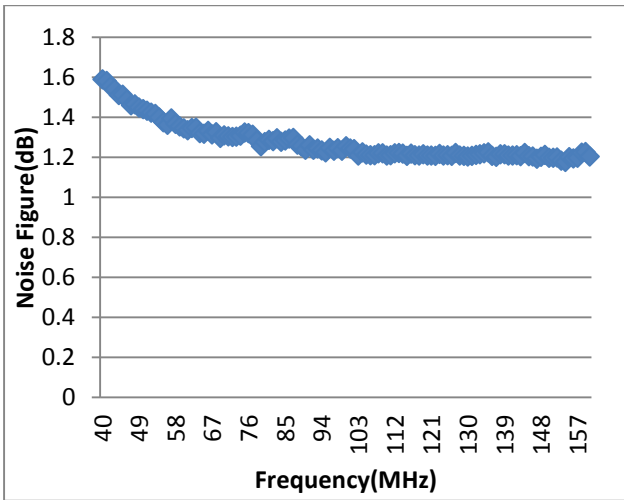

Noise Figure(NF)

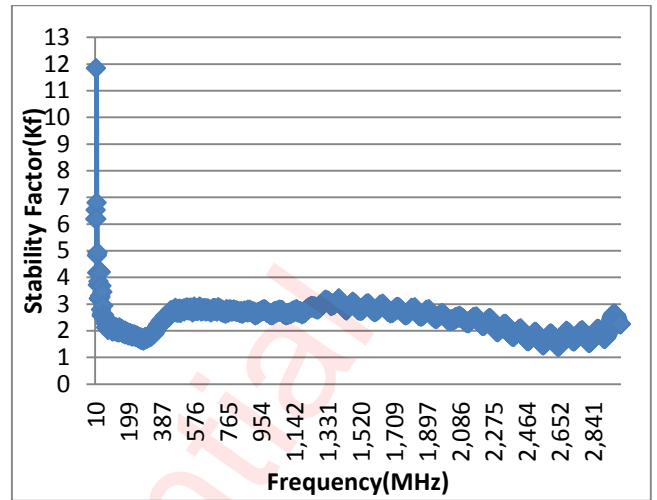

Stability Factor(Kf)

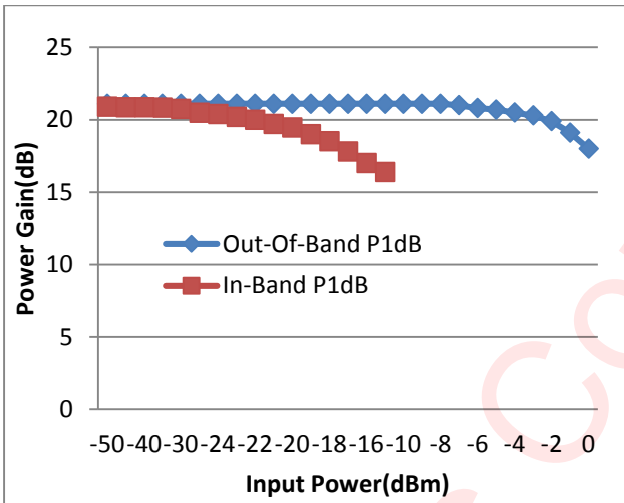

P1dB(In-Band/Out-of-Band)

AW5037 APPLICATION BOARD

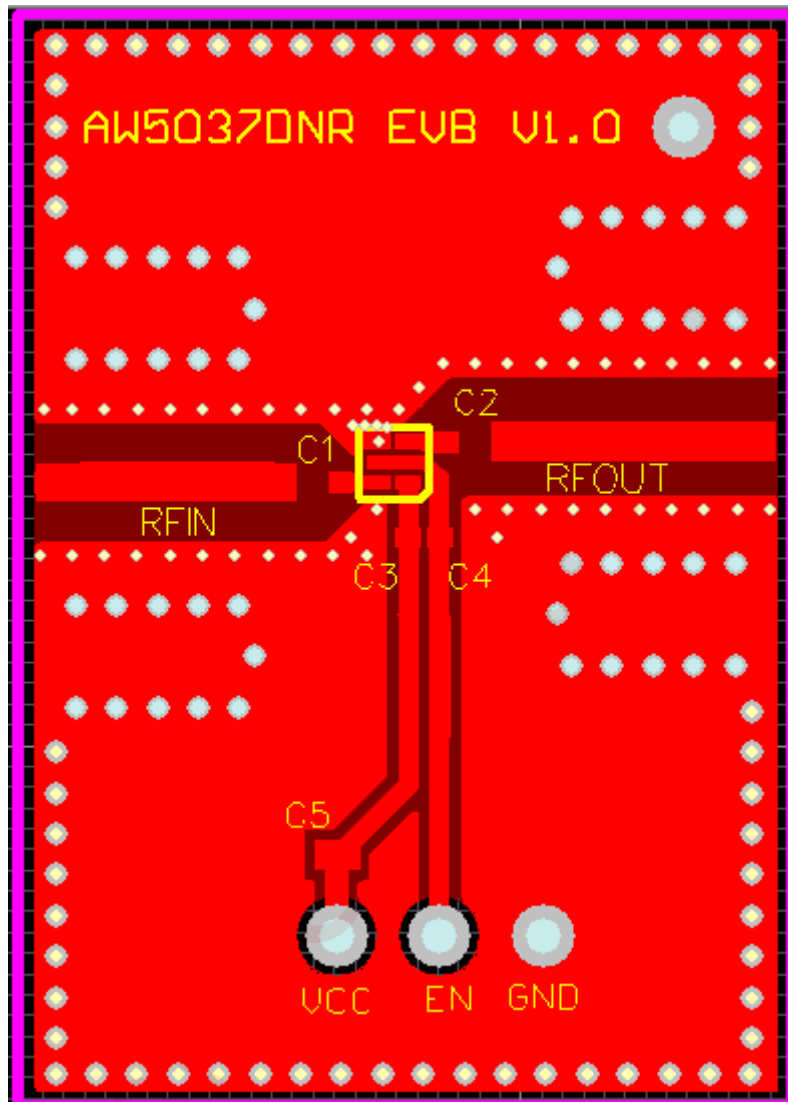

Figure 4 AW5037 EVB

MEASUREMENT DIAGRAM

Test DC Characteristics (Current & Power Consumption)

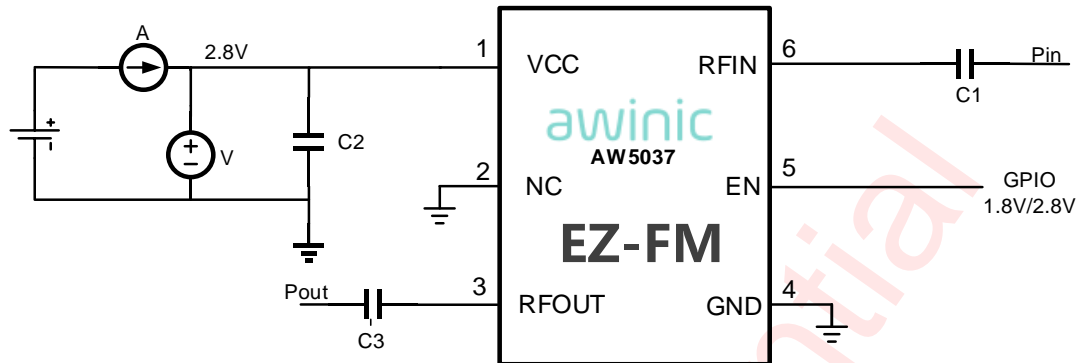

Figure 5 AW5037 DC Test Diagram

Test S-parameter

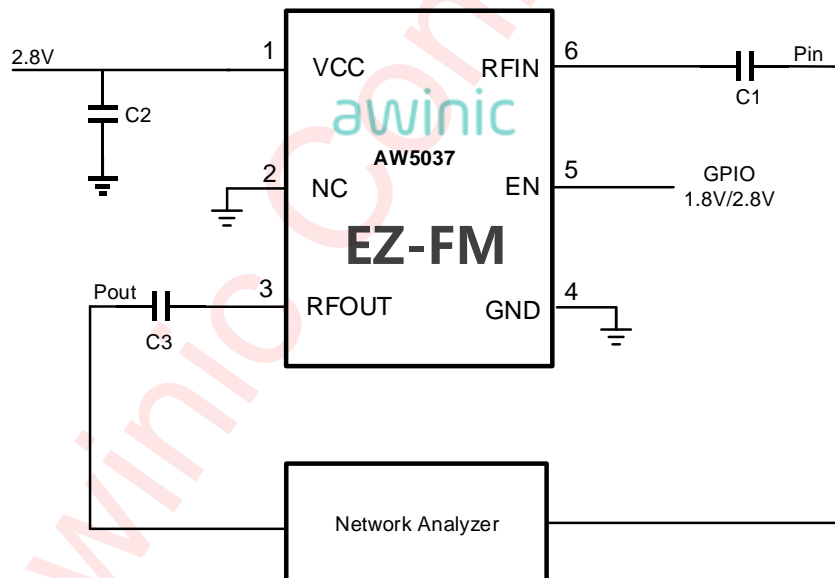

Figure 6 AW5037 S-parameter Measurement Diagram

Test Noise Figure

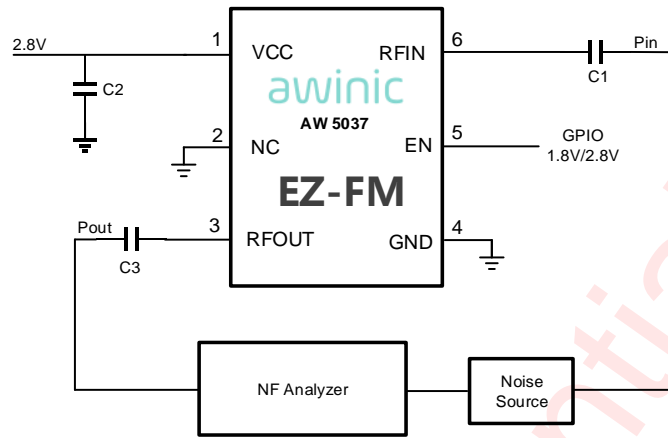

Figure 7 AW5037 Noise Figure Measurement Diagram

Test IIP3

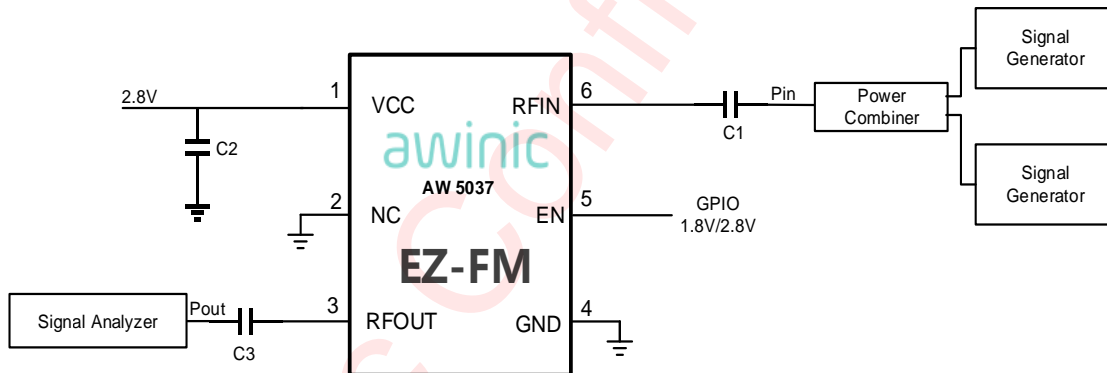

Figure 8 AW5037 IIP3 Measurement Diagram

APPLICATION INFORMATION

EN Control

AW5037 supports earphone as FM antenna. When baseband detects earphone insertion, GPIO will pull down to turn off AW5037 to avoid unnecessary power consumption.

Choice of Components

Taking Figure 1 as reference:

Filter block near PIFA antenna is composed of L6 and C3. These two components can be removed for Dipole antenna. Typical value of L6 is 120nH and C3 is 22pF.

Filter block of FM signal is composed of C1 and L1. Cellular RF signal goes through while FM signal is rejected. Typically C1 is 22pF and L1 is 120nH.

Matching circuit of FM signal path is composed of C4, L4, L5 and L7. FM signal goes through while cellular signal is rejected. Typically L4 is 100nH, L5 is 68nH and L7 is 33nH.

C5 is supply filtering capacitor. C6 is DC blocking capacitor. Both are 47nF typically.

C7 is added (value is 47nF), only if earphone is used as antenna.

Following tables show recommended inductor and capacitor values.

Inductor Selection Table

Part	Typical (nH)	Q (min)	Frequency (MHz)	MFR	Size
LQG15HS33NJ02	33	8	100	Murata	0402
LQG15HS68NJ02	68	8	100		0402
LQG15HSR12J02	120	8	100		0402
LQG15HSR10J02	100	8	100		0402
SDCL1005C33NJTDF	33	8	100	Sunlord	0402
SDCL1005C68NJTDF	68	8	100		0402
SDCL1005CR12JTDF	120	8	100		0402
SDCL1005CR10JTDF	100	8	100		0402

Capacitor Selection Table

Part	Typical	Voltage (V)	MFR	Size
GRM1555C1H220JA01	22pF	25	Murata	0402
GRM1555C1H390JA01	39pF	25		0402
GRM155R71C473KA01	47nF	16		0402

PACKAGE DESCRIPTION

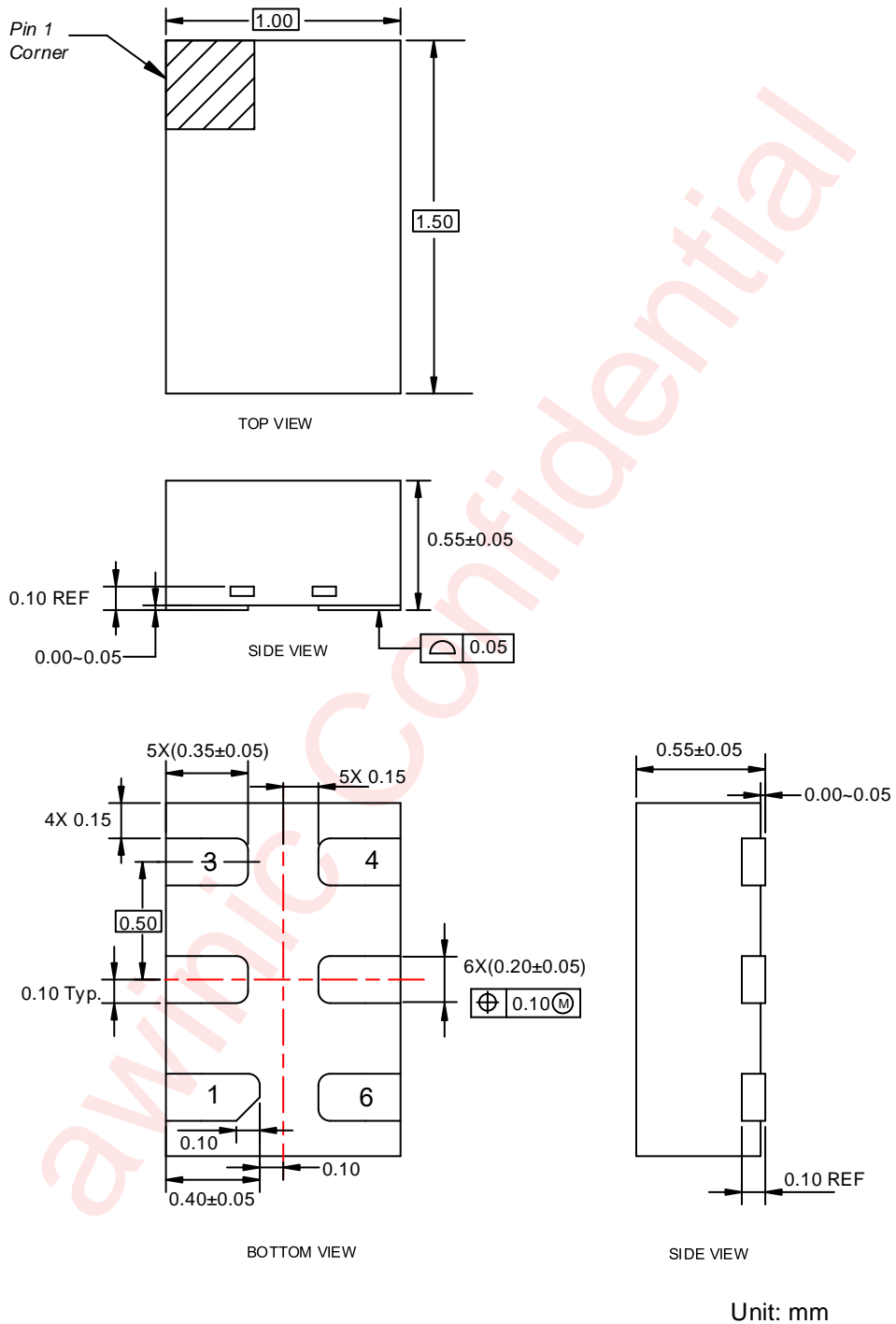
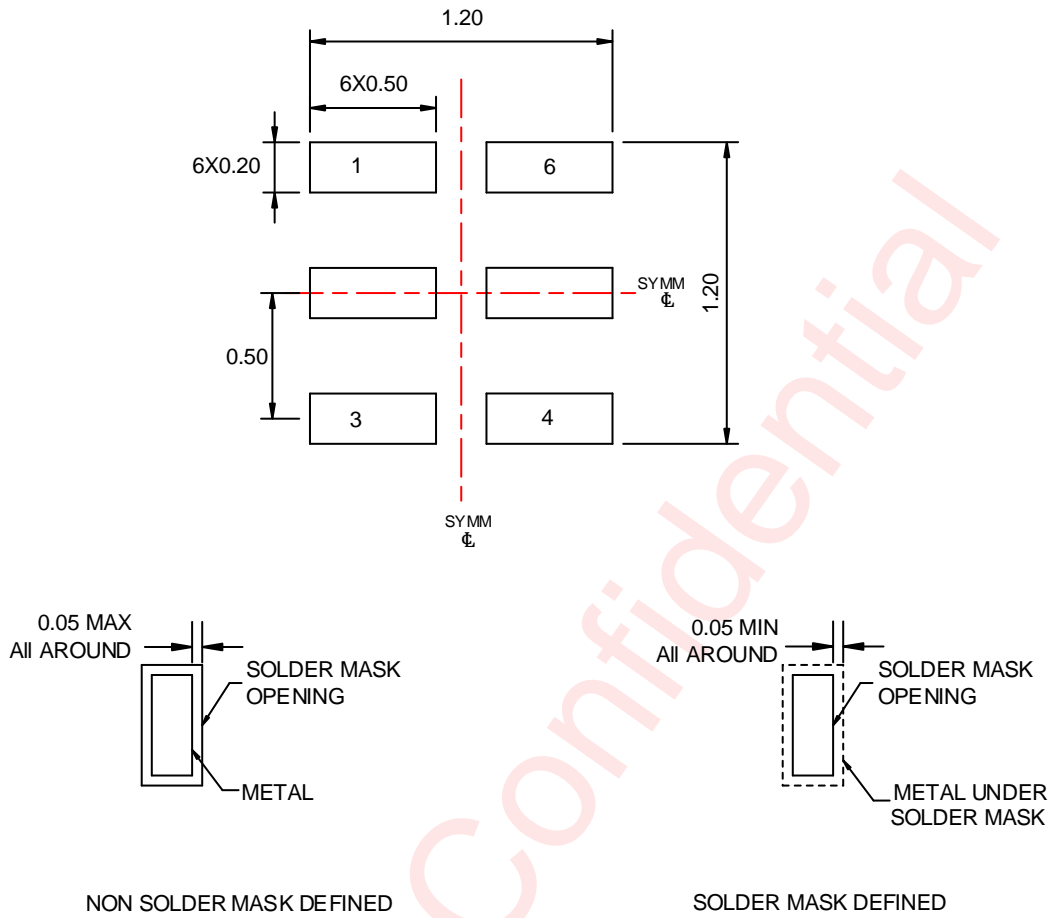

Figure 9 Package Outline

LAND PATTERN



Unit: mm

Figure 10 Land Pattern

TAPE & REEL DESCRIPTION

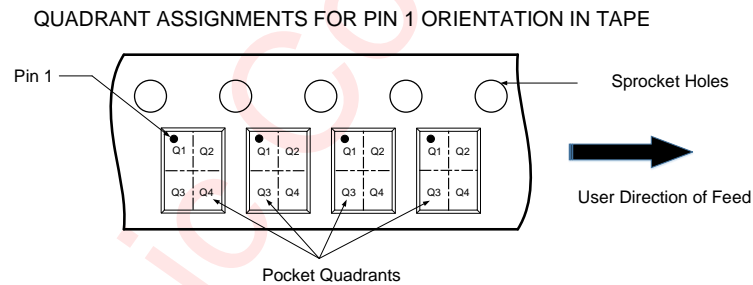
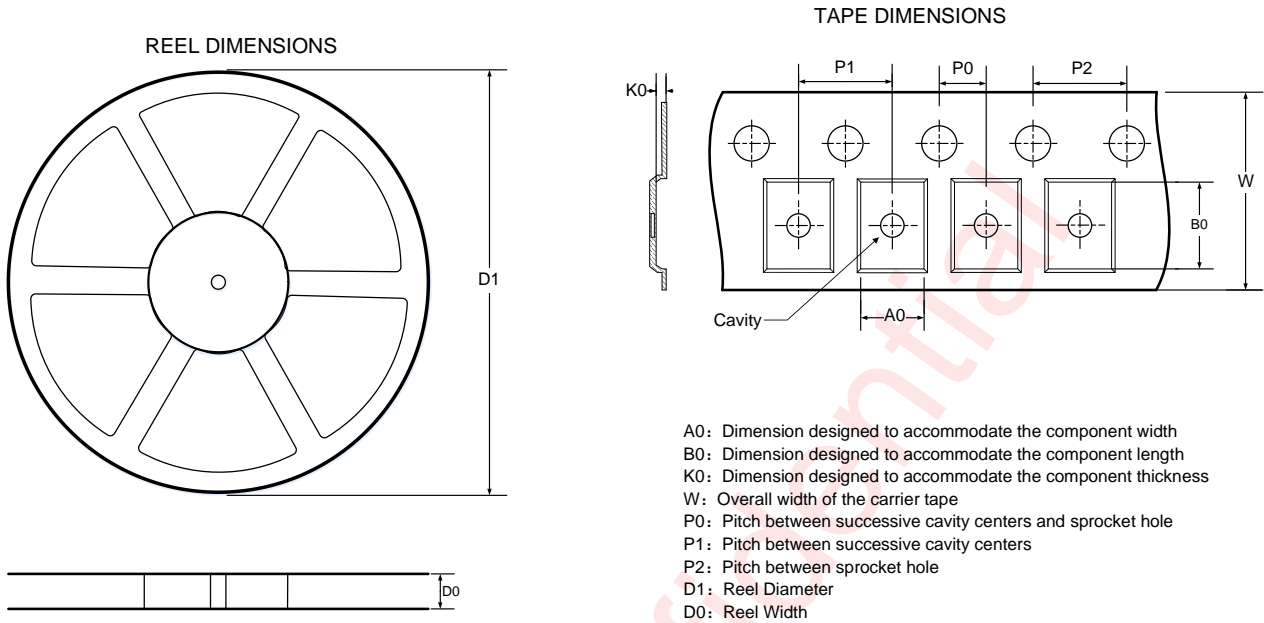

All Dimensions are nominal

D1 (mm)	D0 (mm)	A0 (mm)	B0 (mm)	K0 (mm)	P0 (mm)	P1 (mm)	P2 (mm)	W (mm)	Pin1 Quadrant
178	8.4	1.12	1.72	0.7	2	4	4	8	Q1

Figure 11 Tape & Reel Description

REVISION HISTORY

Document ID	Release date	Change notice	Supersedes
AW5037_V1.0	2018-11	Officially Released	-

DISCLAIMER

All trademarks are the property of their respective owners. Information in this document is believed to be accurate and reliable. However, Shanghai AWINIC Technology Co., Ltd (AWINIC Technology) does not give any representations or warranties, expressed or implied, as to the accuracy or completeness of such information and shall have no liability for the consequences of use of such information.

AWINIC Technology reserves the right to make changes to information published in this document, including without limitation specifications and product descriptions, at any time and without notice. Customers shall obtain the latest relevant information before placing orders and shall verify that such information is current and complete. This document supersedes and replaces all information supplied prior to the publication hereof.

AWINIC Technology products are not designed, authorized or warranted to be suitable for use in medical, military, aircraft, space or life support equipment, nor in applications where failure or malfunction of an AWINIC Technology product can reasonably be expected to result in personal injury, death or severe property or environmental damage. AWINIC Technology accepts no liability for inclusion and/or use of AWINIC Technology products in such equipment or applications and therefore such inclusion and/or use is at the customer's own risk.

Applications that are described herein for any of these products are for illustrative purposes only. AWINIC Technology makes no representation or warranty that such applications will be suitable for the specified use without further testing or modification.

All products are sold subject to the general terms and conditions of commercial sale supplied at the time of order acknowledgement.

Nothing in this document may be interpreted or construed as an offer to sell products that is open for acceptance or the grant, conveyance or implication of any license under any copyrights, patents or other industrial or intellectual property rights.

Reproduction of AWINIC information in AWINIC data books or data sheets is permissible only if reproduction is without alteration and is accompanied by all associated warranties, conditions, limitations, and notices. AWINIC is not responsible or liable for such altered documentation. Information of third parties may be subject to additional restrictions.

Resale of AWINIC components or services with statements different from or beyond the parameters stated by AWINIC for that component or service voids all express and any implied warranties for the associated AWINIC component or service and is an unfair and deceptive business practice. AWINIC is not responsible or liable for any such statements.