

7	8	9
标记 MARK	ECN编号/变更内容 ECN NO/DEFINITION	修改 REVISE
		日期 DATE
		核准 APPROVE

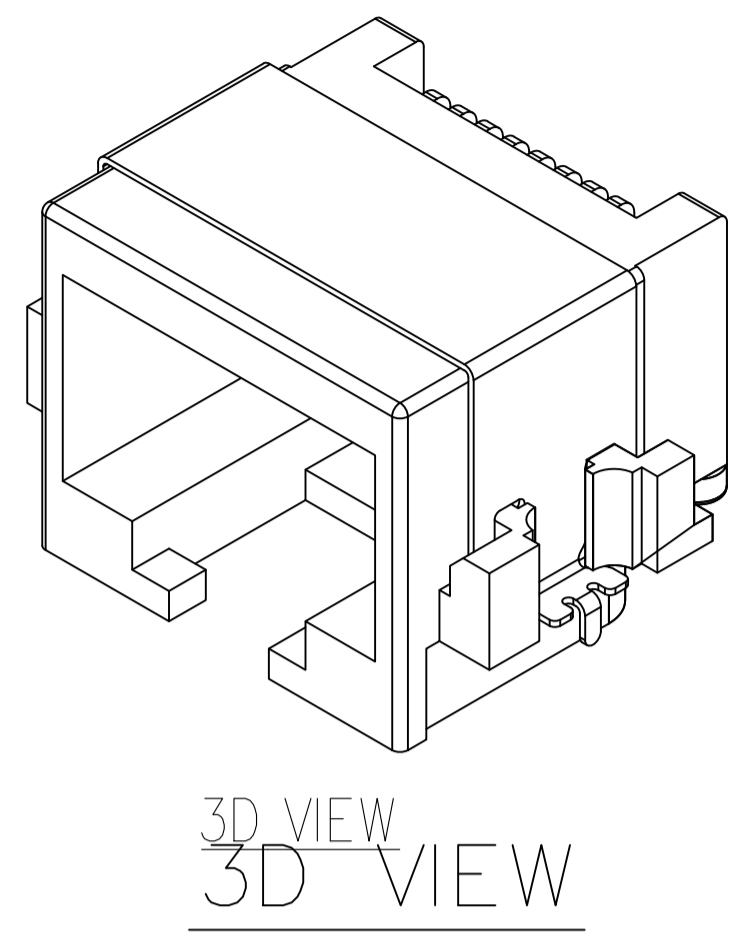

- NOTES:
- MATERIAL:
    - HOUSING: LCP ,COLOR IS BLACK;
    - CONTACT: PHOSPHOR COPPER (C5191 T=0.30mm);
    - SHIELD: STAINLESS STEEL (304 T=0.2mm);
  - FINISH:
    - CONTACT: PLATED OVER NI,GOLD PLATED G/Fu";
    - SHELL: PLATED OVER NI;
  - ELECTRICAL:
    - VOLTAGE RATING: 125 VAC RMS;
    - CURRENT RATING: 1.5 AMP;
    - CONTACT RESISTANCE: 35MILLIOHMS MAX.;
    - WITHSTAND VOLTAGE: 500 VAC RMS 50(60)Hz,1MIN.;
    - INSULATION RESISTANCE: 500MEGOHMS MIN @500V DC.;
  - MECHANICAL:
    - MATING/UNMATING FORCE: 22N MAX.;
    - RETENTION STRENGTH: 50N MIN.;
    - OPERATING LIFE: 750 CYCLES MIN.;
  - ENVIRONMENTAL:
    - STORAGE TEMPERATURE RANGE: -40°C~+85°C;
    - OPERATION TEMPERATURE RANGE: -25°C~+70°C;
  - SALT SPRAY TEST:8H(EXCLUDING RIVETED BENDS)

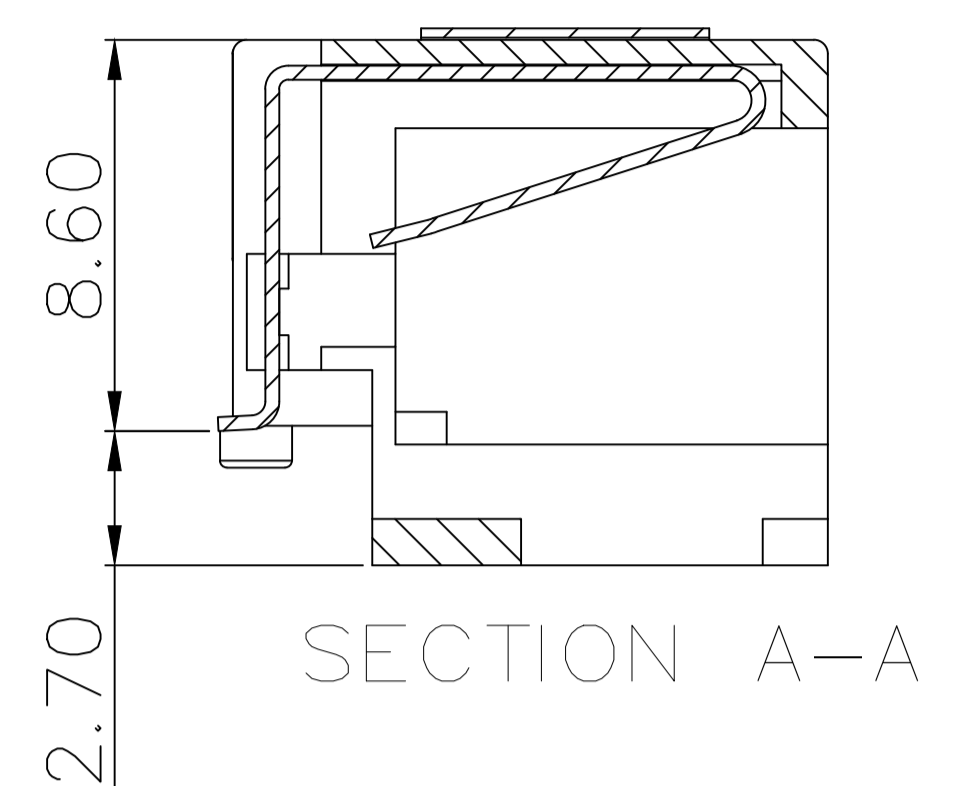
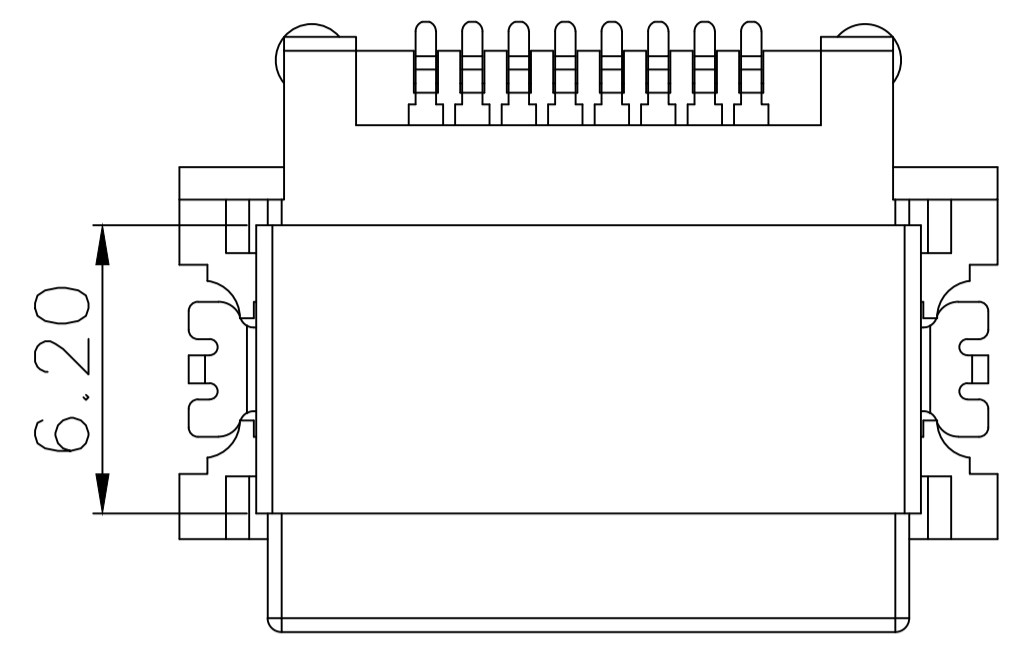
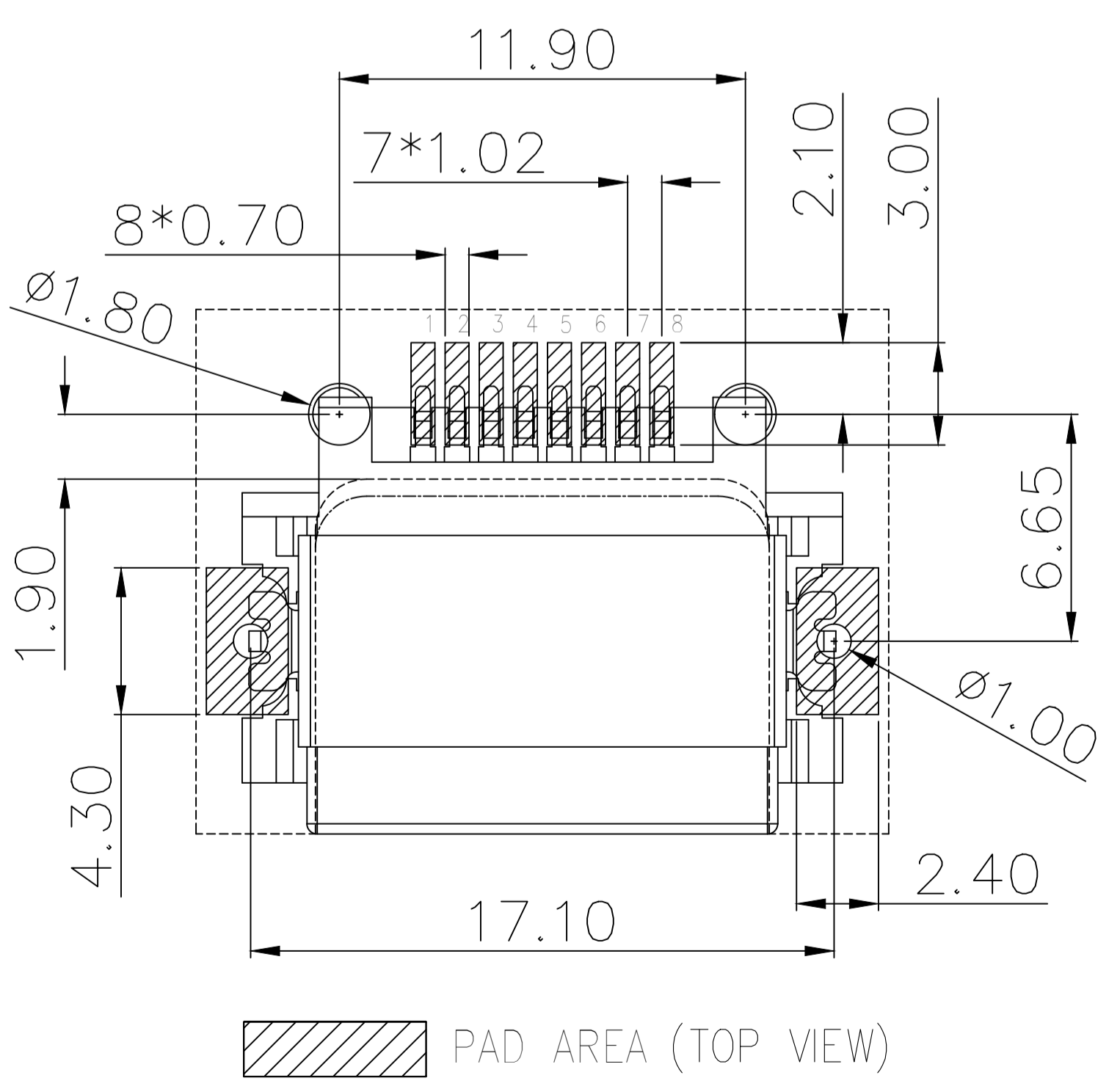
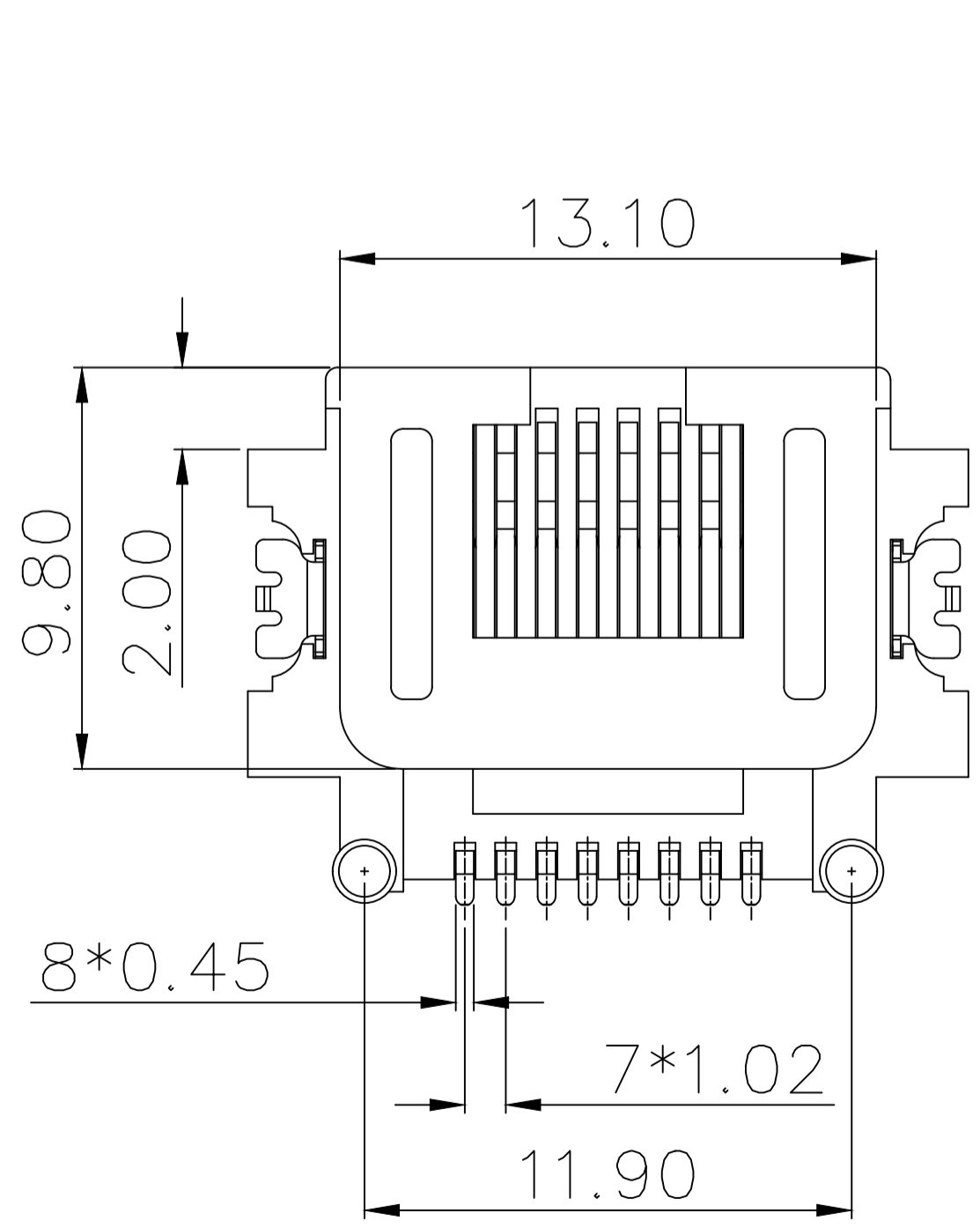
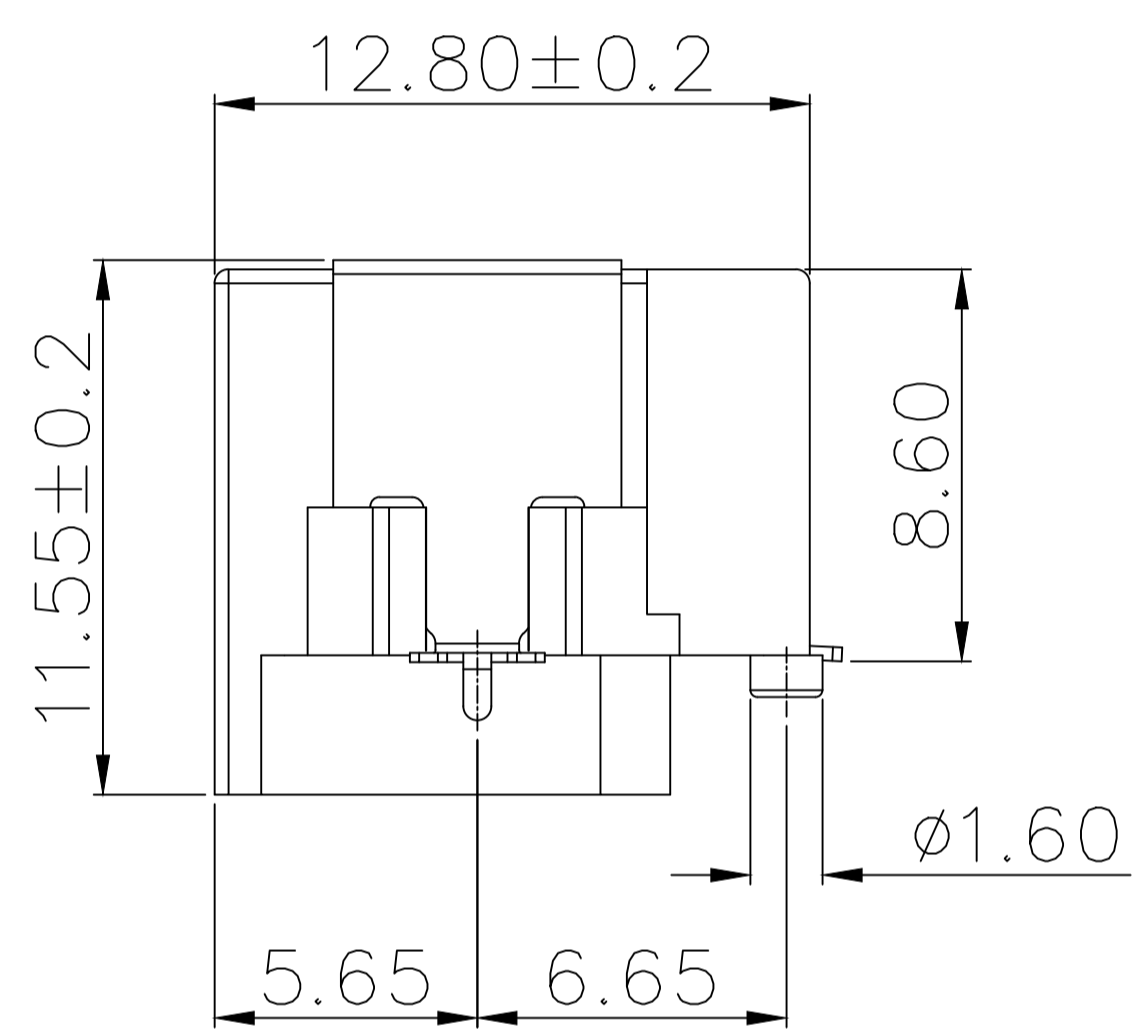
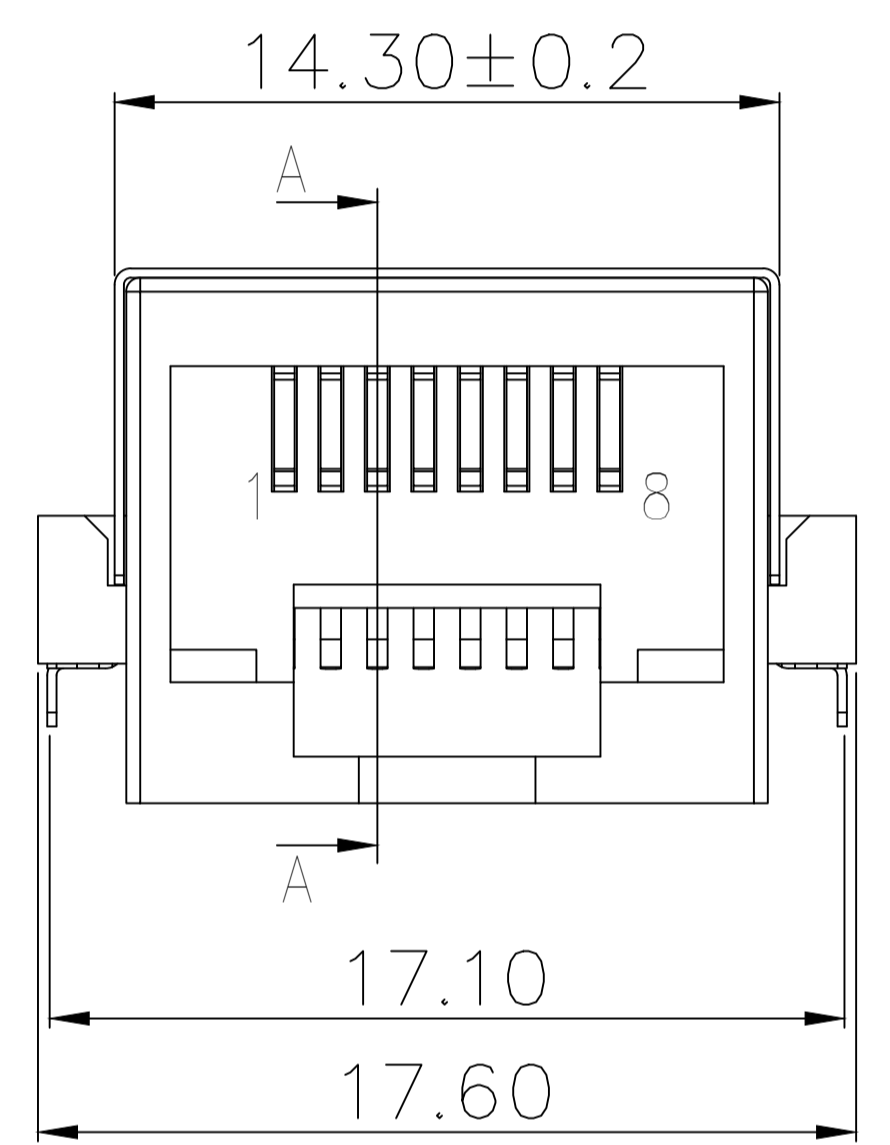

3	外壳	不锈钢	镀镍	
2	接触	铜	镀金G/F	
1	基座	LCP	黑色	
序号	品名	材质	电镀/颜色	备注

	深圳市虹成电子有限公司 品名 TITLE: 网口 料号 PART NO: HC-WK88-H865T-BB		
	UNLESS OTHERWISE, GENERAL TOLERANCE: X.xxx ±0.10 X.xx ±0.20 X.x ±0.30 ANGULAR: X.xx° ±1° X.x° ±3° X.° ±5°	比列 SCALE: 1:1 单位 UNIT: MM 张数 PART NO: 1 OF 1 版本 REV: A	

