

Standard 80-pin TQFP card with PIC18F87K22 MCU

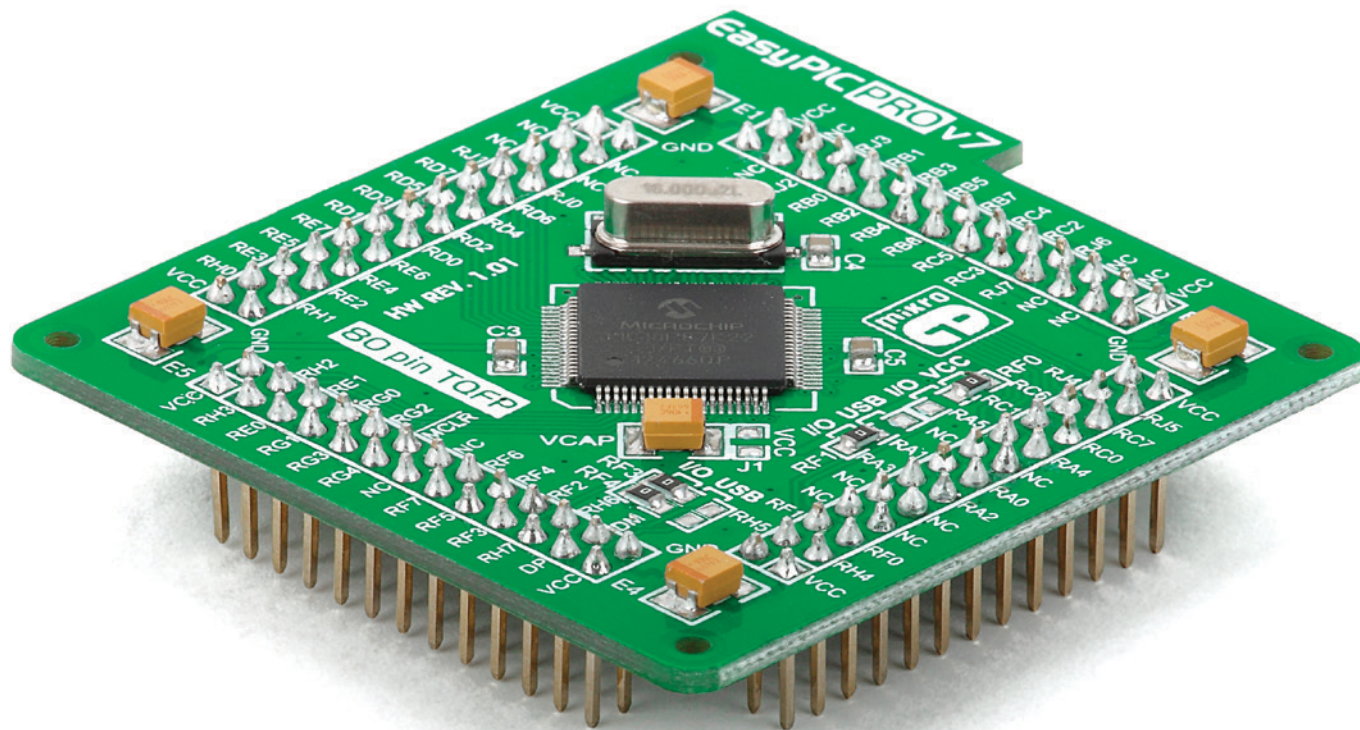

What's on Card

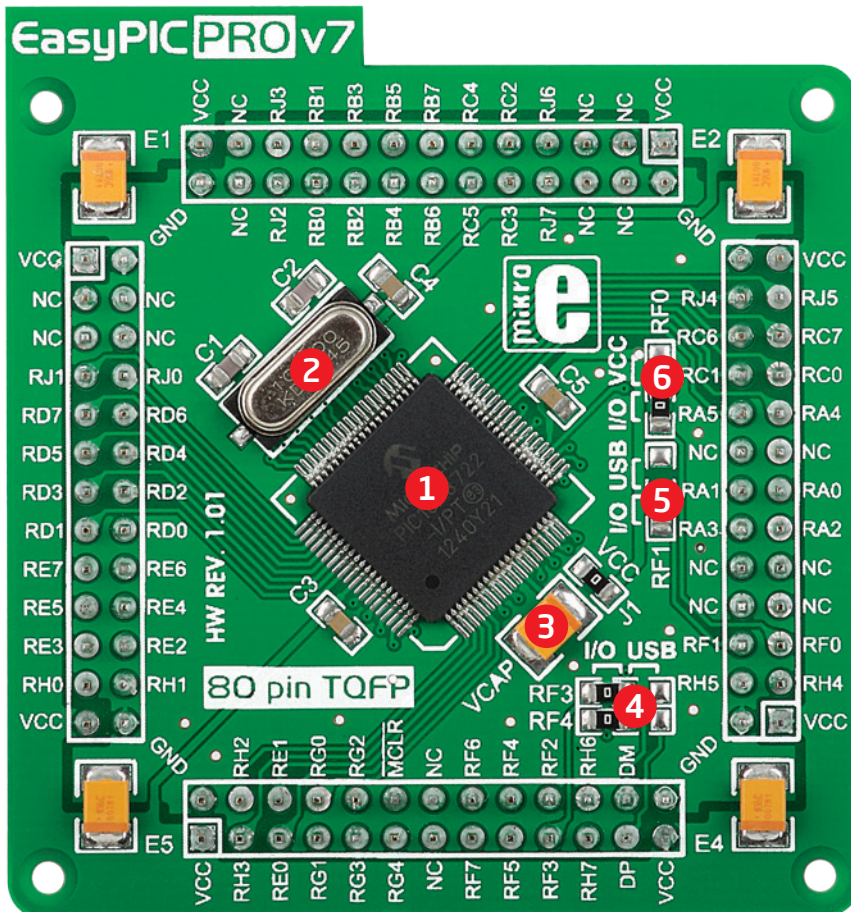

Figure 1: MCU card with PIC18F87K22

- 1 PIC18F87K22 microcontroller.** Featuring nanoWatt XLP™ technology, it has 16 MIPS operation, 128K bytes of linear program memory, 3896 bytes of linear data memory, and support for a wide range of power supply from 1.8V to 5V.
- 2 16MHz crystal oscillator.** We carefully chose the most convenient crystal value that provides clock frequency which can be used directly, or with the PLL multipliers and dividers to create higher MCU clock value.
- 3 VCAP jumper.** Some PIC18FK and all PIC18FJ microcontrollers have cores that work on 1.8V-2.5V voltage range, and peripherals that work with 3.3V and 5V voltages. Internally, those microcontrollers have power regulators which adjust the core voltage levels. In order for those devices to have a stable operation of the core, manufacturer recommends that decoupling capacitive filters should be provided, and connected between specific microcontroller pins designated with VCAP and GND. This MCU card provides a VCAP jumper which is used for this purpose. **Jumper is removed by default.**
- 4 USB communication lines.** These two jumpers, when in USB position, connect **D+** and **D-** lines of the on-board USB connector with **RF3** and **RF4** microcontroller pins. Since PIC18F87K22 doesn't support USB, **jumpers are in I/O position.**
- 5 Vusb line jumper.** For PIC18F8xJ5x devices, this jumper should be connected to VCC for enabling internal USB controller. Since PIC18F87K22 doesn't support USB, **this jumper is in I/O position.**
- 6 ENVREG selection jumper.** PIC18FJ and PIC18FK microcontrollers are using internal voltage regulator which is enabled by placing this jumper in **VCC position.**

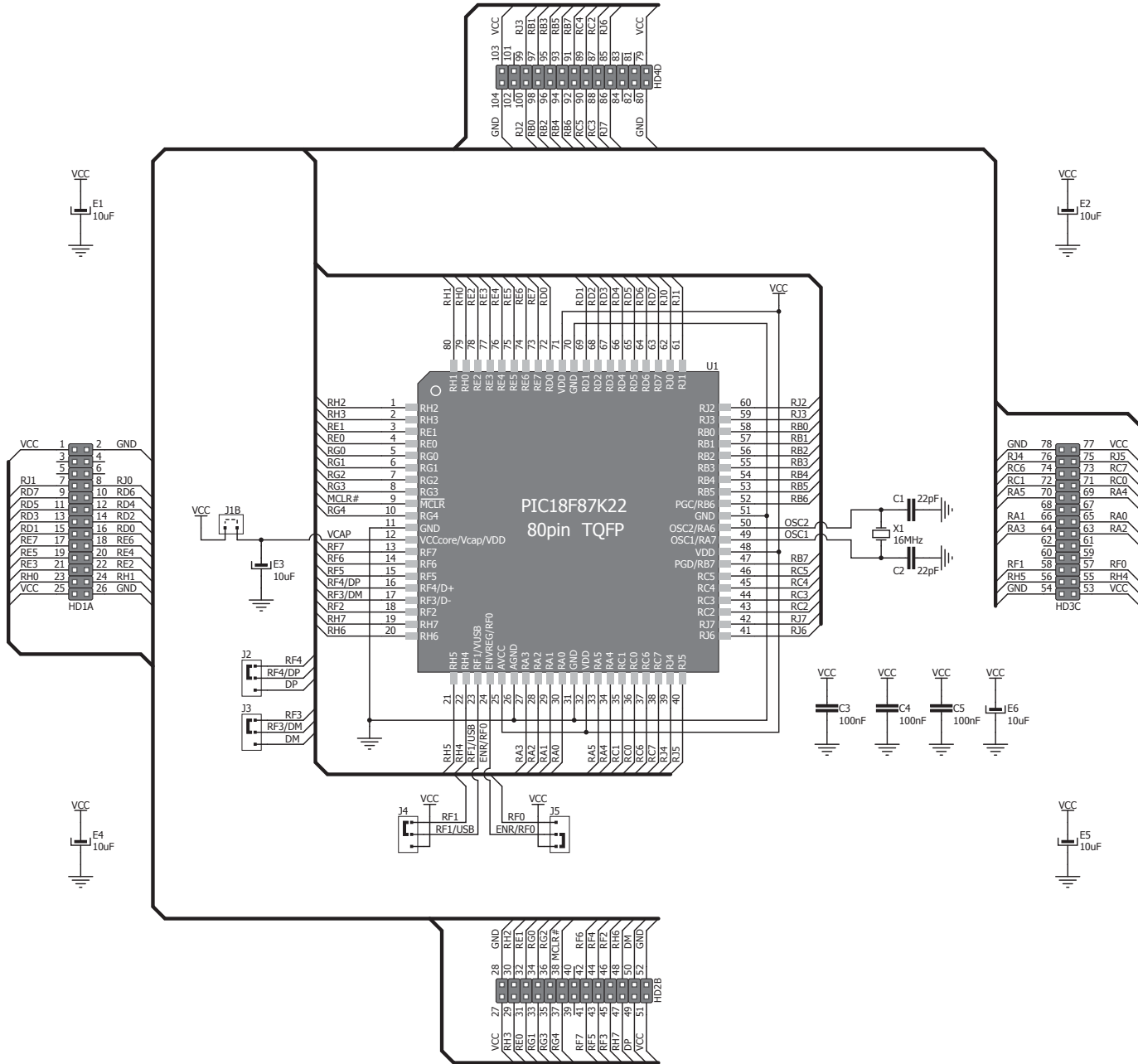

Figure 2: MCU card schematics

Card dimensions

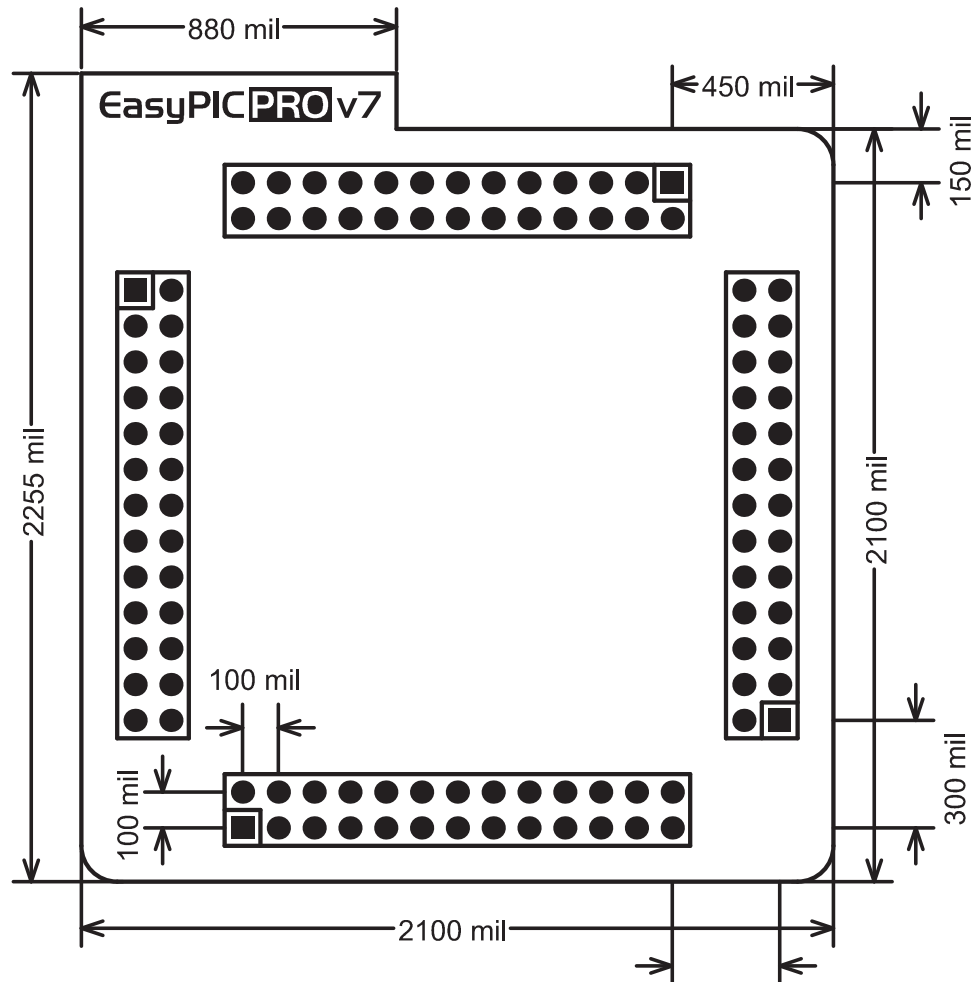
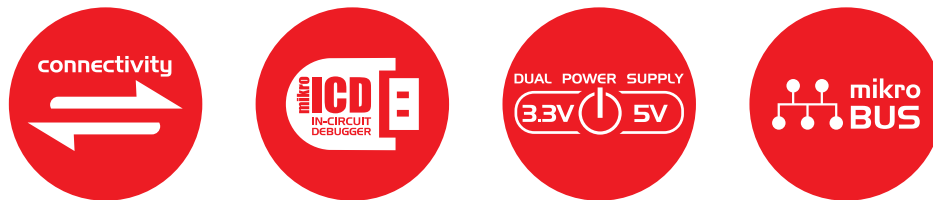

Figure 3: MCU card dimensions. Values are in mils.



If you want to learn more about our products, please visit our website at www.mikroe.com

If you are experiencing some problems with any of our products or just need additional information, please place your ticket at www.mikroe.com/support

If you have any questions, comments or business proposals,
do not hesitate to contact us at office@mikroe.com