

# Low Noise, Low Cost, Precision Instrumentation Amplifier

## Features

- Setting the Gain from 1 to 10,000 using an external resistor
- High CMRR (Common Mode Rejection Ratio): 93 dB (Min),  $G = 10$
- Low Input Offset Voltage: 125  $\mu\text{V}$  (Max)
- Low Input Offset Voltage Drift: 0.3  $\mu\text{V}/^\circ\text{C}$
- Low Input Bias Current: 0.5 nA (Max)
- Low Input Voltage Noise: 8  $\text{nV}/\sqrt{\text{Hz}}$
- Low frequency noise: 2  $\mu\text{V}_{\text{P-P}}$  (0.1 to 10 Hz,  $G = 1$ )
- Bandwidth: 625 kHz @  $G = 10$
- Power supply current: 3.3 mA
- Supply voltage:  $\pm 2.4 \text{ V}$  to  $\pm 18 \text{ V}$
- Wide temperature range:  $-40^\circ\text{C}$  to  $+85^\circ\text{C}$

## Applications

- Precision data acquisition
- ECG monitoring equipment
- Instrumentation
- Bridge circuit and other sensor signal conditioning
- Industrial control

## General Description

The AWS72922/AWS72928 is a precision, low-noise instrumentation amplifier that can be used to set the gain range from 1 to 10,000 with a single external resistor.

The AWS72922/AWS72928 is based on classic three-op-amp structure to provide high common-mode rejection ratio (CMRR) over 93dB at the gain of 10. This allows it to accurately amplify useful signals in the presence of large external interference, which is a common situation in precision data acquisition, bridge sensor interface, thermocouples, and medical signal acquisition.

The AWS72922/AWS72928 has both excellent DC and fast AC performance. Its input offset voltage is less than 125  $\mu\text{V}$ , with a typical temperature drift coefficient of 0.2  $\mu\text{V}/^\circ\text{C}$  and an input bias current within 0.5 nA, significantly simplifying system calibration costs. The noise is 8  $\text{nV}/\sqrt{\text{Hz}}$  at 1 kHz, and the 0.1 Hz to 10 Hz noise is 2  $\mu\text{V}_{\text{pp}}$  at the gain of 10, making it highly suitable for the first stage of precision circuits. At a gain of 10, the AWS72922/AWS72928 has a bandwidth of 625kHz, a slew rate of 2V/ $\mu\text{s}$ , and a 0.01% settling time of 6.3 $\mu\text{s}$ , making it suitable for precision multi-channel switching data acquisition systems.

AWS72922/AWS72928 guarantees performance over a wide temperature range from  $-40^\circ\text{C}$  to  $+85^\circ\text{C}$ . It can operate with a maximum supply voltage of  $\pm 18 \text{ V}$  and a minimum supply voltage of  $\pm 2.4 \text{ V}$ . The AWS72922/AWS72928 is available in a SOP-8L package.

## Typical Application Circuit

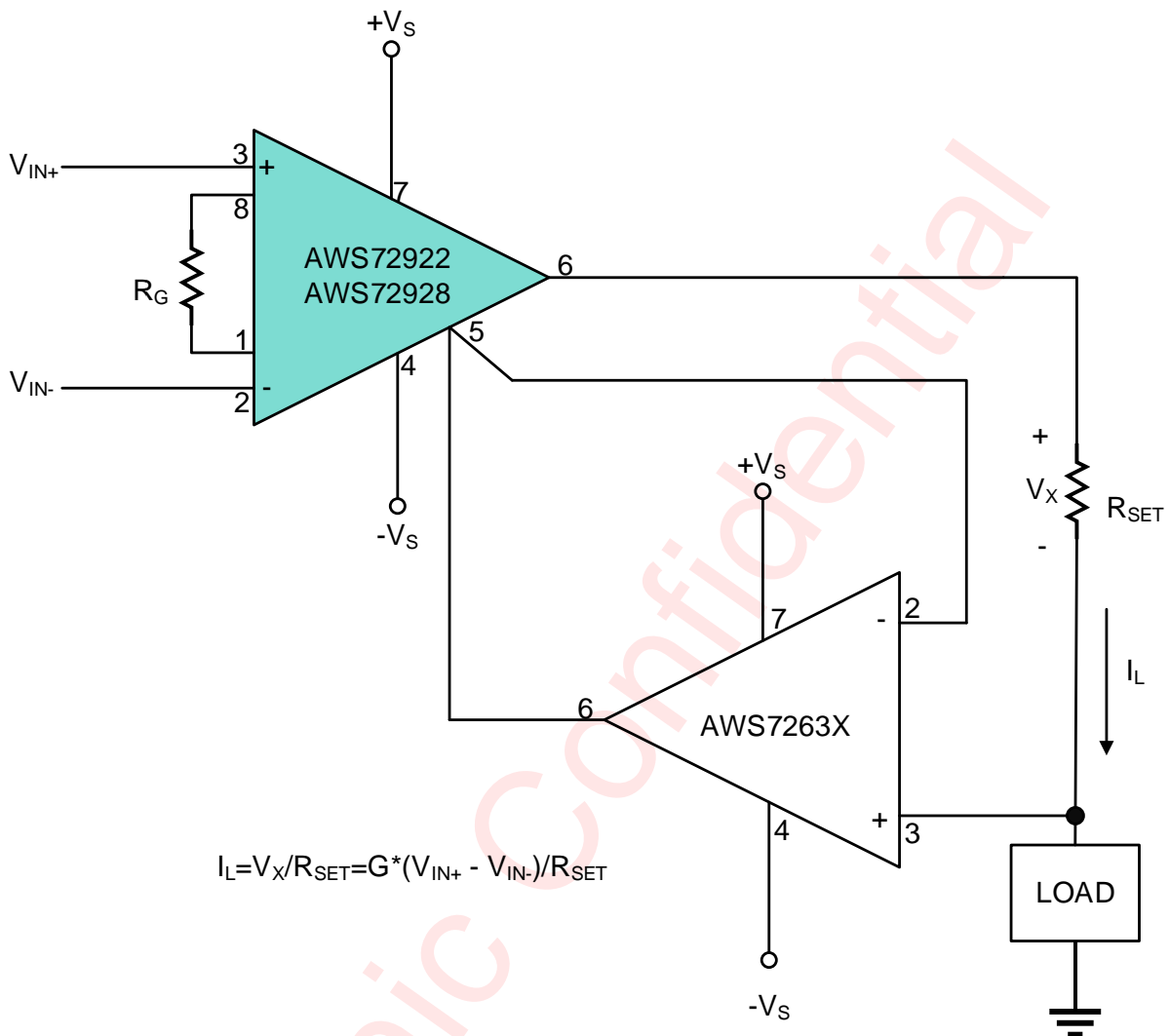
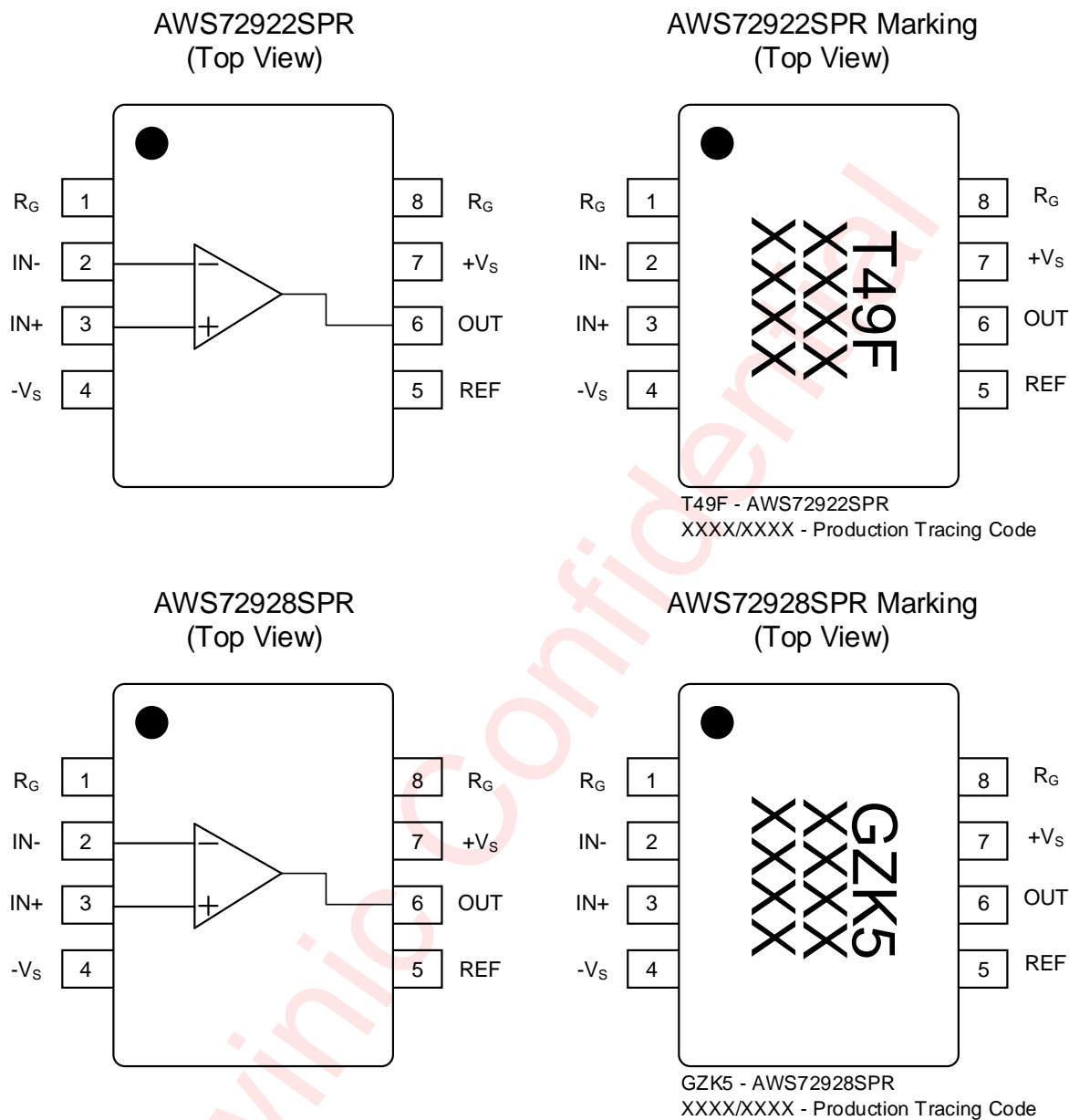

Figure 1. Typical Application Circuit of AWS72922/AWS72928

## Pin Configuration And Top Mark



**Figure 2. Pin Configuration and Top Mark**

## Pin Definition

No.	Name	Description
1	R <sub>G</sub>	Gain setting pin. Place a gain resistor between pin 1 and pin 8.
2	IN-	Inverting input
3	IN+	Non-Inverting input
4	-V <sub>s</sub>	Negative power supply
5	REF	Output reference level input
6	OUT	Output of signal
7	+V <sub>s</sub>	Positive power supply
8	R <sub>G</sub>	Gain setting pin. Place a gain resistor between pin 1 and pin 8.

## Ordering Information

Part Number	Temperature	Package	Marking	Moisture Sensitivity Level	Environmental Information	Delivery Form
AWS72922SPR	-40 °C~85 °C	SOP - 8L	T49F	MSL1	ROHS+HF	4000 units/ Tape and Reel
AWS72928SPR	-40 °C~85 °C	SOP - 8L	GZK5	MSL1	ROHS+HF	4000 units/ Tape and Reel

## Absolute Maximum Ratings<sup>(NOTE1)</sup>

PARAMETERS	RANGE
Supply voltage, $V_s = (+V_s) - (-V_s)$	-0.3 V~40 V
Input Voltage	$\pm V_s$
Differential Input voltage( $G=1\sim 10$ )	$(+V_s) - (-V_s)$
Input Current <sup>(NOTE 2)</sup>	$\pm 10$ mA
Output short-circuit <sup>(NOTE 3)</sup>	Continuous
Operating free-air temperature range $T_A$	-40 °C to 85 °C
Storage temperature $T_{STG}$	-65 °C to 150 °C
Maximum operating junction temperature $T_{JMAX}$	150 °C
Lead temperature (soldering 10 seconds)	260 °C

NOTE1: These ratings apply at 25 °C, unless otherwise noted. Note that stresses above those listed under Absolute Maximum Ratings may cause permanent damage to the device. This is a stress rating only, functional operation of the device at these or any other conditions above those indicated in the operational section of this specification is not implied. Exposure to absolute maximum rating conditions for extended periods may affect device reliability.

NOTE2: There are clamping diodes between the input pins and the power pins, and also between each other. When the input signal exceeds the supply rail by 0.3 V, the input current is limited to 10 mA.

NOTE3: Limited by Over Temperature Protection (OTP).

## ESD Rating<sup>(NOTE 4)</sup>

PARAMETERS	VALUE	UNIT
HBM (Human Body Model) <sup>(NOTE 5)</sup>	3	kV
CDM <sup>(NOTE 6)</sup>	2	kV

NOTE4: Charged devices and circuit boards can discharge without detection. Although this product features patented or proprietary protection circuitry, damage may occur on devices subjected to high energy ESD. Therefore, proper ESD precautions should be taken to avoid performance degradation or loss of functionality.

NOTE5: ANSI/ESDA/JEDEC JS-001-2017.

NOTE6: ANSI/ESDA/JEDEC JS-002-2018.

## Thermal Information<sup>(NOTE 7)</sup>

THERMAL METRICS		AWS72922SPR	AWS72928SPR	UNIT
SYMBOL	PARAMETER			
$R_{\theta JA}$	Junction-to-ambient thermal resistance	158	158	°C/W
$R_{\theta JC}$	Junction-to-case (top) thermal resistance	43	43	°C/W

NOTE 7: $\theta_{JA}$  addresses the conditions for soldering devices onto circuit boards to achieve surface mount packaging.

## Electrical Characteristics

Unless otherwise noted,  $V_S = \pm 15\text{ V}$ ,  $V_{REF} = 0\text{ V}$ ,  $G = 1$ ,  $R_L = 2\text{ k}\Omega$ ,  $T_A = 25^\circ\text{C}$ .

PARAMETER		TEST CONDITION	MIN	TYP	MAX	UNIT
Gain		AWS72922: $G = 1 + (49.4\text{ k}\Omega / R_G)$ AWS72928: $G = 1 + (50\text{ k}\Omega / R_G)$				
Range of Gain			1		10000	
GE	Gain Error	$V_{OUT} = \pm 10\text{ V}$	$G = 1$	-0.10	0.10	%
			$G = 10$	-0.30	0.30	%
			$G = 100$	-0.30	0.30	%
			$G = 1000$	-0.70	0.70	%
Gain Nonlinearity		$G = 1 \sim 100$ , $V_{OUT} = \pm 10\text{ V}$	$R_L = 10\text{ k}\Omega$	10	50	ppm
			$R_L = 2\text{ k}\Omega$	10	95	ppm
Gain vs Temperature		$T_A = -40^\circ\text{C}$ to $85^\circ\text{C}$ , $G = 1$			10	ppm/ $^\circ\text{C}$
		$T_A = -40^\circ\text{C}$ to $85^\circ\text{C}$ , $G > 1^{(8)}$	-50		50	ppm/ $^\circ\text{C}$
<b>Offset Voltage</b>						
$V_{OS}$	Offset Voltage	Total Offset Voltage to Input = $V_{OSI} + V_{OSO} / G$				
$V_{OSI}$	Input Offset Voltage	$V_S = \pm 4.5\text{ V} \sim \pm 16.5\text{ V}$	-125		125	$\mu\text{V}$
$TCV_{OSI}$	Average TC	$V_S = \pm 4.5\text{ V} \sim \pm 16.5\text{ V}$		0.3	1.0	$\mu\text{V}/^\circ\text{C}$
$V_{OSO}$	Output Offset Voltage	$V_S = \pm 4.5\text{ V} \sim \pm 16.5\text{ V}$	-1000	200	1000	$\mu\text{V}$
$TCV_{OSO}$	Average TC	$V_S = \pm 4.5\text{ V} \sim \pm 16.5\text{ V}$		5	15	$\mu\text{V}/^\circ\text{C}$
<b>Power Supply Rejection Ratio</b>						
PSRR	Power Supply Rejection Ratio	$V_S = \pm 2.4\text{ V} \sim \pm 18\text{ V}$ , $G = 1$	80	100		dB
		$V_S = \pm 2.4\text{ V} \sim \pm 18\text{ V}$ , $G = 10$	95	120		dB
		$V_S = \pm 2.4\text{ V} \sim \pm 18\text{ V}$ , $G = 100$	110	140		dB
		$V_S = \pm 2.4\text{ V} \sim \pm 18\text{ V}$ , $G = 1000$	110	140		dB
<b>Input Characteristics</b>						
$I_B$	Input bias current	$V_S = \pm 16.5\text{ V}$		0.1	0.5	nA
$TCI_B$	Average TC	$V_S = \pm 16.5\text{ V}$ , $T_A = -40 \sim 85^\circ\text{C}$		3		$\text{pA}/^\circ\text{C}$
$I_{OS}$	Input offset current	$V_S = \pm 16.5\text{ V}$	-0.25		0.25	nA
$R_{IN} / C_{IN}$	Input Impedance	Differential Mode		100/2		$\text{G}\Omega / \text{pF}$
		Common Mode		100/2		$\text{G}\Omega / \text{pF}$
IVR	Input Operating Voltage Range <sup>(9)</sup>	$V_S = \pm 2.4\text{ V} \sim \pm 15\text{ V}$	$-V_S + 0.5$		$+V_S - 1.2$	V

CMRR	Common-Mode Rejection Ratio	G = 1	73	90		dB
		G = 10	93	110		dB
		G = 100	110	130		dB
		G = 1000	110	130		dB
<b>Output Characteristics</b>						
V <sub>o</sub>	Output Swing	V <sub>S</sub> = ± 2.4 V ~ ± 15 V	- V <sub>S</sub> + 0.3		+ V <sub>S</sub> - 0.3	V
I <sub>sc</sub>	Short-Circuit Current	Source		90		mA
		Sink		50		mA
<b>Dynamic Performance</b>						
Small Signal Bandwidth, -3dB		G = 1		3200		kHz
		G = 10		625		kHz
		G = 100		70		kHz
		G = 1000		9		kHz
SR	Slew Rate		0.75	2		V/μs
t <sub>s</sub>	Settling Time (to 0.01 %)	G = 1~10, 0 V to 10 V step		6.5		μs
		G = 100, 0 V to 10 V step		23		μs
		G = 1000, 0 V to 10 V step		213		μs
<b>Noise Performance</b>						
e <sub>ni</sub>	Input Voltage Noise	f = 1kHz		8		nV/√Hz
e <sub>no</sub>	Output Voltage Noise	f = 1kHz		75		nV/√Hz
RTI	Reduced to input noise	G = 1, f = 0.1 Hz to 10 Hz		2		μV <sub>P-P</sub>
		G = 10, f = 0.1 Hz to 10 Hz		0.9		μV <sub>P-P</sub>
		G = 100, f = 0.1 Hz to 10Hz		0.9		μV <sub>P-P</sub>
i <sub>n</sub>	Input Current Noise	f = 1 kHz		0.8		fA/√Hz
		f = 0.1 Hz to 10 Hz		6		pA <sub>P-P</sub>
<b>Reference Input</b>						
R <sub>IN</sub>	Input impedance			20		kΩ
I <sub>IN</sub>	Input current	V <sub>S</sub> = ± 16.5 V		0.03	0.3	μA
V <sub>REF</sub>	Voltage Range		- V <sub>S</sub> + 0.5		+ V <sub>S</sub> - 1.2	V
Reference Gain to Output				1±0.000 1		
<b>Power Supply</b>						
V <sub>S</sub>	Operating Range		± 2.4		± 18	V
I <sub>Q</sub>	Quiescent Current			3.3	3.8	mA

NOTE8: The values specified for G > 1 do not include the effects of the external gain-setting resistor, R<sub>G</sub>.

NOTE9: One input is connected to ground.

### Typical Characteristics

$V_S = \pm 15\text{ V}$ ,  $I_{LOAD} = 0$ ,  $C_L = 0.1\ \mu\text{F}$ ,  $T_A = 25\text{ }^\circ\text{C}$ , unless otherwise noted.

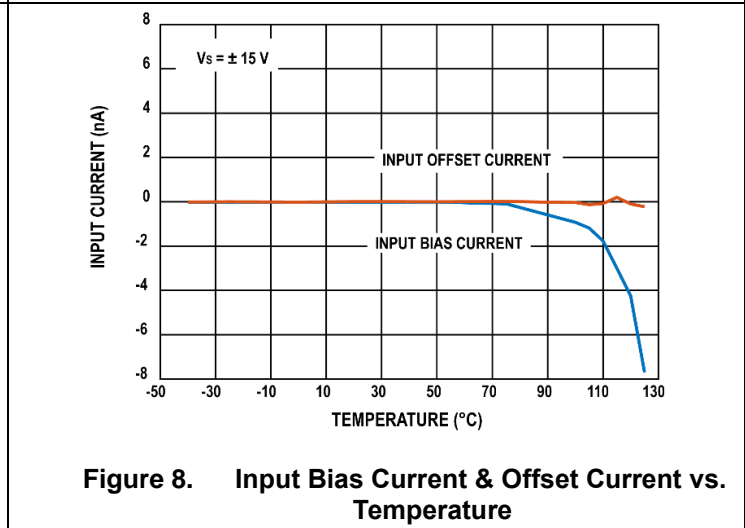
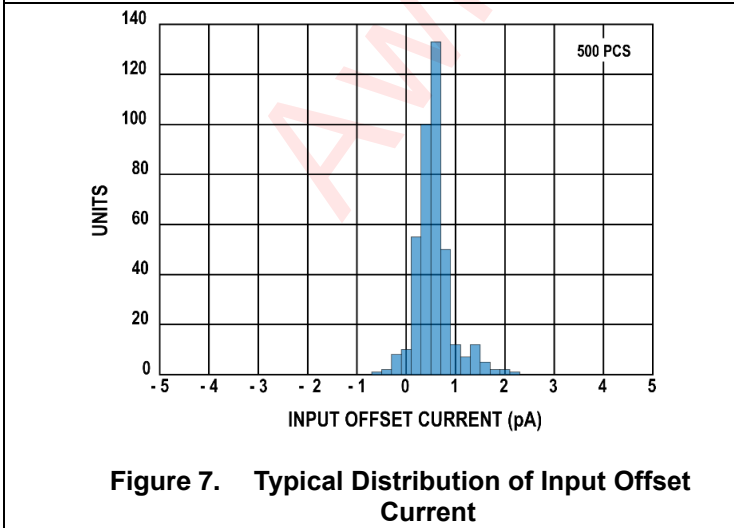
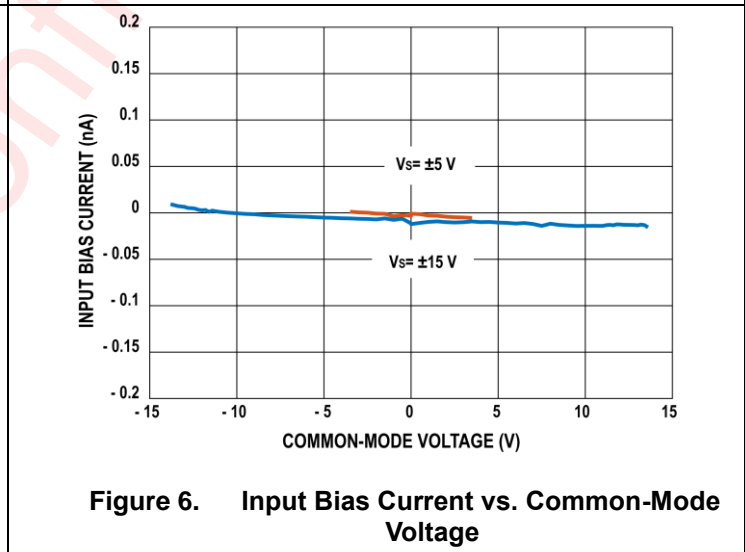
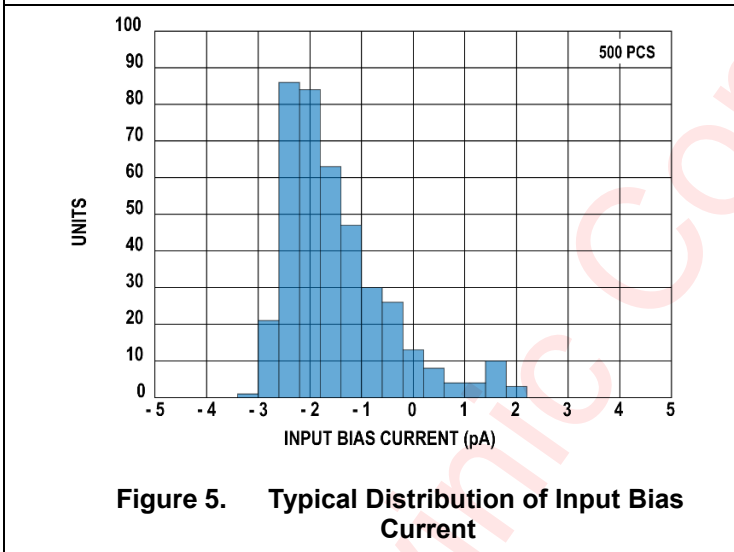
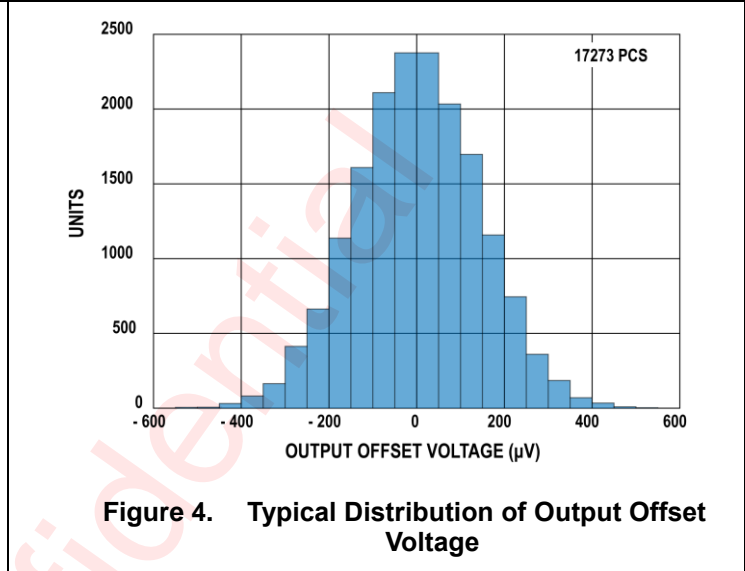
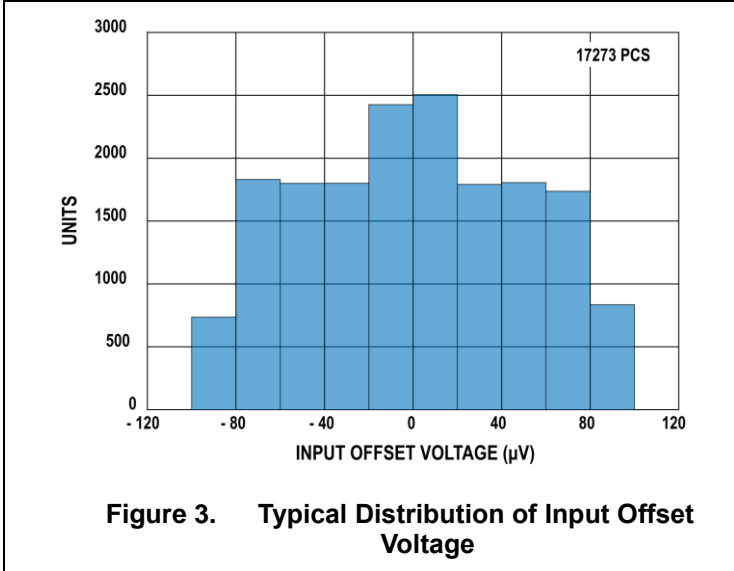

Typical Characteristics(Continued)

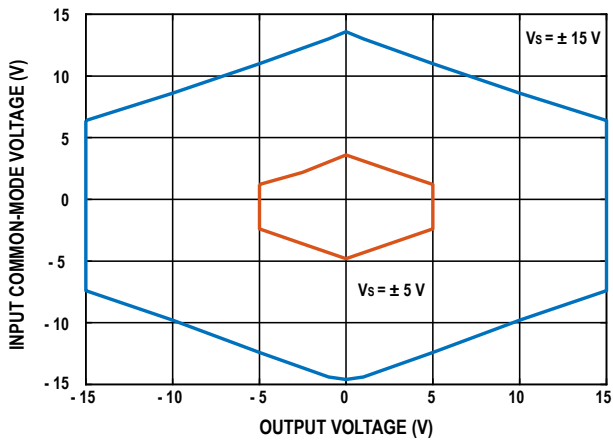

Figure 9. Input Common-Mode Voltage vs. Output Voltage (G = 1)

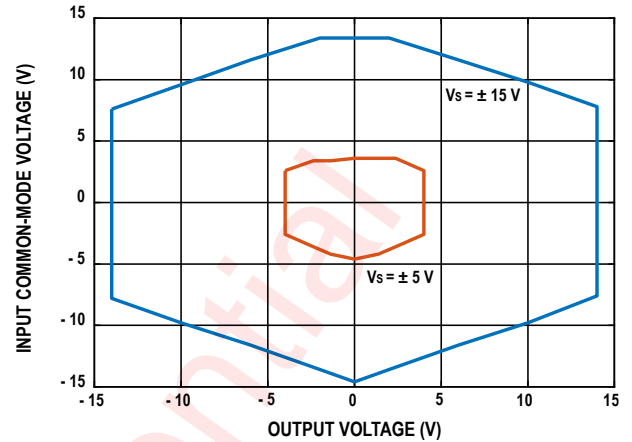

Figure 10. Input Common-Mode Voltage vs. Output Voltage (G = 100)

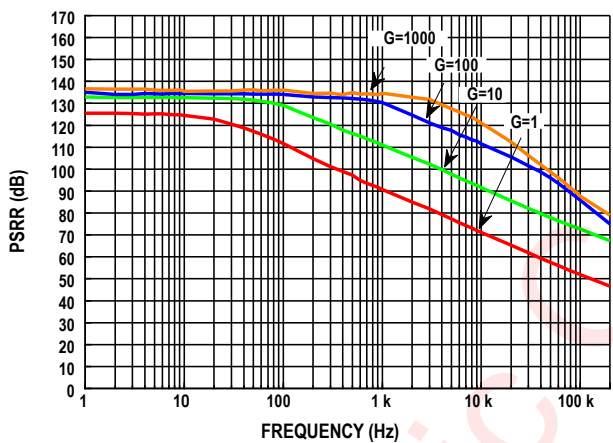

Figure 11. Positive Power Supply Rejection Ratio (PSRR) vs. Frequency, RTI (G = 1 to 1000)

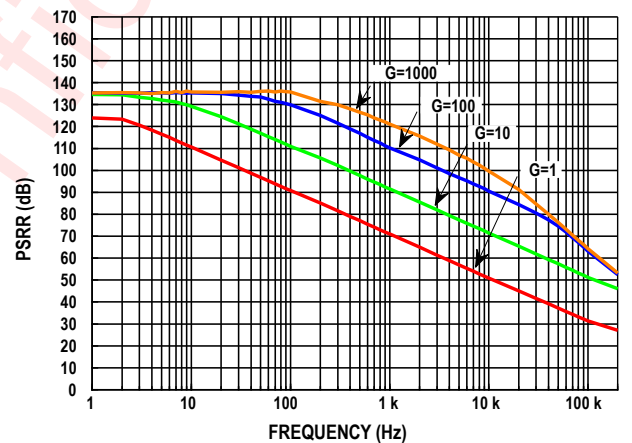

Figure 12. Negative Power Supply Rejection Ratio (PSRR) vs. Frequency, RTI (G = 1 to 1000)

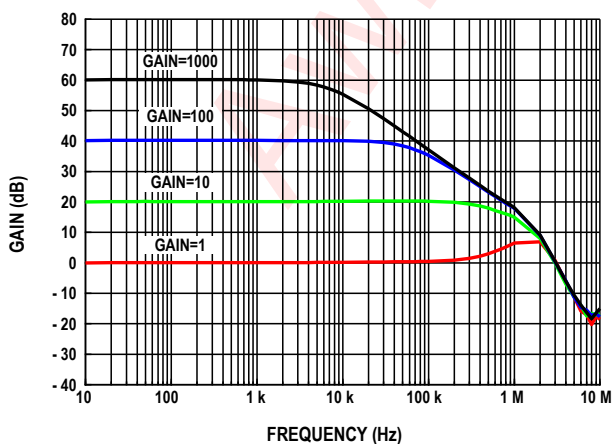

Figure 13. Gain vs. Frequency

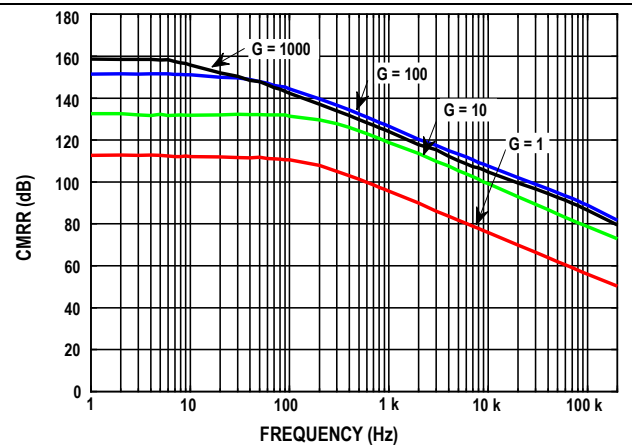
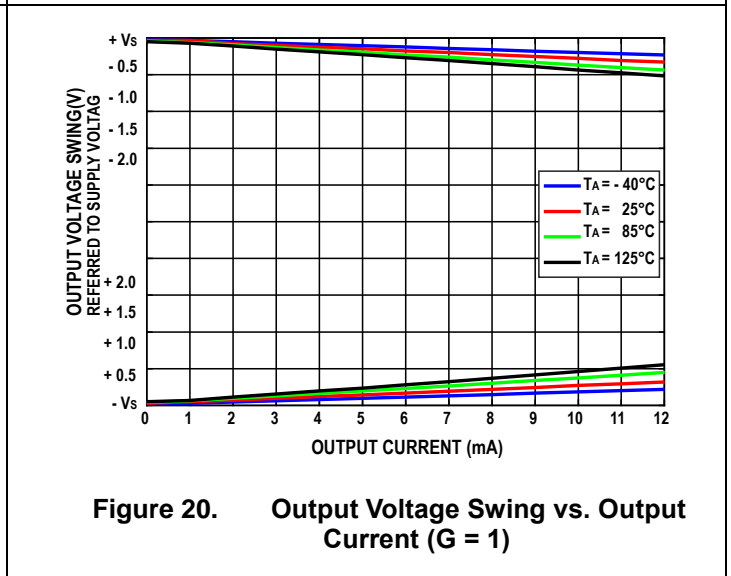
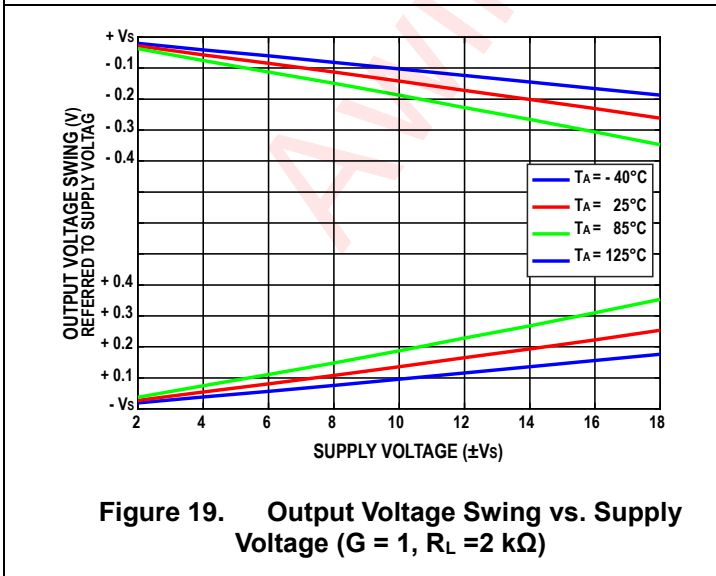
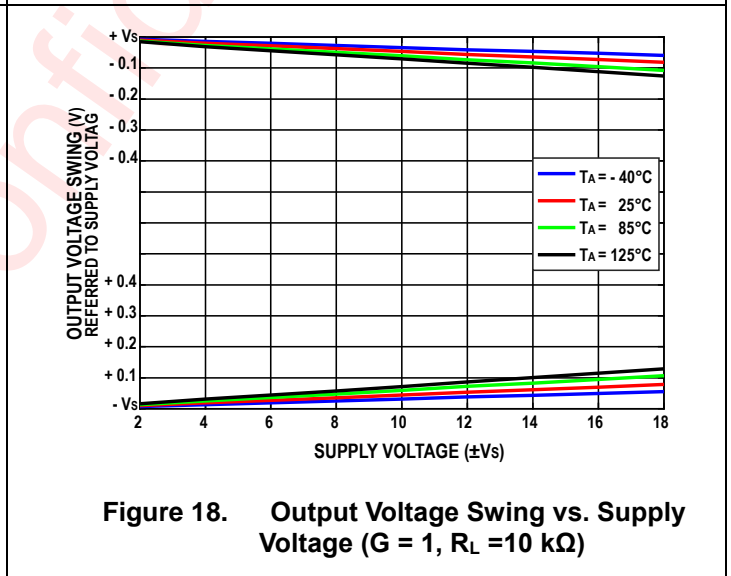
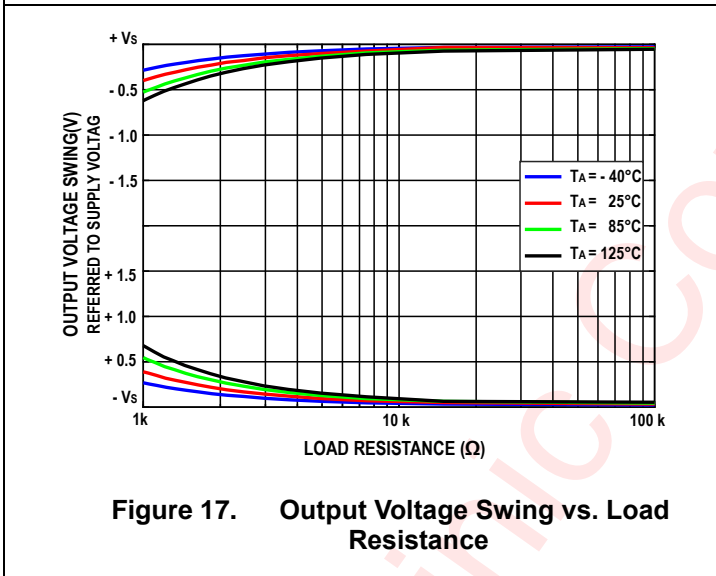
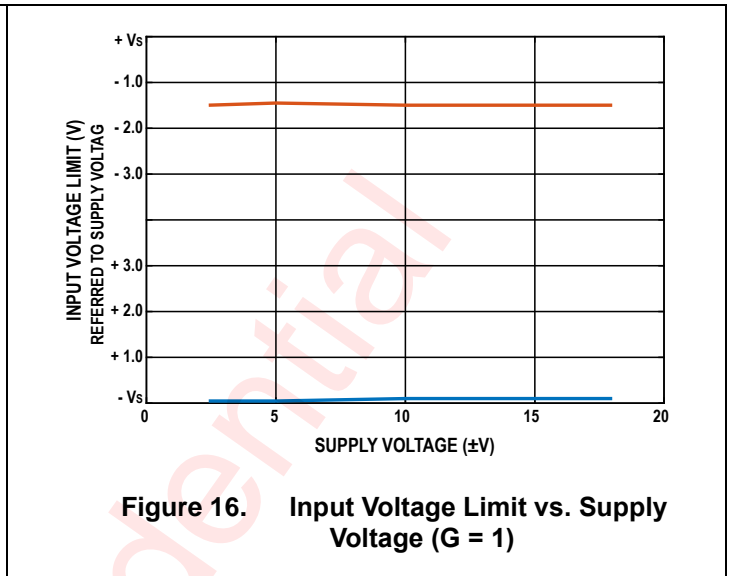
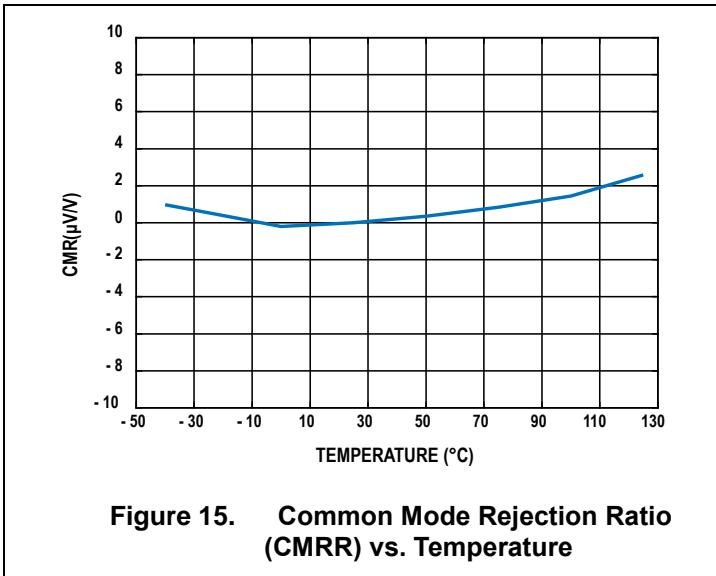

Figure 14. Common Mode Rejection Ratio (CMRR) vs. Frequency (RTI)

Typical Characteristics(Continued)



Typical Characteristics(Continued)

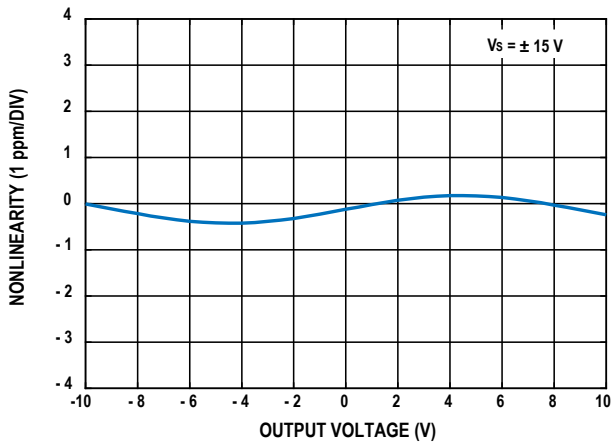

Figure 21. Gain Nonlinearity (G = 1,  $R_L = 10\text{ k}\Omega$ )

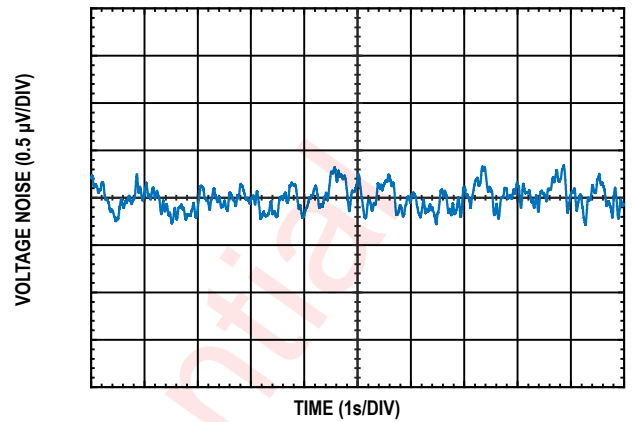

Figure 22. 0.1 Hz to 10 Hz RTI Voltage Noise (G = 100)

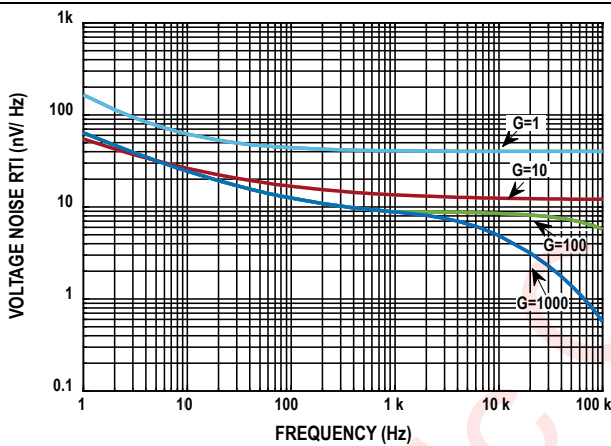

Figure 23. RTI Voltage Noise Spectral Density vs. Frequency (G = 1 to 1000)

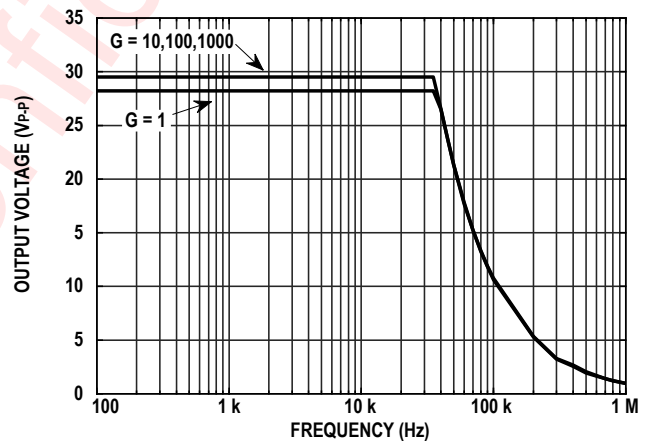

Figure 24. Large Signal Frequency Response

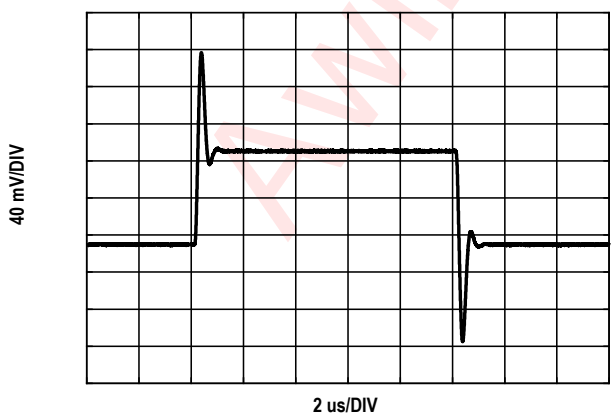

Figure 25. Small Signal Pulse Responses(G = 1,  $R_L = 2\text{ k}\Omega$ ,  $C_L = 100\text{ pF}$ )

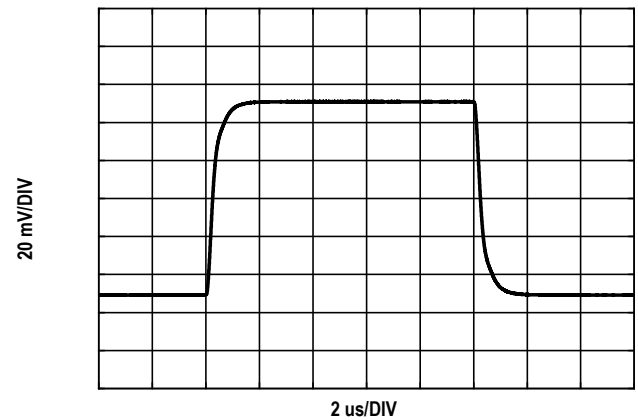

Figure 26. Small Signal Pulse Responses(G = 10,  $R_L = 2\text{ k}\Omega$ ,  $C_L = 100\text{ pF}$ )

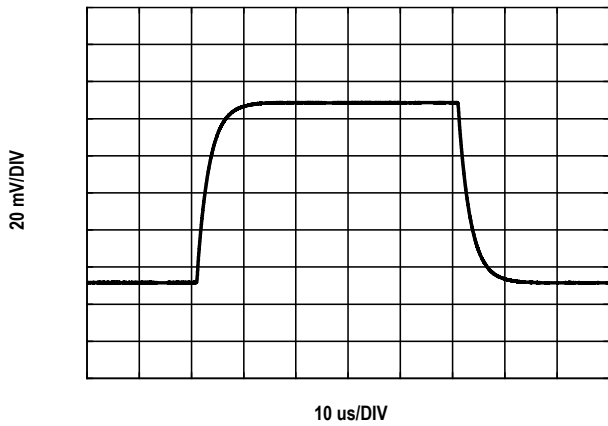

Figure 27. Small Signal Pulse Respons( $G = 100$ ,  $R_L = 2\text{ k}\Omega$ ,  $C_L = 100\text{ pF}$ )

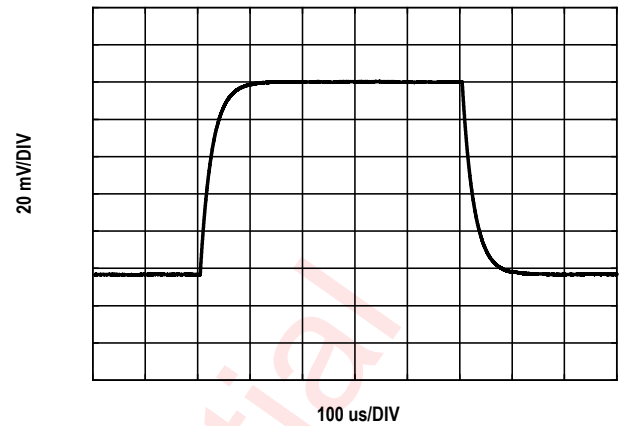
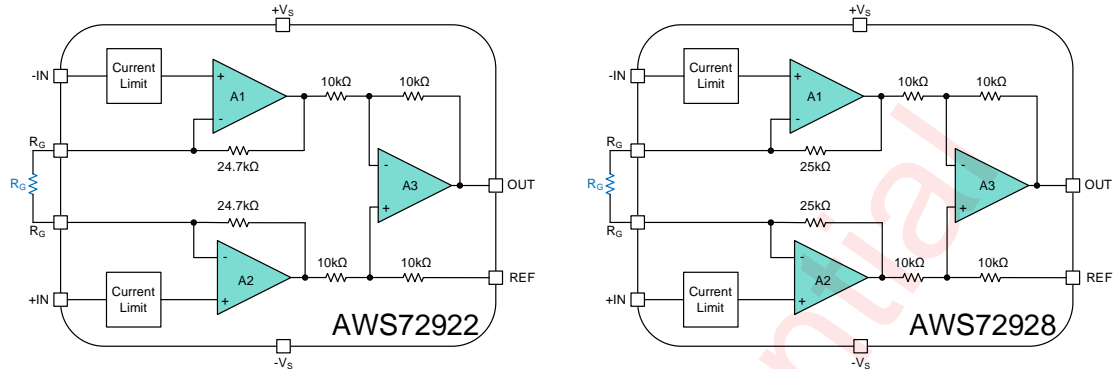

Figure 28. Small Signal Pulse Respons( $G = 1000$ ,  $R_L = 2\text{ k}\Omega$ ,  $C_L = 100\text{ pF}$ )

Awinic Confidential

## Detailed Functional Description

### Theory of Operation



**Figure 29. Simplified Schematic of AWS72922/AWS72928**

The AWS72922/AWS72928 is a monolithic instrumentation amplifier based on the classic 3-op amp topology. The input stage consists of amplifiers A1 and A2, two trimmed 24.7 kΩ or 25 kΩ resistors are integrated. They are used along with an external resistor  $R_G$ , to set the gain. The amplified differential and common-mode signals are applied to a difference amplifier that rejects the common-mode voltage but amplifies the differential voltage. The difference amplifier employs innovations that result in low output offset voltage as well as low output offset voltage drift. Trimming these resistors and amplifiers can achieve a highly accurate instrumentation amplifier with gain error less than 0.1% and CMRR exceeding 93 dB ( $G = 10$ ).

The AWS72922/AWS72928 offers extremely high input impedance, low  $I_B$  (below 500 pA at room temperature and symmetrical for IN+ and IN-), low  $I_B$  drift, low  $I_{OS}$  (lower than 1 nA from -40 °C to 85 °C), low input bias current noise, and extremely low voltage noise of  $8nV/\sqrt{Hz}$ .

The gain equation of the AWS72922 is

$$G = 1 + \frac{49.4 \text{ k}\Omega}{R_G}$$

The gain equation of the AWS72928 is

$$G = 1 + \frac{50 \text{ k}\Omega}{R_G}$$

Users can easily and accurately set the gain through a standard resistor.

### Gain Selection

Placing a resistor across the  $R_G$  terminals set the gain of AWS72922, which can be calculated by referring to Table 1 or by using the gain equation.

$$R_G = \frac{49.4 \text{ k}\Omega}{G - 1}$$

1 % Standard Table Value of $R_G$ ( $\Omega$ )	Calculated Gain
49.9 k	1.990
12.4 k	4.984
5.49 k	9.998
2.61 k	19.93
1.00 k	50.40
499	100.0
249	199.4
100	495.0
49.9	991.0

0.1 % Standard Table Value of $R_G$ ( $\Omega$ )	Calculated Gain
49.3 k	2.002
12.4 k	4.984
5.49 k	9.998
2.61 k	19.93
1.01 k	49.91
499	100.0
249	199.4
98.8	501.0
49.3	1003

Table 1. Commonly-Used Gains and Resistor Values

The AWS72922 defaults to  $G = 1$  when no gain resistor is used.

Placing a resistor across the  $R_G$  terminals set the gain of AWS72928, which can be calculated by referring to 0 or by using the gain equation.

$$R_G = \frac{50 \text{ k}\Omega}{G - 1}$$

1 % Standard Table Value of $R_G$ ( $\Omega$ )	Calculated Gain	0.1 % Standard Table Value of $R_G$ ( $\Omega$ )	Calculated Gain
49.9 k	2.002	49.9 k	2.002
12.4 k	5.032	12.4 k	5.032
5.62 k	9.897	5.56 k	9.993
2.61 k	20.16	2.64 k	19.94
1.02 k	50.02	1.02 k	50.02
511	98.85	505	100.0
249	201.8	252	199.4
100	501.0	100	501.0
49.9	1003	49.9	1003

Table 2. Commonly-Used Gains and Resistor Values

The AWS72928 defaults to  $G = 1$  when no gain resistor is used.

The gain that users can obtain in actual use is related to the corresponding resistance tolerance, so external gain resistors can be selected according to actual needs, as shown in Tables 1 and 2. In addition, the temperature characteristics of the gain setting resistor  $R_G$  directly affect the temperature characteristics of the entire system. In practical design, parasitic resistance caused by PCB wiring can also affect the accuracy of actual gain. To ensure better gain error, great attention should be paid to reducing parasitic resistance during wiring to obtain more accurate gain. It is usually recommended to choose precision resistors with a temperature coefficient better than 10 ppm/°C.

### Offset Voltage

Due to the fact that the offset voltage of AWS72922 and AWS72928 is composed of the input offset voltage  $V_{OSI}$  and the output offset voltage  $V_{OSO}$ .  $V_{OSI}$  includes the offset voltage generated by input amplifiers A1 and A2;  $V_{OSO}$  is the offset voltage of amplifier A3. Generally speaking, when the gain is high, the input offset voltage  $V_{OSI}$  occupies a larger proportion. When the gain is low, the output offset voltage  $V_{OSO}$  occupies a larger proportion. Users need to distinguish whether the offset voltage is for the input or output terminal. Assuming the gain is set to  $G$ , the input equivalent and output equivalent offset voltages are as follows:

$$\text{Total Error RTI } (V_{OS,RTI}) = V_{OSI} + \frac{V_{OSO}}{G}$$

$$\text{Total Error RTO } (V_{OS,RTO}) = G * V_{OSI} + V_{OSO}$$

### Input Bias Current Return Path

The input of a typical instrumentation amplifier is connected to a signal source with high output impedance. The bias current indicators of AWS72922 and AWS72928 are also very excellent, ensuring that they are within 0.5 nA at room temperature. However, some circuits (such as thermocouples and transformers) cannot provide a bias current circuit on their own, which can cause the circuit to malfunction. Figures 30 and 31 provide methods for solving such problems.

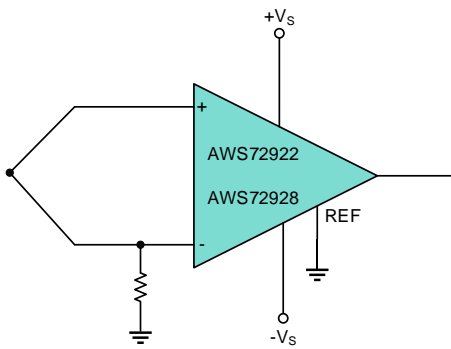

Figure 30.AWS72922/AWS72928 Interfaces  
with Thermocouple

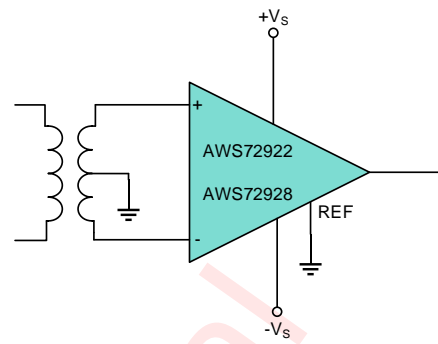

Figure 31.AWS72922/AWS72928  
Interfaces with Transformer

When using AWS72922/AWS72928 for AC coupling, it is important to provide a return path to the input AC coupling capacitors. Otherwise, the input offset voltage will accumulate due to parasitic leakage and input currents, potentially causing the output to lock to a fixed voltage near the power rail. Figure 32 shows the correct connection for AC coupling, which utilizes a high-pass filter with a cutoff frequency determined by RC. And due to the differential inputs, the matching of R and C is crucial.

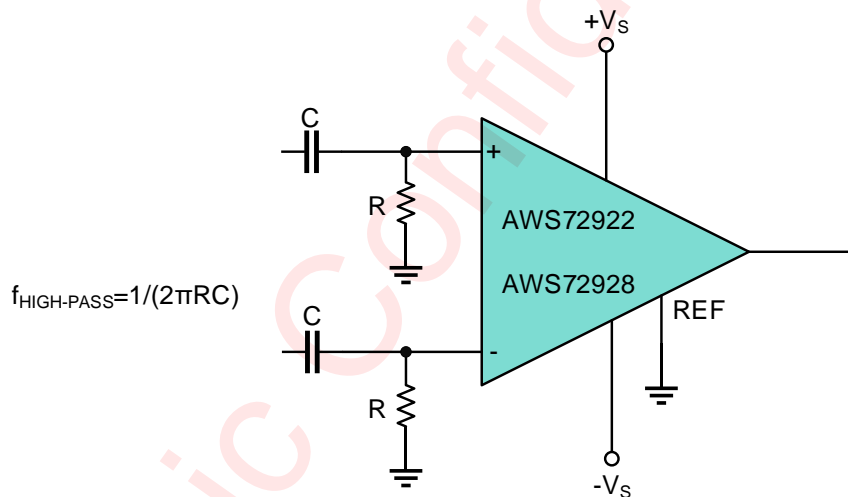

Figure 32.AWS72922/AWS72928 in AC Coupling Connection

### Input Protection

The AWS72922/AWS72928 features a 3 kV ESD rating in the Human Body Model (HBM). As shown in Figure 29, each input of the AWS72922/AWS72928 has a current-limit circuit, protecting both the device itself and the system.

For applications where the AWS72922/AWS72928 encounters extreme overload voltages, as in cardiac defibrillators, external series resistors, and low leakage diode clamps should be used. Please ensure that the distance between this diode and the input pin is as short as possible during layout.

### Reference Terminal

The reference terminal REF defines the zero-output voltage and is especially useful when the load does not share a precise ground with the rest of the system. It can interface with pseudo-differential input ADCs easily, for example, pseudo-differential unipolar and pseudo-differential bipolar.

The input range of the REF end can reach within 1.2 V of the power rail. As shown in Figure 29, the REF pin is directly connected to one end of the internally trimmed 10 kΩ resistor, and the output of the instrumentation amplifier is referenced to the voltage on the REF pin. When AWS72922/AWS72928 interfaces with ADC, which requires the output of the front-end circuit to be referenced to half of its supply voltage ( $V_{DD}/2$ ). In this case, an external  $V_{DD}/2$  source can be connected to the REF pin of AWS72922/AWS72928, which is very convenient.

Parasitic resistance should be kept to a minimum for optimum CMRR. To achieve the best performance, the REF pin should maintain a low source impedance, as parasitic resistance can adversely affect CMRR and gain accuracy. If the REF pin is not connected to a clean and low-impedance system ground, a precision op amp buffer (such as AWS72633) between the REF pin and the signal source is recommended to achieve the best performance.

### Power Supply Regulation and Bypassing

A stable dc voltage should be used to power the instrumentation amplifier. Noise on the supply pins can adversely affect performance. Bypass capacitors should be used to decouple the amplifier.

A low ESR 0.1 μF capacitor should be placed close to each supply pin. High-quality surface-mount ceramic capacitors (such as X5R or X7R) are recommended. As shown in Figure 33, a 10 μF tantalum capacitor can be used, and in most cases, it can be shared by other precision integrated circuits. Refer to the Layout Example section for specific layout examples.

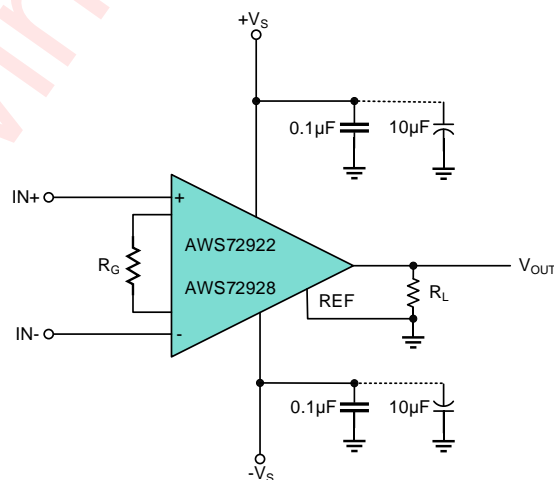

**Figure 33. Supply Decoupling, REF, and Output Referred to Local Ground**

Although the AWS72922/AWS72928 is a very reliable chip with certain protection functions, it is generally recommended to power on the AWS72922/AWS72928 before applying the input signals.

## Grounding

Star grounding is recommended for the AWS72922/AWS72928 circuit, as shown in Figure 33. Maintain low impedance for the REF pin because the output voltage of the AWS72922/AWS72928 is developed with respect to the potential on the REF. Place the decoupling capacitors as close to the power pins as possible to minimize the loop area.

In a multilayer PCB, use a large area ground plane if possible. Place analog signals on the layer above the ground plane.

In mixed-signal environments, low level analog signals need to be isolated from the noisy digital environment. Modern precision SAR ADCs have separate analog and digital ground, and they are all connected to the analog ground. When used with this type of ADC, the AWS72922/AWS72928 uses the analog ground as the reference.

The AWS72922/AWS72928 has a low bias current. To reduce leakage current, it is recommended to remove the ground plane below the signal traces of the two inputs. Refer to the Layout Examples section for specific examples.

## AWS72922/AWS72928 Comparison to Zero-drift Instrumentation Amplifiers

AWS72922/AWS72928 is a continuous-signal processing instrumentation amplifier, unlike chopping/auto-zero-based zero-drift amplifiers reliant on non-continuous switch-based technology. These amplifiers contain a sampling capacitor at the input, causing the input bias current to exhibit periodic glitches invisible in datasheets due to averaging. Eliminating these glitches requires an output filter, significantly limiting their usable bandwidth and often restricting them to DC and near-DC signals. Adding a filter also adds complexity to system design. Additionally, tolerance of their internal sampling capacitors leads to variations in glitch amplitude across different ICs. More critically, their linearity (THD & THD+N) is often not great. While they may boast better low-frequency noise, this comes at the cost of transferring noise to the switching frequency, resulting in a noisy spectrum with large spike components. Consequently, their overall noise performance is often inferior to high-performance continuous sampling amplifiers like the AWS72922/AWS72928.

Furthermore, the usable bandwidth of zero-drift amplifiers is typically only 1/10 or 1/100 of what their datasheets suggest, severely limiting their usability. Their settling time and overload recovery time are also often much longer, making them unsuitable for multi-channel switching or applications with dynamic performance requirements.

## Application Information

### Building Precision Current Source with AWS72922/AWS72928

Figure 34 illustrates the construction of a precision current source using a single AWS72922/AWS72928 instrumentation amplifier, one AWS7263X precision operational amplifier and two resistors. This design offers flexibility with a supply voltage range of  $\pm 2.4\text{ V}$  to  $\pm 18\text{ V}$ . The AWS72922/AWS72928's characteristics simplify setting the circuit's current output. The actual current output is equal to the set value minus the input bias current of the AWS7263X, which is within 25 pA at room temperature, making it often negligible.

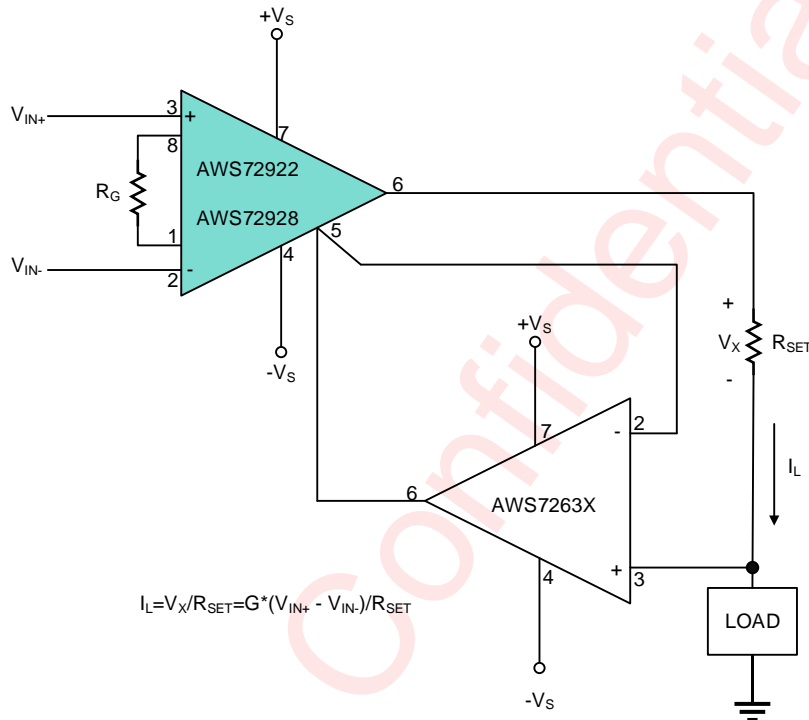

Figure 34. Building Precision Current Source with AWS72922/AWS72928

### Precision Current Sensing

The AWS72922/AWS72928 is often used for precision current sensing due to its high accuracy, wide bandwidth, low input bias current, and ease of use. As shown in Figure 35, the shunt resistor  $R_s$  is typically low, possibly a few Ohms, or even in the  $m\Omega$  range. The AWS72922/AWS72928's high input impedance and input bias current of 0.5nA or less allow it to detect currents as low as 5 nA, its low-frequency noise of  $0.9\ \mu\text{V}_{\text{P-P}}$  allows it to detect  $\mu\text{V}$ -level signals. The AWS72922/AWS72928 has a wide input range, allowing it to accurately measure input signals with a large dynamic range from  $\mu\text{V}$  to several volts. In general, current changes rapidly, so the AWS72922/AWS72928's wide bandwidth is very suitable. This is particularly beneficial in applications like motor control or battery monitoring, where current can fluctuate rapidly. On the other hand, the voltage  $V_m$  can be a high voltage varying at a certain frequency. In this case, the AWS72922/AWS72928's high CMRR is critical for accuracy. The AWS72922/AWS72928's CMRR performance with frequency is very good, with a several-fold improvement over traditional pin-out instrumentation amplifiers. This meets the new current sensing requirements of many emerging industries. For example, with the adoption of renewable energies, the frequency of current and voltage has increased. To maintain the same detection accuracy, the CMRR of the instrumentation amplifier must also be increased with frequency. The characteristics of the AWS72922/AWS72928 meet this new requirement, enabling systems to meet requirements without modifying hardware, which greatly accelerates the product iteration speed.

For applications that require long-term operation and large environmental temperature changes, the AWS72922/AWS72928's long-term stability and temperature drift characteristics are very valuable, making the design simpler and more reliable.

In some applications, the signal dynamic range is too big, and the accuracy or linearity of the instrumentation amplifier must be sacrificed by changing  $R_G$  to meet the needs of measuring the entire dynamic range. In this case, using digital potentiometers is not a good solution, because their temperature characteristics are often not very good. Engineers may consider the series and parallel connection of precision resistors, utilizing relays with good temperature characteristics to switch between ranges. Attention should be paid to wiring in such configurations.

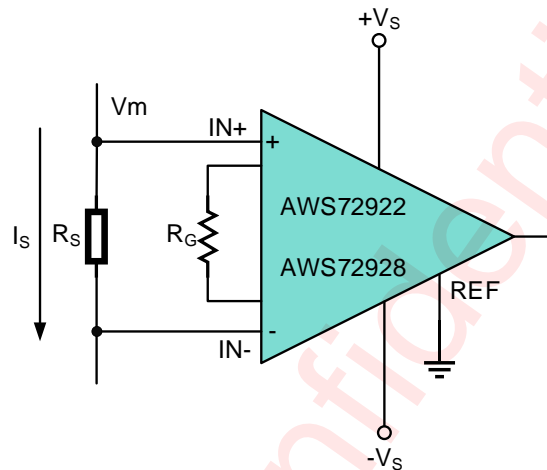

**Figure 35. Using AWS72922/AWS72928 for Precision Current Sensing**

In precision current sensing, if a zero-drift instrumentation amplifier is used, the offset voltage caused by bias current glitch and high-frequency noise will limit the minimum detectable current, thereby limiting the detection accuracy. The available bandwidth of a zero-drift instrumentation amplifier is typically 1/10 to 1/100 of its data sheet bandwidth, which limits the available bandwidth of the current to be measured. This can often make it difficult to keep up with fast-changing currents, resulting in missed information or limiting the bandwidth of closed-loop systems. The longer settling time and lower slew rate of zero-drift instrumentation amplifiers will reduce the system's response speed. The poor linearity of zero-drift instrumentation amplifiers can make the design of control systems difficult or even impossible.

## PCB Layout Consideration

For best operational performance of the device, use good PCB layout practices, including:

1. Noise can propagate into analog circuitry through the power pins of the circuit as a whole and op amp itself. Bypass capacitors are used to reduce the coupled noise by providing low-impedance power sources local to the analog circuitry. Connect low-ESR, 0.1- $\mu\text{F}$  ceramic bypass capacitors between each supply pin and ground, placed as close to the device as possible. A single bypass capacitor from  $+V_S$  to ground is applicable for single-supply applications.
2. Separate grounding for analog and digital portions of circuitry is one of the simplest and most-effective methods of noise suppression. One or more layers on multilayer PCBs are usually devoted to ground planes. A ground plane helps distribute heat and reduces EMI noise pickup. Make sure to physically separate digital and analog grounds paying attention to the flow of the ground current.
3. In order to reduce parasitic coupling, run the input traces as far away from the supply or output traces as possible. If these traces cannot be kept separate, crossing the sensitive trace perpendicular is much better as opposed to in parallel with the noisy trace.
4. Place the external components as close to the device as possible. As illustrated in Figure 37, keeping  $R_F$ ,  $R_G$  and  $C_F$  close to the inverting input minimizes parasitic capacitance.
5. Keep the length of input traces as short as possible. Always remember that the input traces are the most sensitive part of the circuit.
6. Consider a driven, low-impedance guard ring around the critical traces. A guard ring can significantly reduce leakage currents from nearby traces that are at different potentials.
7. Cleaning the PCB following board assembly is recommended for best performance.
8. Any precision integrated circuit may experience performance shifts due to moisture ingress into the plastic package. Following any aqueous PCB cleaning process, baking the PCB assembly is recommended to remove moisture introduced into the device packaging during the cleaning process. A low temperature, post cleaning bake at 85°C for 30 minutes is sufficient for most circumstances.

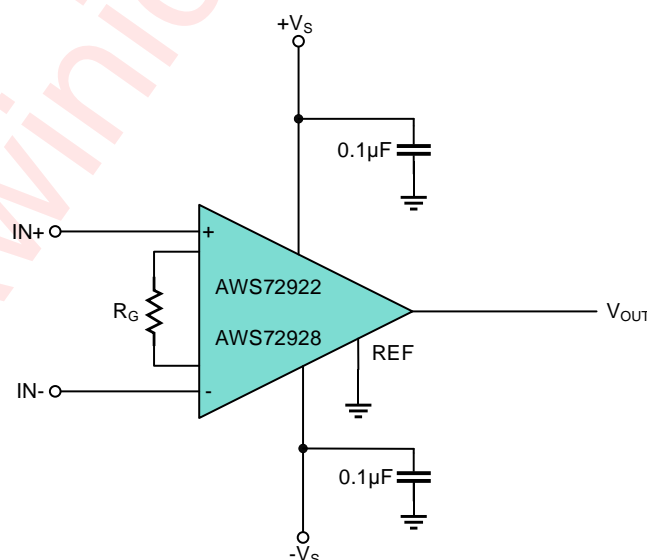

Figure 36. AWS72922/AWS72928 Schematic Example

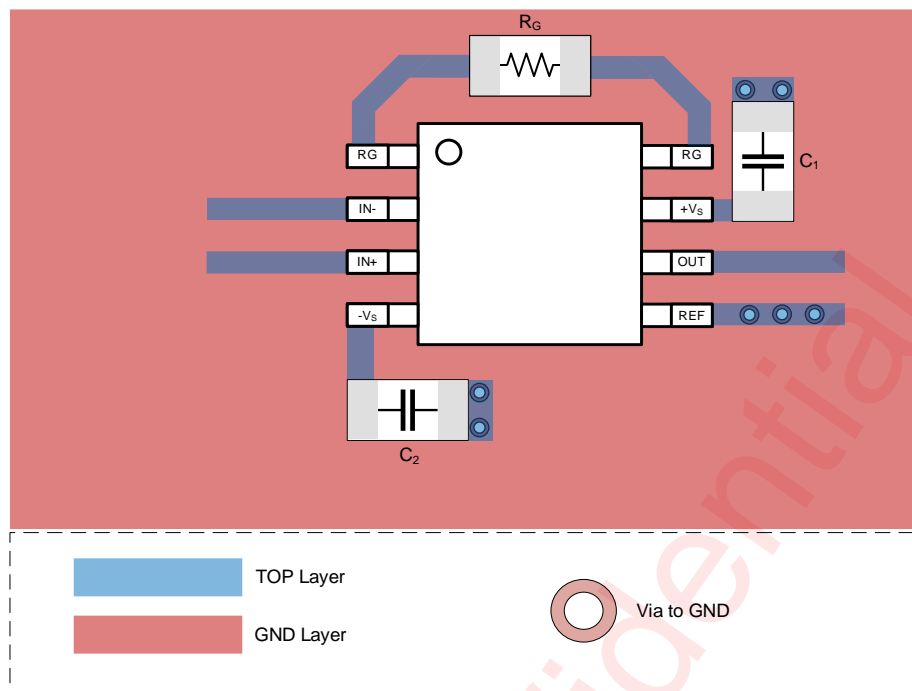
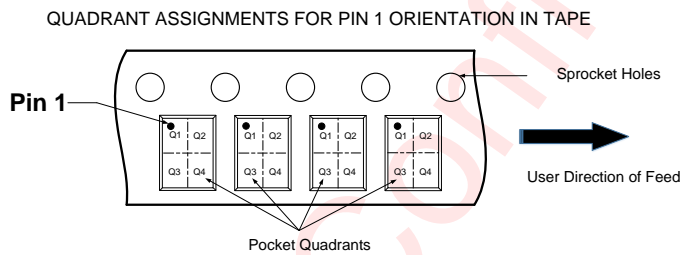
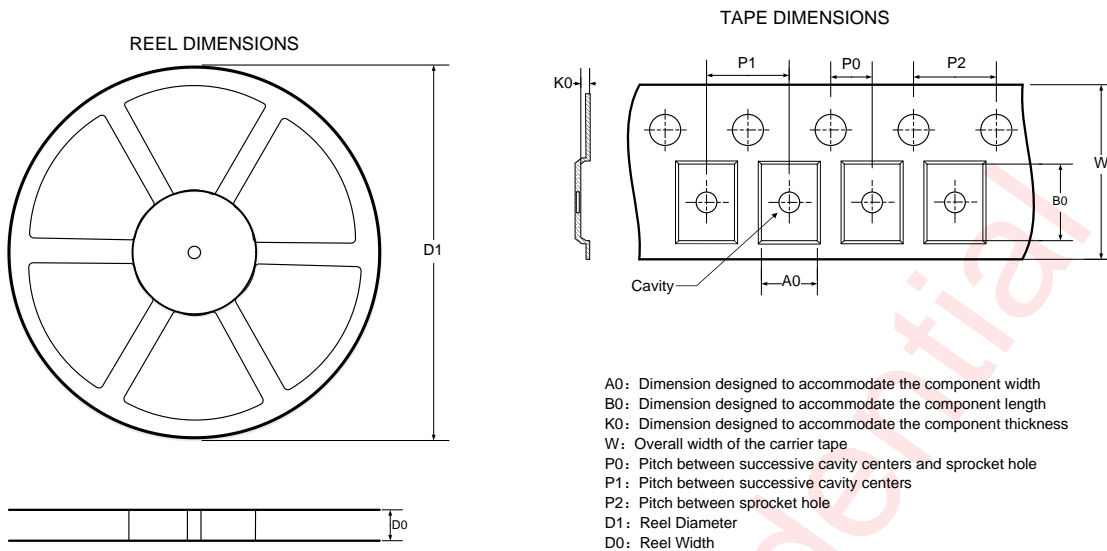

Figure 37.AWS72922/AWS72928 Layout Example

## Tape And Reel Information



Note: The above picture is for reference only. Please refer to the value in the table below for the actual size

DIMENSIONS AND PIN1 ORIENTATION

D1 (mm)	D0 (mm)	A0 (mm)	B0 (mm)	K0 (mm)	P0 (mm)	P1 (mm)	P2 (mm)	W (mm)	Pin1 Quadrant
330.00	12.00	6.50	5.20	2.00	2.00	8.00	4.00	12.00	Q1

All dimensions are nominal

Package Description

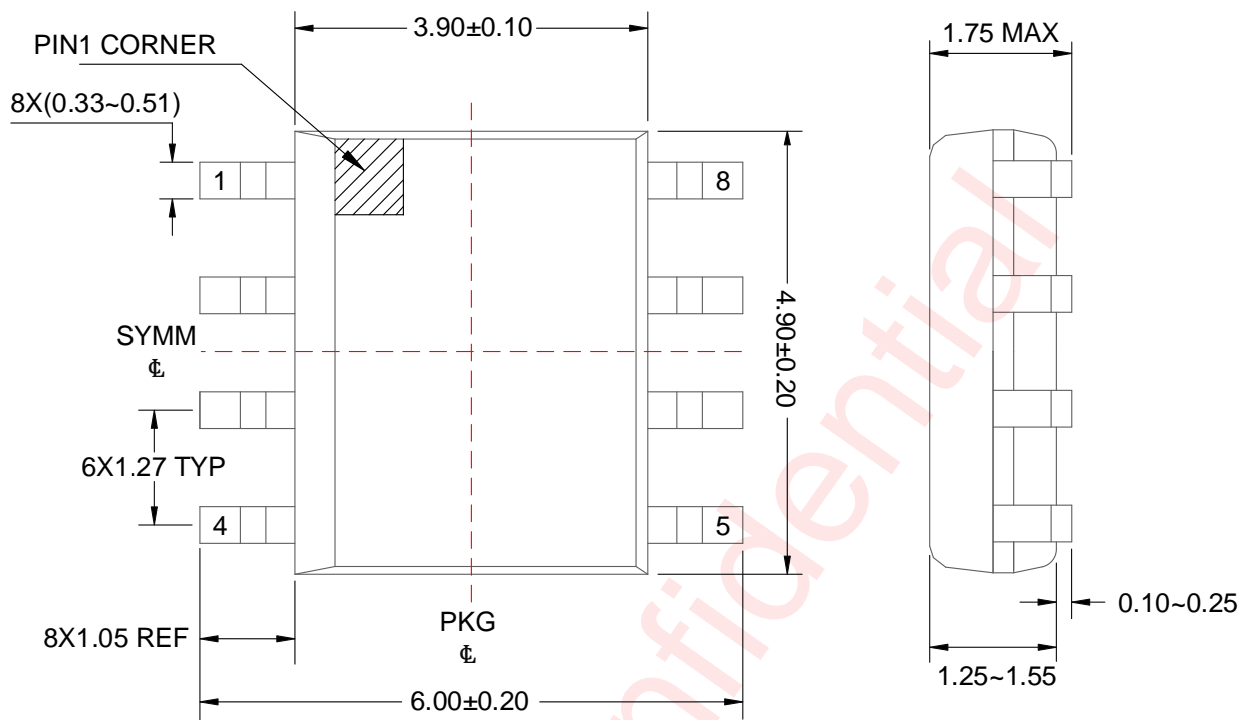

Top View

Side View

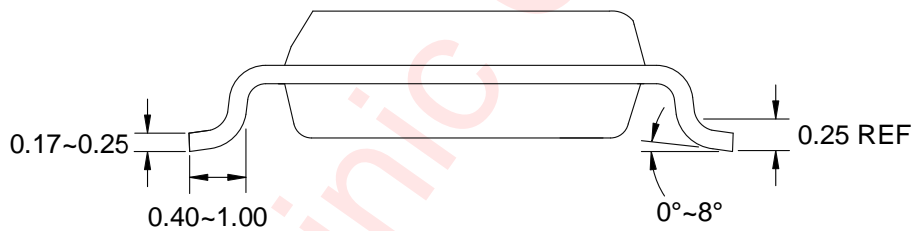

Side View

Unit: mm

Land Pattern Data

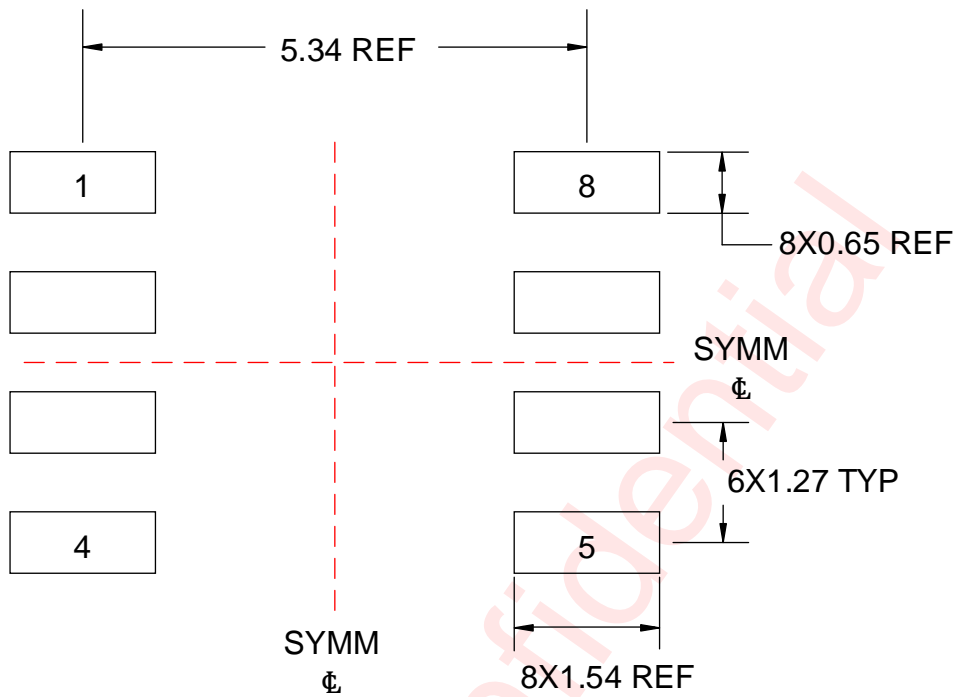

0.05 MAX  
All AROUND

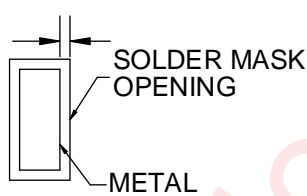

NON SOLDER MASK DEFINED

0.05 MIN  
All AROUND

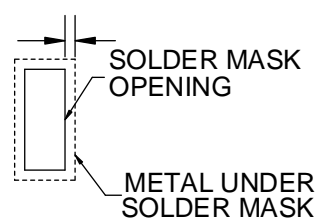

SOLDER MASK DEFINED

Unit: mm

## Revision History

Version	Date	Change Record
V1.0	May 2025	Official released

Awinic Confidential

## Disclaimer

Information in this document is believed to be accurate and reliable. However, Shanghai AWINIC Technology Co., Ltd (AWINIC Technology) does not give any representations or warranties, expressed or implied, as to the accuracy or completeness of such information and shall have no liability for the consequences of use of such information.

AWINIC Technology reserves the right to make changes to information published in this document, including without limitation specifications and product descriptions, at any time and without notice. Customers shall obtain the latest relevant information before placing orders and shall verify that such information is current and complete. This document supersedes and replaces all information supplied prior to the publication hereof.

AWINIC Technology products are not designed, authorized or warranted to be suitable for use in medical, military, aircraft, space or life support equipment, nor in applications where failure or malfunction of an AWINIC Technology product can reasonably be expected to result in personal injury, death or severe property or environmental damage. AWINIC Technology accepts no liability for inclusion and/or use of AWINIC Technology products in such equipment or applications and therefore such inclusion and/or use is at the customer's own risk.

Applications that are described herein for any of these products are for illustrative purposes only. AWINIC Technology makes no representation or warranty that such applications will be suitable for the specified use without further testing or modification.

All products are sold subject to the general terms and conditions of commercial sale supplied at the time of order acknowledgement.

Nothing in this document may be interpreted or construed as an offer to sell products that is open for acceptance or the grant, conveyance or implication of any license under any copyrights, patents or other industrial or intellectual property rights.

Reproduction of AWINIC information in AWINIC data books or data sheets is permissible only if reproduction is without alteration and is accompanied by all associated warranties, conditions, limitations, and notices. AWINIC is not responsible or liable for such altered documentation. Information of third parties may be subject to additional restrictions.

Resale of AWINIC components or services with statements different from or beyond the parameters stated by AWINIC for that component or service voids all express and any implied warranties for the associated AWINIC component or service and is an unfair and deceptive business practice. AWINIC is not responsible or liable for any such statements.