

Adjustable Current-Limit Load Switch with OVP

Features

- V_{IN} : 2.7~5.5V
- 28V Absolute Rating at V_{OUT}
- 2.5A Continuous Current Capability
- Adjustable Current Limit: 0.1A~2.5A (Typ.)
 - 0.5A~2.5A with 7% Accuracy
 - <0.5A with 10% Accuracy
 - <0.3A with 15% Accuracy
- R_{on} : 80m Ω (Typ.)
- Soft-start
- Output OVP: Typ.=5.8V
- No Output Discharge During Off State
- Open-Drain over-current fault flag
- Thermal Shutdown
- Under-Voltage Lockout (UVLO)
- True Reverse-Current Blocking (TRCB)
- Shut-Down Supply Current: 0.5 μ A
- FCQFN 1.2mm \times 1.2mm-9L package

General Description

AW35061 is a current-limiting protection switch, 80m Ω (Typ.), low resistance MOSFET switch intended to be inserted between a power source and a load to isolate and protect against abnormal voltage and current conditions. The input operating voltage range is between 2.7V to 5.5V. The output terminal is rated 28V absolute maximum.

The internal soft-start circuit controls inrush current due to highly capacitive loads. The device features very low quiescent current. The supply current reduces to 0.5 μ A in shut-down state.

The AW35061 has True Reverse-Current Blocking (TRCB) protection to avoid undesired reverse current from output to its input in either enabled or disabled states.

The AW35061 also features several additional protection functions, such as output over-voltage (OVP) and input under-voltage protection (UVLO), plus over-current (with Fault-flag) and thermal protection.

Applications

- Smart Phone, Tablet PCs
- Mobile Internet Devices

Typical Application Circuit

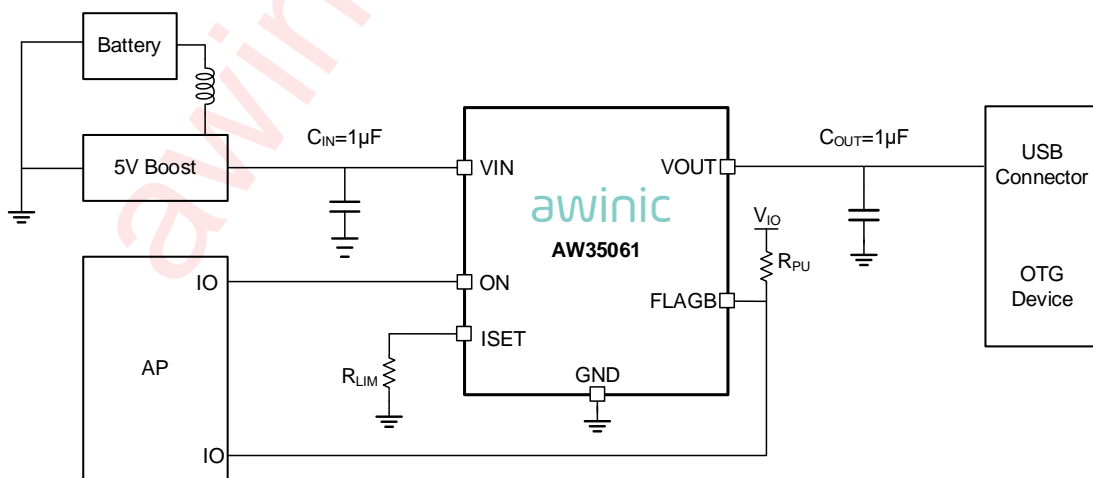

Figure 1 Typical Application Circuit of AW35061

Pin Configuration and Top Mark

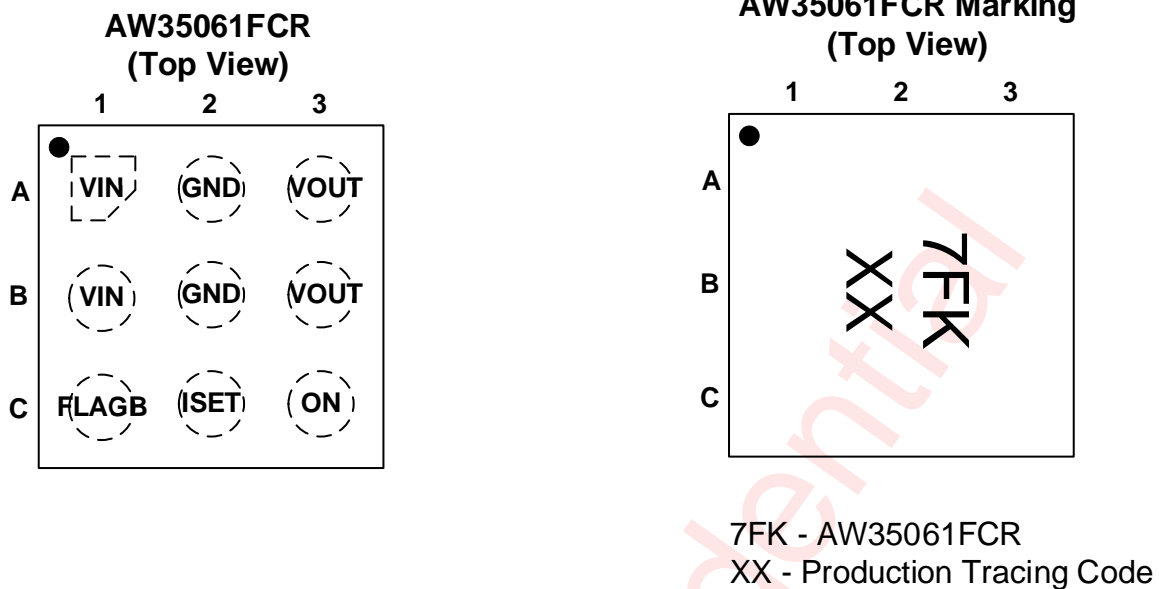

Figure 2 Pin Configuration and Top Mark

Pin Definition

Pin	Name	Description		
A3, B3	VOUT	Switch output		
A1, B1	VIN	Supply Input: Input to the power switch		
A2, B2	GND	Ground		
C3	ON	Logic Enable Control: Active HIGH-GPIO compatible	Logic HIGH	Enable Operation
			Logic LOW	Disable Operation
C1	FLAGB	Fault Output: Active Low, open-drain output that indicates an input over current. External pull-up resistor of greater than 10k is recommended		
C2	ISET	Current Limit Set Input: A resistor from ISET to ground sets the current limit for the switch		

Functional Block Diagram

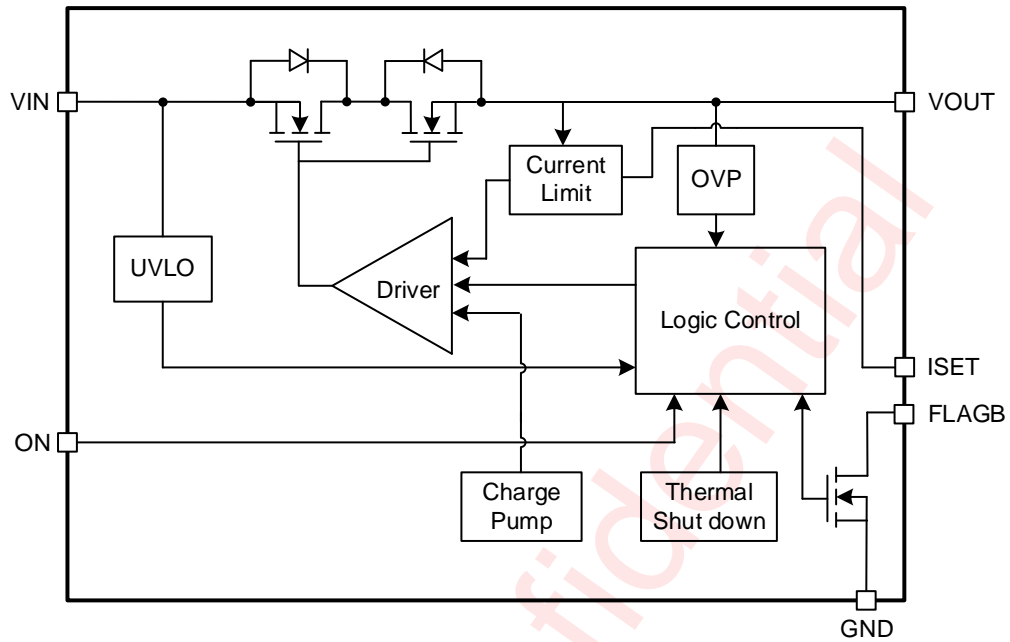

Figure 3 Functional Block Diagram

Typical Application Circuits

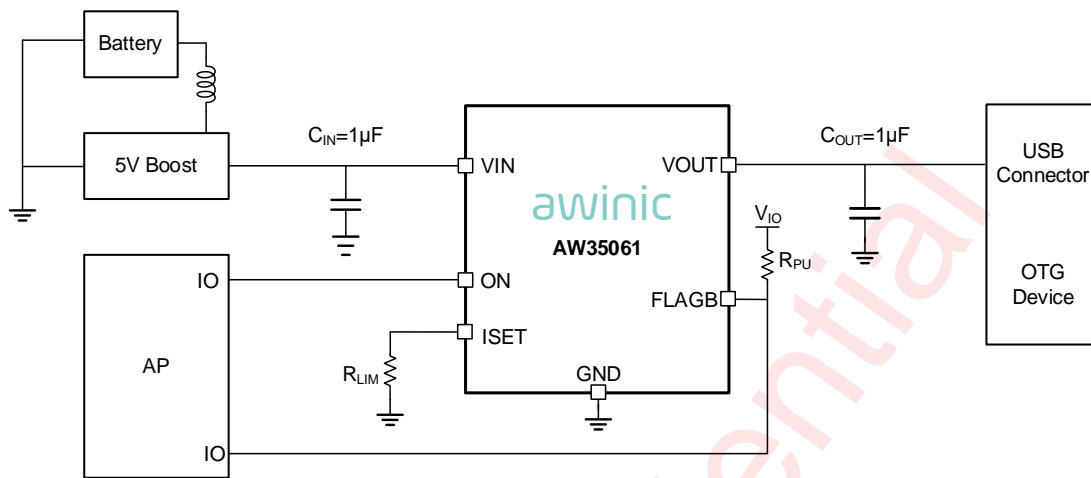

Figure 4 AW35061 Application circuit

Notice for Typical Application Circuits:

1. If VOUT is required external TVS, the maximum clamping voltage of the TVS should be below 28V.
2. If R_{LIM} is used to adjust the OCP threshold, connected between the ISET and GND pins. it is better to use 1% precision resistors to improve the OCP threshold precision. **ISET pin cannot be left floating.**
3. If FLAGB is used, R_{PU} is more than 10KΩ, If FLAGB is not used, it can be left floating, or short to GND.
4. C_{IN} = 1µF is recommended for typical application, larger C_{IN} is also acceptable.
5. C_{OUT} minimum is recommended to be 1µF. The rated voltage of C_{OUT} should be larger than the TVS clamping voltage. For example, the rated voltage of C_{OUT} is 50V.

Ordering Information

Part Number	Temperature	Package	Marking	Moisture Sensitivity Level	Environmental Information	Delivery Form
AW35061FCR	-40°C ~ 85°C	FCQFN 1.2mm×1.2mm -9L	7FK	MSL1	ROHS+HF	4500 units/ Tape and Reel

Absolute Maximum Ratings ^(NOTE 1)

PARAMETERS	RANGE
V_{IN}	-0.3V to 6.0V
ON	-0.3V to 6.0V
I_{SET}	-0.3V to 6.0V
FLAGB	-0.3V to 6.0V
V_{OUT}	-0.3V to 28.0V
I_{SW}	3A
t_{PD}	1W
$R_{\theta JA}$	90°C/W
Operating free-air temperature range	-40°C to 85°C
Maximum operating junction temperature T_{JMAX}	150°C
Storage temperature T_{STG}	-65°C to 150°C
Lead temperature (soldering 10 seconds)	260°C

NOTE1: Conditions out of those ranges listed in “absolute maximum ratings” may cause permanent damages to the device. In spite of the limits above, functional operation conditions of the device should within the ranges listed in “recommended operating conditions”. Exposure to absolute-maximum-rated conditions for prolonged periods may affect device reliability

NOTE2: Thermal resistance from junction to ambient is highly dependent on PCB layout

ESD Rating and Latch Up

PARAMETERS	VALUE	UNIT
HBM (Human Body Model) ^(NOTE 3)	±2	kV
CDM ^(NOTE 4)	±1.5	kV
Latch-Up ^(NOTE 5)	+IT: 200 -IT: -200	mA

NOTE3: The human body model is a 100pF capacitor discharged through a 1.5kΩ resistor into each pin. Test method: ESDA/JEDEC JS-001-2017

NOTE4: Test method: ESDA/JEDEC JS-002-2018

NOTE5: Test method: JESD78E

Electrical Characteristics

Unless otherwise noted, $V_{IN}=2.7$ to $5.5V$, $T_A = -40^{\circ}C$ to $85^{\circ}C$, Typical values are at $V_{IN} = 5V$ and $T_A = 25^{\circ}C$.

PARAMETER		TEST CONDITION	MIN	TYP	MAX	UNIT
BASIC OPERATION						
V_{IN}	Input Voltage		2.7		5.5	V
$I_{Q(OFF)}$	Off Supply Current	$V_{IN}=5V$, $V_{OUT}=\text{Open}$ $V_{ON}=\text{GND}$, $T_A = 25^{\circ}C$		0.5	4.0	μA
$I_{SD(OFF)}$	Shutdown Current	$V_{IN}=5V$, $V_{OUT}=0V$, $V_{ON}=\text{GND}$, $T_A = 25^{\circ}C$		0.5	4.0	μA
I_Q	Quiescent current into V_{IN} pin	$I_{OUT}=0$, $T_A = 25^{\circ}C$		165	240	μA
$R_{DS(ON)}$	On resistance	$V_{IN}=5V$, $I_{OUT}=1A$, $T_A = 25^{\circ}C$		80	110	m Ω
		$V_{IN}=3.7V$, $I_{OUT}=1A$, $T_A = 25^{\circ}C$		82	112	m Ω
V_{IH}	ON Input Logic HIGH Voltage	$V_{IN}=2.7V$ to $5.5V$	0.9			V
V_{IL}	ON Input Logic LOW Voltage	$V_{IN}=2.7V$ to $5.5V$			0.4	V
V_{IL_FLAG}	FLAGB Output Logic LOW Voltage	$V_{IN}=5V$, $I_{SINK}=1mA$		0.05	0.1	V
		$V_{IN}=2.7V$, $I_{SINK}=1mA$		0.06	0.15	V
I_{FLAGB_LK}	FLAGB Output Logic HIGH Leakage Voltage	$V_{IN}=5V$, Switch On			1.0	μA
I_{ON}	ON Input Leakage	$V_{ON} = 0V$ to V_{IN}			1.0	μA
R_{ON_PD}	Pull-Down Resistance at ON Pin			14		M Ω
OVER-VOLTAGE PROTECTION						
V_{OVP_TRIP}	Output OVP Lockout	Rising Threshold		5.8		V
		Falling Threshold		5.5		V
OUT_{HYS}	Output OVP Hysteresis			0.3		V
t_{OVP}	OVP Response	$I_{OUT}=0.5A$, $C_L=1\mu F$, $T_A=25^{\circ}C$, V_{OUT} from $5.5V$ to $6.0V$		100		ns
UNDER-VOLTAGE LOCK OUT						
V_{UVLO}	Under voltage lock out	V_{IN} Increasing		2.5		V
		V_{IN} Decreasing		2.3		V
V_{UVLO_HYS}	UVLO Hysteresis			200		mV

Electrical Characteristics (Continued)

Unless otherwise noted, $V_{IN}=2.7$ to $5.5V$, $T_A = -40^{\circ}C$ to $85^{\circ}C$ Typical values are at $V_{IN} = 5V$ and $T_A = 25^{\circ}C$.

PARAMETER	TEST CONDITION	MIN	TYP	MAX	UNIT	
OVER-CURRENT PROTECTION						
I_{LIM}	Current Limit	$V_{IN}=5V, R_{LIM}=400\Omega,$ V_{OUT} from 5V to 4.6V	2.33	2.5	2.67	A
		$V_{IN}=5V, R_{LIM}=1K\Omega$ V_{OUT} from 5V to 4.6V	0.93	1.0	1.07	A
		$V_{IN}=5V, R_{LIM}=2K\Omega$ V_{OUT} from 5V to 4.6V	465	500	535	mA
		$V_{IN}=5V, R_{LIM}=10K\Omega$ V_{OUT} from 5V to 4.6V	85	100	115	mA
t_{HOCP}	Hard Over-Current Response Time	Moderate Over-Current Condition, $I_{OUT} \geq I_{LIM}$, $V_{OUT} = 0$		1		μs
t_{OCP}	Over-Current Response Time	Moderate Over-Current Condition, $I_{OUT} \geq I_{LIM}$, $V_{OUT} \leq V_{IN}$		7		μs
t_{OC_FLAG}	Over-Current Flag Response Time	When Over-Current Occurs to Flag Pulling LOW		7		ms
TURE REVERSE CURRENT PROTECTION						
I_{RCB}	RCB Current	$V_{ON}=0V, V_{OUT}=5.5V, T_A = 25^{\circ}C$		10	20	μA
V_{T_RCB}	RCB Protection Trip Point	$V_{OUT}-V_{IN}, T_A = 25^{\circ}C$		50	90	mV
V_{R_RCB}	RCB Protection Release Trip Point	$V_{IN}-V_{OUT}, T_A = 25^{\circ}C$		50	90	mV
t_{RCB}	Default RCB Response Time	$V_{IN}=5V, V_{ON}=High$, From $V_{OUT} > V_{IN} + 50mV$ to $I_{OUT\ max}$		5		μs
THERMAL SHUTDOWN						
t_{SD}	Thermal shutdown	Shutdown		155		$^{\circ}C$
		Return from Shutdown		135		
		Hysteresis		20		
DYNAMIC CHARACTERISTICS						
t_{DON}	Turn-On Delay	$V_{IN}=5V, R_{LOAD}=100\Omega, C_L=1\mu F,$ $T_A=25^{\circ}C, R_{LIM}=2040\Omega$		0.76		ms
t_R	V_{OUT} Rise Time			0.48		ms
t_{ON}	Turn-On Time			1.24		ms
t_{DOFF}	Turn-Off Delay			15		ms
t_F	V_{OUT} Fall Time			0.23		ms
t_{OFF}	Turn-Off Time			0.245		ms

Timing Diagrams

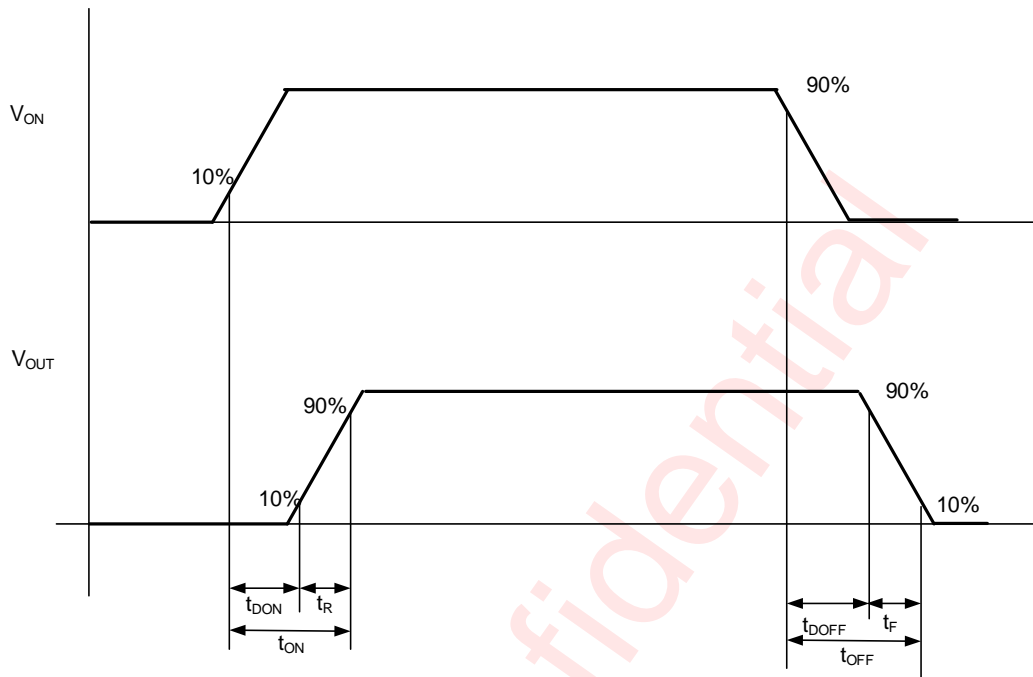

Figure 5 AW35061 Timing Diagrams

Typical Characteristics

Unless otherwise noted, $V_{IN}=2.7$ to $5.5V$, $T_A = -40^{\circ}C$ to $85^{\circ}C$, Typical values are at $V_{IN} = 5V$ and $T_A = 25^{\circ}C$.

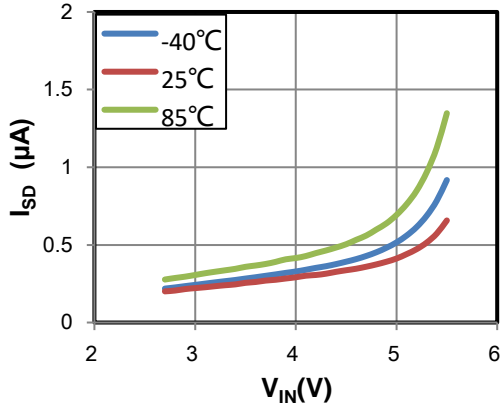

Figure 6 Shutdown Current vs. V_{IN}

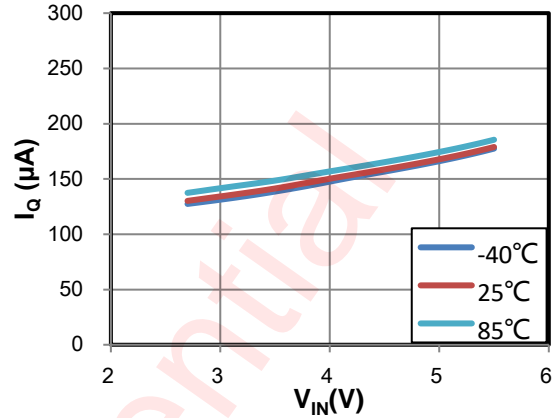

Figure 7 Quiescent Current vs. V_{IN}

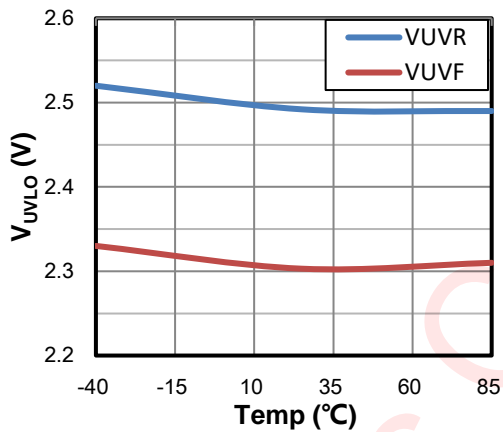

Figure 8 UVLO Threshold Voltage vs. Temperature

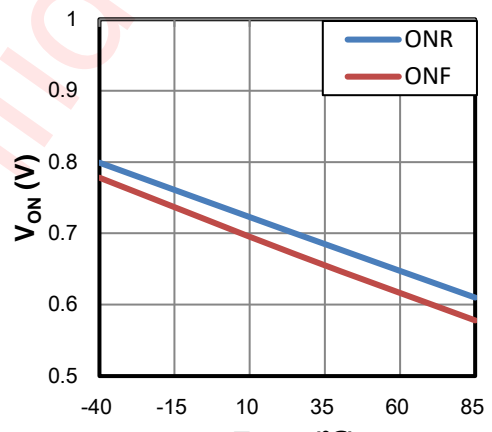

Figure 9 ON Threshold Voltage vs. Temperature

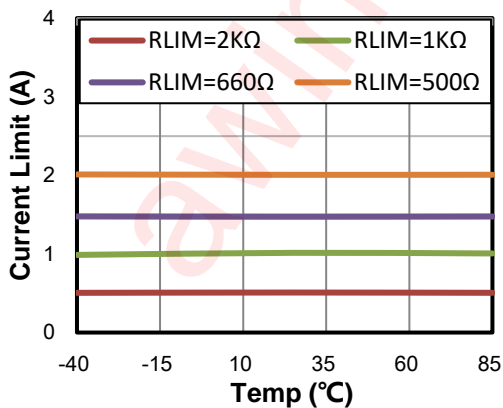

Figure 10 Current Limit Threshold vs. Temperature

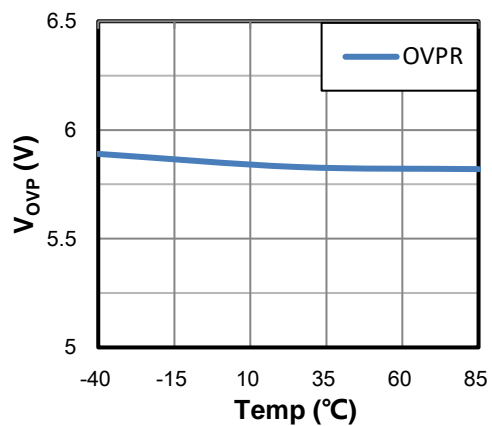

Figure 11 OVP Threshold Voltage vs. Temperature

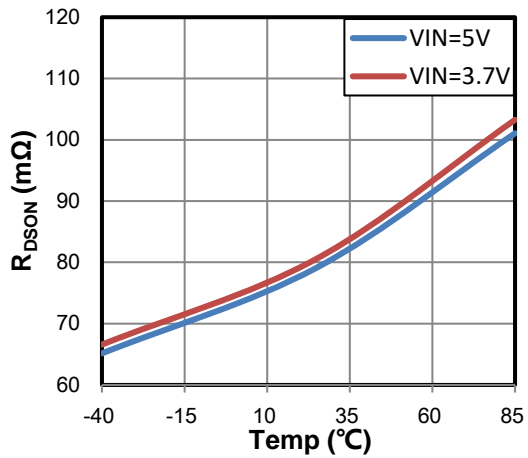

Figure 12 $R_{DS(on)}$ vs. Temperature

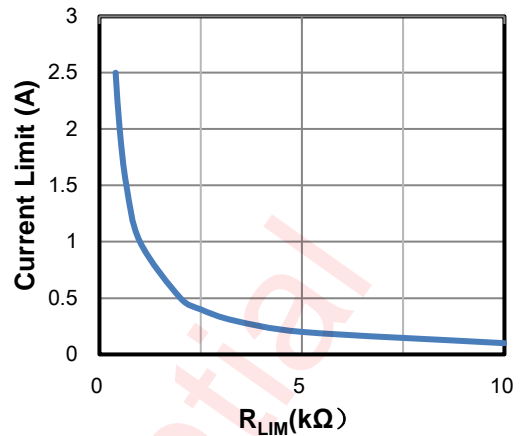

Figure 13 Current Limit Threshold vs. R_{LIM}

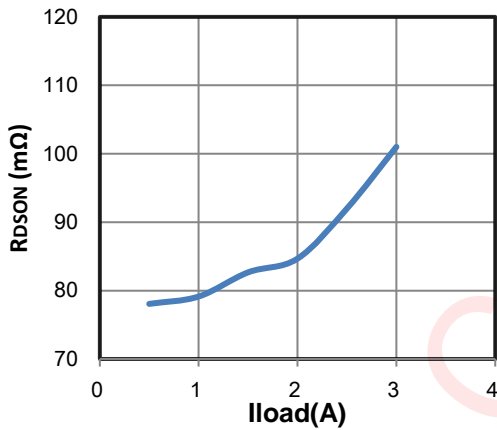

Figure 14 $R_{DS(on)}$ vs. I_{load}

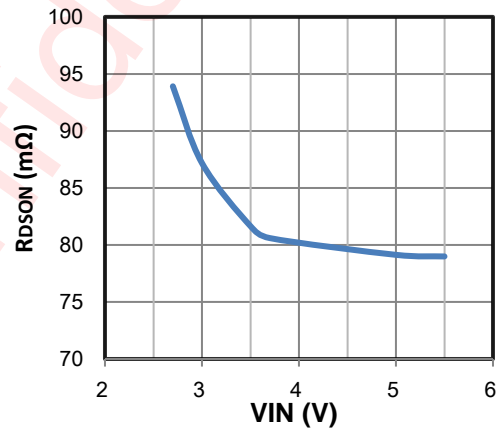

Figure 15 $R_{DS(on)}$ vs. V_{IN}

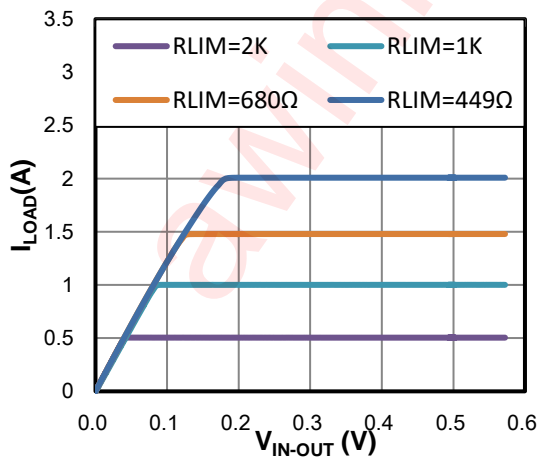

Figure 16 I_{LOAD} vs. V_{IN-OUT}

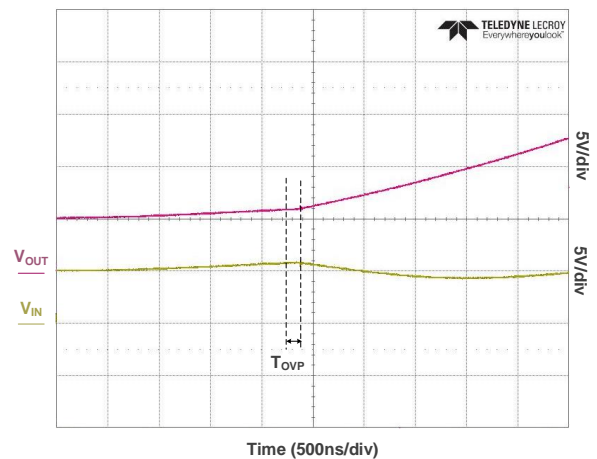
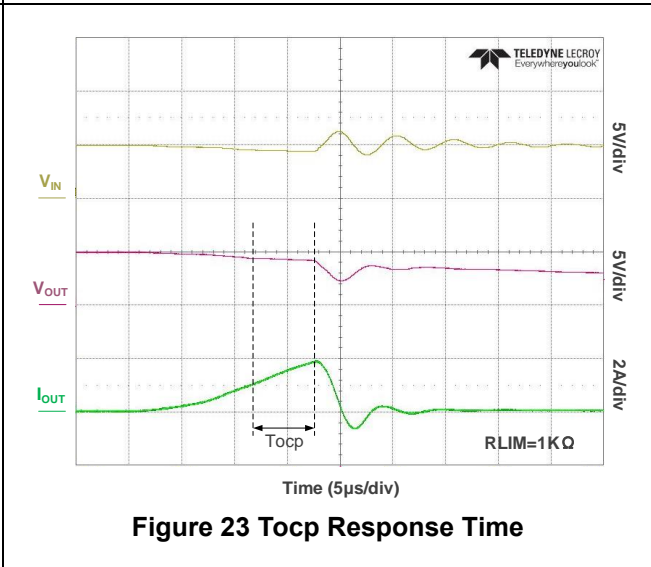
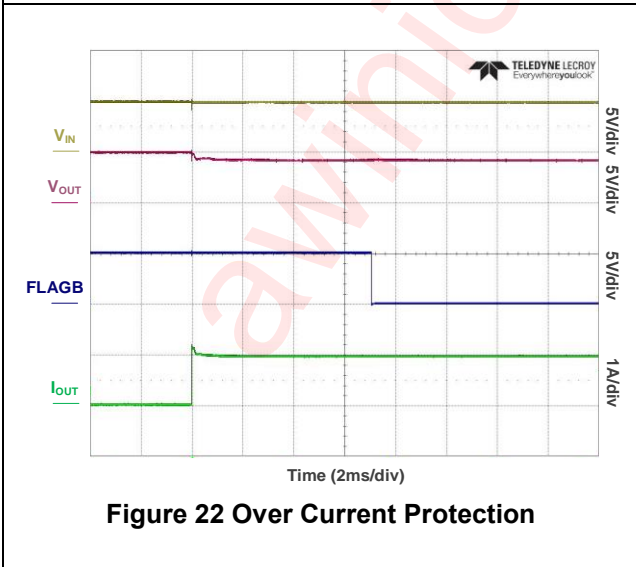
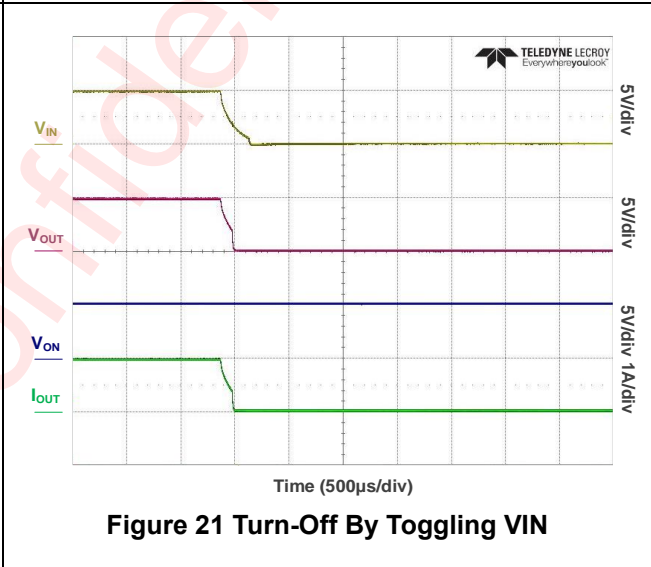
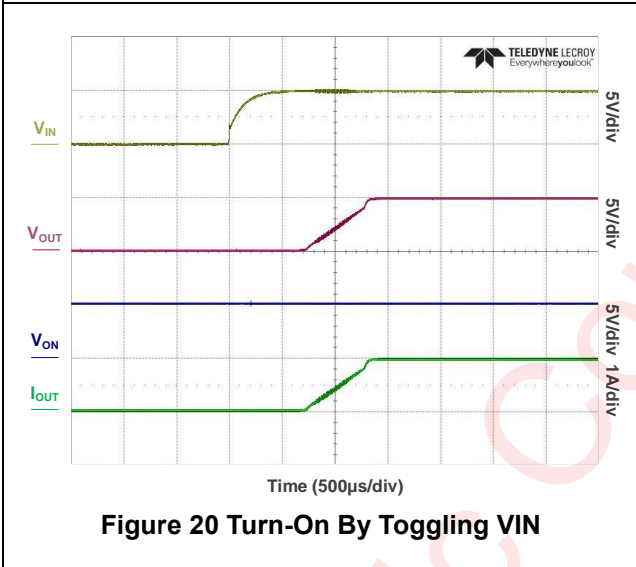
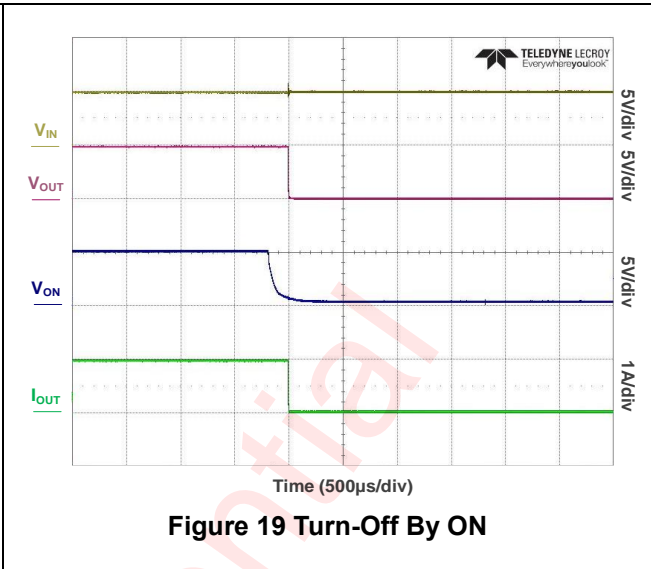
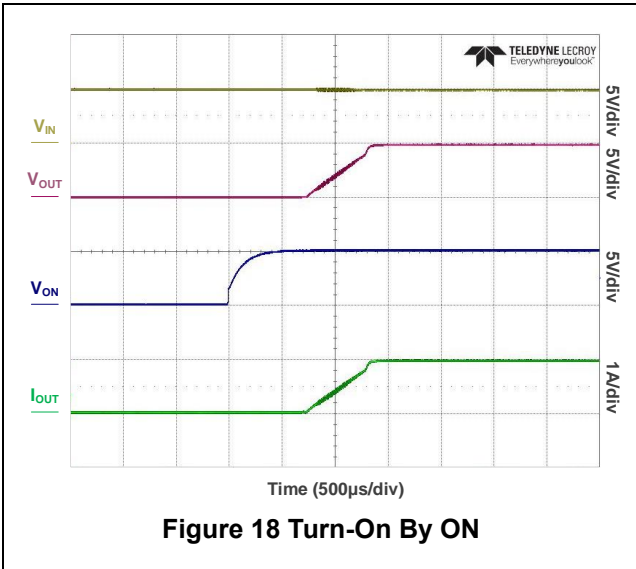

Figure 17 Over Voltage Protection



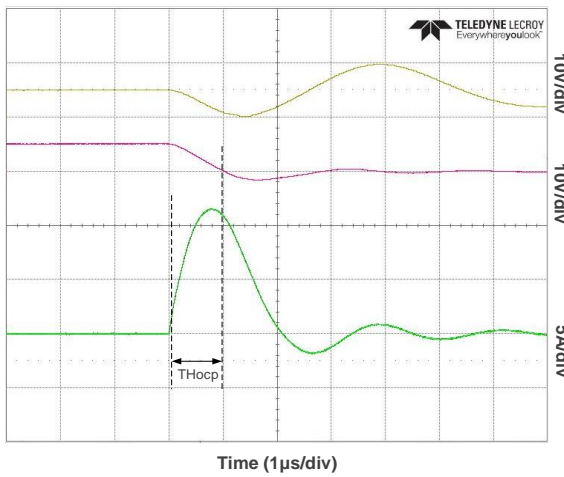

Figure 24 THocp Response Time

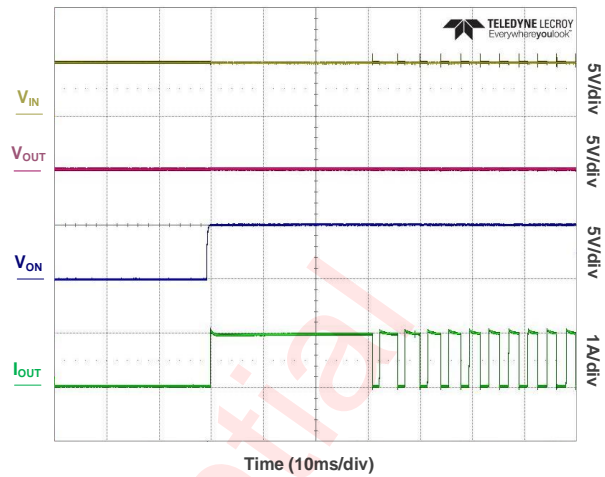

Figure 25 Starting up into shorted output

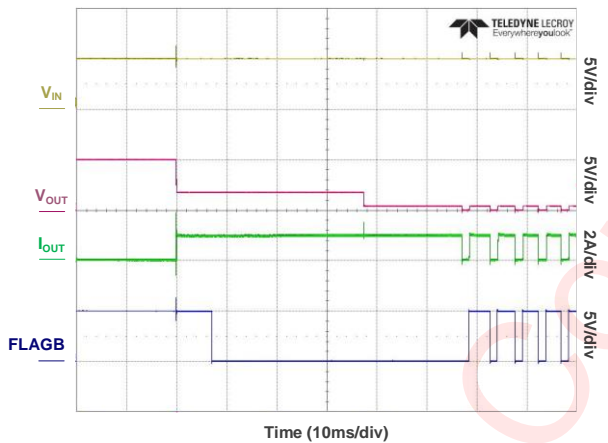

Figure 26 Output Short Circuit Protection

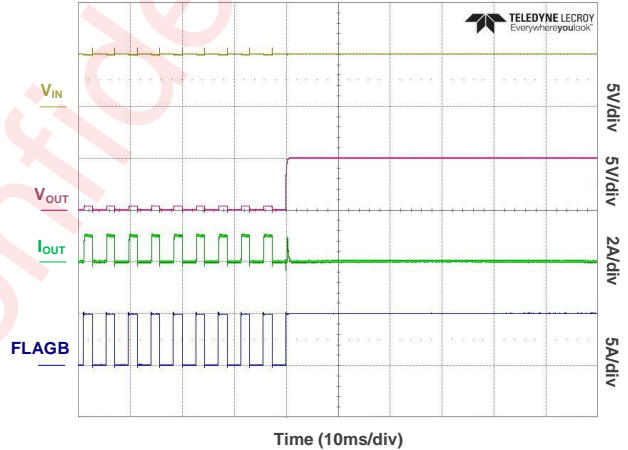

Figure 27 Output Short Circuit Recovery

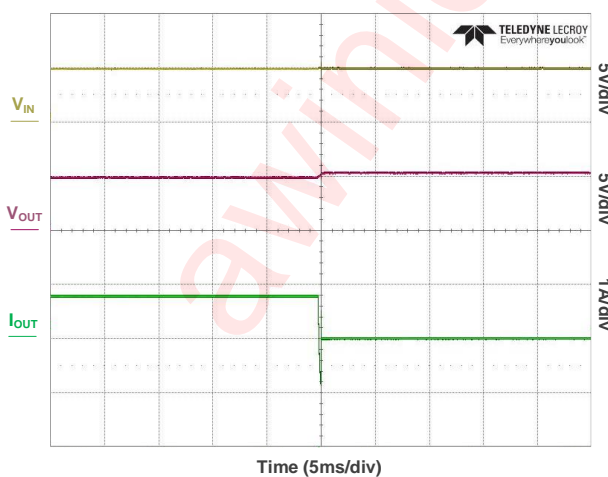

Figure 28 Reverse Current Blocking

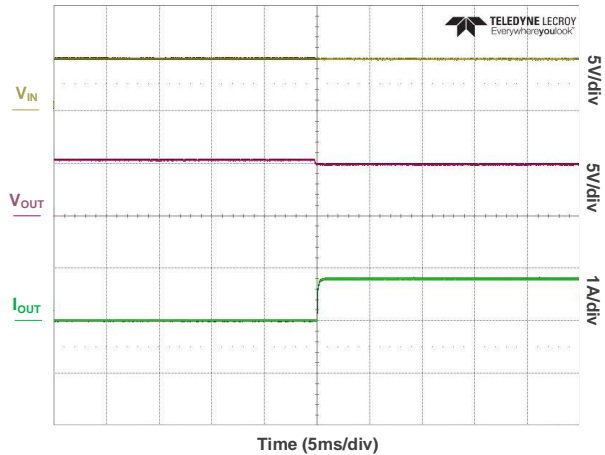

Figure 29 Recovery from Reverse Current Blocking

Detailed Functional Description

The AW35061 is a current limited power switch with over-voltage, over-current, reverse-current and thermal shutdown protections. The VOUT pin is rated 28V. The switch current is rated up to 2.5A.

The device has true reverse-current blocking features that will prevent undesired current flow from output to its input in either enabled or disabled state.

Enable

The ON pin is the ON/OFF control for the power switch. The device is enabled when ON pin is high and not in under-voltage lockout state. The ON pin must be driven to a logic high or logic low state to guarantee operation. While disabled, the AW35061 draws 0.5 μ A from supply.

Soft Start

The AW35061 has internal soft-start circuitry to limit inrush current due to large capacitive load.

Fault Reporting

The FLAGB pin is an open drain output. It is asserted low when either an over-current, or over-temperature condition occurs. The FLAGB pin becomes high impedance when the fault conditions are removed. It is recommended to be pulled up by a 10k Ω pull-up resistor (R_{PU}) connected between FLAGB to 5V to provide a logic signal.

When thermal shutdown is activated, FLAGB is pulled low immediately to report fault condition to host. FLAGB become impedance again once fault is removed. In case of output overload, FLAGB pin is pulled low about 7ms (t_{OC_FLAG}) after device is in current-limiting.

The is no fault reporting for UVLO, OVP, and RCB event.

Under-Voltage Lockout

Under-voltage lockout protection turns off the switch if the input voltage drops below the under-voltage lockout threshold (V_{UVLO}). With the ON pin active, the input voltage rising above V_{UVLO_R} , the switch will return to the ON state.

Over-Voltage Protection

The voltages at V_{OUT} terminal is constantly monitored once the device is enabled. In case output voltage exceeds the over-voltage protection threshold (V_{OVP}), the device is turned off immediately. AW35061 can restart when V_{OUT} drops below V_{OVP_F} .

True Reverse-Current Blocking

True Reverse-Current Blocking (TRCB) protection to avoid undesired reverse current from output to its input in either enabled or disabled states. When device is enabled, device is turned off whenever output voltage is higher than input voltage 50 mV. The device is turned on again when output voltage falls below input by 50mV.

Thermal Shutdown

The thermal shutdown protects the device from internally or externally generated excessive temperature. The power switch is turned off when the die temperature reaches thermal shutdown threshold of 155 $^{\circ}$ C. There is a 20 $^{\circ}$ C hysteresis. The switch automatically turns on again if the temperature of the die drops below approximately 135 $^{\circ}$ C.

Over - Current Protection and Programmable Current Limit

The device continuously monitors the load current and ensure that the current through the switch does not exceed current limit threshold. The current limit value is set with an external resistor connected between the ISET and GND pins. when the switch current reaches the maximum value set by the switch, the switch acts as constant current source until the power dissipation and die temperature to increase and trigger thermal shutdown. The switch recovers if the device temperature drops below the threshold temperature.

During a transient short circuit event, the current through the switch increases very rapidly. The current limit amplifier cannot respond to this event due to its limited bandwidth. Therefore, the AW35061 incorporates a fast-trip comparator, which shuts down the pass switch when $I_{OUT} > I_{FASTTRIP}$, and terminates the rapid short circuit peak current. The fast-trip comparator threshold $I_{FASTTRIP}$ is $1.6I_{SET}$ and shuts down power switch for $7\mu s$. After the transient short-circuit peak current has been terminated by the fast-trip comparator, the current limit amplifier regulates the output current to I_{LIM} .

awinic Confidential

Application Information

Current limit Programming

An external resistor (R_{LIM}) placed between the ISET pin and GND sets the switch current limit threshold (I_{LIM}). The ISET pin voltage is regulated by an internal control loop. The current limit threshold is proportional to the current pulled from the ISET pin by the resistor. Use short trace routes for the R_{LIM} on the PCB to minimize the impact of parasitic and noise on the accuracy of the current limit setting.

The current limit threshold can be estimated using the equation below:

$$I_{LIM} = 2500 \cdot 0.4V / R_{LIM} \text{ (A)}$$

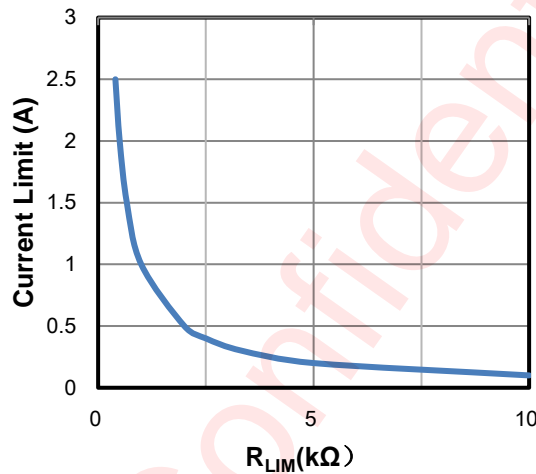

Figure 30 Current Limit Threshold (I_{LIM}) vs. Current Limit Programming Resistor (R_{LIM})

For example, for 1A current limit threshold, a 1k Ω R_{LIM} resistor should be selected.

The current limit resistor setting is shown below in Table 1. The recommended 1% resistor range for R_{LIM} is $400\Omega \leq R_{LIM} \leq 10K\Omega$.

Table 1. Current Limit Settings by R_{LIM}

$R_{LIM}(\Omega)$	MIN. Current Limit(A)	TYP. Current Limit(A)	MAX. Current Limit(A)
400	2.33	2.5	2.67
500	1.86	2	2.14
666	1.395	1.5	1.6
1000	0.93	1	1.07
2000	0.465	0.5	0.535
2500	0.36	0.4	0.44
3333	0.255	0.3	0.345
5000	0.17	0.2	0.23
10000	0.085	0.1	0.115

Power Dissipation Calculation

Calculate the power dissipation for normal load condition using the following equation:

$$\text{Power Dissipated} = R_{\text{ON}} \times (I_{\text{OUT}})^2$$

The worst cases power dissipation occurs when the load current hits the current limit due to over-current. The power dissipation can be calculated using the following equation:

$$\text{Power Dissipated} = (V_{\text{IN}} - V_{\text{OUT}}) \times I_{\text{LIM}}$$

Assuming a given ambient temperature and an output current, the maximum allowable power dissipation is calculated by:

$$P_{\text{D(MAX)}} = T_{\text{J(MAX)}} - T_{\text{A}} / \theta_{\text{JA}}$$

where:

$P_{\text{D(MAX)}}$ is the maximum power dissipation.

$T_{\text{J(MAX)}}$ is the maximum operating junction temperature.

T_{A} is the operating ambient temperature.

θ_{JA} is junction to air thermal impedance.

Please note that the thermal vias are placed under the exposed pad of the device, thus allowing for thermal dissipation away from the device.

Input Capacitor Selection

The input capacitor prevents large voltage transients from appearing at the input, and provides the instantaneous current needed each time the switch turns on to charge output capacitors and to limit input voltage drop. It also prevents high-frequency noise on the power line from passing through to the output. The input capacitor should be located as close to the pin as possible. A minimum of 1 μ F ceramic capacitor should be used. However, higher capacitor value is strongly recommended to further reduce the transient voltage drop at the input. It is recommended to use a 1 μ F capacitor between VIN and GND close to the device pins. It can limit the voltage drop of the input supply. Larger C_{IN} can reduce voltage dip in high current applications. Without or smaller an input capacitor, short-circuit and surge at the output will cause the input voltage to ring, which may destroy the chip's internal circuitry when the input transient voltage exceeds the absolute maximum supply voltage (6V).

Output Capacitor Selection

To reduce EMI, improve the transient performance, and minimize negative effects of resistance and inductance between the bypass capacitor and the downstream connector, a low-ESR 1 μ F ceramic capacitor between VOUT and GND standard bypass methods are recommended. The output capacitor has to supply enough current for a large load that it may encounter during system transient. This bulk capacitor must be large enough to supply fast transient load in order to prevent the output from dropping. There is an upper limit for output capacitor for AW35061 to ensure the output capacitor can be charged fully during start-up.

PCB Layout Guidelines

Reasonable PCB layout is important for improving the thermal and overall performance of AW35061. For best results, follow the guidelines below:

- 1、 It is recommended to bypass VIN to GND with a 1 μ F or greater ceramic capacitor as close as possible to the VIN pin;

- 2、 It is recommended to bypass VOUT to GND with a 1 μ F or greater ceramic capacitor as close as possible to the VOUT pin. The internal soft-start function allows the AW35061 to charge an output capacitor up to 100 μ F without turning off due to overcurrent;
- 3、 To optimize the switch response time to output short-circuit conditions, the traces routing the R_{LIM} to the AW35061 must be as short as possible to reduce the effect of unwanted parasitic capacitor;
- 4、 The input and output PCB traces as short and wide as possible to reduce the unwanted effect of long wire; For 1 ounces of copper and use at least 3mm wire width; For 2 ounces of copper and use at least 2mm wire width;
- 5、 Placing a ground plane under all circuits to reduce resistance and inductance will improve DC and transient performances.

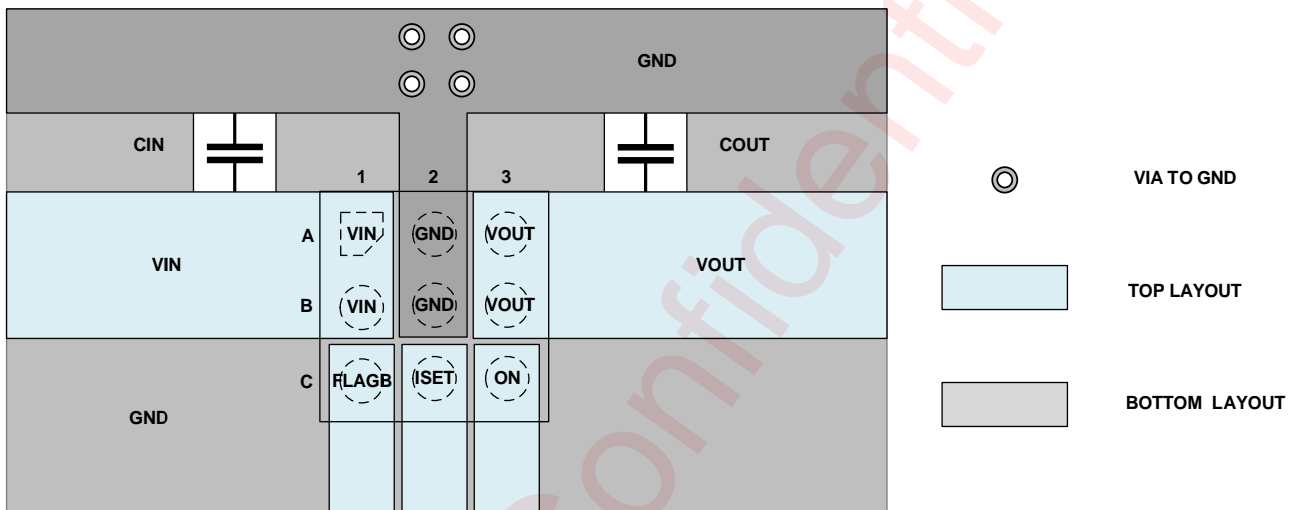
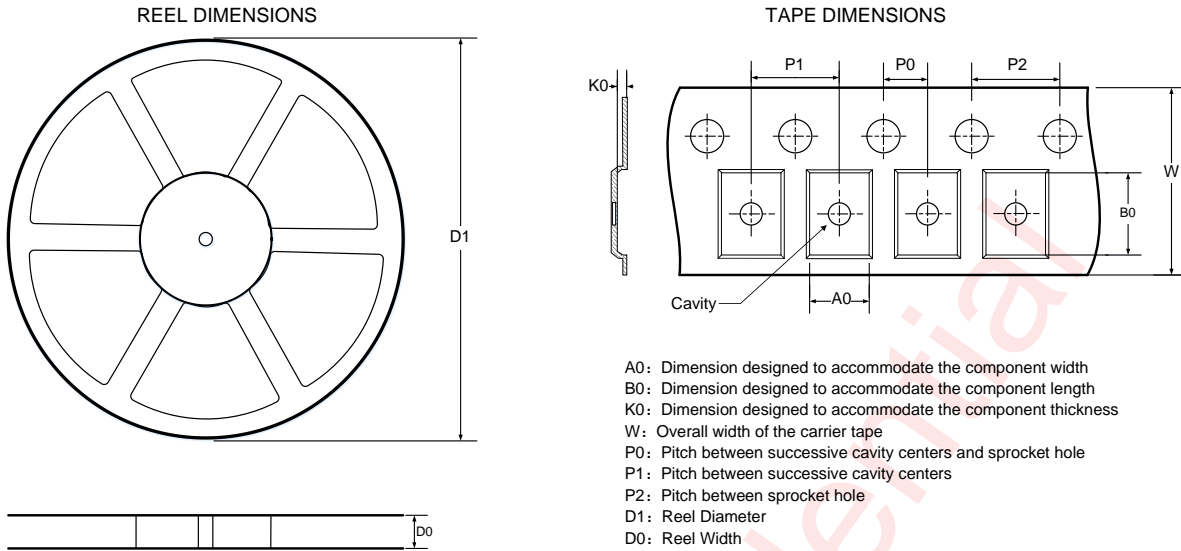
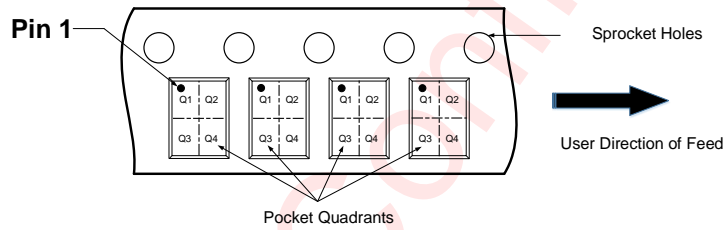

Figure 31 AW35061 PCB Layout Example

Tape And Reel Information



QUADRANT ASSIGNMENTS FOR PIN 1 ORIENTATION IN TAPE



Note: The above picture is for reference only. Please refer to the value in the table below for the actual size

DIMENSIONS AND PIN1 ORIENTATION

D1 (mm)	D0 (mm)	A0 (mm)	B0 (mm)	K0 (mm)	P0 (mm)	P1 (mm)	P2 (mm)	W (mm)	Pin1 Quadrant
180	8.4	1.38	1.38	0.75	2	4	4	8	Q1

All dimensions are nominal

Package Description

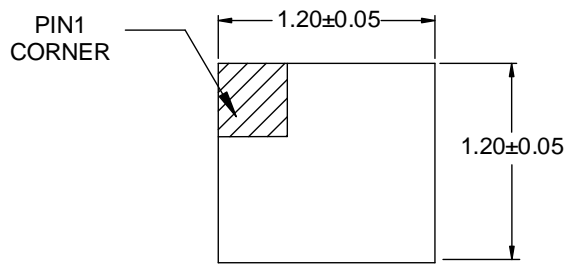

Top View

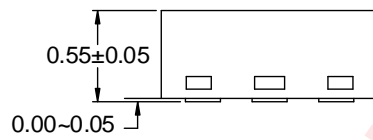

Side View

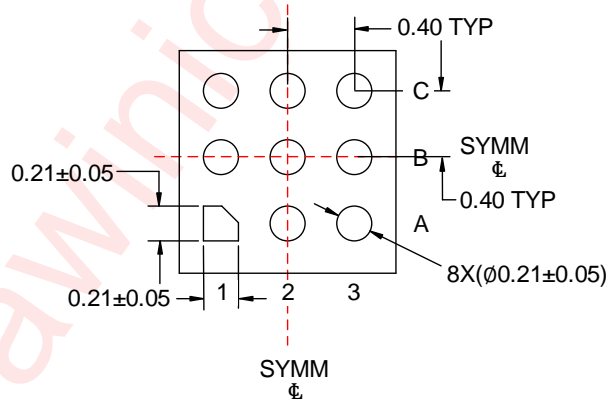

Bottom View

Unit:mm

Land Pattern Data

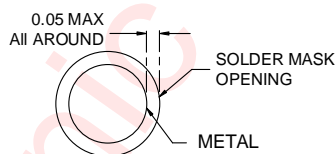
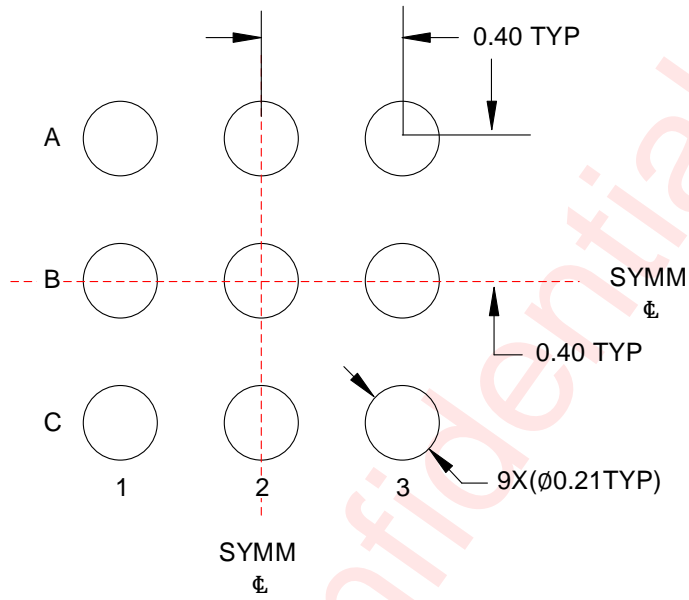

NON SOLDER MASK DEFINED

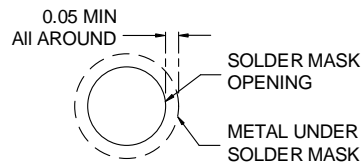

SOLDER MASK DEFINED

Unit: mm

Revision History

Version	Date	Change Record
V1.0	Mar. 2023	The preliminary datasheet V1.0 released.
V1.1	Oct. 2023	Update $I_{Q(OFF)}$ and $I_{SD(OFF)}$ max. Value.

awinic Confidential

Disclaimer

All trademarks are the property of their respective owners. Information in this document is believed to be accurate and reliable. However, Shanghai AWINIC Technology Co., Ltd (AWINIC Technology) does not give any representations or warranties, expressed or implied, as to the accuracy or completeness of such information and shall have no liability for the consequences of use of such information.

AWINIC Technology reserves the right to make changes to information published in this document, including without limitation specifications and product descriptions, at any time and without notice. Customers shall obtain the latest relevant information before placing orders and shall verify that such information is current and complete. This document supersedes and replaces all information supplied prior to the publication hereof.

AWINIC Technology products are not designed, authorized or warranted to be suitable for use in medical, military, aircraft, space or life support equipment, nor in applications where failure or malfunction of an AWINIC Technology product can reasonably be expected to result in personal injury, death or severe property or environmental damage. AWINIC Technology accepts no liability for inclusion and/or use of AWINIC Technology products in such equipment or applications and therefore such inclusion and/or use is at the customer's own risk.

Applications that are described herein for any of these products are for illustrative purposes only. AWINIC Technology makes no representation or warranty that such applications will be suitable for the specified use without further testing or modification.

All products are sold subject to the general terms and conditions of commercial sale supplied at the time of order acknowledgement.

Nothing in this document may be interpreted or construed as an offer to sell products that is open for acceptance or the grant, conveyance or implication of any license under any copyrights, patents or other industrial or intellectual property rights.

Reproduction of AWINIC information in AWINIC data books or data sheets is permissible only if reproduction is without alteration and is accompanied by all associated warranties, conditions, limitations, and notices. AWINIC is not responsible or liable for such altered documentation. Information of third parties may be subject to additional restrictions.

Resale of AWINIC components or services with statements different from or beyond the parameters stated by AWINIC for that component or service voids all express and any implied warranties for the associated AWINIC component or service and is an unfair and deceptive business practice. AWINIC is not responsible or liable for any such statements.