

Multi-Rate SDI Reclocker with Equalization & De-emphasis

Features

- SMPTE ST 424, SMPTE ST 292 and SMPTE ST 259-C compliant
- Supports DVB-ASI at 270Mb/s
- Single supply operation at 3.3V or 2.5V
- 180mW typical power consumption (213mW with RCO enabled) at 2.5V
- Input signal equalization and output-signal de-emphasis settings to compensate for board-trace dielectric losses
- 2:1 input multiplexer patented technology
- Choice of dual reclocked data outputs or one reclocked data output and one clock output
- Uses standard 27MHz crystal
- Differential inputs and outputs
 - ◆ support DC coupling to industry-standard differential logic
 - ◆ on-chip 100Ω differential data input/output termination
 - ◆ selectable 400mVppd or 800mVppd output swing on each output
 - ◆ seamless interface to other Gennum products
- 4 wire SPI host interface for device configuration and monitoring
- Standard logic control and status signal levels
- Auto and Manual modes for rate selection
- Standards indication in Auto mode
- Lock Detect Output
- Mute, Bypass and Autobypass functions
- SD/HD indication output to control GS2978 or GS2988 dual slew-rate cable drivers
- Operating temperature range: -40°C to +85°C
- 32 pin 5mm x 5mm QFN package
- Pb-free and RoHS compliant

Applications

- SMPTE ST 424, SMPTE ST 292 and SMPTE ST 259-C coaxial cable serial digital interfaces

Description

The GS2965 is a multi-rate serial digital reclocker designed to automatically recover the embedded clock from a digital video signal and retime the incoming video data. It will recover the embedded clock signal and retime the data from a SMPTE ST 424, SMPTE ST 292, or SMPTE ST 259-C compliant digital video signal.

A serial host interface provides the ability to configure and monitor multiple GS2965 devices in a daisy-chain configuration.

Adjustable input trace equalization (EQ) for up to 40" of FR4 trace losses, and adjustable output de-emphasis (DE) for up to 20" of FR4 trace losses, can be configured via the host interface.

The GS2965 can operate in either auto or manual rate selection mode. In Auto mode, the device will automatically detect and lock onto incoming SMPTE SDI data signals at any supported rate. For single rate data systems, the GS2965 can be configured to operate in Manual mode. In both modes, the device requires only one external crystal to set the VCO frequency when not locked and provides adjustment free operation.

The GS2965 accepts industry-standard differential input levels including LVPECL and CML. The differential data and clock outputs feature selectable output swing via the host interface, ensuring compatibility with most industry-standard, terminated differential receivers.

The GS2965 features dual differential outputs. The second output can be configured to emit either the recovered clock signal or the re-timed video data. This output can also be disabled to save power.

In systems which require passing of non-SMPTE data rates, the GS2965 can be configured to either automatically or manually enter a bypass mode in order to pass the signal without reclocking.

The GS2965 is Pb-free, and the encapsulation compound does not contain halogenated flame retardant. This component and all homogeneous sub-components are RoHS compliant.

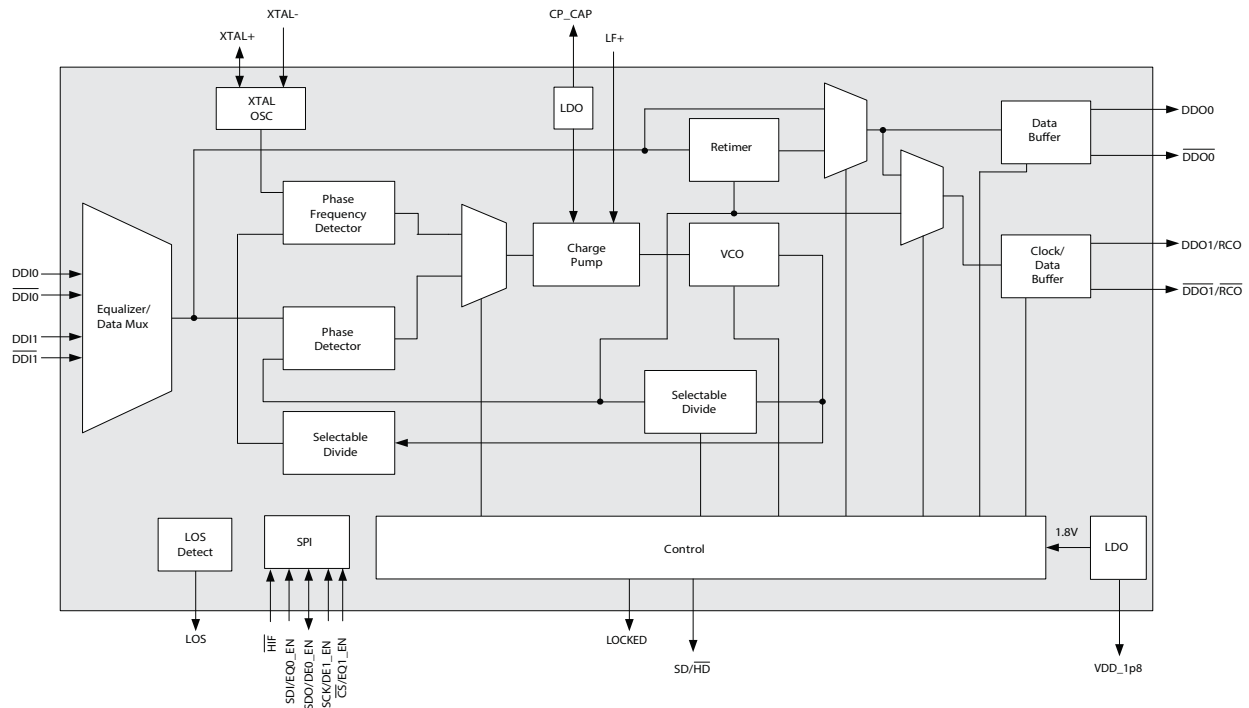

GS2965 Functional Block Diagram

Revision History

Version	ECO	PCN	Date	Changes and/or Modifications
7	027463	-	August 2015	Updated Table 4-5: Suggested LOS Threshold Settings to units of mV _{ppd} .
6	026631	-	July 2015	Removed any references to TSLP package size data in the document. Updated to latest Semtech template.
5	016900	-	December 2013	Corrected lock time parameter in Section 4.16 . Updates to document format.
4	158268	-	July 2012	Removed jumper from Figure 5-1: GS2965 Typical Application Circuit .
3	158128	-	May 2012	Corrected 4.15.3 section to make it easier to follow and changed to Semtech Template.
2	157651	-	February 2012	Correction to Pin Number 9 under Description column in Table 1-1: GS2965 Pin Descriptions . Updated Section 4.14 .
1	153705	-	March 2010	Converted to Data Sheet. Updated Power numbers in Table 2-2: DC Electrical Characteristics . Added Table 4-5: Suggested LOS Threshold Settings .
0	152589	-	September 2009	Converted to Preliminary Data Sheet. Updates to Electrical Characteristics . Updates to Section 4.15 Host Interface .
C	151996	-	July 2009	Added Section 4.15 Host Interface . Updated Power numbers in Table 2-2: DC Electrical Characteristics and Loop Bandwidth numbers in Table 2-3: AC Electrical Characteristics . Added Table 1-2: GS2965 Default Start-up Settings and Figure 4-2: De-emphasis Waveform .

Version	ECO	PCN	Date	Changes and/or Modifications
B	151955	-	May 2009	Changed 6.1 Package Dimensions, 6.2 Recommended PCB Footprint.
A	151772	-	April 2009	New document.

Contents

1. Pin Out	5
1.1 Pin Assignment	5
1.2 Pin Descriptions	5
1.3 Default Start-up Settings	8
2. Electrical Characteristics.....	9
2.1 Absolute Maximum Ratings	9
2.2 DC Electrical Characteristics	9
2.3 AC Electrical Characteristics	11
3. Input/Output Circuits.....	13
4. Detailed Description.....	16
4.1 Serial Data Input	16
4.2 Modes of Operation	16
4.3 Input Trace Equalization	16
4.4 2:1 Input Mux	17
4.5 Crystal Buffer	18
4.6 LOS (Loss Of Signal) Detection	18
4.7 Serial Digital Reclocker	19
4.8 Lock Detection	19
4.8.1 Lock Detect and Asynchronous Lock.....	20
4.9 Serial Data Output	20
4.9.1 Output Signal Interface Levels	20
4.9.2 Adjustable Output Swing.....	20
4.9.3 Output De-emphasis.....	21
4.10 Automatic and Manual Data Rate Selection	22
4.11 SD/ \overline{HD} Indication	22
4.12 Bypass Mode	23
4.13 DVB-ASI	23
4.14 Output Mute and Data/Clock Output Selection	23
4.15 Host Interface	24
4.15.1 Introduction.....	24
4.15.2 Legacy Mode & Start-up.....	24
4.15.3 Host Interface Mode & Start-up.....	25
4.15.4 Clock & Data Timing.....	25
4.15.5 Single Device Operation.....	25
4.15.6 Write Operation - Single Device.....	26

4.15.7 Read Operation - Single Device	27
4.15.8 Daisy Chain Operation	29
4.15.9 Read & Write Operation - Daisy Chained Devices	30
4.15.10 Writing to all Devices	30
4.15.11 Writing to a Single Device in the Chain.....	31
4.15.12 Reading from all Devices	31
4.15.13 Reading from a Single Device in the Chain.....	32
4.15.14 Host Register Map	33
4.16 Device Power Up	36
4.17 Standby	36
5. Typical Application Circuit	37
6. Package and Ordering Information	38
6.1 Package Dimensions	38
6.2 Recommended PCB Footprint	38
6.3 Packaging Data	39
6.4 Marking Diagram	39
6.5 Solder Reflow Profile	40
6.6 Ordering Information	40

1. Pin Out

1.1 Pin Assignment

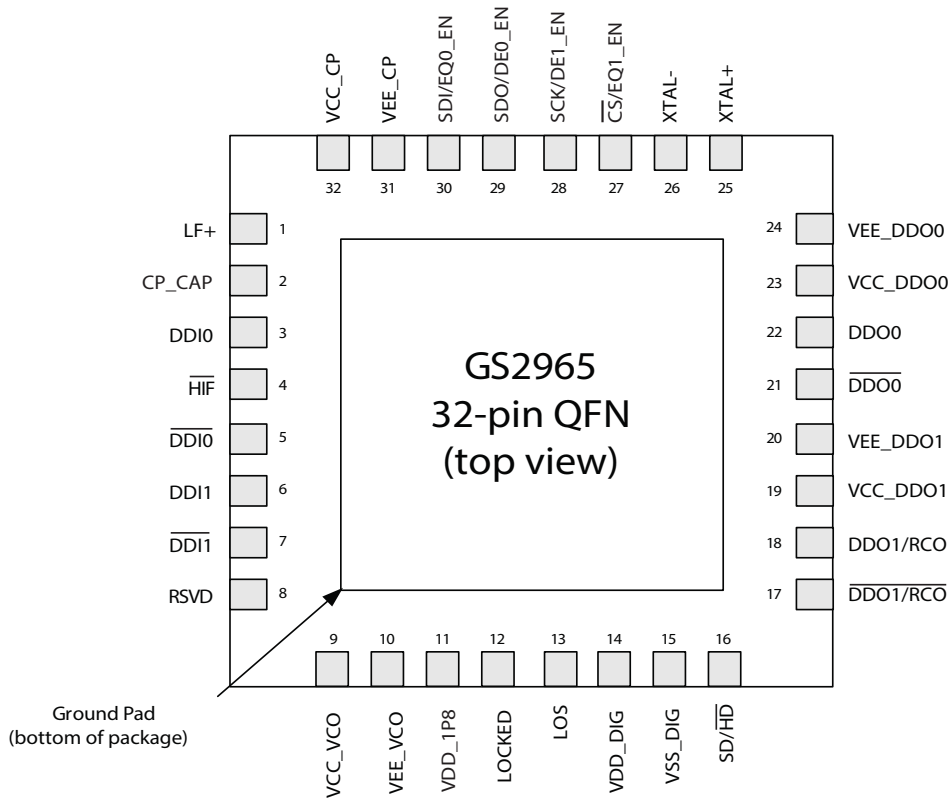

Figure 1-1: GS2965 Pin Out

1.2 Pin Descriptions

Table 1-1: GS2965 Pin Descriptions

Pin Number	Name	Type	Description
1	LF+	Passive	Loop Filter capacitor connection. (CLF = 47nF). Connect as shown in Typical Application Circuit on page 37 .
2	CP_CAP	Power	External capacitor for internal LDO regulator supplying the charge pump circuit.
3, 5	DDI0, $\overline{\text{DDI0}}$	Input	Serial Digital Differential Input 0.
4	$\overline{\text{HIF}}$	Logic Input	Host interface selection pin. Active-low input. See Section 4.15.1 .
6, 7	DDI1, $\overline{\text{DDI1}}$	Input	Serial Digital Differential Input 1.
8	RSVD	Reserved	Reserved pin. Do not connect to this pin.

Table 1-1: GS2965 Pin Descriptions (Continued)

Pin Number	Name	Type	Description
9	VCC_VCO	Power	Most positive power supply connection for the internal VCO section. Connect to a 3.3V supply with a 422Ω resistor, or a 2.5V supply with a 267Ω resistor.
10	VEE_VCO	Power	Most negative power supply connection for the internal VCO section. Connect to GND.
11	VDD_1P8	Power	External capacitor for internal 1.8V digital supply.
12	LOCKED	Output	Lock Detect status signal. HIGH when the PLL is locked.
13	LOS	Output	Loss Of Signal status. HIGH when the input signal is invalid.
14	VDD_DIG	Power	Most positive power supply connection for the digital core. Connect to 3.3V or 2.5V.
15	VSS_DIG	Power	Most negative power supply for the digital core. Connect to GND.
16	SD/ $\overline{\text{HD}}$	Output	This signal will be LOW for all rates other than 270Mb/s. This signal is HIGH for 270Mb/s.
17, 18	$\overline{\text{DDO1/RCO}}$, DDO1/RCO	Output	Differential serial clock or data outputs.
19	VCC_DDO1	Power	Most positive power supply connection for the DDO1/ $\overline{\text{DDO1}}$ output driver. Connect to 3.3V or 2.5V.
20	VEE_DDO1	Power	Most negative power supply connection for the DDO1/ $\overline{\text{DDO1}}$ output driver. Connect to GND.
21, 22	$\overline{\text{DDO0}}$, DDO0	Output	Differential Serial Digital Outputs.
23	VCC_DDO0	Power	Most positive power supply connection for the DDO0/ $\overline{\text{DDO0}}$ output driver. Connect to 3.3V or 2.5V.
24	VEE_DDO0	Power	Most negative power supply connection for the DDO0/ $\overline{\text{DDO0}}$ output driver. Connect to GND.
25	XTAL+	Output	Reference crystal output.
26	XTAL-	Input	Reference crystal input.
27	$\overline{\text{CS}}$ /EQ1_EN	Input/Logic Input	In host mode ($\overline{\text{HIF}}$ set LOW): Chip select input for SPI serial host interface. Active-low input. In non-host mode ($\overline{\text{HIF}}$ set HIGH): Trace equalization on/off pin for Serial Digital Differential Input 1. Active-high input.
28	SCK/DE1_EN	Input/Logic Input	In host mode ($\overline{\text{HIF}}$ set LOW): Burst-mode clock input for SPI serial host interface. In non-host mode ($\overline{\text{HIF}}$ set HIGH): De-emphasis on/off pin for Serial Digital Differential Output 1. Active-high input.

Table 1-1: GS2965 Pin Descriptions (Continued)

Pin Number	Name	Type	Description
29	SDO/DE0_EN	Input/Logic Input	In host mode ($\overline{\text{HIF}}$ set LOW): Serial digital data output for SPI serial host interface. Active-high output. In non-host mode ($\overline{\text{HIF}}$ set HIGH): De-emphasis on/off pin for Serial Digital Differential Output 0. Active-high input.
30	SDI/EQ0_EN	Input/Logic Input	In host mode ($\overline{\text{HIF}}$ set LOW): Serial digital data input for SPI serial host interface. Active-high input. In non-host mode ($\overline{\text{HIF}}$ set HIGH): Trace equalization on/off pin for Serial Digital Differential Input 0. Active-high input.
31	VEE_CP	Power	Most negative power supply connection for the internal charge pump. Connect to GND.
32	VCC_CP	Power	Most positive power supply connection for the internal charge pump. Connect to 3.3V or 2.5V
–	Center Pad	–	Ground pad on bottom of package. Connect to GND.

1.3 Default Start-up Settings

The GS2965 has some functions that are not accessible via direct pin control, and are only accessible through the host interface registers. These functions have an internal pull-up or pull-down resistor that sets the default logic level or start-up state, if it is not already set by a pin.

If the user wishes to override these logic levels, the associated bit should be programmed within the PIN_OR_1 register (pin override register) at address 0x0C. The logic values within the PIN_OR_1 register become active when the user sets the Pin Override Enable bit to HIGH within that same register.

Table 1-2 shows:

1. The default logic state set by the internal pull up or pull down resistors.
2. The default values within the Pin Override register upon reset.

More details are given in [Section 4.15](#).

Table 1-2: GS2965 Default Start-up Settings

Name	Description	Default State set by Internal Resistors	Default State within the Pin Override Register
DDI_SEL[0:1]	Selects one of two serial digital input signals for processing. DDI0 is selected by default.	0:0	0:0
BYPASS	Bypasses the reclocker stage when set HIGH.	0	0
AUTOBYPASS	When set HIGH, this bit automatically bypasses the reclocker stage when the PLL is not locked to a supported rate.	0	0
AUTO/ $\overline{\text{MAN}}$	When set HIGH, the standard is automatically detected from the input data rate.	1	0
SS0, SS1	When AUTO/ $\overline{\text{MAN}}$ is set HIGH, SS[1:0] are outputs displaying the data rate to which the PLL has locked. Therefore, they will not have default values.	None	0:0
KBB	Controls the loop bandwidth of the PLL.	Floating	Ground
$\overline{\text{DATA_MUTE}}$	Mutes the DDO0/ $\overline{\text{DDO0}}$ and DDO1/ $\overline{\text{DDO1}}$ (if data is selected) outputs when LOW.	1	0
$\overline{\text{DDO1_DISABLE}}$	Disables the DDO1/RCO and $\overline{\text{DDO1/RCO}}$ outputs when LOW.	0	0
DATA/ $\overline{\text{CLOCK}}$	HIGH = DATA LOW = CLOCK	0	0

2. Electrical Characteristics

2.1 Absolute Maximum Ratings

Table 2-1: Absolute Maximum Ratings

Parameter	Value
Supply Voltage	-0.5 to +3.6V _{DC}
Input ESD Voltage	4kV
Storage Temperature Range	-50°C < T _A < 125°C
Operating Temperature Range	-40°C to 85°C
Input Voltage Range	-0.3 to (VCC + 0.3) V _{DC}
Solder Reflow Temperature	260°C

2.2 DC Electrical Characteristics

Table 2-2: DC Electrical Characteristics

Parameter	Symbol	Conditions	Min	Typ	Max	Units
Supply Voltage	VDD	3.3V	3.135	3.3	3.465	V
		2.5V	2.375	2.5	2.625	V
Power (DDO1/RCO disabled, minimum output swing)		VDD = 3.3V	–	250	325	mW
		VDD = 2.5V	–	180	235	mW
Power (DDO1/RCO enabled, minimum output swing)	P	VDD = 3.3V	–	290	390	mW
		VDD = 2.5V	–	210	275	mW
Power in Power-down mode		VDD = 3.3V	–	48	60	mW
		VDD = 2.5V	–	30	40	mW
Serial Input Termination	–	Differential	80	100	120	Ω
Serial Output Termination	–	Differential	80	100	120	Ω
Serial Input Common Mode Voltage	–	–	1.6	–	VDD	V
Serial Output Common Mode Voltage	–	–	–	VCC- (ΔVOD /2)	–	V
VIL (2.5V operation)	–	VOUT ≤ VOL, max	-0.3	–	0.7	V
VIL (3.3V operation)	–	VOUT ≤ VOL, max	-0.3	–	0.8	V

Table 2-2: DC Electrical Characteristics (Continued)

Parameter	Symbol	Conditions	Min	Typ	Max	Units
VIH (2.5V operation)		VOUT \geq VOH, min	1.7	–	VDD +0.3	V
VIH (3.3V operation)		VOUT \geq VOH, min	2	–	VDD +0.3	V
IIN	–	VIN = 0V or VIN = VDD	–	+/-10	+/-20	μ A
VOL (2.5V operation)		VDD = min, IOL = 100 μ A	–	–	0.4	V
VOL (3.3V operation)		VDD = min, IOL = 100 μ A	–	–	0.4	V
VOH (2.5V operation)		VDD = min, IOH = -100 μ A	2.1	–	–	V
VOH (3.3V operation)		VDD = min, IOH = -100 μ A	VDD -0.4	–	–	V
Hysteresis Voltage (SPI inputs)		2.5V operation	–	350	–	mV
NOTE: guaranteed by simulation.		3.3V operation	–	350	–	mV

2.3 AC Electrical Characteristics

Table 2-3: AC Electrical Characteristics

Parameter	Symbol	Conditions	Min	Typ	Max	Units	Notes
Serial Input Data Rate (for reclocking)	DR _{SDO}	–	0.27	–	2.97	Gb/s	–
Serial Input Data Rate (bypass)		–	DC	–	2.97	Gb/s	–
SPI Operating Speed	–	–	–	–	10	MHz	–
Input Voltage Swing	ΔVSDI	Set ATTEN_EN = 1 for ΔVSDI > 1V _{pp}	100	–	2000	mV _{p-pd}	–
Output Voltage Swing	ΔVOD	default	300	400	500	mV _{p-pd}	–
		see DRIVER_1 register (0x01) addresses 8 & 9 in 4.15.14 Host Register Map .	600	800	1000	mV _{p-pd}	–
Input Trace Equalization	–	LOW	Recommended setting for 0 to 10 inches of FR4			–	
		MED	Recommended setting for 10 to 20 inches of FR4			–	
		HIGH	Recommended setting for >20 inches of FR4			–	
Output De-Emphasis	–	OFF - 0	–	0	–	dB	–
		ON - 0	–	0	–	dB	–
		ON - 1	–	0.7	–	dB	–
		ON - 2	–	1.3	–	dB	–
		ON - 3	–	2	–	dB	–
		ON - 4	–	2.6	–	dB	–
		ON - 5	–	3.3	–	dB	–
		ON - 6	–	4	–	dB	–
ON - 7	–	4.7	–	dB	–		
Input Jitter Tolerance	–	square-wave modulated jitter	0.8	–	–	UI	–

Table 2-3: AC Electrical Characteristics (Continued)

Parameter	Symbol	Conditions	Min	Typ	Max	Units	Notes
Loop Bandwidth	BW_{LOOP} (270Mb/s)	KBB = VCC	–	170	–	kHz	–
		KBB = FLOAT	–	340	–	kHz	–
		KBB = GND	–	680	–	kHz	–
	BW_{LOOP} (1485Mb/s)	KBB = VCC	–	0.875	–	MHz	–
		KBB = FLOAT	–	1.75	–	MHz	–
		KBB = GND	–	3.5	–	MHz	–
	BW_{LOOP} (2970Mb/s)	KBB = VCC	–	1.75	–	MHz	–
		KBB = FLOAT	–	3.5	–	MHz	–
		KBB = GND	–	7.0	–	MHz	–
PLL Lock Time (asynchronous)	t_{alock}	–	0.5	1	ms	–	
PLL Lock Time (synchronous)	t_{slock}	CLF = 47nF, SD/H $\overline{\text{D}}$ = 0	–	0.5	4	μs	–
		CLF = 47nF, SD/H $\overline{\text{D}}$ = 1	–	5	10	μs	–
Serial Data Output Jitter Intrinsic (DDO0)	$t_{\text{OJ}(270\text{MB/s})}$	KBB = FLOAT PRN 2 ²³ -1 test pattern	–	0.01	–	UI	–
	$t_{\text{OJ}(1485\text{MB/s})}$	KBB = FLOAT PRN 2 ²³ -1 test pattern	–	0.03	–	UI	–
	$t_{\text{OJ}(2970\text{MB/s})}$	KBB = FLOAT PRN 2 ²³ -1 test pattern	–	0.05	–	UI	–
Output Rise/Fall Time	tr/f	20% to 80% (400mV swing)	–	65	–	ps	–
		20% to 80% (800mV swing)	–	80	–	ps	–
Output Rise/Fall Time Mismatch	–	–	–	–	15	ps	–
Eye Cross Shift	–	percentage of signal amplitude	–	–	5	%	–
Power Supply Noise Rejection	–	50 - 100Hz	–	100	–	mV _{p-p}	–
		100Hz - 10MHz	–	40	–	mV _{p-p}	–
		10MHz - 1.485GHz	–	10	–	mV _{p-p}	–

3. Input/Output Circuits

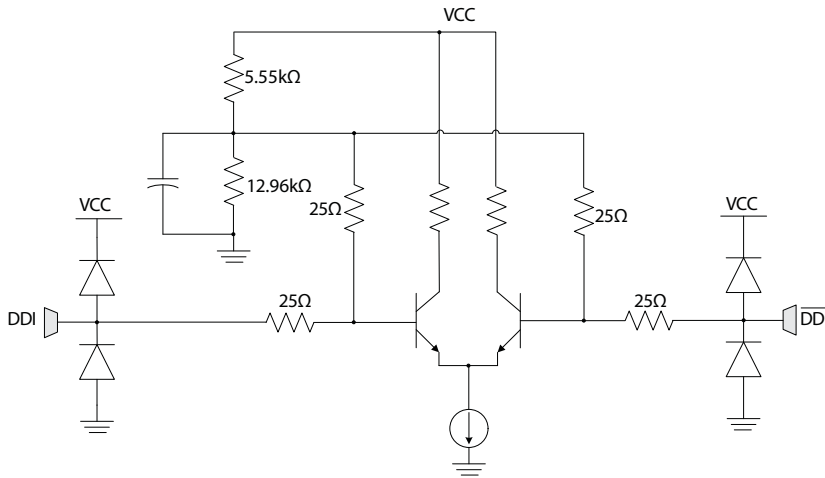

Figure 3-1: High-speed Inputs (DDI0, $\overline{\text{DDI0}}$, DDI1, $\overline{\text{DDI1}}$)

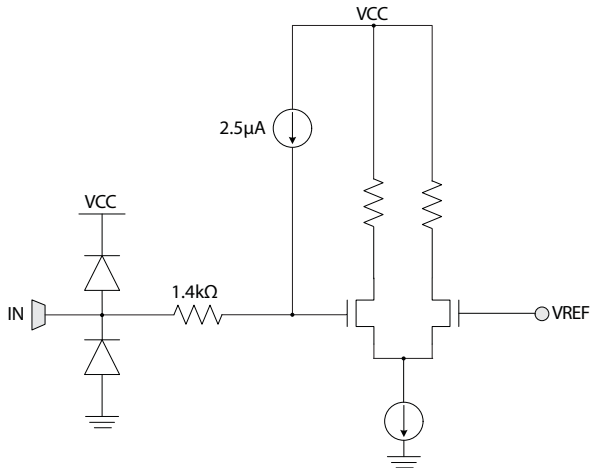

Figure 3-2: Low-speed Input with weak internal pull-up ($\overline{\text{HIF}}$)

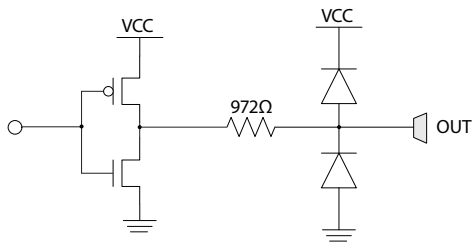

Figure 3-3: Low-speed Outputs (LOCKED, LOS, $\overline{\text{SD/H\overline{D}}}$)

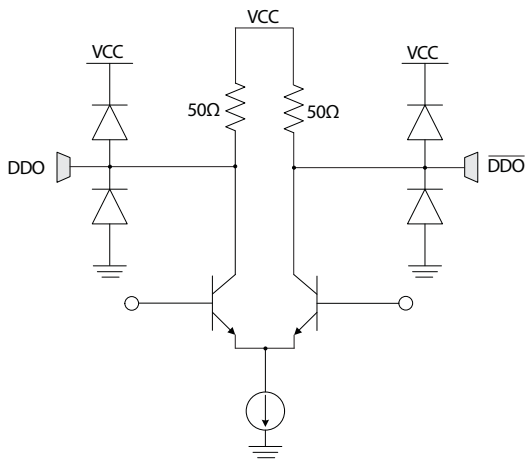

Figure 3-4: High-speed Outputs ($\overline{DDO1}/\overline{RCO}$, $DDO1/RCO$, $\overline{DDO0}$, $DDO0$)

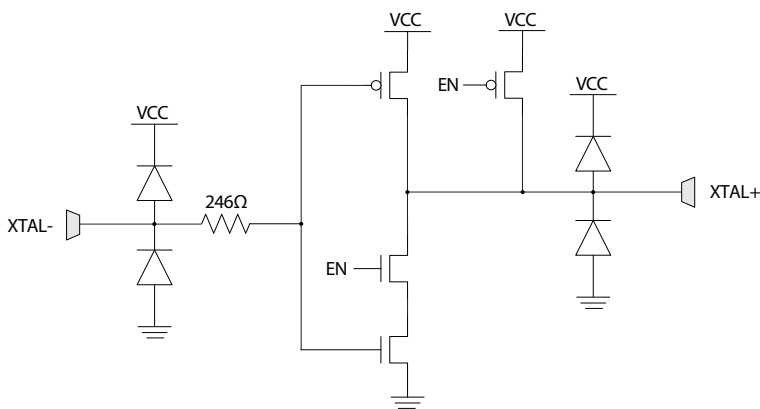

Figure 3-5: High-speed Crystal Oscillator I/O (XTAL-, XTAL+)

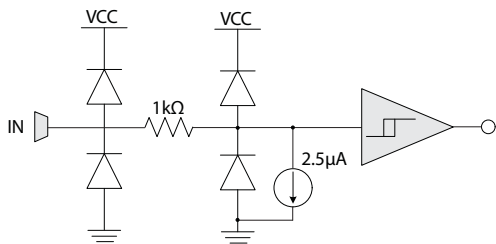

Figure 3-6: SPI Inputs, EQ/De-Emphasis Control ($\overline{CS}/EQ1_EN$, $SCK/DE1_EN$, $SDI/EQ0_EN$)

4. Detailed Description

The GS2965 is a multi-standard reclocker for serial digital SDTV signals operating at 270Mb/s, and HDTV signals operating at 1.485Gb/s, 1.485/1.001Gb/s, 2.97Gb/s and 2.97/1.001Gb/s.

4.1 Serial Data Input

The GS2965 features two differential input buffers.

The serial data input signal is connected to the DDI0/ $\overline{\text{DDI0}}$ and DDI1/ $\overline{\text{DDI1}}$ input pins of the device.

Input signals can be single-ended or differential, DC or AC-coupled.

The input circuit is self-biasing, to allow for simple AC or DC-coupling of input signals to the device.

The serial digital data inputs are also compatible when DC-coupled with LVPECL or CML differential outputs from crosspoint switches which operate from 3.3V or 2.5V supplies. This includes but is not limited to: GS2974A, GS2974B, and GS2984 equalizers.

4.2 Modes of Operation

The GS2965 has two modes of operation: Legacy Mode ($\overline{\text{HIF}} = \text{HIGH}$) and SPI Mode ($\overline{\text{HIF}} = \text{LOW}$).

In Legacy Mode, chip functions are controlled via pins only, and offers limited control of input equalization.

In SPI mode, access is gained to extended digital controls like: Bypass, Autobypass, Auto/Manual selection, Control status inputs or outputs, changes to KBB settings, additional EQ and DE settings as well as access to additional features such as LOS adjustment, polarity invert, auto-mute, etc.

4.3 Input Trace Equalization

The GS2965 features adjustable trace equalization to compensate for PCB trace dielectric losses at 1.5GHz.

The trace equalization has three peak-gain settings. The maximum peak gain value is optimized for compensating the high-frequency losses associated with 25 inches of 5-mil stripline in FR4 material. For boards with different striplines or materials, users can experiment to find the EQ setting which optimizes their system performance.

These settings are accessible via the serial host interface.

Each serial digital input, DDI, $\overline{\text{DDI}}$, includes a pin EQn_EN to turn its trace equalizer on or off. When a pin EQn_EN is tied LOW or left unconnected, the trace equalization for input n is set to the Low Range.

When an EQn_EN pin is tied HIGH, and input n is selected, the trace equalization for input n is set to the Medium Range.

Table 4-1: Input Trace Equalization Operation

EQn_EN Setting	Trace Equalization Range
LOW	Low
HIGH	Medium

The default peak-gain setting upon power-up is optimized for compensating the high-frequency losses associated with approximately 10 inches of 5-mil stripline in FR4 material.

The EQn_EN pins are multiplexed with the serial host interface pins. The EQn_EN functionality is enabled when pin $\overline{\text{HIF}}$ is tied high, as shown in [Table 4-2](#):

Table 4-2: EQn_EN Pins Multiplexed

Pin	Function
SDI/EQ0_EN	Active-high logic input to enable trace-equalization for high-speed input channel 0.
$\overline{\text{CS}}$ /EQ1_EN	Active-high logic input to enable trace-equalization for high-speed input channel 1.

4.4 2:1 Input Mux

The GS2965 incorporates a 2:1 input mux, which allows the connection of two independent streams of video/data. There are two differential inputs (DDI[1:0] / $\overline{\text{DDI}}$ [1:0]). The active channel can be selected via the DDI_SEL[1:0] registers as shown in [Table 4-3](#).

Table 4-3: Input Selection Table

DDI_SEL[1:0]	Selected Input
00	DDI0*
01	NOT VALID
10	NOT VALID
11	DDI1

* - Power up default

Active circuitry associated with the input buffers and trace EQ can only be turned on for the selected input. Inputs which are not selected have their input buffers and trace EQs turned OFF to save power. Unused inputs can be either left floating, or tied to VCC.

4.5 Crystal Buffer

The GS2965 features a crystal buffer supporting a Gennum recommended external 27MHz crystal. The GS2965 requires an external 27MHz reference clock for correct operation. This reference clock is generated by connecting a crystal to the XTAL- and XTAL+ pins of the device.

Alternately, a 27MHz external clock source can be connected to the XTAL- pin of the device, while the XTAL+ pin should be left floating.

4.6 LOS (Loss Of Signal) Detection

The LOS (Loss Of Signal) status pin is an active-high output that indicates when the serial digital input signal selected at the 2:1 input mux is invalid. In order for this output to be asserted, transitions must not be present for a period of $t_{LA} = 5 - 10\mu s$. After this output has been asserted, LOS will de-assert within $t_{LD} = 0 - 5\mu s$ after the appearance of a transition at the DDlx input. See [Figure 4-1](#).

This signal is HIGH (signal lost), when the number of data edges within a window is below a defined threshold. The output is automatically muted when LOS is detected.

This signal is LOW (signal valid), when the number of data edges within a window is above a defined threshold. See [Table 4-4](#).

Table 4-4: LOS Operation

LOS	Signal
HIGH	Invalid
LOW	Valid

The LOS function is operational for all operating modes of the device.

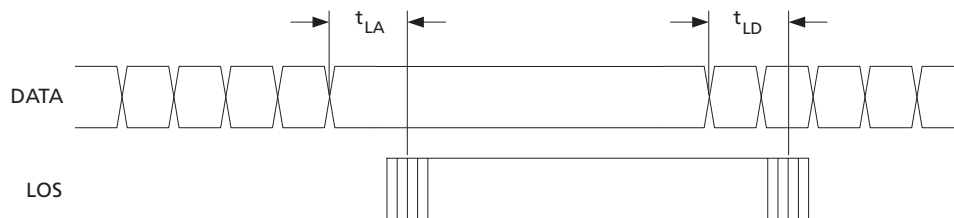

Figure 4-1: LOS Signal Timing

The LOS mode can be selected using the host interface, in register TOP_1. The LOS detector has two major modes. In legacy mode, a simple edge-based detector is used to

monitor the received signal at the output of the data slicer. Since the incoming signal has undergone considerable gain by this point, the legacy detector can be more susceptible to false de-assertion of LOS for unused channels which experience significant cross-talk from adjacent active channels.

The new LOS detector uses a measure of both signal amplitude and duration to minimize false detection of the impulse like signals that are characteristic of cross-talk. In this mode, the signal is tapped off at the output of the equalizer stage, prior to the high gain buffers.

The threshold setting within the detector can be adjusted to increase or decrease its sensitivity. Gennum recommends using the least sensitive threshold level. This provides the most margin against false de-assertion of LOS.

Table 4-5: Suggested LOS Threshold Settings

		LOS Detection Method Select	LOS Threshold Adjust
Input Signal Amplitude	>250mV _{ppd}	0x1	0x0
	200mV _{ppd} to 250mV _{ppd}	0x1	0x1
	150mV _{ppd} to 200mV _{ppd}	0x1	0x2
	<150mV _{ppd}	0x1 or 0x0	0x3

The LOS mode can be selected by using the host interface, in register TOP_1 (address 0x02).

4.7 Serial Digital Reclocker

The output of the Equalizer is fed to the reclocker. The function of the reclocker is to re-time the input signal and to generate system clocks.

The reclocker operates at three data rates; 2.97Gb/s, 1.485Gb/s and 270Mb/s, and provides a minimum input jitter tolerance of 0.8UI to square-wave-modulated jitter at these rates.

When there is no serial input signal, the internal clock maintains a frequency close to the expected incoming data rate by locking to the external reference crystal.

4.8 Lock Detection

The lock detect block indicates, via the active-high LOCKED signal, when the device has achieved lock to the incoming data stream.

The lock logic within the GS2965 includes a system that monitors the frequency and the phase of the incoming data, as well as a monitor to detect harmonic lock.

Table 4-6: Lock Operation

LOCKED	Status
HIGH	Locked
LOW	Not locked

The LOCKED output signal is also available via the host interface.

4.8.1 Lock Detect and Asynchronous Lock

The reference crystal is used to assist the PLL in achieving a short lock time. The lock detection algorithm is a continuous process, which begins at device power up or after a system reset, and continues until the device is powered down.

The asynchronous lock time is defined as the time it takes the device to lock when a video signal is first applied to the serial digital inputs, or when the digital video signal rate changes.

The synchronous lock time is defined as the time it takes the device to lock to a signal which has been momentarily interrupted.

4.9 Serial Data Output

The GS2965 features two current-mode differential output drivers, each capable of driving a maximum of 800mV_{pp} differential, into an external 100Ω differential load.

Each of the GS2965's output buffers include two on-chip, 50Ω termination resistors.

4.9.1 Output Signal Interface Levels

The serial digital outputs of the GS2965 are compatible when DC-coupled with all Gennum serial digital interface products that feature a differential LVPECL or CML receiver designed for SDI applications and operate from 3.3V or 2.5V supplies. This includes but is not limited to: GS2978, GS2988, and GS2989.

The serial digital data inputs are also compatible when DC-coupled with LVPECL or CML differential outputs from crosspoint switches which operate from 3.3V or 2.5V supplies. This includes but is not limited to: GS2974A, GS2974B, and GS2984 equalizers.

4.9.2 Adjustable Output Swing

It is possible, via the host interface, to force the output swing to 400mV_{pp} or 800mV_{pp} differential, when the outputs are terminated with 50Ω loads.

The default output swing upon power-up is 400mV_{pp} differential.

4.9.3 Output De-emphasis

The GS2965 features adjustable output de-emphasis to compensate for PCB trace dielectric losses.

The output de-emphasis has eight settings, evenly distributed from a minimum of 0dB (output de-emphasis OFF) to a peak de-emphasis setting that is optimized for compensating the high-frequency losses associated with approximately 20 inches of 5-mil stripline in FR4 material. These settings are accessible via the serial host interface.

The action of the de-emphasis settings is to attenuate the trailing edge of the output data waveform relative to the output swings set through the host interface.

De-emphasis is turned OFF when in Bypass mode.

The default de-emphasis setting upon power-up is 0dB (OFF).

NOTE: Changing the de-emphasis setting will vary both V1 & V2 (see Figure 4-2).

The DEn_EN pins are multiplexed with the serial host interface pins. The DEn_EN functionality is enabled when pin $\overline{\text{HIF}}$ is tied HIGH, as shown in Table 4-7:

Table 4-7: DEn_EN Pins Multiplexed

Pin	Function
SDO/DE0_EN	Active-high logic input to enable de-emphasis for high-speed input channel 0.
SCK/DE1_EN	Active-high logic input to enable de-emphasis for high-speed input channel 1.

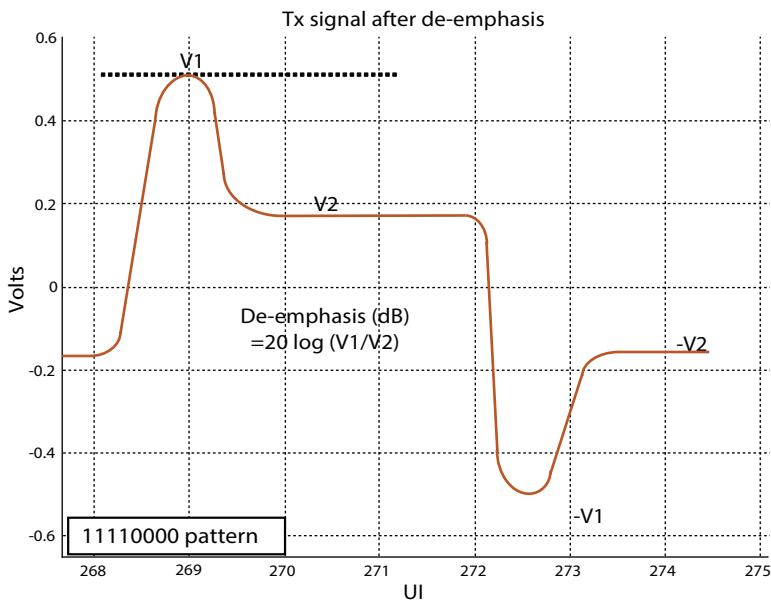

Figure 4-2: De-emphasis Waveform

4.10 Automatic and Manual Data Rate Selection

The GS2965 can be configured to manually lock to a specific data rate or automatically search for and lock to the incoming data rate. The default configuration is AUTO mode. This can be changed via the host interface.

In AUTO mode, the SS[1:0] registers become read only, and the bit pattern indicates the data rate at which the PLL is currently locked to (or previously locked to). The search algorithm cycles through the data rates and starts over if that data rate is not found (see Figure 4-3).

A “search algorithm” cycles through the supported data rates until lock is achieved, as shown in Figure 4-3 below.

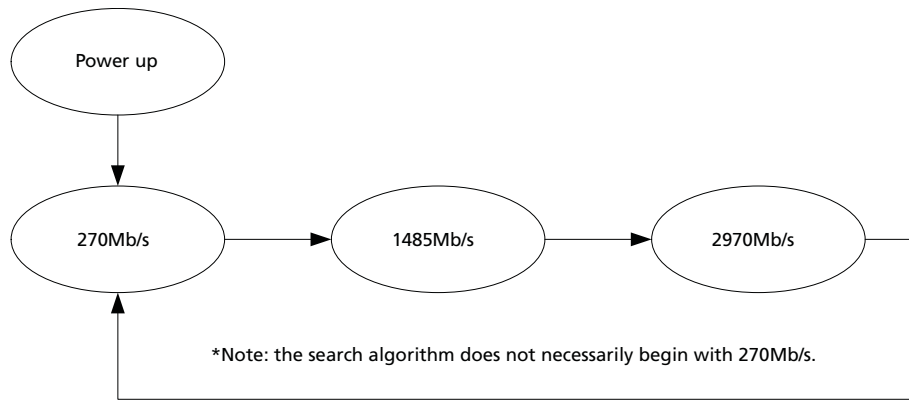

Figure 4-3: GS2965 Automatic Mode Search Algorithm

In MANUAL mode, the SS[1:0] registers become read or write accessible, and the data rate can be programmed. In this mode, the search algorithm is disabled and the GS2965's PLL will only lock to the data rate selected in accordance with Table 4-8.

Table 4-8: Data Rate Indication/Selection Bit Pattern

SS[1:0]	Data Rate (Mb/s)
0	Reserved
1	270
2	1485 or 1485/1.001
3	2970 or 2970/1.001

4.11 SD/HD Indication

The SD/HD signal indicates the output data rate of the device and can be connected to the SD/HD input pin of dual slew rate cable drivers such as the GS2988.

When this signal is HIGH, the data rate is 270Mb/s. This signal is LOW for all other data rates.

This signal is also LOW when the device is operating in bypass mode (Auto-bypass and User-bypass).

The $\overline{SD}/\overline{HD}$ signal is LOW when the device is not locked.

4.12 Bypass Mode

In bypass mode, the GS2965 passes the data at the inputs, directly to the output. There are two register bits that control the bypass function: BYPASS and AUTOBYPASS.

The BYPASS bit is an active-high signal which forces the GS2965 into bypass mode for as long as the bit is asserted HIGH.

The AUTOBYPASS bit is an active-high signal that places the GS2965 into bypass mode only when the PLL has not locked to a data rate.

Table 4-9: Bypass Modes

Bypass	Autobypass	Device Operation
HIGH	X	Bypass Mode
LOW	HIGH	Bypass Mode if the PLL has not locked to a data rate
LOW	LOW	Power-up default. Normal Operation, part always tries to lock to the incoming data stream.

Note that if BYPASS is HIGH, this will override the AUTOBYPASS functionality.

When the GS2965's PLL is not locked and BYPASS = LOW and AUTOBYPASS = LOW, the serial digital output $\overline{DDO}/\overline{DDO}$ will produce invalid data.

The AUTOBYPASS function will bypass unsupported (non-reclocked) SMPTE SDI signal rates without producing bit errors: 143Mb/s, 177Mb/s, 360Mb/s, 540Mb/s.

4.13 DVB-ASI

The GS2965 also reclocks DVB-ASI signals at 270Mb/s. In auto mode, the device will automatically lock to the incoming 270Mb/s signal. In manual mode, the SS[1:0] bits must be set to 01 (270Mb/s) to ensure proper operation.

4.14 Output Mute and Data/Clock Output Selection

The $\overline{DATA_MUTE}$ register is provided to allow muting of the serial digital data output.

Setting $\overline{DATA_MUTE} = \text{LOW}$ will force the serial digital outputs $\overline{DDO}/\overline{DDO}$ to mute (statically latch HIGH) under all conditions and operating modes.

The $\overline{\text{DDO1_DISABLE}}$ register is provided to allow the second data/clock output to be powered down.

When $\overline{\text{DDO1_DISABLE}}$ is set LOW, the serial digital clock outputs DDO1/RCO and $\overline{\text{DDO1/RCO}}$ are muted and the driver is powered-down.

The $\text{DATA}/\overline{\text{CLOCK}}$ register is provided to allow the second output to emit a copy of the relocked serial data or the recovered clock.

Table 4-10: Configuration of GS2965 Output Drivers and Mute/Disable Pins

DATA_MUTE	DDO1_DISABLE	$\text{DATA}/\overline{\text{CLOCK}}$	DDO0	DDO1/RCO
1	1	0	DATA	CLOCK
1	1	1	DATA	DATA
0	1	0	MUTE	CLOCK
0	1	1	MUTE	MUTE
1	0	X	DATA	Power down
0	0	X	MUTE	Power down

4.15 Host Interface

4.15.1 Introduction

The GS2965 offers a Serial Peripheral Interface (SPI) to access advanced features and programmability. The polarity of the $\overline{\text{HIF}}$ pin tells the GS2965 whether or not the host interface is active ($\overline{\text{HIF}} = 0$) or in legacy mode ($\overline{\text{HIF}} = 1$).

Using the host interface, it is possible to override the control pin settings, and such settings will persist until the device has been powered-down and/or reset. The host interface is capable of reading hard-wired pin configuration, pin override settings and the values of all status monitoring pins.

There is an optional 3-state feature available in the Control Status Registers (CSR) that puts the SPI SDO to high-impedance when it's not being used (Register: TOP_1 , bit: 2).

The maximum operating speed of the SPI is 10MHz.

4.15.2 Legacy Mode & Start-up

In legacy mode, basic configuration of the device (including a subset of equalizer and de-emphasis settings) are available at the pin level. In this mode, register settings are automatically set to default so that the GS2965 is live at power-up.

4.15.3 Host Interface Mode & Start-up

In host interface mode, the user gains access to Control and Status Registers (CSRs) that manage advanced features. In this mode, equalizer and de-emphasis settings are set through the CSR.

The SPI control port is functional at start-up without the need for a separate, external reset signal. However, all internal registers must be set to their default state by issuing a required Reset Command via the SPI.

This is done by setting the \bar{R} bit (reset) LOW in the command word. This will guarantee the CSR will not start up in a random state.

A simple way to issue the required reset of the CSR is to hold the slave device's SDI input LOW for an entire 64 cycle WRITE communication. Details of the WRITE operation are found in section 4.15.6 below.

4.15.4 Clock & Data Timing

The SPI signals are Serial Data Input (SDI), Serial Data Output (SDO), active-low Chip Select (\bar{CS}), and Serial Clock Input (SCK). The host interface operates in SPI Mode 0, i.e. the SDI input will latch data in on the rising edge of SCK. The SDO data output will transition on falling edges of SCK. Data is transmitted or received on the SPI port MSB first LSB last.

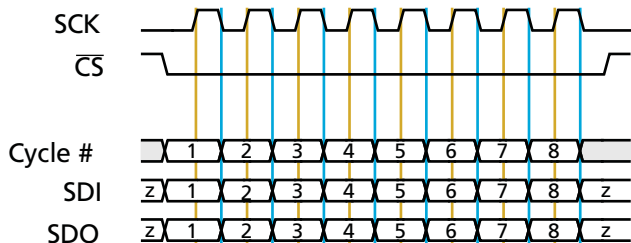

Figure 4-4: Data Clock Alignment

4.15.5 Single Device Operation

For applications with a single device or applications with multiple devices where daisy chaining is not desired, the chain position bits $C[6:0]$ should always be set to 0. As a by-product of the daisy chaining feature, Read and Write operations experience a 32 SCK cycle latency from SDI to SDO. For more details on daisy-chaining, refer to [Section 4.15.8 on page 29](#).

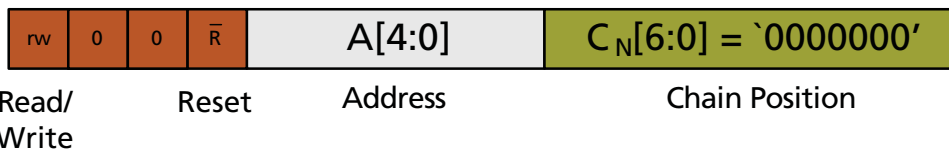

Figure 4-5: 16-bit Command Format

4.15.6 Write Operation - Single Device

A Write operation consists of a 16-bit command word and a 16-bit data word, followed by 32 cycles with the slave SDI held HIGH. When writing to a single non-daisy chained device, the following format should be used:

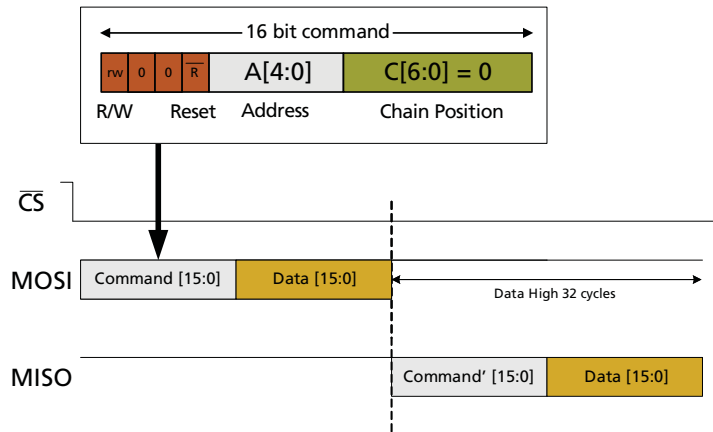

Figure 4-6: Single Device Write

1. At power-up, the device should be reset by setting the \overline{R} bit LOW. A simple way to accomplish a reset is to hold the slave SDI line LOW for an entire 64 cycle communication.
2. For a Write operation, the r/w bit should be set to 0.
3. The 2nd and 3rd bits are reserved, and should be set to 0.
4. The \overline{R} bit should always be set HIGH for a normal Write operation.
5. Refer to the Register Map for information on Address and Data bits.
6. The slave SDI line should be held HIGH for 32 cycles before de-asserting \overline{CS} .

4.15.7 Read Operation - Single Device

For Reading from a device the following format should be used:

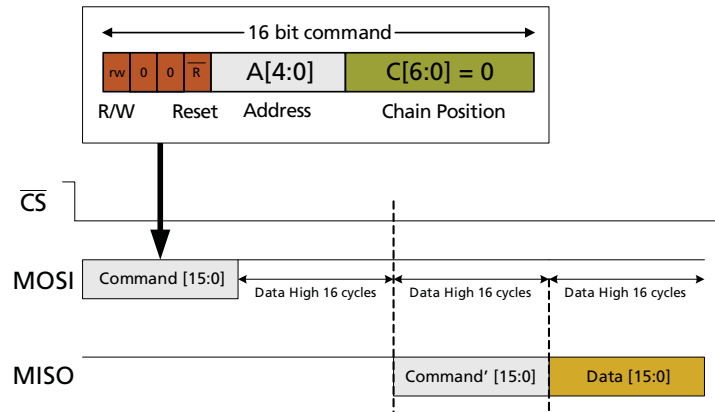

Figure 4-7: Single Device Read

1. For a Read operation, the r/w bit should be set to 1.
2. The 2nd and 3rd bits are reserved and should be set to 0.
3. The \bar{R} bit should always be set HIGH for a normal Read Operation.
4. Data Out at the slave SDO will appear after holding the slave SDI line HIGH for 32 cycles.
5. The 16-bit data is now available on the slave SDO line.

Detailed timing diagrams for Write and Read can be seen in [Figure 4-8](#) and [Figure 4-9](#).

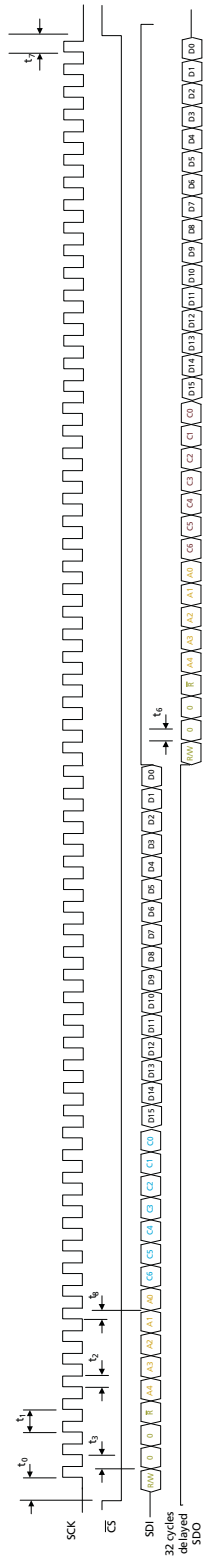

Figure 4-8: SPI Write Timing

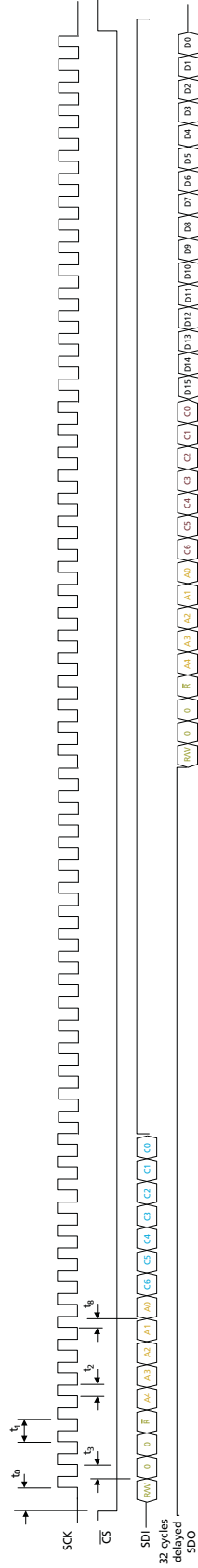

Figure 4-9: SPI Read Timing

Table 4-11: SPI Interface Specifications

Parameter	Symbol	Conditions	Min	Typ	Max	Units
\overline{CS}_n LOW before HOST_CLK rising edge	t_0		1.5	–	–	ns
HOST_CLK period	t_1		100	–	–	ns
HOST_CLK duty cycle	t_2		40	50	60	%
Input data setup time	t_3	50% levels	1.5	–	–	ns
Output hold time (15pF load)	t_6		1.5	–	–	ns
\overline{CS}_n HIGH after last HOST_CLK rising edge	t_7		75% of HOST_CLK period	–	–	ns
Input data hold time	t_8		1.5	–	–	ns

4.15.8 Daisy Chain Operation

For applications with multiple GS2965 devices, it is possible to daisy-chain up to 127 parts in serial. In this configuration, the first device SDI should be connected to the SPI Master SDO. The serial data output of each device is then connected to the serial data input of the following device, and so on. The last device's SDO connects to the Master's SDI. Connecting devices in serial reduces the number of I/O ports required by the master by removing the need for additional chip select lines.

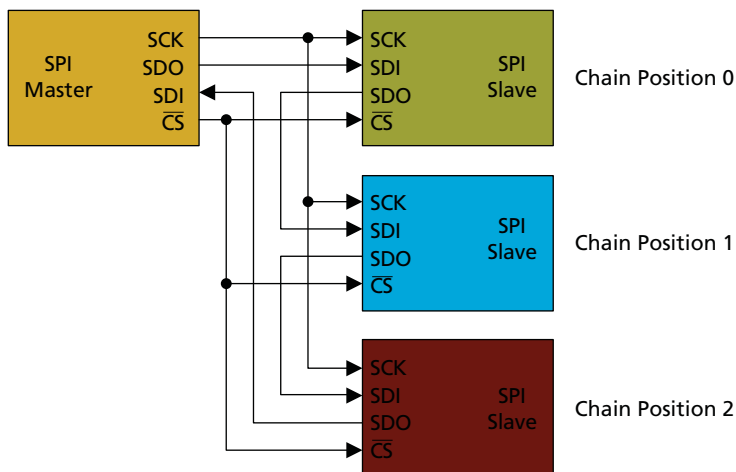

Figure 4-10: Daisy Chained SPI Bus

The position of each GS2965 device in the serial chain is referred to as its Chain Position, with 0 corresponding to the first device. The Chain Position in the SPI command word is decoded by each slave to know which device the master is talking to.

Each GS2965 slave is designed to output a replica of what it receives at its input after a delay of 32 cycles. The Chain Position part of the command is decremented by one in the duplicated command word at the output. Each device in the chain will only execute the issued command if it verifies that the current chain position is set to 0.

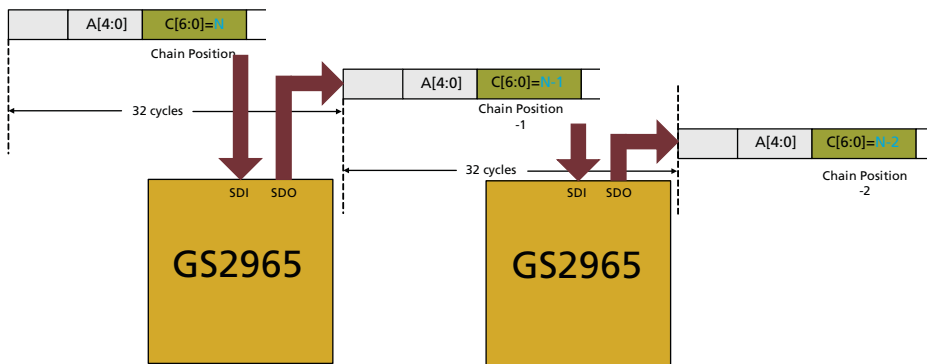

Figure 4-11: Chain Position Decoding

4.15.9 Read & Write Operation - Daisy Chained Devices

In a serial daisy chain configuration, Read and/or Write operations can be performed to multiple devices in the chain via consecutive operations. Figure 4-12 below shows a simple 3 device configuration.

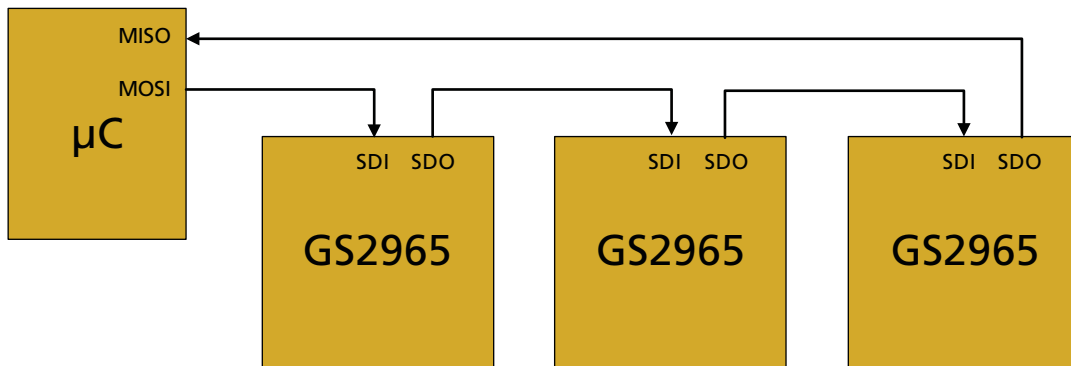

Figure 4-12: Three Devices in Daisy Chain Configuration

4.15.10 Writing to all Devices

When writing to all devices in the chain, a Write Command and corresponding Data is required for each device. When the devices are being configured in the same way, all of them will have the same command and data with the exception of the Chain Position bits. This example assumes a 3-device daisy chain. A command is issued to the last device in the chain first, although it is possible to talk to the devices in any order.

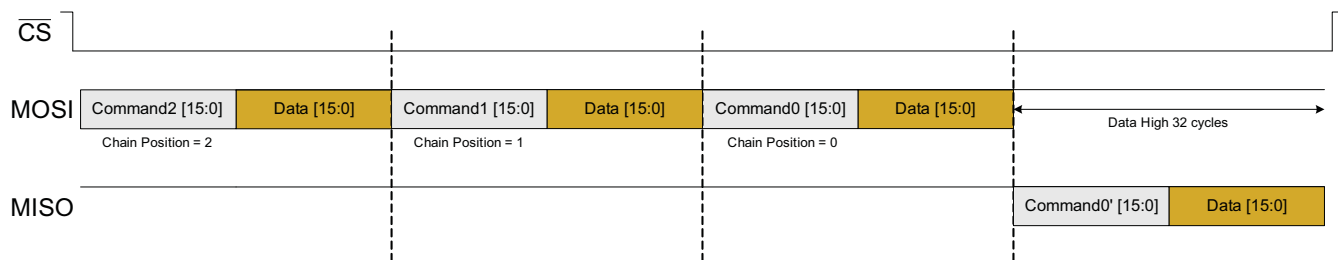

Figure 4-13: Daisy Chain Write

1. The first command issued in time is the command for the last device in the chain (chain position = 2). When the first device receives this command it will recognize that the Chain Position is 2 and will not execute the command. It will duplicate the command and data word at its output and decrement the Chain Position by one.
2. Consecutive commands are issued for each device in the chain as shown.

4.15.11 Writing to a Single Device in the Chain

The following example shows how to write to a single device in a chain:

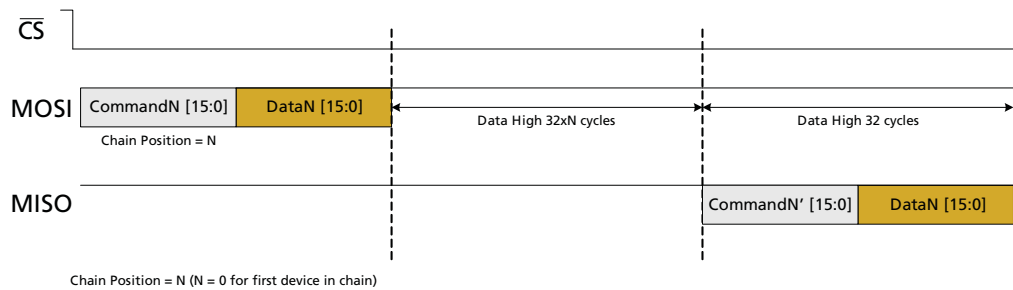

Figure 4-14: Daisy Chain Write to a Single Device

1. The command is issued to Chain Position N.
2. $32 \times N$ cycles are required to shift the command through N devices. The device at chain position N executes the command.
3. 32 additional cycles are needed to complete the communication.

4.15.12 Reading from all Devices

To read from all devices in the chain, a Read command is issued for each device consecutively. After each command, the data is held HIGH for 16 cycles. Once a device recognizes it is being talked to, it will output data from the register requested. Clock needs to be applied to cycle the output data through all devices in the chain.

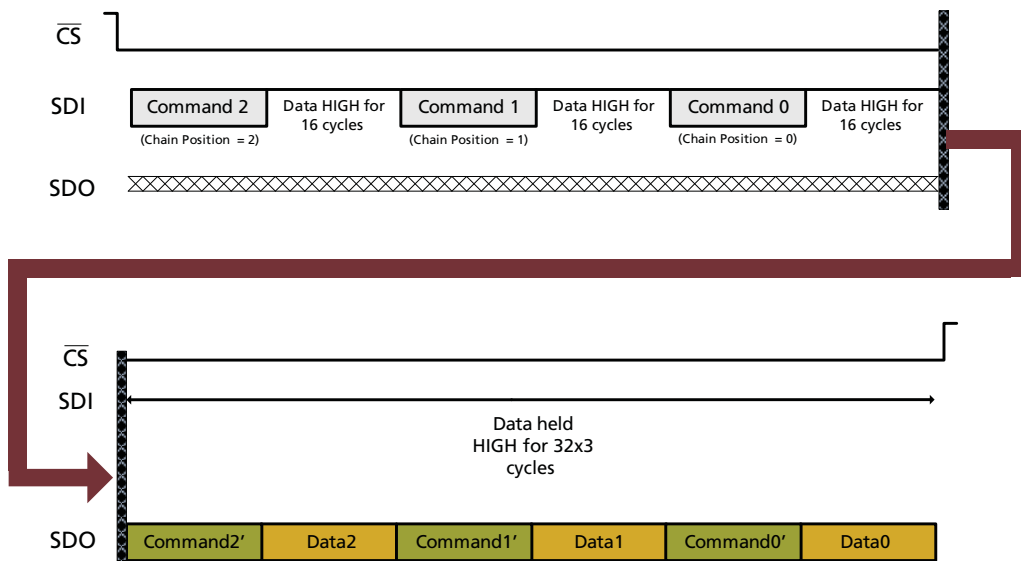

Figure 4-15: Daisy Chain Read

1. Read command is issued to the last device in the chain, followed by Read commands to the lower chain positions.
2. Clock is applied to cycle the output data through the chain.
3. Command2' refers to the altered or decremented Command2.

4.15.13 Reading from a Single Device in the Chain

The following example shows how to read from a single device in a chain:

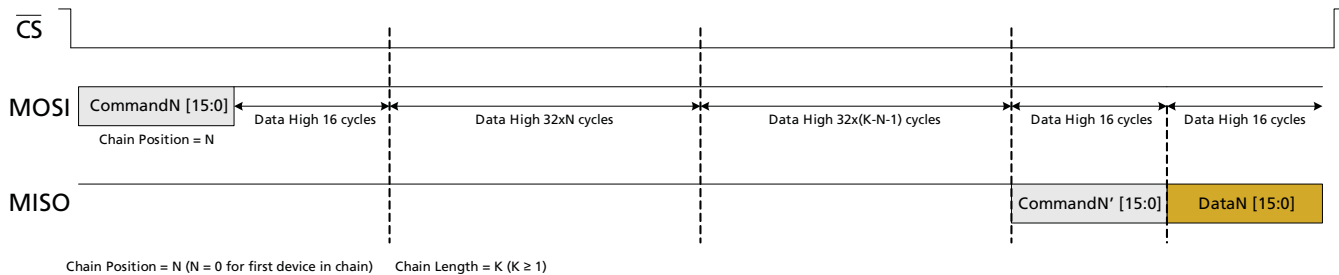

Figure 4-16: Daisy Chain Read from a Single Device

1. Read command and 16 cycles of data held HIGH are issued to chain position N.
2. $32 \times N$ cycles are applied with data HIGH to cycle the command through N devices in the chain (NOTE: N is 0 for first device in chain). Device N executes the command.
3. With K representing the total number of devices in the chain, $32 \times (K - N - 1)$ cycles are applied to bring the return data through the rest of the chain.
4. 16 additional cycles are applied until the data from device N is available on the Master SDI.

4.15.14 Host Register Map

Table 4-12: Host Register Map

Register Name	Register Address	Bit Position	Access	Function	Default Value	Valid Range	Comments
		15:10	RW		Reserved.		
		9	RW	Input Attenuation Enable (ATTEN_EN)	0x0	0 or 1	Enable for input signals above 1Vpp differential
		8	RW	Equalizer Offset Correction Enable	0x1	0 or 1	Recommend always on
		7	RW	Equalizer Gain Setting for DDI1	0x0	0 or 1	See supplementary table below
		6 - 5	RW	Unused	0x0	0 or 1	–
		4	RW	Equalizer Gain Setting for DDI0	0x00	0 or 1	See supplementary table below
EQ_1	0x00	3	RW	Equalizer Enable for DDI1	0x00	0 or 1	See supplementary table below
		2 - 1	RW	Unused	0x00	0 or 1	–
		0	RW	Equalizer Enable for DDI0	0x00	0 or 1	See supplementary table below
Equalizer Decode Logic							
		EQ_EN	EQ_GAIN	EQ Setting	Recommended Trace Lengths		
		0	0	LOW	0 to 10 inches of FR4		
		0	1	LOW	0 to 10 inches of FR4		
		1	0	MED	10 to 20 inches of FR4		
		1	1	HIGH	20 or more inches of FR4		
		15:10	RW	Unused	0x0	0 or 1	–
		9	RW	Amplitude Control for DDO1	0x1	0 or 1	0 = 800mV swing 1 = 400mV swing
DRIVER_1	0x01	8	RW	Amplitude Control for DDO0	0x1	0 or 1	0 = 800mV swing 1 = 400mV swing
		7:5	RW	De-Emphasis Boost Amplitude Control for DDO1	0x2	0x0 to 0x7	0x0 = Lowest Setting 0x7 = Highest Setting

Table 4-12: Host Register Map (Continued)

Register Name	Register Address	Bit Position	Access	Function	Default Value	Valid Range	Comments
DRIVER_1	0x01	4:2	RW	De-Emphasis Boost Amplitude Control for DDO0	0x2	0x0 to 0x7	0x0 = Lowest Setting 0x7 = Highest Setting
		1	RW	De-Emphasis Enable for DDO1	0x0	0 or 1	–
		0	RW	De-Emphasis Enable for DDO0	0x0	0 or 1	–
		15:9	RW	Reserved.			
		8:7	RW	LOS Threshold Adjust	0x0	0x0 to 0x3	0x0 = least sensitive 0x3 = most sensitive
TOP_1	0x02	6:5	RW	LOS Detection Method Select	0x0	0x0 to 0x2	0x0 = legacy edge detectionmethod 0x1 = new signal strength detectionmethod 0x2 = dual detection method: both must detect signal present for LOS to be LOW
		4	RW	LOS Mute Enable	0x0	0 or 1	When enabled the output will automatically mute if LOS is HIGH
		3	RW	Power Down	0x0	0 or 1	Chip powers down when asserted
		2	RW	Tri-State Enable for SPI Output	0x0	0 or 1	When enabled the SPI SDO will be high Z when \overline{CS} is not selected
		1	RW	Crystal Buffer Disable	0x0	0 or 1	0 = Enabled 1 = Disabled
		0	RW	Data Polarity Invert	0x0	0 or 1	0 = Not Inverted 1 = Inverted
0X03 to 0X0B		Reserved.					

Table 4-12: Host Register Map (Continued)

Register Name	Register Address	Bit Position	Access	Function	Default Value	Valid Range	Comments
PIN_OR_1	0x0C	15:13	RW	Unused	0x0	0 or 1	–
		12	RW	DATA/ $\overline{\text{CLOCK}}$	0x0	0 or 1	–
		11	RW	$\overline{\text{DDO1_DISABLE}}$	0x0	0 or 1	–
		10	RW	$\overline{\text{DATA_MUTE}}$	0x0	0 or 1	–
		9:8	RW	KBB	0x0	0x0, 0x2 or 0x3	Equivalent settings: 0x0 = KBB to ground 0x2 = KBB floating 0x3 = KBB to VCC
		7	RW	SS1	0x0	0 or 1	–
		6	RW	SS0	0x0	0 or 1	–
		5	RW	$\overline{\text{AUTO/MAN}}$	0x0	0 or 1	–
		4	RW	AUTOBYPASS	0x0	0 or 1	–
		3	RW	BYPASS	0x0	0 or 1	–
		2	RW	DDI_SEL1	0x0	0 or 1	-See Table 4-3 for valid values
		1	RW	DDI_SEL0	0x0	0 or 1	
		0	RW	Pin Override Enable	0x0	0 or 1	When enabled, input values will be taken from this register instead of package pins
STATUS_1	0x0D	15:4	RO	Reserved.	–	–	–
		3	RO	$\overline{\text{SD/H}\overline{\text{D}}}$	–	–	–
		2	RO	LOCKED	–	–	–
		1	RO	SS1	–	–	–
		0	RO	SS0	–	–	–
0x0E to 0x11		Reserved.					

4.16 Device Power Up

In host mode ($\overline{\text{HIF}}$ pin tied LOW), control & status registers (CSRs) may start up in a random state. There is a bit in the command word $\overline{\text{R}}$ which will reset the CSR when set LOW.

In non-host mode ($\overline{\text{HIF}}$ pin tied HIGH), the $\overline{\text{HIF}}$ pin is used to trigger an internal reset signal to place all registers in a deterministic, default state upon power-up.

In either host mode or non-host mode, other internal state machines (e.g. offset correction and PLL) automatically recover from any state at start-up with no reset required. It takes up to 1ms for the device to lock after start-up.

4.17 Standby

The purpose of Standby mode is to allow operating power to be reduced when the device's functionality is not required, and to have a rapid and simple transition to full operation when the device is required.

In order to achieve this, the device can be powered-down by writing a '1' to the 'Power Down' bit located in register address 0x02.

5. Typical Application Circuit

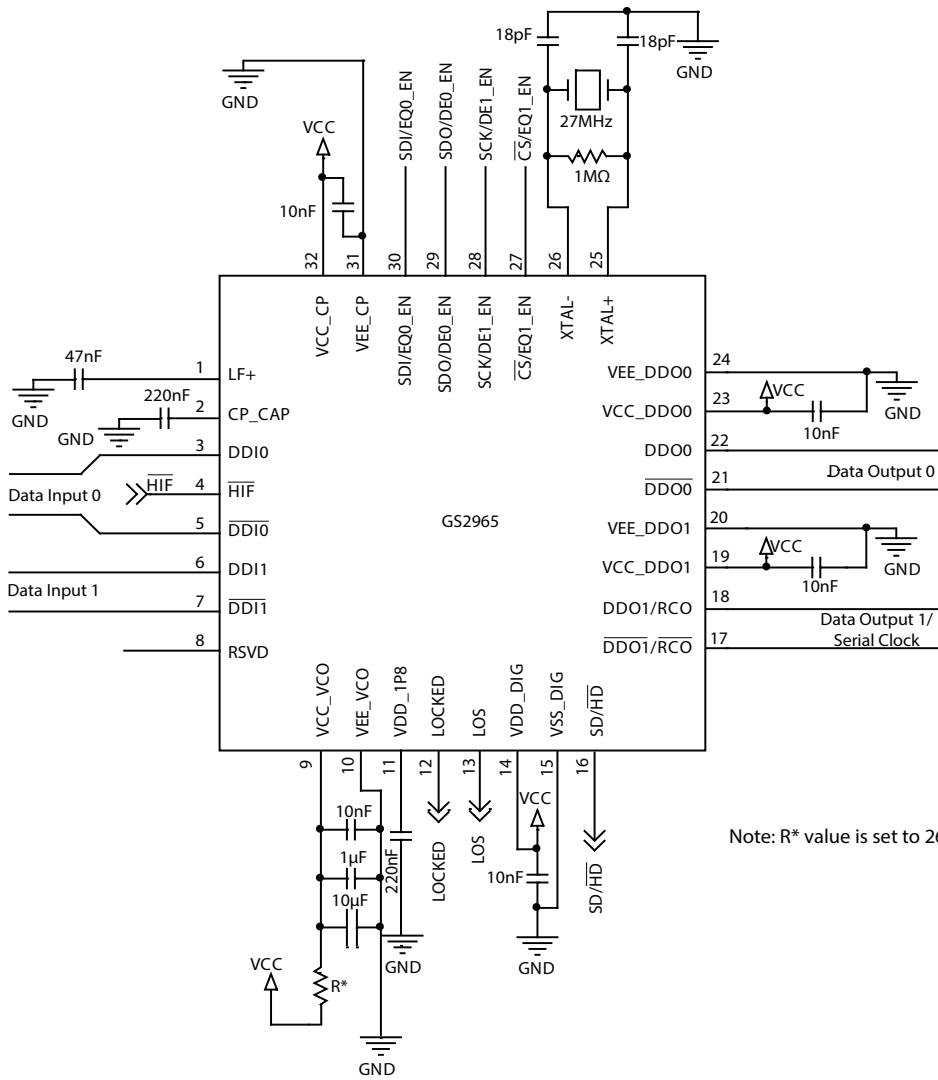

Figure 5-1: GS2965 Typical Application Circuit

6. Package and Ordering Information

6.1 Package Dimensions

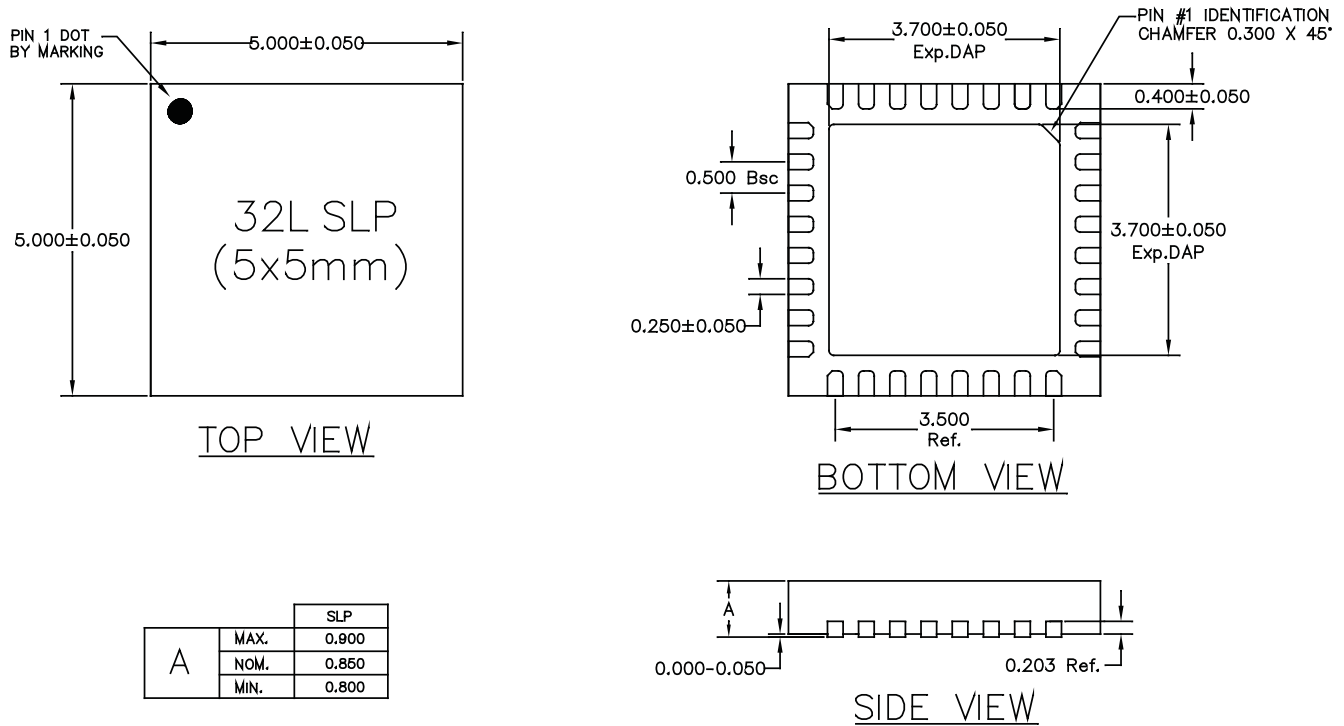

Figure 6-1: Package Dimensions

6.2 Recommended PCB Footprint

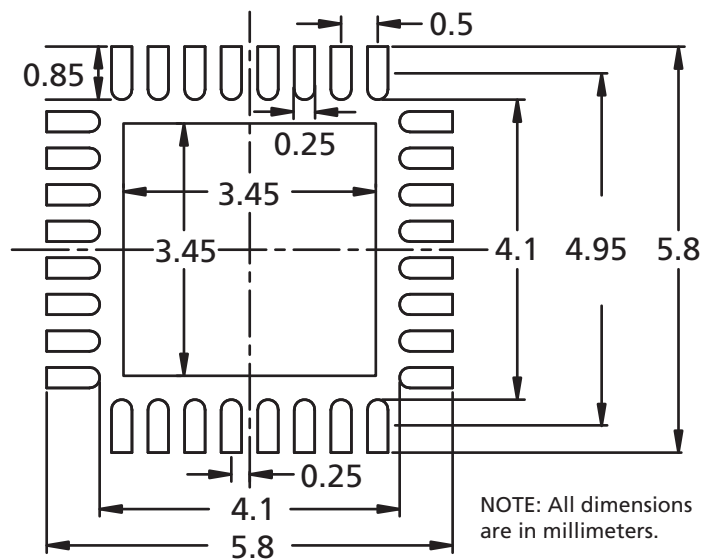

Figure 6-2: Recommended PCB Footprint

6.3 Packaging Data

Table 6-1: Packaging Data

Parameter	Value
Package Type	5mm x 5mm 32-pin QFN
Moisture Sensitivity Level	3
Junction to Case Thermal Resistance, θ_{j-c}	19.9°C/W
Junction to Air Thermal Resistance, θ_{j-a} (at zero airflow)	34.9°C/W
Junction to Board Thermal Resistance, θ_{j-b}	12.5°C/W
Psi, ψ	0.5°C/W
Pb-free and RoHS Compliant	Yes

6.4 Marking Diagram

Pin 1 ID

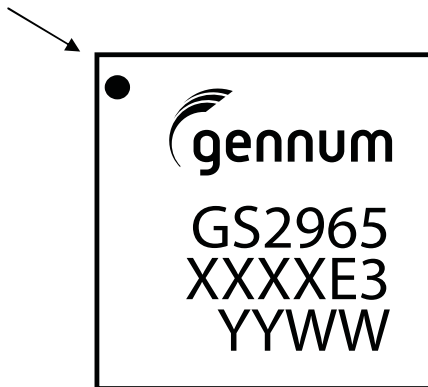

XXXX - Last 4 digits of Assembly lot
E3 - Pb-free & Green indicator
YYWW - Date Code

Figure 6-3: Marking Diagram

6.5 Solder Reflow Profile

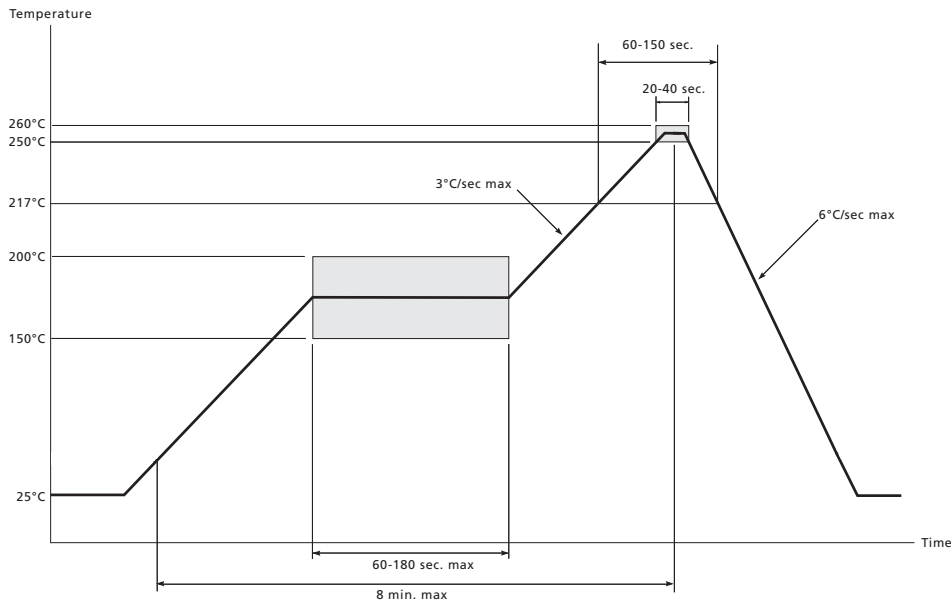

Figure 6-4: Maximum Pb-free Solder Reflow Profile

6.6 Ordering Information

Table 6-2: Ordering Information

Part Number	Package	Temperature Range
GS2965-INE3	Pb-free 32-pin QFN	-40°C to 85°C
GS2965-INTE3	Pb-free 32-pin QFN (250pc. tape and reel)	-40°C to 85°C
GS2965-INTE3Z	Pb-free 32-pin QFN (2.5k tape and reel)	-40°C to 85°C



IMPORTANT NOTICE

Information relating to this product and the application or design described herein is believed to be reliable, however such information is provided as a guide only and Semtech assumes no liability for any errors in this document, or for the application or design described herein. Semtech reserves the right to make changes to the product or this document at any time without notice. Buyers should obtain the latest relevant information before placing orders and should verify that such information is current and complete. Semtech warrants performance of its products to the specifications applicable at the time of sale, and all sales are made in accordance with Semtech's standard terms and conditions of sale.

SEMTECH PRODUCTS ARE NOT DESIGNED, INTENDED, AUTHORIZED OR WARRANTED TO BE SUITABLE FOR USE IN LIFE-SUPPORT APPLICATIONS, DEVICES OR SYSTEMS, OR IN NUCLEAR APPLICATIONS IN WHICH THE FAILURE COULD BE REASONABLY EXPECTED TO RESULT IN PERSONAL INJURY, LOSS OF LIFE OR SEVERE PROPERTY OR ENVIRONMENTAL DAMAGE. INCLUSION OF SEMTECH PRODUCTS IN SUCH APPLICATIONS IS UNDERSTOOD TO BE UNDERTAKEN SOLELY AT THE CUSTOMER'S OWN RISK. Should a customer purchase or use Semtech products for any such unauthorized application, the customer shall indemnify and hold Semtech and its officers, employees, subsidiaries, affiliates, and distributors harmless against all claims, costs damages and attorney fees which could arise.

The Semtech name and logo are registered trademarks of the Semtech Corporation. All other trademarks and trade names mentioned may be marks and names of Semtech or their respective companies. Semtech reserves the right to make changes to, or discontinue any products described in this document without further notice. Semtech makes no warranty, representation or guarantee, express or implied, regarding the suitability of its products for any particular purpose. All rights reserved.

© Semtech 2015

Contact Information

Semtech Corporation
200 Flynn Road, Camarillo, CA 93012
Phone: (805) 498-2111, Fax: (805) 498-3804
www.semtech.com