

## Low Noise Amplifier with Bypass Switch for LTE Low Band

### FEATURES

- Operating frequency 703MHz to 960MHz
- Noise figure(NF) =0.5dB
- High power gain =18dB
- Insertion Loss in bypass mode =3.5dB
- Gain mode IIP3inb =5dBm
- Gain mode input 1dB compression point =-9dBm
- Bypass mode input 1dB compression point = +12dBm
- Supply voltage: 1.5V to 3.1V
- Gain mode current 12.0mA
- Bypass mode current <1uA
- Input and output DC decoupled
- Requires only one input matching inductor
- Integrated matching for the output
- FCDFN 1.1mmX0.7mmX0.37mm -6L package
- 2kV HBM ESD protection (including RFIN and RFOUT pin)

### APPLICATIONS

- Cell phones
- Tablets
- Other RF front-end modules

### TYPICAL APPLICATION CIRCUIT

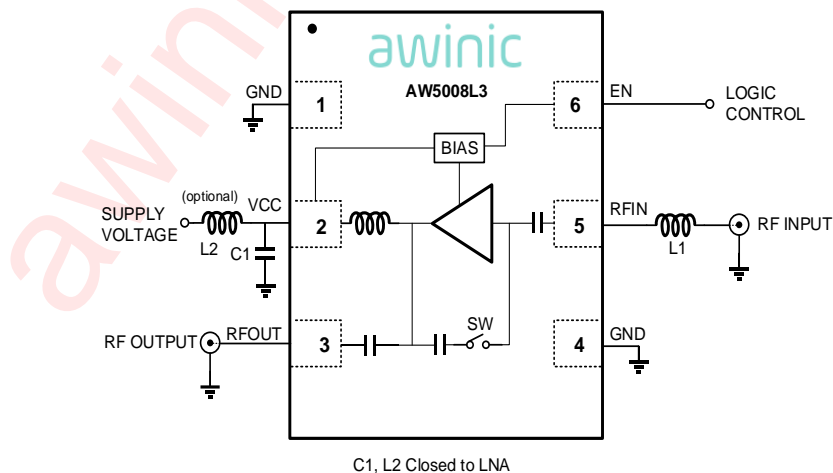

Figure 1 Typical Application Circuit of AW5008L3

All trademarks are the property of their respective owners.

### GENERAL DESCRIPTION

The AW5008L3 is a Low Noise Amplifier with bypass designed for LTE receiver applications. The AW5008L3 requires only one external input matching inductor, reduces assembly complexity and the PCB area, enabling a cost-effective solution.

The AW5008L3 achieves low noise figure, high linearity, high gain, over a wide range of supply voltages from 1.5V up to 3.1V. All these features make AW5008L3 an excellent choice for LTE LNA as it improves sensitivity with low noise figure and high gain, provides better immunity against jammer signals with high linearity, reduces filtering requirement of preceding stage and hence reduces the overall cost.

The AW5008L3 is available in a small lead-free, RoHS-Compliant, FCDFN 1.1mmX0.7mmX0.37 mm -6L package.

## PIN CONFIGURATION AND TOP MARK

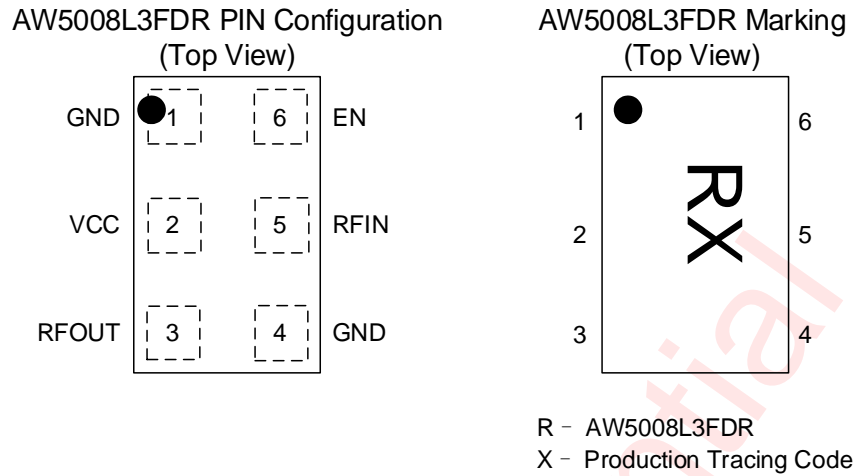

Figure 2 Pin Configuration and Top Mark

## PIN DEFINITION

No.	NAME	DESCRIPTION
1	GND	Ground.
2	VCC	Supply connection.
3	RFOUT	RF output
4	GND	Ground
5	RFIN	RF input
6	EN	EN (high level) supports 1.8V/2.8V IO with internal 150Kohm pull-down resistor.

## FUNCTIONAL BLOCK DIAGRAM

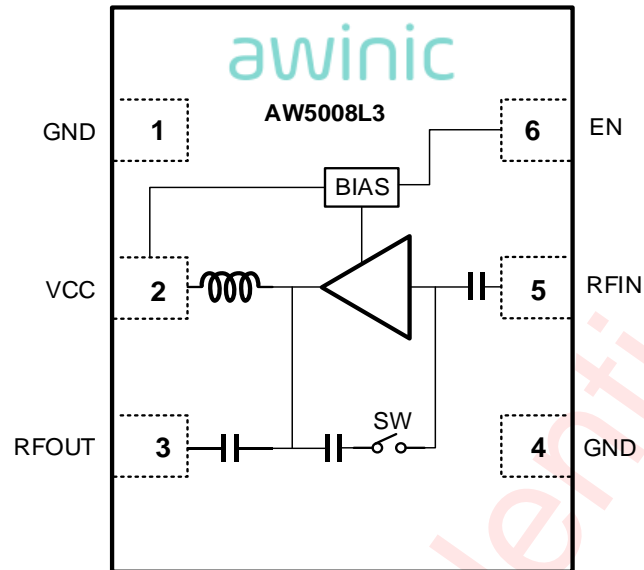

Figure 3 Functional Block Diagram

## ORDERING INFORMATION

Part Number	Temperature	Package	Marking	Moisture Sensitivity Level	Environmental Information	Delivery Form
AW5008L3FDR	-40°C~85°C	FCDFN 1.1mmX 0.7mm -6L	R	MSL1	ROHS+HF	3000 units/Tape & Reel

**ABSOLUTE MAXIMUM RATINGS**<sup>[1]</sup>

PARAMETERS	RANGE
Supply voltage VCC	-0.3V to 3.6V
EN pin voltage	-0.3V to 3.6V
Supply maximum current ICC	30mA
RF input power Pin	10dBm
Maximum Junction temperature T <sub>JMAX</sub>	150°C
Storage temperature T <sub>STG</sub>	-65°C to 150°C
Operating free-air temperature range	-40°C to 85°C
Lead temperature (Soldering 10 Seconds)	260°C
ESD <sup>[2]</sup>	
HBM	±2kV
CDM	±1kV
Latch-up	
Standard: JEDEC STANDARD NO.78D NOVEMBER 2011	+IT: +200mA -IT: -200mA

[1] Conditions out of those ranges listed in "absolute maximum ratings" may cause permanent damages to the device. In spite of the limits above, functional operation conditions of the device should within the ranges listed in "recommended operating conditions". Exposure to absolute-maximum-rated conditions for prolonged periods may affect device reliability.

[2] The human body model is a 100pF capacitor discharged through a 1.5kΩ resistor into each pin. Test method: MIL-STD-883J Method 3015.9. The CDM test method: JEDEC EIA/JESD22-C101F.

**ELECTRICAL CHARACTERISTICS**

TA=+25°C , V<sub>CC</sub>=2.8V, EN=2.8V, frequency=703MHz to 960MHz. Input matched to 50Ω using a 18nH<sup>[3]</sup> inductor in series. (unless otherwise noted).

Symbol	Parameter	Test Condition	Min	Typ	Max	Units
<b>DC Electrical Characteristic</b>						
VCC	Supply Voltage		1.5	-	3.1	V
VEN	Digital Input-Logic High		0.8	-	VCC	V
	Digital Input-Logic Low				0.45	V
<b>Gain Mode</b>						
ICC	Supply Current		7.7	11	12.5	mA
Gp	Power Gain	f=740MHz [4]	18.5	19.3	21.8	dB
		f=882MHz [5]	17.3	20.2	20.3	
		f=943MHz [6]	16.2	18.2	19.2	
RLin	Input Return Loss	f=740MHz [4]	6.3	7.4		dB
		f=882MHz [5]	9.6	11.5		
		f=943MHz [6]	8.4	10.9		
RLout	Output Return Loss	f=740MHz [4]	12.9	14.0		dB
		f=882MHz [5]	6.1	9.5		
		f=943MHz [6]	4.6	7.1		
ISL	Reverse Isolation	f=740MHz [4]	30	37.8		dB
		f=882MHz [5]	30	32.5		
		f=943MHz [6]	30	31.9		
NF	Noise Figure	f=740MHz [4][7]		0.5	0.7	dB
		f=882MHz [5][7]		0.55	0.8	
		f=943MHz [6][7]		0.65	0.9	
IP1dB	In-band input 1dB-compression point	f=740MHz [4]	-10.5	-8.5		dBm
		f=882MHz [5]	-12.4	-10.4		
		f=943MHz [6]	-10.4	-8.4		
IIP3ib	In-band input 3 <sup>rd</sup> -order intercept point	f=740MHz [4]	3.2	5.2		dBm
		f=882MHz [5]	2.3	4.3		
		f=943MHz [6]	4.3	6.3		
ton	turn-on time	time from V <sub>EN</sub> ON to 90% of the gain		3	4	μs
toff	turn-off time	time from V <sub>EN</sub> OFF to 10% of the gain		1	2	μs
<b>Bypass Mode</b>						
ICC	Supply Current	VEN<0.45V			1	uA
Gp	Power Gain	f=740MHz [4]	-4.5	-3.6	-2	dB
		f=882MHz [5]	-4.8	-3.4	-2	
		f=943MHz [6]	-5.4	-4.5	-2	

Symbol	Parameter	Test Condition	Min	Typ	Max	Units
RLin	Input Return Loss	f=740MHz [4]	18.7	22		dB
		f=882MHz [5]	6.2	11		
		f=943MHz [6]	3.9	6.5		
RLout	Output Return Loss	f=740MHz [4]	7.8	12.2		dB
		f=882MHz [5]	8.5	11.3		
		f=943MHz [6]	5.9	7.6		
IP1dB	In-band input 1dB-compression point	f=740MHz [4]	10	12		dBm
		f=882MHz [5]	10	12		
		f=943MHz [6]	10	12		

[3] High quality-factor 18nH inductor.

[4] E-UTRA operating band 17(734MHz to 746MHz) , input power is -25dBm.

[5] E-UTRA operating band 5(869MHz to 894MHz) , input power is -25dBm.

[6] E-UTRA operating band 8(925MHz to 960MHz) , input power is -25dBm.

[7] PCB losses are subtracted.

TA=+25°C , V<sub>CC</sub>=1.8V, EN=1.8V, frequency=703MHz to 960MHz. Input matched to 50Ω using a 18nH<sup>[3]</sup> inductor in series. (unless otherwise noted).

Symbol	Parameter	Test Condition	Min	Typ	Max	Units
<b>DC Electrical Characteristic</b>						
VCC	Supply Voltage		1.5	-	3.1	V
VEN	Digital Input-Logic High		0.8	-	VCC	V
	Digital Input-Logic Low				0.45	V
<b>Gain Mode</b>						
ICC	Supply Current		8	10.0	12.5	mA
Gp	Power Gain	f=740MHz [4]	18.0	19.0	21.0	dB
		f=882MHz [5]	17.0	19.2	20.0	
		f=943MHz [6]	16.0	17.9	19.0	
RLin	Input Return Loss	f=740MHz [4]	6.3	7.1		dB
		f=882MHz [5]	9.6	11.1		
		f=943MHz [6]	8.4	10.5		
RLout	Output Return Loss	f=740MHz [4]	12.9	14.0		dB
		f=882MHz [5]	6.1	9.1		
		f=943MHz [6]	4.6	6.8		
ISL	Reverse Isolation	f=740MHz [4]	30	37.8		dB
		f=882MHz [5]	30	32.5		
		f=943MHz [6]	30	31.9		
NF	Noise Figure	f=740MHz [4][7]		0.5	0.7	dB
		f=882MHz [5][7]		0.55	0.8	
		f=943MHz [6][7]		0.65	0.9	
IP1dB	In-band input 1dB-compression point	f=740MHz [4]	-13.5	-12.5		dBm
		f=882MHz [5]	-15.4	-14.4		

Symbol	Parameter	Test Condition	Min	Typ	Max	Units
		f=943MHz [6]	-13.4	-11.4		
IIP3ib	In-band input 3 <sup>rd</sup> -order intercept point	f=740MHz [4]	0.2	3.2		dBm
		f=882MHz [5]	0	1.3		
		f=943MHz [6]	1.3	3.3		
ton	turn-on time	time from V <sub>EN</sub> ON to 90% of the gain		3	4	μs
toff	turn-off time	time from V <sub>EN</sub> OFF to 10% of the gain		1	2	μs
<b>Bypass Mode</b>						
ICC	Supply Current	V <sub>EN</sub> <0.45V			1	uA
Gp	Power Gain	f=740MHz [4]	-4.5	-3.6	-2	dB
		f=882MHz [5]	-4.8	-3.4	-2	
		f=943MHz [6]	-5.4	-4.5	-2	
RLin	Input Return Loss	f=740MHz [4]	18.7	22		dB
		f=882MHz [5]	6.2	11		
		f=943MHz [6]	4.5	6.5		
RLout	Output Return Loss	f=740MHz [4]	7.8	12.2		dB
		f=882MHz [5]	8.5	11.3		
		f=943MHz [6]	5.9	7.6		
IP1dB	In-band input 1dB-compression point	f=740MHz [4]	10	12		dBm
		f=882MHz [5]	10	12		
		f=943MHz [6]	10	12		

[3] High quality-factor 18nH inductor.

[4] E-UTRA operating band 17(734MHz to 746MHz) , input power is -25dBm.

[5] E-UTRA operating band 5(869MHz to 894MHz) , input power is -25dBm.

[6] E-UTRA operating band 8(925MHz to 960MHz) , input power is -25dBm.

[7] PCB losses are subtracted.

## APPLICATION INFORMATION

### Choice of components

1. The AW5008L3 requires only one external inductor for input matching. If the device/phone manufacturers implement very good power supply filtering on their boards, the bypass capacitor mentioned in this application circuit may be optional. With the power supply decoupling capacitor, better performance would be received, like a little higher gain, etc. The value is optimized for the key performance, such as higher power gain, lower noise figure, and better return loss. Typical value of inductor is 18nH with high quality factor, and capacitor is 1nF. The typical application circuit can refer to Figure1.

2. The output of AW5008L3 is internally matched to 50 ohm and a DC blocking capacitor is integrated on-chip, thus no external component is required at the output.

3. The AW5008L3 should be placed close to the diversity antenna with the input-matching inductor. Use 50 ohm micro-strip lines to connect RF INPUT and RF OUTPUT. Bypass capacitor need be located close to the device. For long V<sub>CC</sub> lines, it may be necessary to add more decoupling capacitors. Proper grounding of the GND pins is very important.

Following tables show recommended inductor and capacitor values.

**Inductor Selection Table**

Part	Typical(nH)	Q(min)	Frequency(MHz)	MFR	Size
LQW15A	18	25	250	Murata	0402

**Capacitor Selection Table**

Part	Typical(pF)	Voltage(V)	MFR	Size
GRM155	1000	50	Murata	0402

PACKAGE DESCRIPTION

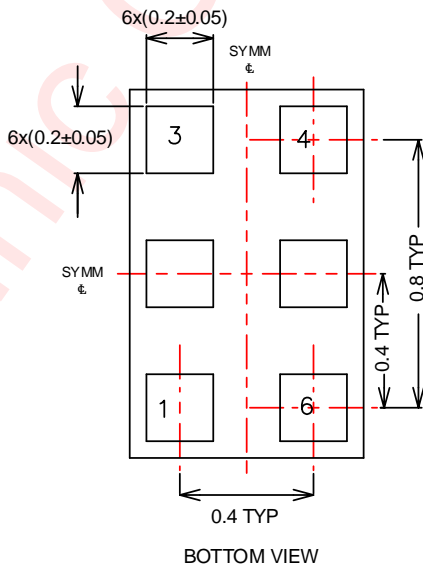
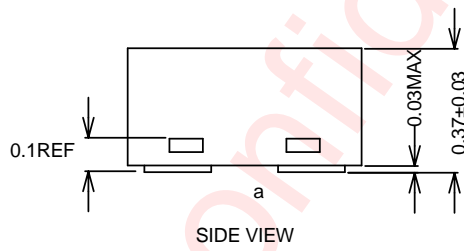
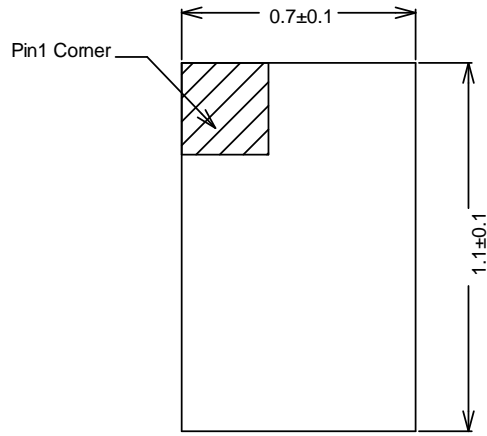

Unit: mm

Figure 4 Package Outline

LAND PATTERN

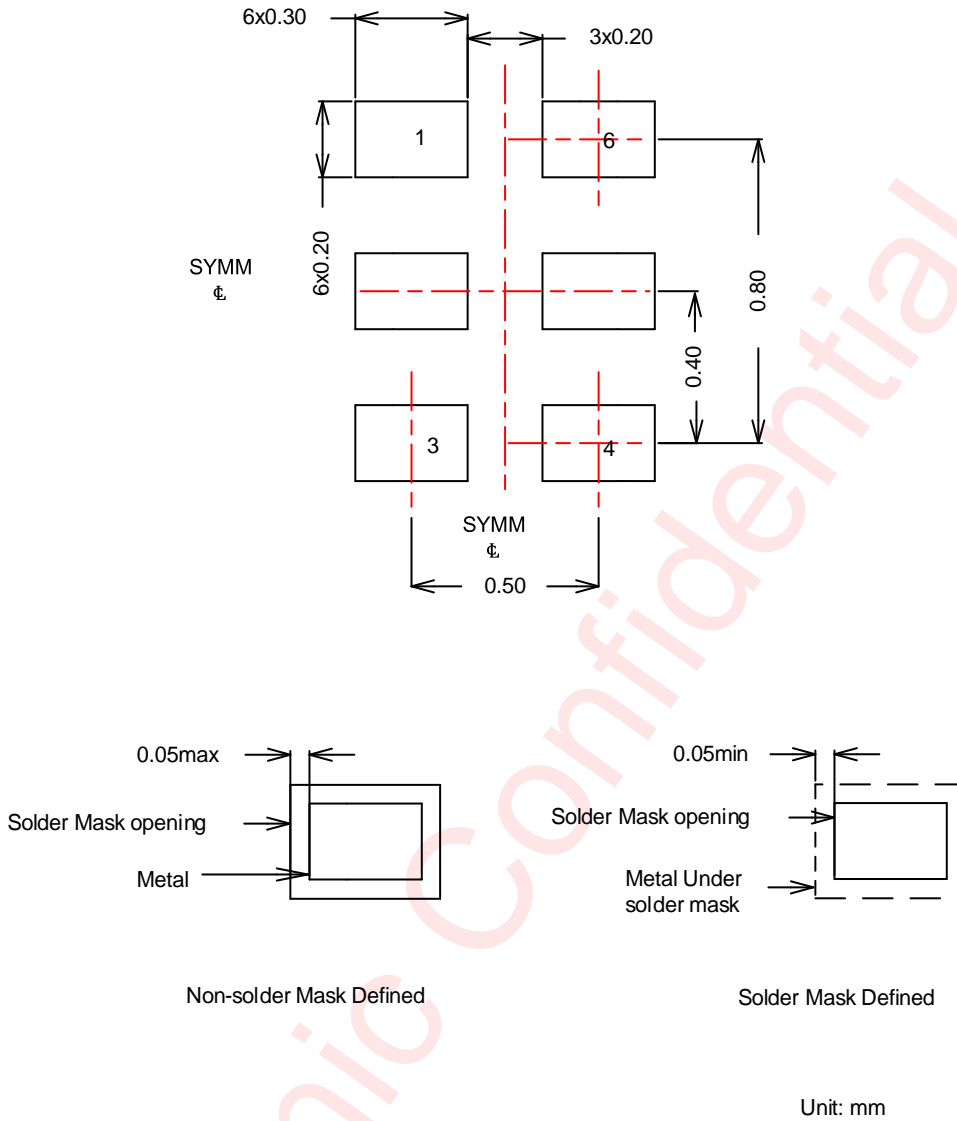
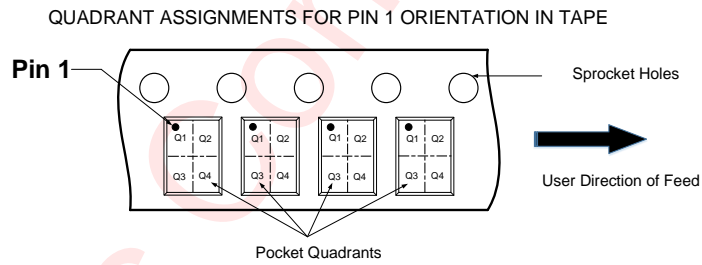
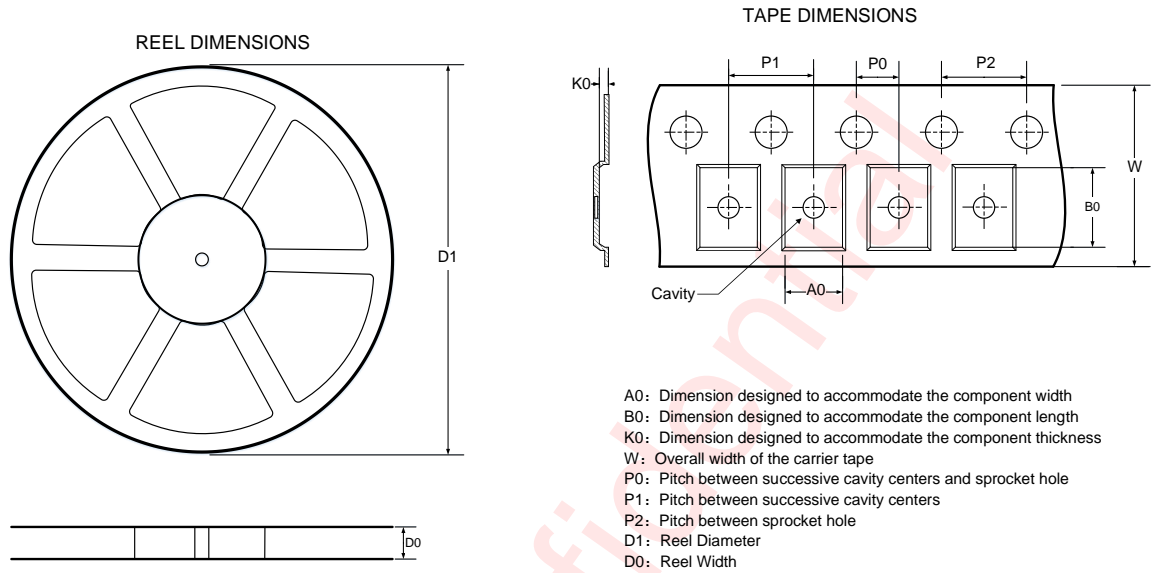

Figure 5 Land Pattern

## TAPE & REEL DESCRIPTION



DIMENSIONS AND PIN1 ORIENTATION

D1 (mm)	D0 (mm)	A0 (mm)	B0 (mm)	K0 (mm)	P0 (mm)	P1 (mm)	P2 (mm)	W (mm)	Pin1 Quadrant
178	8.4	0.8	1.2	0.55	2	2	4	8	Q1

All dimensions are nominal

Figure 6 Tape & Reel Description

## REVISION HISTORY

Version	Date	Change Record
V1.0	Jun 2019	Officially Released
V1.1	Jul 2020	Update electrical characteristics
V1.2	Oct 2020	Update electrical characteristics
V1.3	Nov 2022	Update electrical characteristics

awinic Confidential

## DISCLAIMER

Information in this document is believed to be accurate and reliable. However, Shanghai AWINIC Technology Co., Ltd (AWINIC Technology) does not give any representations or warranties, expressed or implied, as to the accuracy or completeness of such information and shall have no liability for the consequences of use of such information.

AWINIC Technology reserves the right to make changes to information published in this document, including without limitation specifications and product descriptions, at any time and without notice. Customers shall obtain the latest relevant information before placing orders and shall verify that such information is current and complete. This document supersedes and replaces all information supplied prior to the publication hereof.

AWINIC Technology products are not designed, authorized or warranted to be suitable for use in medical, military, aircraft, space or life support equipment, nor in applications where failure or malfunction of an AWINIC Technology product can reasonably be expected to result in personal injury, death or severe property or environmental damage. AWINIC Technology accepts no liability for inclusion and/or use of AWINIC Technology products in such equipment or applications and therefore such inclusion and/or use is at the customer's own risk.

Applications that are described herein for any of these products are for illustrative purposes only. AWINIC Technology makes no representation or warranty that such applications will be suitable for the specified use without further testing or modification.

All products are sold subject to the general terms and conditions of commercial sale supplied at the time of order acknowledgement.

Nothing in this document may be interpreted or construed as an offer to sell products that is open for acceptance or the grant, conveyance or implication of any license under any copyrights, patents or other industrial or intellectual property rights.

Reproduction of AWINIC information in AWINIC data books or data sheets is permissible only if reproduction is without alteration and is accompanied by all associated warranties, conditions, limitations, and notices. AWINIC is not responsible or liable for such altered documentation. Information of third parties may be subject to additional restrictions.

Resale of AWINIC components or services with statements different from or beyond the parameters stated by AWINIC for that component or service voids all express and any implied warranties for the associated AWINIC component or service and is an unfair and deceptive business practice. AWINIC is not responsible or liable for any such statements.