

LC75897PWS-T

CMOS LSI

1/3 and 1/4-Duty

General-Purpose LCD Driver



ON Semiconductor®

www.onsemi.com

Overview

The LC75897PWS-T is 1/3 duty and 1/4 duty general-purpose LCD display driver that can be used for frequency display in electronic tuners under the control of a microcontroller. The LC75897PWS-T can drive an LCD with up to 512 segments directly. The LC75897PWS-T can also control up to 8 general-purpose output ports. The LC75897PWS-T has a built-in of up to three PWM output port channels, which enables to adjust the brightness of the RGB LED backlight.

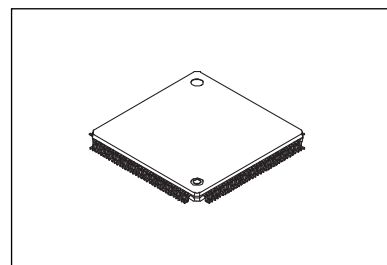

SPQFP144 20x20 / SQFP144

Features

- Switching between 1/3 duty and 1/4 duty drive techniques under serial data control.
- Switching between 1/2 bias and 1/3 bias drive techniques under serial data control.
- Up to 387 segments for 1/3 duty drive and 512 segments for 1/4 duty drive can be displayed.
- Switching between the segment, general-purpose, PWM, and clock output ports can be controlled using serial data (up to 8 general-purpose output ports, up to 3-channel PWM output ports, and one clock output port).
- Serial data input supports CCB format communication with the system controller.
- Serial data control of the power-saving mode based backup function and all the segments forced off function.
- Serial data control of the frame frequency for common and segment output waveforms.
- Serial data control of switching between the RC oscillator operating mode and external clock operating mode.
- High generality, since display data is displayed directly without decoder intervention.
- Built-in display contrast adjustment circuit
- Independent V_{LCD} for the LCD driver block
- The INH pin can force the display to the off state.
- RC oscillator circuit

• CCB is ON Semiconductor®'s original format. All addresses are managed by ON Semiconductor® for this format.

• CCB is a registered trademark of Semiconductor Components Industries, LLC.

ORDERING INFORMATION

See detailed ordering and shipping information on page 34 of this data sheet.

LC75897PWS-T

Specifications

Absolute Maximum Ratings at $T_a = 25^\circ\text{C}$, $V_{SS} = 0\text{V}$

Parameter	Symbol	Conditions	Ratings	Unit
Maximum supply voltage	$V_{DD\text{ max}}$	V_{DD}	-0.3 to +7.0	V
	$V_{LCD\text{ max}}$	V_{LCD}	-0.3 to +7.0	
Input voltage	V_{IN1}	CE, CL, DI, \overline{INH}	-0.3 to +7.0	V
	V_{IN2}	OSC	-0.3 to $V_{DD}+0.3$	
	V_{IN3}	V_{LCD1} , V_{LCD2}	-0.3 to $V_{LCD}+0.3$	
Output voltage	V_{OUT1}	OSC	-0.3 to $V_{DD}+0.3$	V
	V_{OUT2}	V_{LCD0} , S1 to S129, COM1 to COM4, P1 to P8	-0.3 to $V_{LCD}+0.3$	
Output current	I_{OUT1}	S1 to S129	300	μA
	I_{OUT2}	COM1 to COM4	3	mA
	I_{OUT3}	P1 to P8	5	
Allowable power dissipation	$P_d\text{ max}$	$T_a = 105^\circ\text{C}$	100	mW
Operating temperature	T_{opr}		-40 to +105	$^\circ\text{C}$
Storage temperature	T_{stg}		-55 to +125	$^\circ\text{C}$

Stresses exceeding those listed in the Maximum Ratings table may damage the device. If any of these limits are exceeded, device functionality should not be assumed, damage may occur and reliability may be affected.

Allowable Operating Ranges at $T_a = -40$ to $+105^\circ\text{C}$, $V_{SS} = 0\text{V}$

Parameter	Symbol	Conditions	Ratings			unit
			min	typ	max	
Supply voltage	V_{DD}	V_{DD}	2.7		6.0	V
	V_{LCD}	V_{LCD} , $V_{LCD0} = 0.70V_{LCD}$ to $0.95V_{LCD}$	4.0		6.0	
		V_{LCD} , $V_{LCD0} = V_{LCD}$	2.7		6.0	
Output voltage	V_{LCD0}	V_{LCD0}	2.7		V_{LCD}	V
Input voltage	V_{LCD1}	V_{LCD1}		$2/3V_{LCD0}$	V_{LCD0}	V
	V_{LCD2}	V_{LCD2}		$1/3V_{LCD0}$	V_{LCD0}	
Input high-level voltage	V_{IH1}	CE, CL, DI, \overline{INH}	$0.8V_{DD}$		6.0	V
	V_{IH2}	OSC external clock operating mode	$0.7V_{DD}$		V_{DD}	
Input low-level voltage	V_{IL1}	CE, CL, DI, \overline{INH}	0		$0.2V_{DD}$	V
	V_{IL2}	OSC external clock operating mode	0		$0.3V_{DD}$	
Recommended external resistor for RC oscillation	R_{OSC}	OSC RC oscillator operating mode		10		k Ω
Recommended external capacitor for RC oscillation	C_{OSC}	OSC RC oscillator operating mode		470		pF
Guaranteed range of RC oscillation	f_{OSC}	OSC RC oscillator operating mode	150	300	600	kHz
External clock operating frequency	f_{CK}	OSC external clock operating mode [Figure 4]	150	300	600	kHz
External clock duty cycle	D_{CK}	OSC external clock operating mode [Figure 4]	30	50	70	%
Data setup time	t_{ds}	CL, DI [Figure 2],[Figure 3]	160			ns
Data hold time	t_{dh}	CL, DI [Figure 2],[Figure 3]	160			ns
CE wait time	t_{cp}	CE, CL [Figure 2],[Figure 3]	160			ns
CE setup time	t_{cs}	CE, CL [Figure 2],[Figure 3]	160			ns
CE hold time	t_{ch}	CE, CL [Figure 2],[Figure 3]	160			ns
High-level clock pulse width	$t_{\phi H}$	CL [Figure 2],[Figure 3]	160			ns
Low-level clock pulse width	$t_{\phi L}$	CL [Figure 2],[Figure 3]	160			ns
Rise time	t_r	CE, CL, DI [Figure 2],[Figure 3]		160		ns
Fall time	t_f	CE, CL, DI [Figure 2],[Figure 3]		160		ns
\overline{INH} switching time	t_c	\overline{INH} , CE [Figure 5],[Figure 6]	10			μs

Functional operation above the stresses listed in the Recommended Operating Ranges is not implied. Extended exposure to stresses beyond the Recommended Operating Ranges limits may affect device reliability.

LC75897PWS-T

Electrical Characteristics for the Allowable Operating Ranges

Parameter	Symbol	Pin	Conditions	Ratings			unit
				min	typ	max	
Hysteresis	V_H	CE, CL, DI, INH			0.1 V_{DD}		V
Input high-level current	I_{IH1}	CE, CL, DI, INH	$V_I = 6.0V$			5.0	μA
	I_{IH2}	OSC	$V_I = V_{DD}$ External clock operating mode			5.0	
Input low-level current	I_{IL1}	CE, CL, DI, INH	$V_I = 0V$	-5.0			μA
	I_{IL2}	OSC	$V_I = 0V$ External clock operating mode	-5.0			
Output high-level voltage	V_{OH1}	S1 to S129	$I_O = -20\mu A$	$V_{LCD0} - 0.9$			V
	V_{OH2}	COM1 to COM4	$I_O = -100\mu A$	$V_{LCD0} - 0.9$			
	V_{OH3}	P1 to P8	$I_O = -1mA$	$V_{LCD} - 0.9$			
Output low-level voltage	V_{OL1}	S1 to S129	$I_O = 20\mu A$			0.9	V
	V_{OL2}	COM1 to COM4	$I_O = 100\mu A$			0.9	
	V_{OL3}	P1 to to P8	$I_O = 1mA$			0.9	
Output middle-level voltage *1	V_{MID1}	COM1 to COM4	1/2 bias, $I_O = \pm 100\mu A$	$1/2V_{LCD0} - 0.9$		$1/2V_{LCD0} + 0.9$	V
	V_{MID2}	S1 to S129	1/3 bias, $I_O = \pm 20\mu A$	$2/3V_{LCD0} - 0.9$		$2/3V_{LCD0} + 0.9$	
	V_{MID3}	S1 to S129	1/3 bias, $I_O = \pm 20\mu A$	$1/3V_{LCD0} - 0.9$		$1/3V_{LCD0} + 0.9$	
	V_{MID4}	COM1 to COM4	1/3 bias, $I_O = \pm 100\mu A$	$2/3V_{LCD0} - 0.9$		$2/3V_{LCD0} + 0.9$	
	V_{MID5}	COM1 to COM4	1/3 bias, $I_O = \pm 100\mu A$	$1/3V_{LCD0} - 0.9$		$1/3V_{LCD0} + 0.9$	
Oscillator frequency	f_{OSC}	OSC	RC oscillator operating mode $R_{OSC} = 10k\Omega$ $C_{OSC} = 470pF$	210	300	390	kHz
Current drain	I_{DD1}	V_{DD}	Power-saving mode			15	μA
	I_{DD2}	V_{DD}	$V_{DD} = 6.0V$, output open, $f_{OSC} = 300kHz$		700	1400	
	I_{LCD1}	V_{LCD}	Power-saving mode			20	
	I_{LCD2}	V_{LCD}	$V_{LCD} = 6.0V$, output open, 1/2 bias, $f_{OSC} = 300kHz$, $V_{LCD0} = 0.70V_{LCD}$ to $0.95V_{LCD}$		600	1200	
	I_{LCD3}	V_{LCD}	$V_{LCD} = 6.0V$, output open, 1/2 bias, $f_{OSC} = 300kHz$, $V_{LCD0} = V_{LCD}$		500	1000	
	I_{LCD4}	V_{LCD}	$V_{LCD} = 6.0V$, output open, 1/3 bias, $f_{OSC} = 300kHz$, $V_{LCD0} = 0.70V_{LCD}$ to $0.95V_{LCD}$		450	900	
	I_{LCD5}	V_{LCD}	$V_{LCD} = 6.0V$, output open, 1/3 bias, $f_{OSC} = 300kHz$, $V_{LCD0} = V_{LCD}$		350	700	

Note: *1 Excluding the bias voltage generation divider resistors built in the V_{LCD0} , V_{LCD1} , V_{LCD2} , and V_{SS} .
(See Figure 1.)

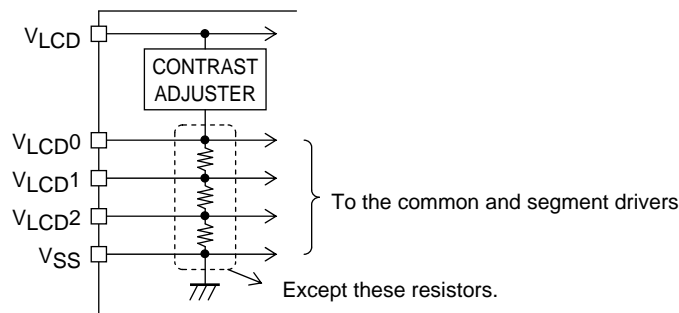

[Figure 1]

Product parametric performance is indicated in the Electrical Characteristics for the listed test conditions, unless otherwise noted. Product performance may not be indicated by the Electrical Characteristics if operated under different conditions.

LC75897PWS-T

1. When CL is stopped at the low level

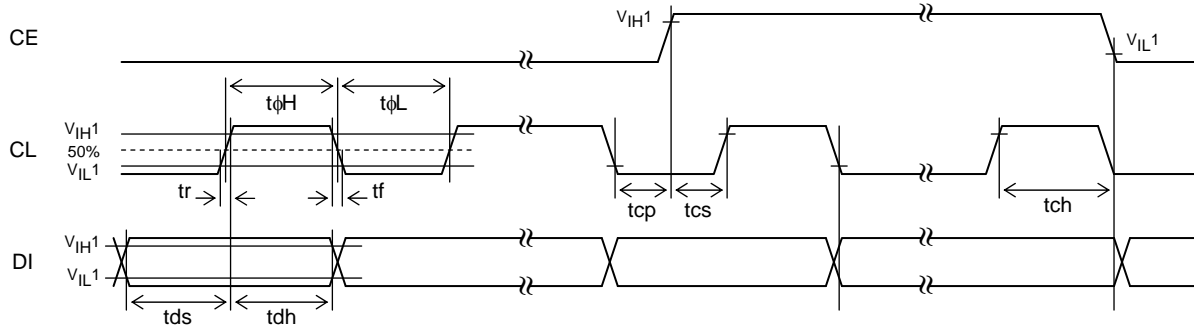

Figure 2

2. When CL is stopped at the high level

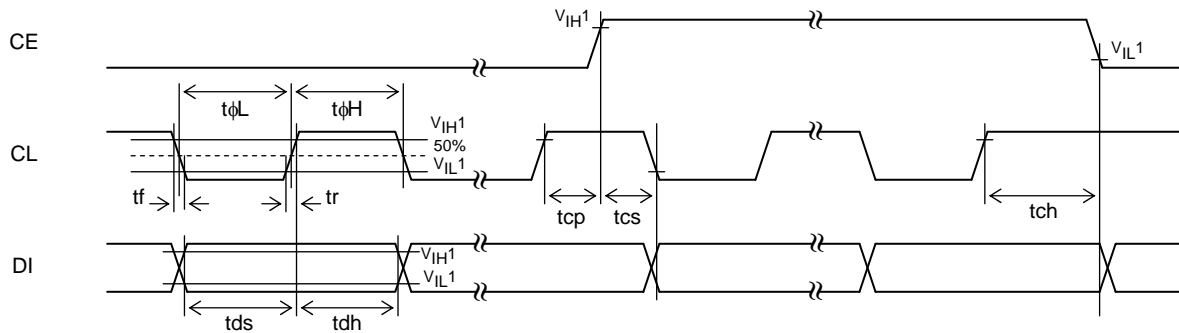

Figure 3

3. OSC pin clock timing in external clock operating mode

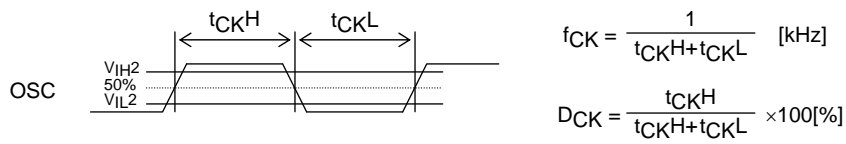
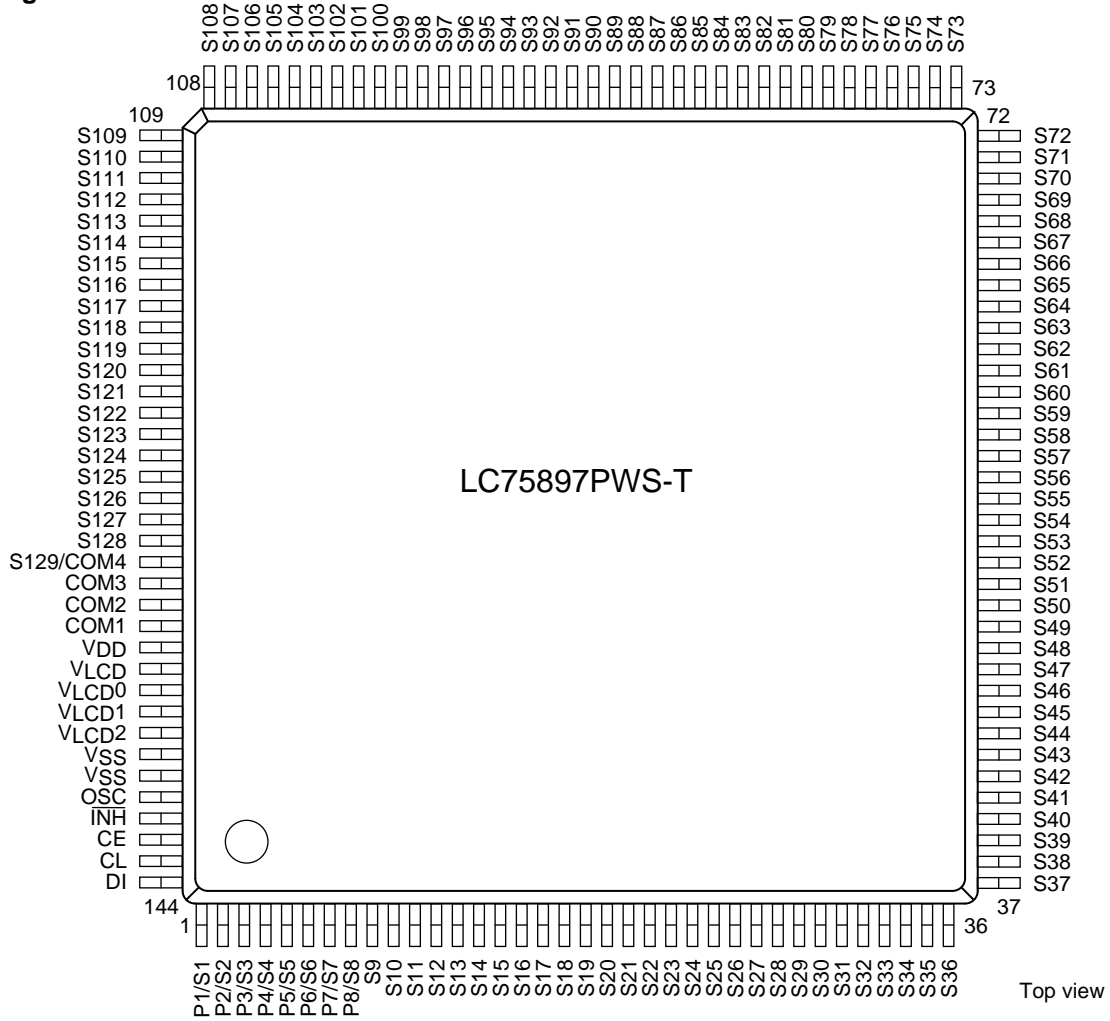

Figure 4

LC75897PWS-T

Pin Assignment



Block Diagram

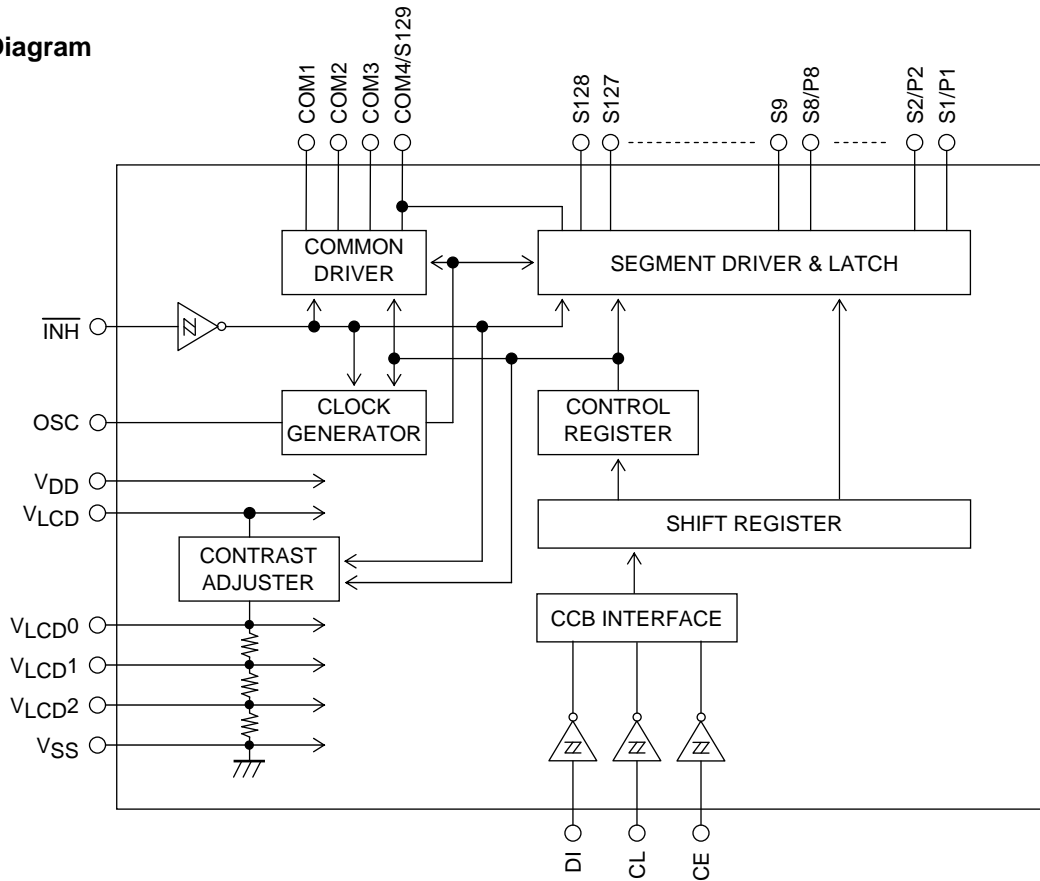

LC75897PWS-T

Pin Functions

Symbol	Pin No.	Function	Active	I/O	Handling when unused
S1/P1 to S8/P8 S9 to S128	1 to 8 9 to 128	Segment outputs for displaying the display data transferred by serial data input. Also, by the control data, S1/P1 to S3/P3 can be used as a general-purpose output port or PWM output port, while S4/P4 can be used as a general-purpose output port or clock output port and S5/P5 to S8/P8 can be used as a general-purpose output port.	-	O	OPEN
COM1 to COM3 COM4/S129	132 to 130 129	Common driver outputs. The frame frequency is fo [Hz]. The COM4/S129 pin can be used as a segment output in 1/3 duty.	-	O	OPEN
OSC	140	Oscillator connection. An oscillator circuit is formed by connecting an external resistor and capacitor to this pin. This pin can also be used as the external clock input pin as controlled by control data.	-	I/O	V_{DD}
CE CL DI	142 143 144	Serial data transfer inputs. These pins are connected to the control microprocessor. CE: Chip enable CL: Synchronization clock DI: Transfer data	H  -	I I I	GND
$\overline{\text{INH}}$	141	Display off control input • $\overline{\text{INH}}$ = low (V_{SS}) ...Off S1/P1 to S8/P8 = low (V_{SS}) (These pins are forcibly set to the segment output port function and fixed at the V_{SS} level.) S9 to S128 = low (V_{SS}) COM1 to COM3 = low (V_{SS}) COM4/S129 = low (V_{SS}) OSC = "Z" (high impedance) RC oscillation stopped External clock input inhibited Display contrast adjustment circuit stopped • $\overline{\text{INH}}$ = high (V_{DD}) ...On RC oscillation enabled (RC oscillator operating mode) Enables external clock input (external clock operating mode). Display contrast adjustment circuit enabled Note that serial data transfers can be performed when the display is forced off by this pin.	L	I	GND
V_{LCD0}	135	LCD drive 3/3 bias voltage (high level) supply. This level can be modified using the display contrast adjustment circuit. However, note that V_{LCD0} must be greater than or equal to 2.7V. Also, since this IC provides the built-in display contrast adjustment circuit, applications must not attempt to provide this level from external circuits.	-	O	OPEN
V_{LCD1}	136	LCD drive 2/3 bias voltage (middle level) supply. It is possible to supply the $2/3V_{LCD0}$ voltage to this pin externally. This pin must be shorted to V_{LCD2} if 1/2 bias is used.	-	I	OPEN
V_{LCD2}	137	LCD drive 1/3 bias voltage (middle level) supply. It is possible to supply the $1/3V_{LCD0}$ voltage to this pin externally. This pin must be shorted to V_{LCD1} if 1/2 bias is used.	-	I	OPEN
V_{DD}	133	Logic block power supply. Provide a voltage in the range 2.7 to 6.0V.	-	-	-
V_{LCD}	134	LCD driver block power supply. When V_{LCD0} is between $0.70V_{LCD}$ and $0.95V_{LCD}$, supply a voltage in the range 4.0 to 6.0V. When V_{LCD0} and V_{LCD} will be equal, supply a voltage in the range 2.7 to 6.0V.	-	-	-
V_{SS}	138,139	Ground pin. Connect to ground.	-	-	-

LC75897PWS-T

Serial Data Transfer Formats

(1) 1/3 duty

1. When CL is stopped at the low level

- When the display data is transferred

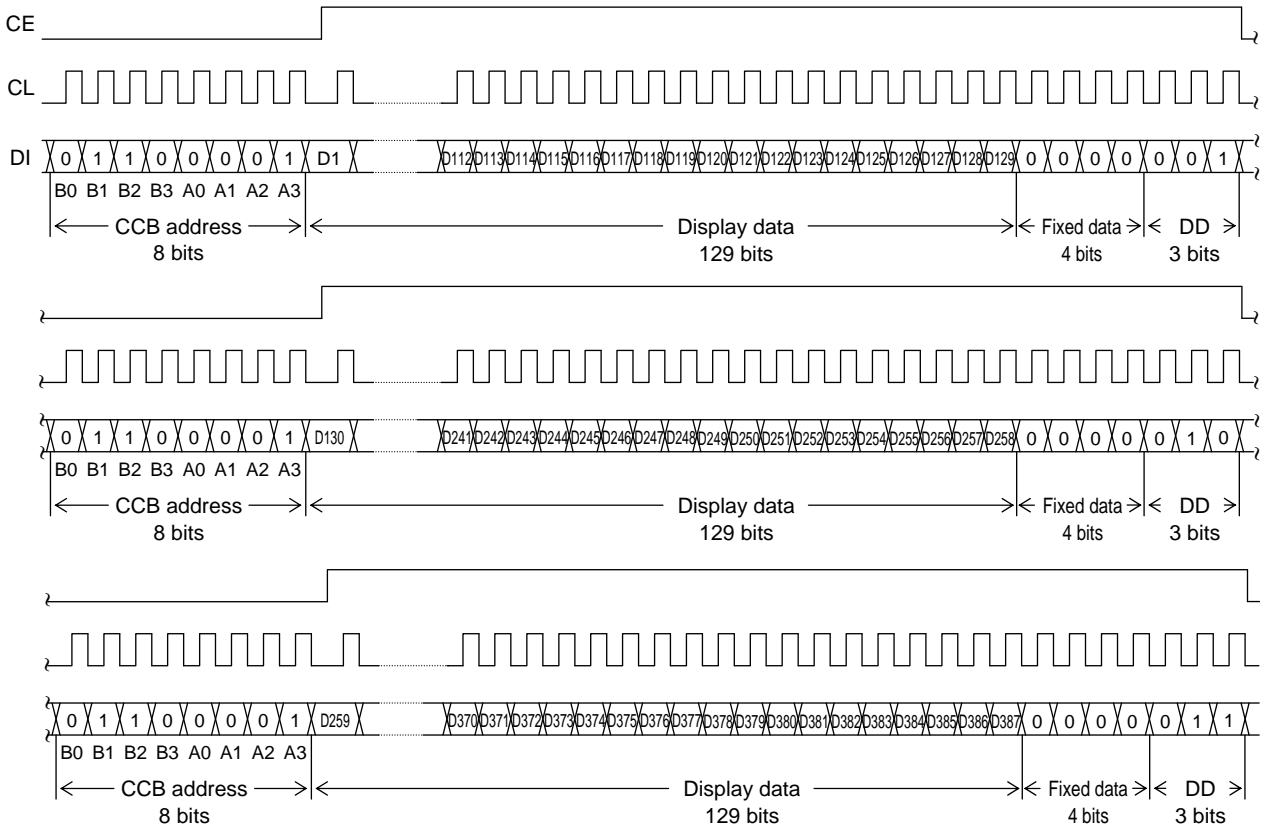

- When the control data is transferred

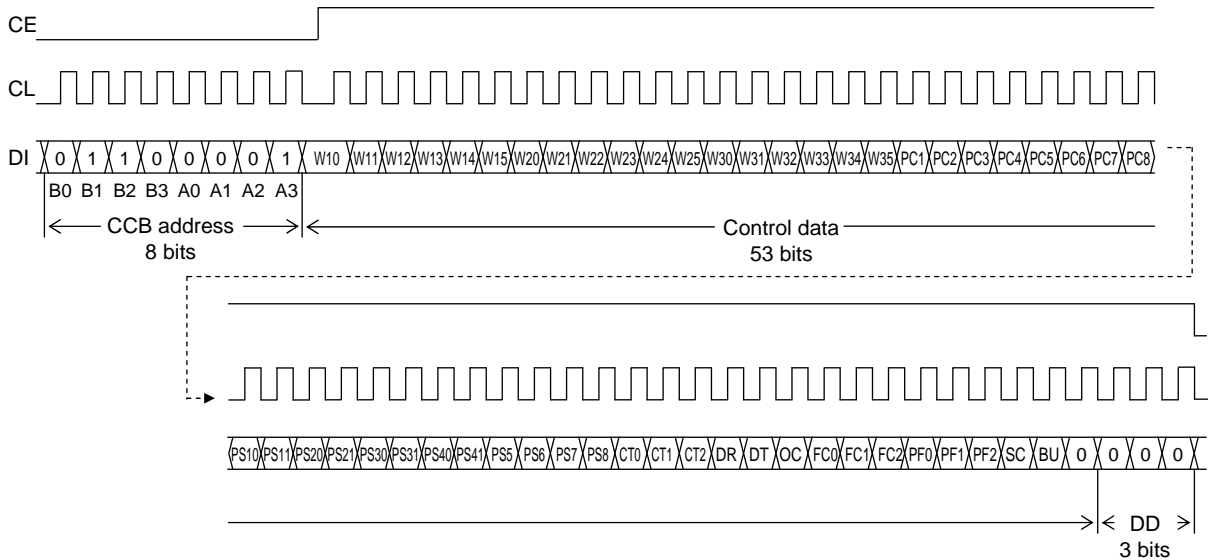

Note: DD is the direction data.

LC75897PWS-T

2. When CL is stopped at the high level
- When the display data is transferred

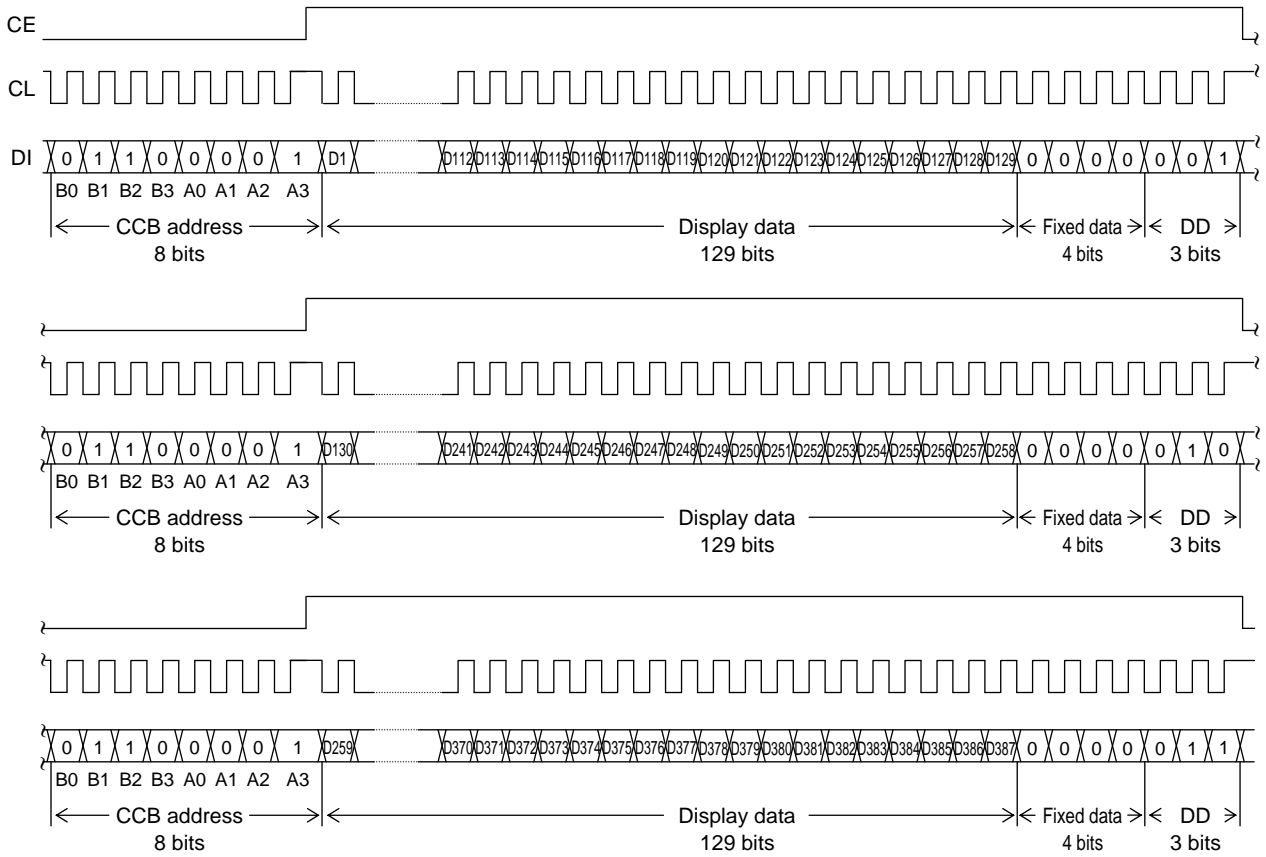

LC75897PWS-T

- When the control data is transferred

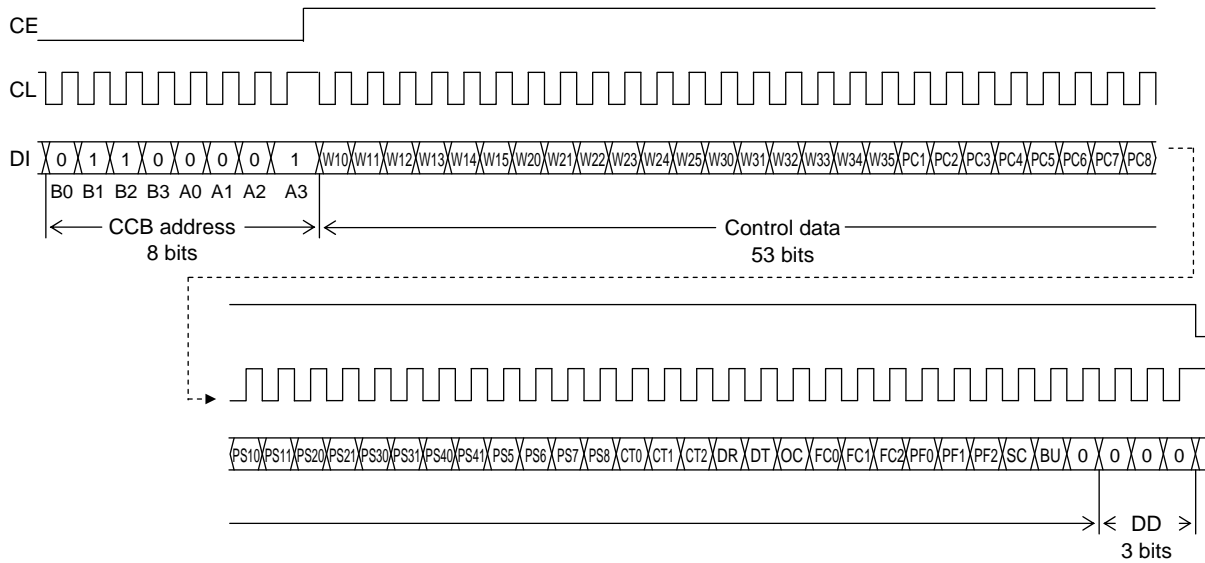

Note: DD is the direction data.

- CCB address "86H"
- D1 to D387 Display data
- W10 to W15, W20 to W25, W30 to W35
..... PWM data at PWM output ports
- PC1 to PC8 General-purpose output port state setting control data
- PS10, PS11, PS20, PS21, PS30, PS31, PS40, PS41, PS5 to PS8
..... Segment output port/general-purpose output port/PWM output port/clock output port switching control data
- CT0 to CT2 Display contrast setting control data
- DR 1/2 bias drive or 1/3 bias drive switching control data
- DT 1/3 duty drive or 1/4 duty drive switching control data
- OC RC oscillator operating mode/external clock operating mode switching control data
- FC0 to FC2 Common and segment output waveforms frame frequency setting control data
- PF0 to PF2 PWM output waveforms frame frequency setting control data
- SC Segments on/off control data
- BU Normal mode/power-saving mode control data

LC75897PWS-T

(2) 1/4 duty

1. When CL is stopped at the low level

- When the display data is transferred

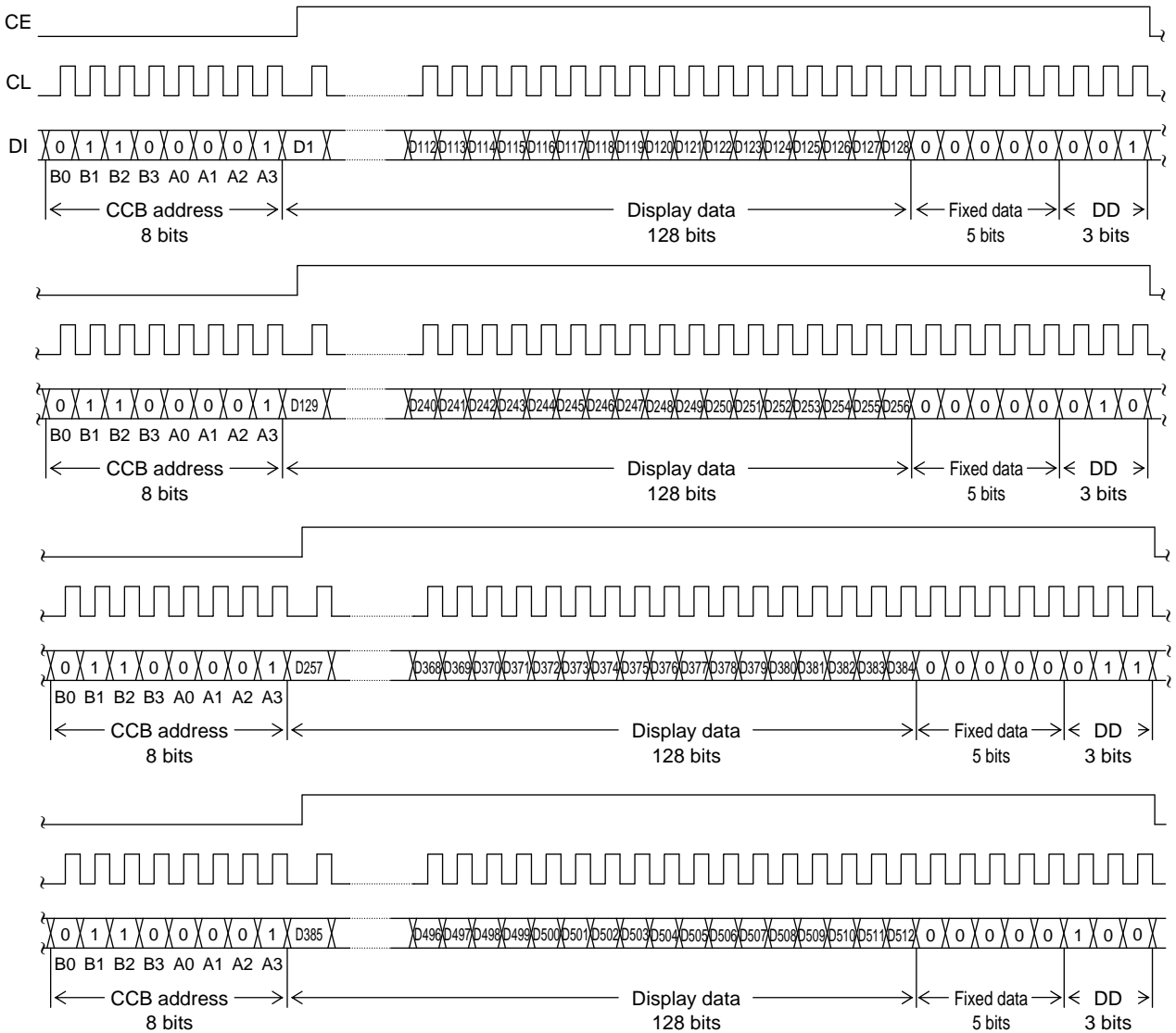

- When the control data is transferred

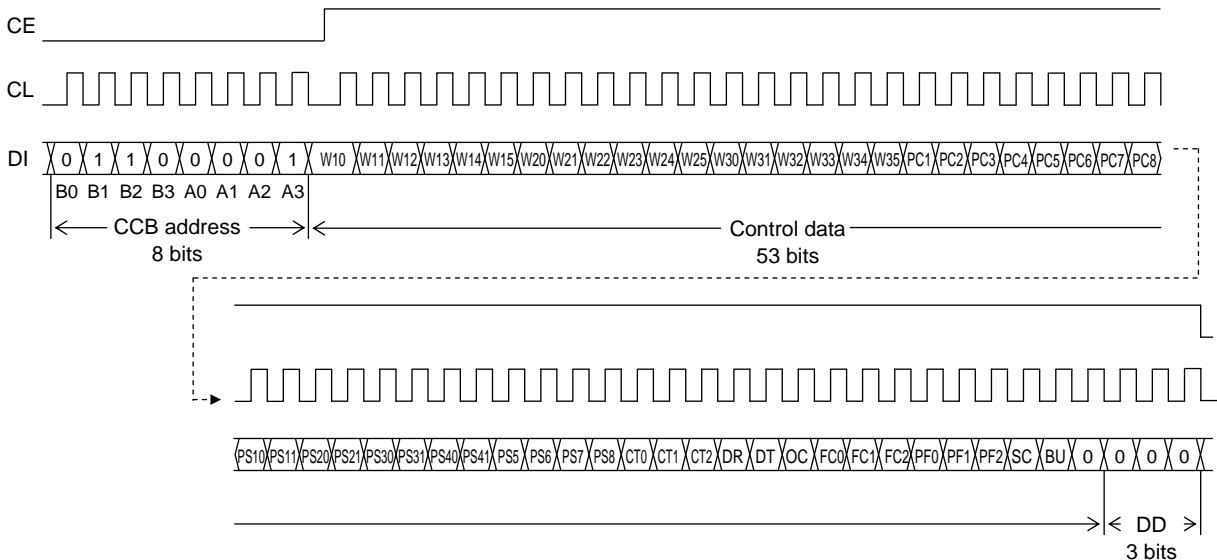

Note: DD is the direction data.

LC75897PWS-T

2. When CL is stopped at the high level
- When the display data is transferred

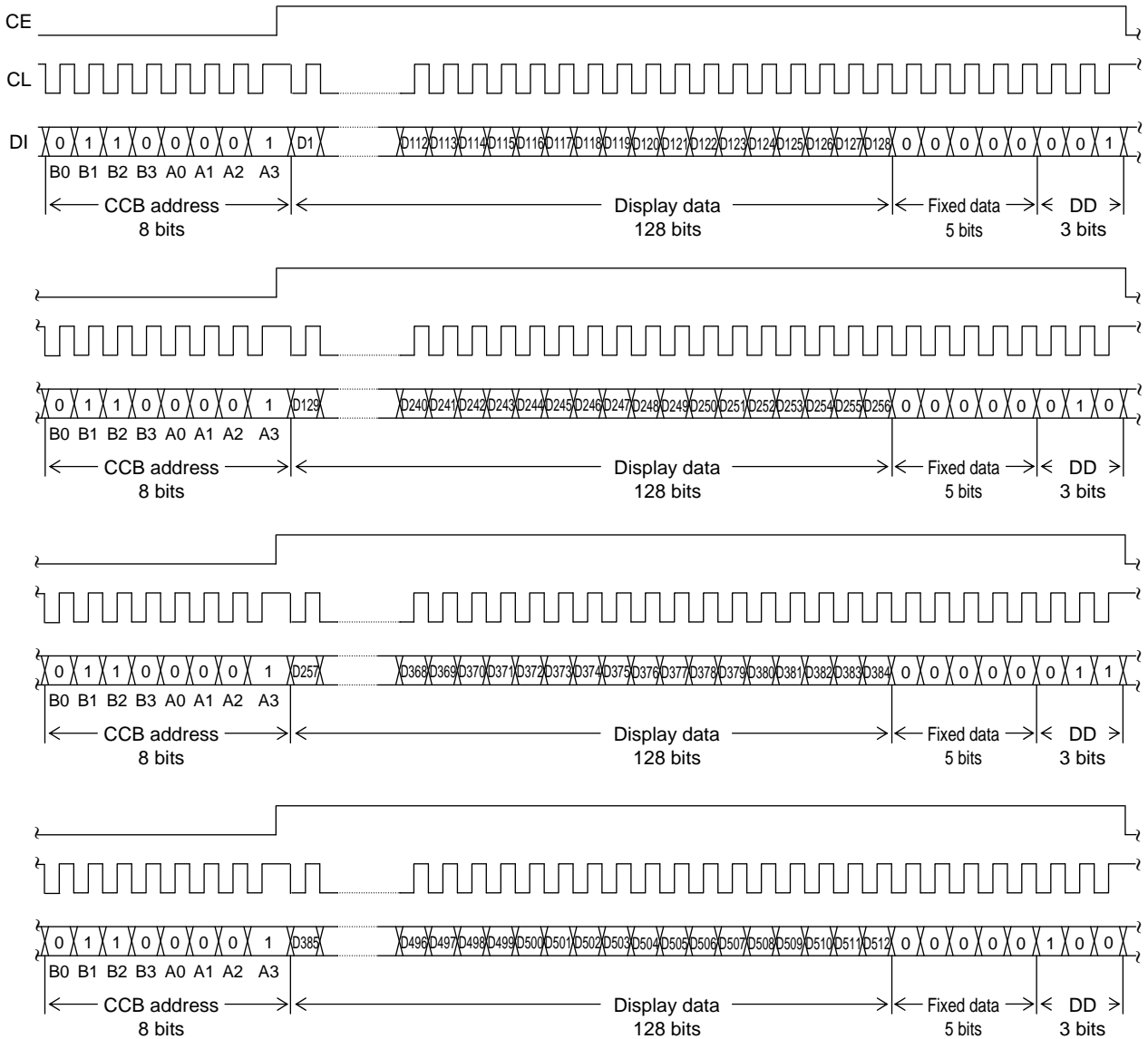

LC75897PWS-T

- When the control data is transferred

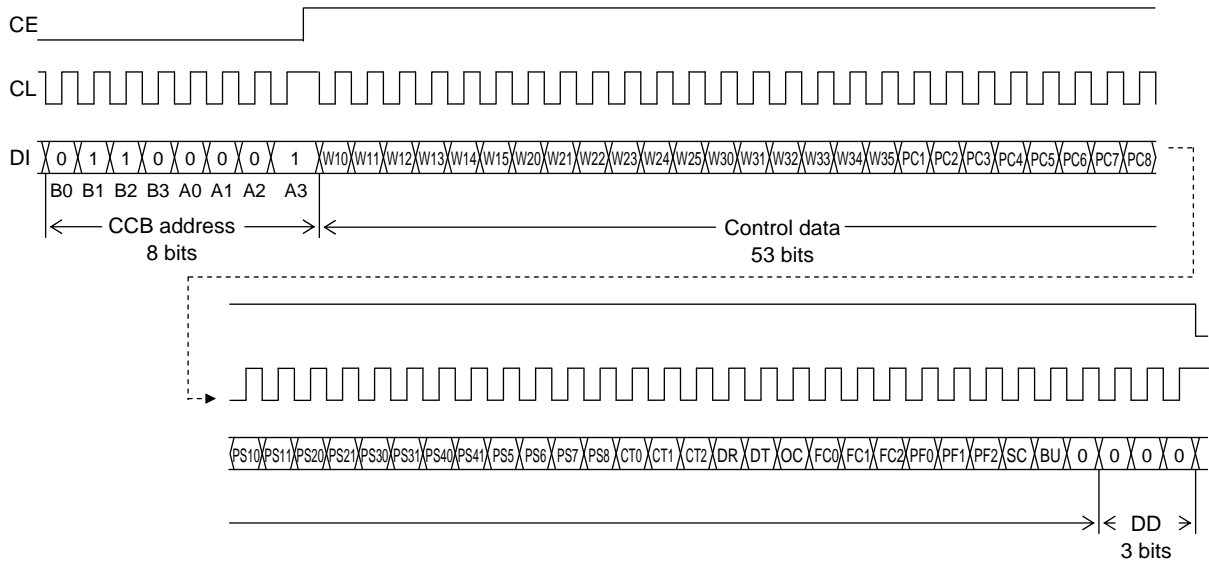

Note: DD is the direction data.

- CCB address "86H"
- D1 to D512 Display data
- W10 to W15, W20 to W25, W30 to W35
..... PWM data at PWM output ports
- PC1 to PC8 General-purpose output port state setting control data
- PS10, PS11, PS20, PS21, PS30, PS31, PS40, PS41, PS5 to PS8
..... Segment output port/general-purpose output port/PWM output port/clock output port switching control data
- CT0 to CT2 Display contrast setting control data
- DR 1/2 bias drive or 1/3 bias drive switching control data
- DT 1/3 duty drive or 1/4 duty drive switching control data
- OC RC oscillator operating mode/external clock operating mode switching control data
- FC0 to FC2 Common and segment output waveforms frame frequency setting control data
- PF0 to PF2 PWM output waveforms frame frequency setting control data
- SC Segments on/off control data
- BU Normal mode/power-saving mode control data

LC75897PWS-T

Control Data Functions

(1) W10 to W15, W20 to W25, W30 to W35: PWM data at PWM output ports

This control data determines the pulse width of the PWM at PWM output ports P1/S1 to P3/S3.

Wn0	Wn1	Wn2	Wn3	Wn4	Wn5	Pulse width of PWM output port Pn	Wn0	Wn1	Wn2	Wn3	Wn4	Wn5	Pulse width of PWM output port Pn
0	0	0	0	0	0	(1/64)×Tp	0	0	0	0	0	1	(33/64)×Tp
1	0	0	0	0	0	(2/64)×Tp	1	0	0	0	0	1	(34/64)×Tp
0	1	0	0	0	0	(3/64)×Tp	0	1	0	0	0	1	(35/64)×Tp
1	1	0	0	0	0	(4/64)×Tp	1	1	0	0	0	1	(36/64)×Tp
0	0	1	0	0	0	(5/64)×Tp	0	0	1	0	0	1	(37/64)×Tp
1	0	1	0	0	0	(6/64)×Tp	1	0	1	0	0	1	(38/64)×Tp
0	1	1	0	0	0	(7/64)×Tp	0	1	1	0	0	1	(39/64)×Tp
1	1	1	0	0	0	(8/64)×Tp	1	1	1	0	0	1	(40/64)×Tp
0	0	0	1	0	0	(9/64)×Tp	0	0	0	1	0	1	(41/64)×Tp
1	0	0	1	0	0	(10/64)×Tp	1	0	0	1	0	1	(42/64)×Tp
0	1	0	1	0	0	(11/64)×Tp	0	1	0	1	0	1	(43/64)×Tp
1	1	0	1	0	0	(12/64)×Tp	1	1	0	1	0	1	(44/64)×Tp
0	0	1	1	0	0	(13/64)×Tp	0	0	1	1	0	1	(45/64)×Tp
1	0	1	1	0	0	(14/64)×Tp	1	0	1	1	0	1	(46/64)×Tp
0	1	1	1	0	0	(15/64)×Tp	0	1	1	1	0	1	(47/64)×Tp
1	1	1	1	0	0	(16/64)×Tp	1	1	1	1	0	1	(48/64)×Tp
0	0	0	0	1	0	(17/64)×Tp	0	0	0	0	1	1	(49/64)×Tp
1	0	0	0	1	0	(18/64)×Tp	1	0	0	0	1	1	(50/64)×Tp
0	1	0	0	1	0	(19/64)×Tp	0	1	0	0	1	1	(51/64)×Tp
1	1	0	0	1	0	(20/64)×Tp	1	1	0	0	1	1	(52/64)×Tp
0	0	1	0	1	0	(21/64)×Tp	0	0	1	0	1	1	(53/64)×Tp
1	0	1	0	1	0	(22/64)×Tp	1	0	1	0	1	1	(54/64)×Tp
0	1	1	0	1	0	(23/64)×Tp	0	1	1	0	1	1	(55/64)×Tp
1	1	1	0	1	0	(24/64)×Tp	1	1	1	0	1	1	(56/64)×Tp
0	0	0	1	1	0	(25/64)×Tp	0	0	0	1	1	1	(57/64)×Tp
1	0	0	1	1	0	(26/64)×Tp	1	0	0	1	1	1	(58/64)×Tp
0	1	0	1	1	0	(27/64)×Tp	0	1	0	1	1	1	(59/64)×Tp
1	1	0	1	1	0	(28/64)×Tp	1	1	0	1	1	1	(60/64)×Tp
0	0	1	1	1	0	(29/64)×Tp	0	0	1	1	1	1	(61/64)×Tp
1	0	1	1	1	0	(30/64)×Tp	1	0	1	1	1	1	(62/64)×Tp
0	1	1	1	1	0	(31/64)×Tp	0	1	1	1	1	1	(63/64)×Tp
1	1	1	1	1	0	(32/64)×Tp	1	1	1	1	1	1	(64/64)×Tp

Note: Wn0 to Wn5 (n = 1 to 3): PWM data at output pins S1/P1 to S3/P3

$$T_p = \frac{1}{f_p}$$

(2) PC1 to PC8: General-purpose output port state setting control data

This control data is used to set the high/low state of general-purpose output ports P1 to P8.

Output pins	P1	P2	P3	P4	P5	P6	P7	P8
Control data	PC1	PC2	PC3	PC4	PC5	PC6	PC7	PC8

Note: PCn = 1: The output pin Pn is set high (V_{LCD}) (n = 1 to 8).

PCn = 0: The output pin Pn is set low (V_{SS}) (n = 1 to 8).

For example, if output pins S4/P4 and S5/P5 are selected as general-purpose output ports, setting PC4 to 1 and PC5 to 0 causes the output pin P4 to be set high (V_{LCD}) and P5 to be set low (V_{SS}).

LC75897PWS-T

(3) PS10, PS11, PS20, PS21, PS30, PS31, PS40, PS41, PS5 to PS8: Segment output port/general-purpose output port/PWM output port/clock output port switching control data.

This control data is used to set the state of output pins S1/P1 to S8/P8.

PS10 and PS11: Output pin (S1/P1) state settings

PS10	PS11	Output pin (S1/P1) state
0	0	Segment output port (S1)
1	0	General-purpose output port (P1)
0	1	PWM output port (P1)

PS20 and PS21: Output pin (S2/P2) state settings

PS20	PS21	Output pin (S2/P2) state
0	0	Segment output port (S2)
1	0	General-purpose output port (P2)
0	1	PWM output port (P2)

PS30 and PS31: Output pin (S3/P3) state settings

PS30	PS31	Output pin (S3/P3) state
0	0	Segment output port (S3)
1	0	General-purpose output port (P3)
0	1	PWM output port (P3)

PS40 and PS41: Output pin (S4/P4) state settings

PS40	PS41	Output pin (S4/P4) state
0	0	Segment output port (S4)
1	0	General-purpose output port (P4)
0	1	Clock output port (P4) (clock frequency $f_{osc}/2$, $f_{CK}/2$)
1	1	Clock output port (P4) (clock frequency $f_{osc}/8$, $f_{CK}/8$)

PS5: Output pin (S5/P5) state settings

PS5	Output pin (S5/P5) state
0	Segment output port (S5)
1	General-purpose output port (P5)

PS6: Output pin (S6/P6) state settings

PS6	Output pin (S6/P6) state
0	Segment output port (S6)
1	General-purpose output port (P6)

PS7: Output pin (S7/P7) state settings

PS7	Output pin (S7/P7) state
0	Segment output port (S7)
1	General-purpose output port (P7)

PS8: Output pin (S8/P8) state settings

PS8	Output pin (S8/P8) state
0	Segment output port (S8)
1	General-purpose output port (P8)

For example, if PS10 and PS11 are set to 0 and 1 respectively, PS20 and PS21 to 0 and 1 respectively, PS30 and PS31 to 0 and 1 respectively, PS40 and PS41 to 1 and 0 respectively, PS5 to 1, PS6 to 1, PS7 to 0, and PS8 to 0, the output pins S1/P1 to S3/P3 are selected as PWM output ports, the output pins S4/P4 to S6/P6 as general-purpose output ports, and the output pins S7/P7 and S8/P8 as segment output ports.

(4) CT0 to CT2: Display contrast setting control data

This control data is used to set the display contrast.

CT0 to CT2: Display contrast settings (7 steps)

CT0	CT1	CT2	Level of LCD drive bias 3/3 voltage power supply V_{LCD0}
0	0	0	$1.00V_{LCD} = V_{LCD} - (0.05V_{LCD} \times 0)$
1	0	0	$0.95V_{LCD} = V_{LCD} - (0.05V_{LCD} \times 1)$
0	1	0	$0.90V_{LCD} = V_{LCD} - (0.05V_{LCD} \times 2)$
1	1	0	$0.85V_{LCD} = V_{LCD} - (0.05V_{LCD} \times 3)$
0	0	1	$0.80V_{LCD} = V_{LCD} - (0.05V_{LCD} \times 4)$
1	0	1	$0.75V_{LCD} = V_{LCD} - (0.05V_{LCD} \times 5)$
0	1	1	$0.70V_{LCD} = V_{LCD} - (0.05V_{LCD} \times 6)$

Note that although the contrast of the display can be adjusted by running the internal display contrast adjustment circuit, it is also possible to adjust it by changing the voltage level on the LCD driver block power supply V_{LCD} pin. However, V_{LCD0} must always be greater than or equal to 2.7V.

(5) DR: 1/2 bias drive or 1/3 bias drive switching control data

This control data bit selects either 1/2 bias drive or 1/3 bias drive.

DR	Bias drive scheme
0	1/3 bias drive
1	1/2 bias drive

LC75897PWS-T

(6) DT: 1/3 duty drive or 1/4 duty drive switching control data

This control data bit selects either 1/3 duty drive or 1/4 duty drive.

DT	Duty drive scheme	Output pin state (COM4/S129)
0	1/4 duty drive	COM4
1	1/3 duty drive	S129

Note: COM4: Common output

S129: Segment output

(7) OC: RC oscillator operating mode/external clock operating mode switching control data

This control data bit selects either RC oscillator operating mode or external clock operating mode.

OC	OSC pin function
0	RC oscillator operating mode
1	External clock operating mode

Note: When selecting the RC oscillator operating mode, be sure to connect an external resistor R_{osc} and an external capacitor C_{osc} to the OSC pin.

(8) FC0 to FC2: Common and segment output waveforms frame frequency setting control data

This control data bits set the frame frequency for the common and segment output waveforms.

Control data			Common/segment output waveform frame frequency f_o [Hz]
FC0	FC1	FC2	
0	0	0	$f_{osc}/6144, f_{CK}/6144$
1	0	0	$f_{osc}/4608, f_{CK}/4608$
0	1	0	$f_{osc}/3072, f_{CK}/3072$
1	1	0	$f_{osc}/2304, f_{CK}/2304$
0	0	1	$f_{osc}/1536, f_{CK}/1536$

(9) PF0 to PF2: PWM output waveforms frame frequency setting control data

This control data bits set the frame frequency for the PWM output waveforms.

Control data			PWM output waveform frame frequency f_p [Hz]
PF0	PF1	PF2	
0	0	0	$f_{osc}/1536, f_{CK}/1536$
1	0	0	$f_{osc}/1408, f_{CK}/1408$
0	1	0	$f_{osc}/1280, f_{CK}/1280$
1	1	0	$f_{osc}/1152, f_{CK}/1152$
0	0	1	$f_{osc}/1024, f_{CK}/1024$
1	0	1	$f_{osc}/896, f_{CK}/896$
0	1	1	$f_{osc}/768, f_{CK}/768$
1	1	1	$f_{osc}/640, f_{CK}/640$

(10) SC: Segments on/off control data

This control data bit controls the on/off state of the segments.

SC	Display state
0	On
1	Off

However, note that the segments are turned off by setting SC to 1, the segments are turned off by outputting segment off waveforms from the segment output pins.

(11) BU: Normal mode/power-saving mode control data

This control data bit selects either normal mode or power-saving mode.

BU	Mode
0	Normal mode
1	Power save mode (The LC75897PWS-T stops the oscillation at the OSC pin if it is set up for the RC oscillator operating mode (OC = 0) and stops receiving the external clock if it is set up for the external clock operating mode (OC = 1). The IC also sets the common and segment output pins to the V_{SS} level. The output pins S1/P1 to S8/P8, however, remain available as general-purpose output ports as configured by control data bits PS10, PS11, PS20, PS21, PS30, PS31, PS40, PS41, and PS5 to PS8 (not available as PWM output or clock output ports).)

LC75897PWS-T

Display Data to Segment Output Pin Correspondence

1. 1/3 duty

Segment Output pins	COM1	COM2	COM3	Segment Output pins	COM1	COM2	COM3	Segment Output pins	COM1	COM2	COM3
S1/P1	D1	D2	D3	S44	D130	D131	D132	S87	D259	D260	D261
S2/P2	D4	D5	D6	S45	D133	D134	D135	S88	D262	D263	D264
S3/P3	D7	D8	D9	S46	D136	D137	D138	S89	D265	D266	D267
S4/P4	D10	D11	D12	S47	D139	D140	D141	S90	D268	D269	D270
S5/P5	D13	D14	D15	S48	D142	D143	D144	S91	D271	D272	D273
S6/P6	D16	D17	D18	S49	D145	D146	D147	S92	D274	D275	D276
S7/P7	D19	D20	D21	S50	D148	D149	D150	S93	D277	D278	D279
S8/P8	D22	D23	D24	S51	D151	D152	D153	S94	D280	D281	D282
S9	D25	D26	D27	S52	D154	D155	D156	S95	D283	D284	D285
S10	D28	D29	D30	S53	D157	D158	D159	S96	D286	D287	D288
S11	D31	D32	D33	S54	D160	D161	D162	S97	D289	D290	D291
S12	D34	D35	D36	S55	D163	D164	D165	S98	D292	D293	D294
S13	D37	D38	D39	S56	D166	D167	D168	S99	D295	D296	D297
S14	D40	D41	D42	S57	D169	D170	D171	S100	D298	D299	D300
S15	D43	D44	D45	S58	D172	D173	D174	S101	D301	D302	D303
S16	D46	D47	D48	S59	D175	D176	D177	S102	D304	D305	D306
S17	D49	D50	D51	S60	D178	D179	D180	S103	D307	D308	D309
S18	D52	D53	D54	S61	D181	D182	D183	S104	D310	D311	D312
S19	D55	D56	D57	S62	D184	D185	D186	S105	D313	D314	D315
S20	D58	D59	D60	S63	D187	D188	D189	S106	D316	D317	D318
S21	D61	D62	D63	S64	D190	D191	D192	S107	D319	D320	D321
S22	D64	D65	D66	S65	D193	D194	D195	S108	D322	D323	D324
S23	D67	D68	D69	S66	D196	D197	D198	S109	D325	D326	D327
S24	D70	D71	D72	S67	D199	D200	D201	S110	D328	D329	D330
S25	D73	D74	D75	S68	D202	D203	D204	S111	D331	D332	D333
S26	D76	D77	D78	S69	D205	D206	D207	S112	D334	D335	D336
S27	D79	D80	D81	S70	D208	D209	D210	S113	D337	D338	D339
S28	D82	D83	D84	S71	D211	D212	D213	S114	D340	D341	D342
S29	D85	D86	D87	S72	D214	D215	D216	S115	D343	D344	D345
S30	D88	D89	D90	S73	D217	D218	D219	S116	D346	D347	D348
S31	D91	D92	D93	S74	D220	D221	D222	S117	D349	D350	D351
S32	D94	D95	D96	S75	D223	D224	D225	S118	D352	D353	D354
S33	D97	D98	D99	S76	D226	D227	D228	S119	D355	D356	D357
S34	D100	D101	D102	S77	D229	D230	D231	S120	D358	D359	D360
S35	D103	D104	D105	S78	D232	D233	D234	S121	D361	D362	D363
S36	D106	D107	D108	S79	D235	D236	D237	S122	D364	D365	D366
S37	D109	D110	D111	S80	D238	D239	D240	S123	D367	D368	D369
S38	D112	D113	D114	S81	D241	D242	D243	S124	D370	D371	D372
S39	D115	D116	D117	S82	D244	D245	D246	S125	D373	D374	D375
S40	D118	D119	D120	S83	D247	D248	D249	S126	D376	D377	D378
S41	D121	D122	D123	S84	D250	D251	D252	S127	D379	D380	D381
S42	D124	D125	D126	S85	D253	D254	D255	S128	D382	D383	D384
S43	D127	D128	D129	S86	D256	D257	D258	COM4/S129	D385	D386	D387

Note: This applies to the case where the S1/P1 to S8/P8, and COM4/S129 output pins are set to be segment output ports.

LC75897PWS-T

For example, the table below lists the segment output states for the S11 output pin.

Display data			Segment output pin (S11) state
D31	D32	D33	
0	0	0	The LCD segments corresponding to COM1, COM2, and COM3 are off.
0	0	1	The LCD segment corresponding to COM3 is on.
0	1	0	The LCD segment corresponding to COM2 is on.
0	1	1	The LCD segments corresponding to COM2 and COM3 are on.
1	0	0	The LCD segment corresponding to COM1 is on.
1	0	1	The LCD segments corresponding to COM1 and COM3 are on.
1	1	0	The LCD segments corresponding to COM1 and COM2 are on.
1	1	1	The LCD segments corresponding to COM1, COM2, and COM3 are on.

2. 1/4 duty

Segment Output pins	COM1	COM2	COM3	COM4
S1/P1	D1	D2	D3	D4
S2/P2	D5	D6	D7	D8
S3/P3	D9	D10	D11	D12
S4/P4	D13	D14	D15	D16
S5/P5	D17	D18	D19	D20
S6/P6	D21	D22	D23	D24
S7/P7	D25	D26	D27	D28
S8/P8	D29	D30	D31	D32
S9	D33	D34	D35	D36
S10	D37	D38	D39	D40
S11	D41	D42	D43	D44
S12	D45	D46	D47	D48
S13	D49	D50	D51	D52
S14	D53	D54	D55	D56
S15	D57	D58	D59	D60
S16	D61	D62	D63	D64
S17	D65	D66	D67	D68
S18	D69	D70	D71	D72
S19	D73	D74	D75	D76
S20	D77	D78	D79	D80
S21	D81	D82	D83	D84
S22	D85	D86	D87	D88
S23	D89	D90	D91	D92
S24	D93	D94	D95	D96
S25	D97	D98	D99	D100
S26	D101	D102	D103	D104
S27	D105	D106	D107	D108
S28	D109	D110	D111	D112
S29	D113	D114	D115	D116
S30	D117	D118	D119	D120
S31	D121	D122	D123	D124
S32	D125	D126	D127	D128
S33	D129	D130	D131	D132
S34	D133	D134	D135	D136
S35	D137	D138	D139	D140
S36	D141	D142	D143	D144

Segment Output pins	COM1	COM2	COM3	COM4
S37	D145	D146	D147	D148
S38	D149	D150	D151	D152
S39	D153	D154	D155	D156
S40	D157	D158	D159	D160
S41	D161	D162	D163	D164
S42	D165	D166	D167	D168
S43	D169	D170	D171	D172
S44	D173	D174	D175	D176
S45	D177	D178	D179	D180
S46	D181	D182	D183	D184
S47	D185	D186	D187	D188
S48	D189	D190	D191	D192
S49	D193	D194	D195	D196
S50	D197	D198	D199	D200
S51	D201	D202	D203	D204
S52	D205	D206	D207	D208
S53	D209	D210	D211	D212
S54	D213	D214	D215	D216
S55	D217	D218	D219	D220
S56	D221	D222	D223	D224
S57	D225	D226	D227	D228
S58	D229	D230	D231	D232
S59	D233	D234	D235	D236
S60	D237	D238	D239	D240
S61	D241	D242	D243	D244
S62	D245	D246	D247	D248
S63	D249	D250	D251	D252
S64	D253	D254	D255	D256
S65	D257	D258	D259	D260
S66	D261	D262	D263	D264
S67	D265	D266	D267	D268
S68	D269	D270	D271	D272
S69	D273	D274	D275	D276
S70	D277	D278	D279	D280
S71	D281	D282	D283	D284
S72	D285	D286	D287	D288

Continued on next page.

LC75897PWS-T

Continued from preceding page.

Segment Output pins	COM1	COM2	COM3	COM4
S73	D289	D290	D291	D292
S74	D293	D294	D295	D296
S75	D297	D298	D299	D300
S76	D301	D302	D303	D304
S77	D305	D306	D307	D308
S78	D309	D310	D311	D312
S79	D313	D314	D315	D316
S80	D317	D318	D319	D320
S81	D321	D322	D323	D324
S82	D325	D326	D327	D328
S83	D329	D330	D331	D332
S84	D333	D334	D335	D336
S85	D337	D338	D339	D340
S86	D341	D342	D343	D344
S87	D345	D346	D347	D348
S88	D349	D350	D351	D352
S89	D353	D354	D355	D356
S90	D357	D358	D359	D360
S91	D361	D362	D363	D364
S92	D365	D366	D367	D368
S93	D369	D370	D371	D372
S94	D373	D374	D375	D376
S95	D377	D378	D379	D380
S96	D381	D382	D383	D384
S97	D385	D386	D387	D388
S98	D389	D390	D391	D392
S99	D393	D394	D395	D396
S100	D397	D398	D399	D400

Segment Output pins	COM1	COM2	COM3	COM4
S101	D401	D402	D403	D404
S102	D405	D406	D407	D408
S103	D409	D410	D411	D412
S104	D413	D414	D415	D416
S105	D417	D418	D419	D420
S106	D421	D422	D423	D424
S107	D425	D426	D427	D428
S108	D429	D430	D431	D432
S109	D433	D434	D435	D436
S110	D437	D438	D439	D440
S111	D441	D442	D443	D444
S112	D445	D446	D447	D448
S113	D449	D450	D451	D452
S114	D453	D454	D455	D456
S115	D457	D458	D459	D460
S116	D461	D462	D463	D464
S117	D465	D466	D467	D468
S118	D469	D470	D471	D472
S119	D473	D474	D475	D476
S120	D477	D478	D479	D480
S121	D481	D482	D483	D484
S122	D485	D486	D487	D488
S123	D489	D490	D491	D492
S124	D493	D494	D495	D496
S125	D497	D498	D499	D500
S126	D501	D502	D503	D504
S127	D505	D506	D507	D508
S128	D509	D510	D511	D512

Note: This applies to the case where the S1/P1 to S8/P8 output pins are set to be segment output ports.

For example, the table below lists the segment output states for the S11 output pin.

Display data				Segment output pin (S11) state
D41	D42	D43	D44	
0	0	0	0	The LCD segments corresponding to COM1, COM2, COM3, and COM4 are off.
0	0	0	1	The LCD segment corresponding to COM4 is on.
0	0	1	0	The LCD segment corresponding to COM3 is on.
0	0	1	1	The LCD segments corresponding to COM3 and COM4 are on.
0	1	0	0	The LCD segment corresponding to COM2 is on.
0	1	0	1	The LCD segments corresponding to COM2 and COM4 are on.
0	1	1	0	The LCD segments corresponding to COM2 and COM3 are on.
0	1	1	1	The LCD segments corresponding to COM2, COM3, and COM4 are on.
1	0	0	0	The LCD segment corresponding to COM1 is on.
1	0	0	1	The LCD segments corresponding to COM1 and COM4 are on.
1	0	1	0	The LCD segments corresponding to COM1 and COM3 are on.
1	0	1	1	The LCD segments corresponding to COM1, COM3, and COM4 are on.
1	1	0	0	The LCD segments corresponding to COM1 and COM2 are on.
1	1	0	1	The LCD segments corresponding to COM1, COM2, and COM4 are on.
1	1	1	0	The LCD segments corresponding to COM1, COM2, and COM3 are on.
1	1	1	1	The LCD segments corresponding to COM1, COM2, COM3, and COM4 are on.

LC75897PWS-T

Output Waveforms (1/3-Duty 1/2-Bias Drive Scheme)

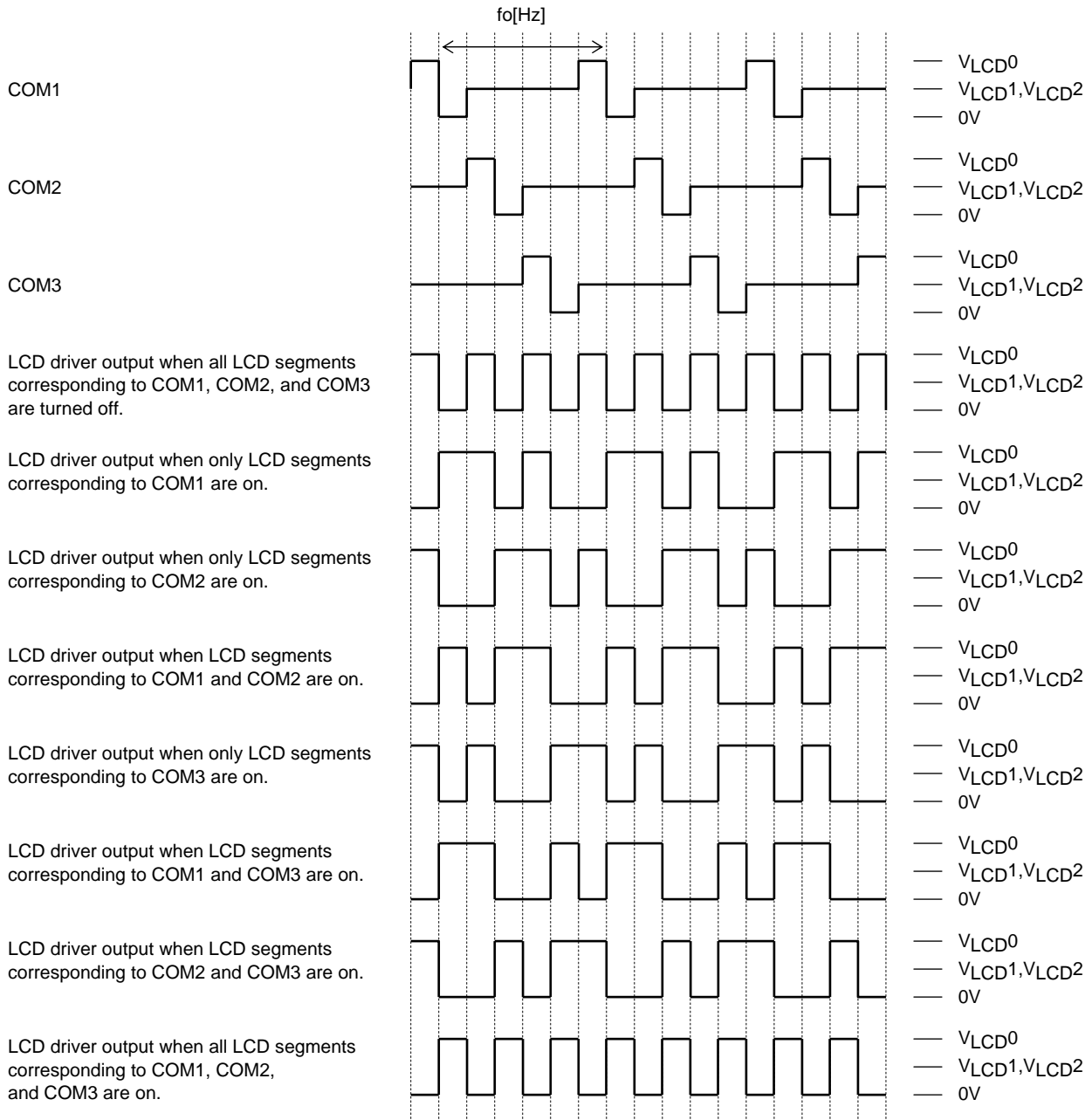

Control data			Common/segment output waveform frame frequency f_o [Hz]
FC0	FC1	FC2	
0	0	0	$f_{osc}/6144, f_{CK}/6144$
1	0	0	$f_{osc}/4608, f_{CK}/4608$
0	1	0	$f_{osc}/3072, f_{CK}/3072$
1	1	0	$f_{osc}/2304, f_{CK}/2304$
0	0	1	$f_{osc}/1536, f_{CK}/1536$

LC75897PWS-T

Output Waveforms (1/3-Duty 1/3-Bias Drive Scheme)

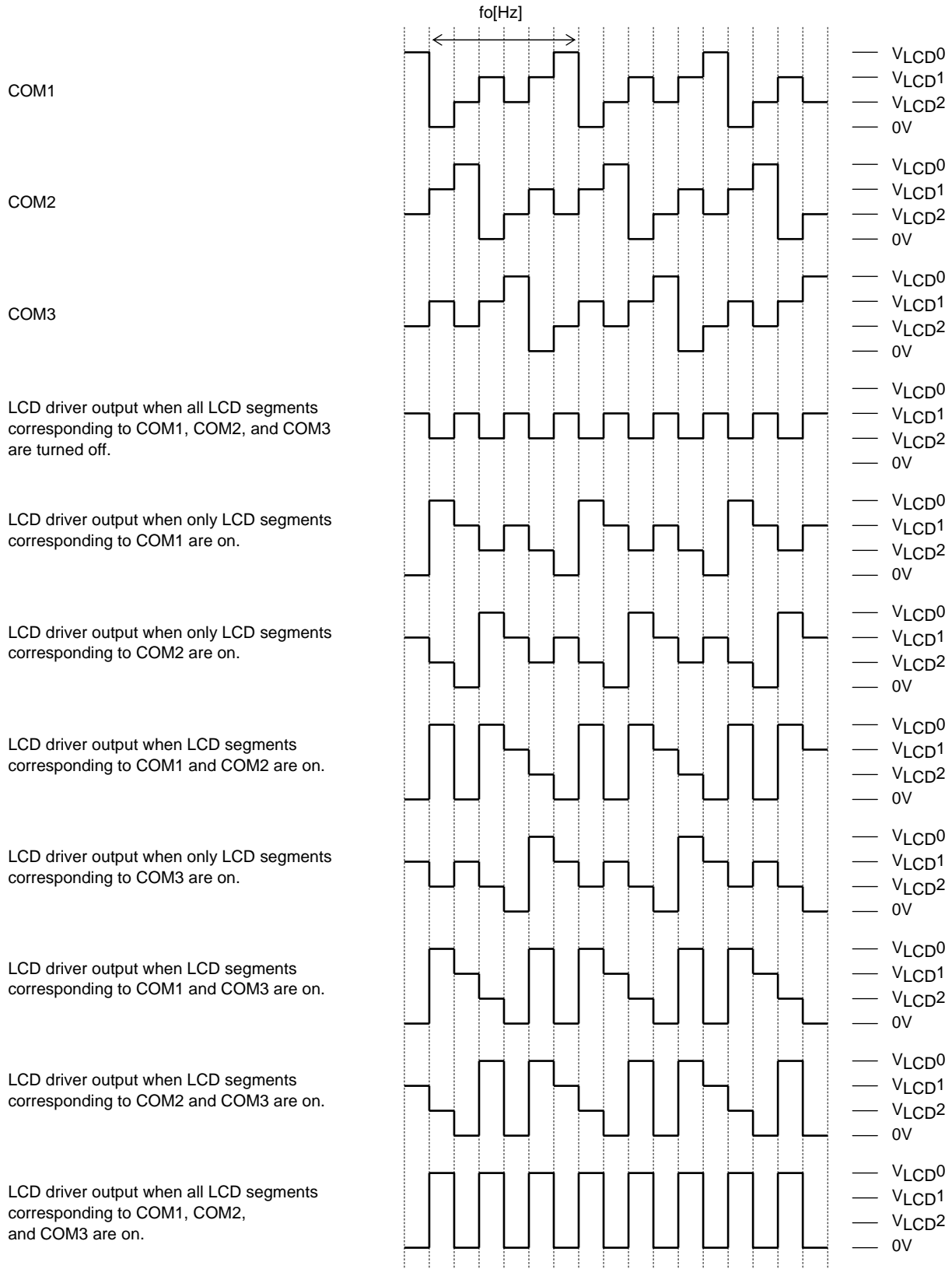

Control data			Common/segment output waveform frame frequency f_o [Hz]
FC0	FC1	FC2	
0	0	0	$f_{osc}/6144, f_{CK}/6144$
1	0	0	$f_{osc}/4608, f_{CK}/4608$
0	1	0	$f_{osc}/3072, f_{CK}/3072$
1	1	0	$f_{osc}/2304, f_{CK}/2304$
0	0	1	$f_{osc}/1536, f_{CK}/1536$

LC75897PWS-T

Output Waveforms (1/4-Duty 1/2-Bias Drive Scheme)

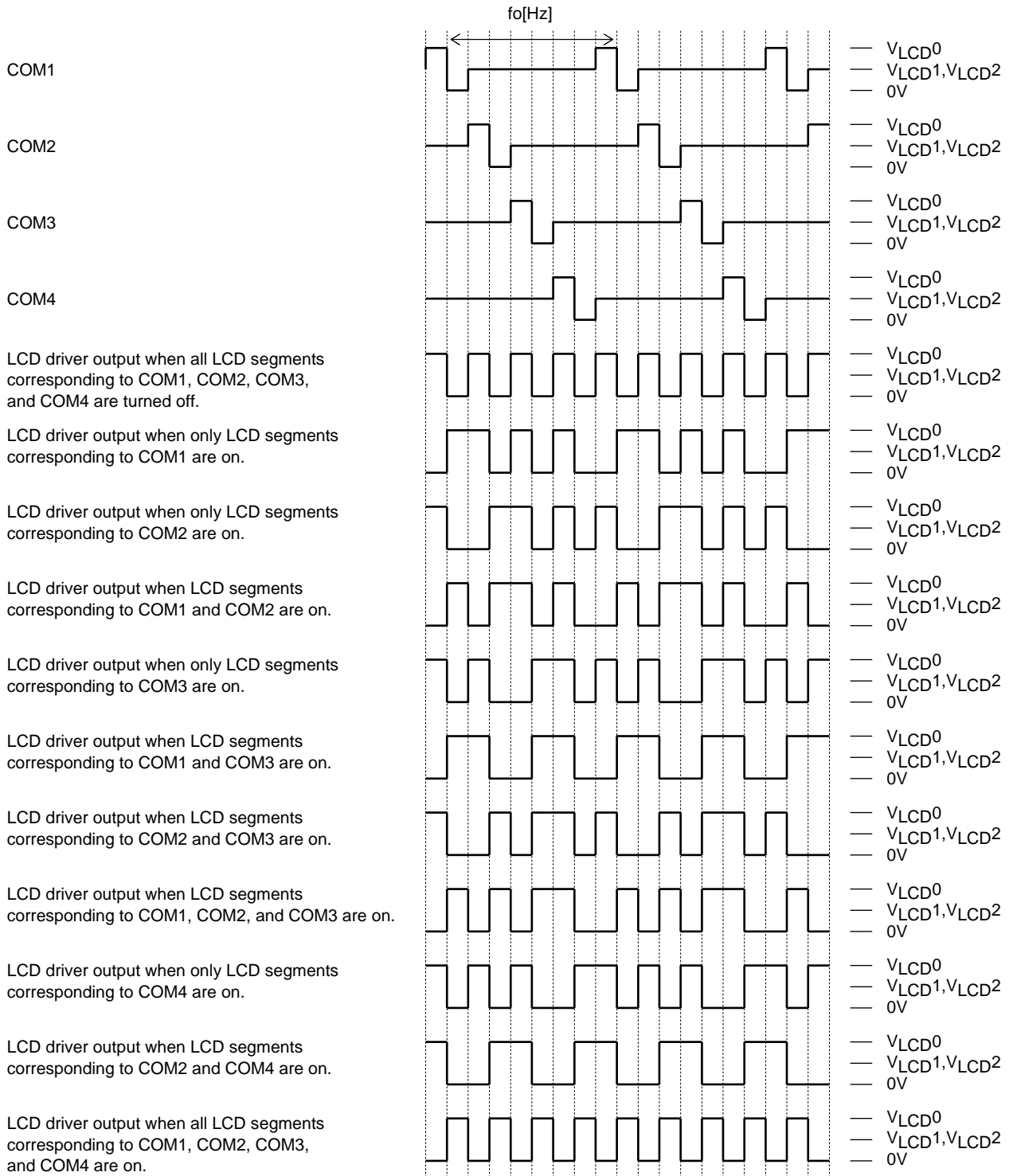

Control data			Common/segment output waveform frame frequency f_o [Hz]
FC0	FC1	FC2	
0	0	0	$f_{osc}/6144, f_{CK}/6144$
1	0	0	$f_{osc}/4608, f_{CK}/4608$
0	1	0	$f_{osc}/3072, f_{CK}/3072$
1	1	0	$f_{osc}/2304, f_{CK}/2304$
0	0	1	$f_{osc}/1536, f_{CK}/1536$

LC75897PWS-T

Output Waveforms (1/4-Duty 1/3-Bias Drive Scheme)

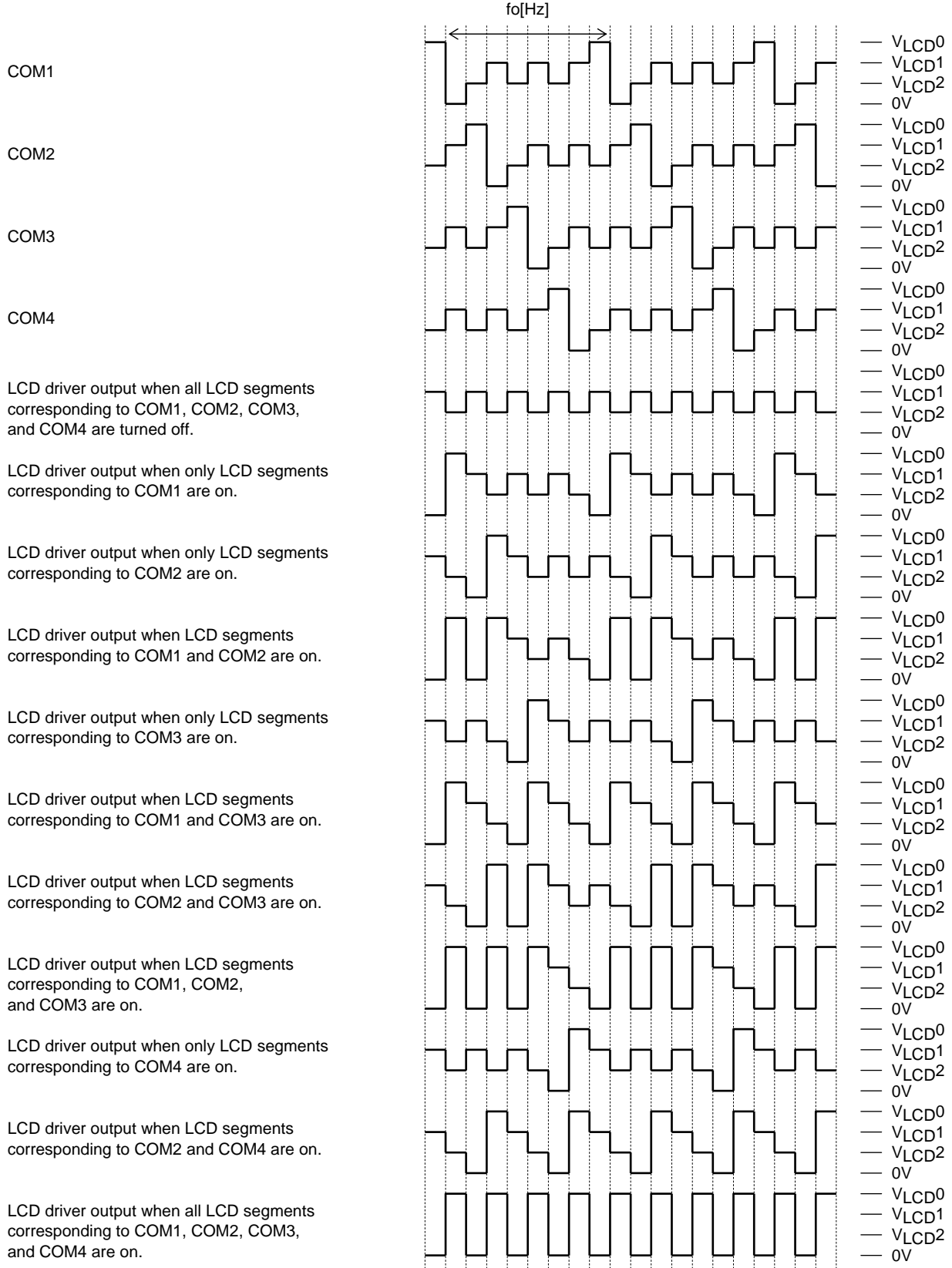

Control data			Common/segment output waveform frame frequency f_o [Hz]
FC0	FC1	FC2	
0	0	0	$f_{osc}/6144, f_{CK}/6144$
1	0	0	$f_{osc}/4608, f_{CK}/4608$
0	1	0	$f_{osc}/3072, f_{CK}/3072$
1	1	0	$f_{osc}/2304, f_{CK}/2304$
0	0	1	$f_{osc}/1536, f_{CK}/1536$

LC75897PWS-T

PWM output port waveforms

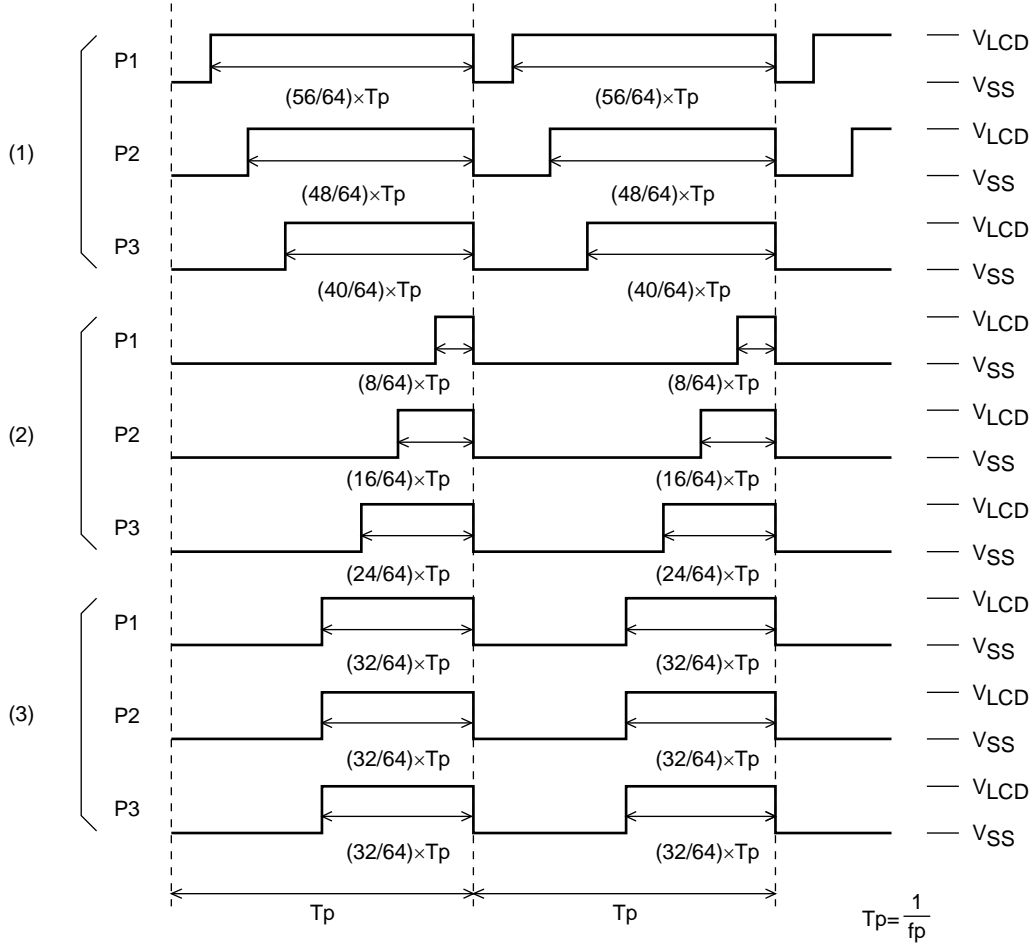

Control data																		PWM output port waveforms
W10	W11	W12	W13	W14	W15	W20	W21	W22	W23	W24	W25	W30	W31	W32	W33	W34	W35	
1	1	1	0	1	1	1	1	1	1	0	1	1	1	1	0	0	1	(1)
1	1	1	0	0	0	1	1	1	1	0	0	1	1	1	0	1	0	(2)
1	1	1	1	1	0	1	1	1	1	1	0	1	1	1	1	1	0	(3)

Control data			PWM output waveform frame frequency fp [Hz]
PF0	PF1	PF2	
0	0	0	fosc/1536, fCK/1536
1	0	0	fosc/1408, fCK/1408
0	1	0	fosc/1280, fCK/1280
1	1	0	fosc/1152, fCK/1152
0	0	1	fosc/1024, fCK/1024
1	0	1	fosc/896, fCK/896
0	1	1	fosc/768, fCK/768
1	1	1	fosc/640, fCK/640

Control data		Clock output port P4 clock signal frequency fc (=1/Tc) [Hz]
PS40	PF41	
0	1	Clock output port (fosc/2, fCK/2)
1	1	Clock output port (fosc/8, fCK/8)

Clock output port waveform

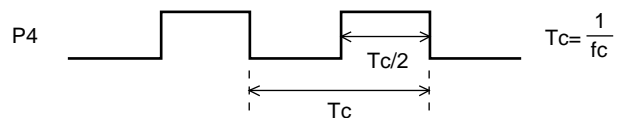

LC75897PWS-T

The $\overline{\text{INH}}$ pin and Display Control

Since the IC internal data (1/3 duty: the display data D1 to D387 and the control data, 1/4 duty: the display data D1 to D512 and the control data) is undefined when power is first applied, applications should set the $\overline{\text{INH}}$ pin low at the same time as power is applied to turn off the display (This sets the S1/P1 to S8/P8, S9 to S128, COM1 to COM3, and COM4/S129 to the V_{SS} level.) and during this period send serial data from the controller. The controller should then set the $\overline{\text{INH}}$ pin high after the data transfer has completed. This procedure prevents meaningless displays at power on. (See Figures 5 and 6.)

Notes on the Power On/Off Sequences

Applications should observe the following sequences when turning the LC75897PWS-T power on and off. (See Figures 5 and 6)

- At power on: Logic block power supply (V_{DD}) on \rightarrow LCD driver block power supply (V_{LCD}) on
- At power off: LCD driver block power supply (V_{LCD}) off \rightarrow Logic block power supply (V_{DD}) off

However, if the logic and LCD driver block use a shared power supply, then the power supplies can be turned on and off at the same time.

1. 1/3 duty

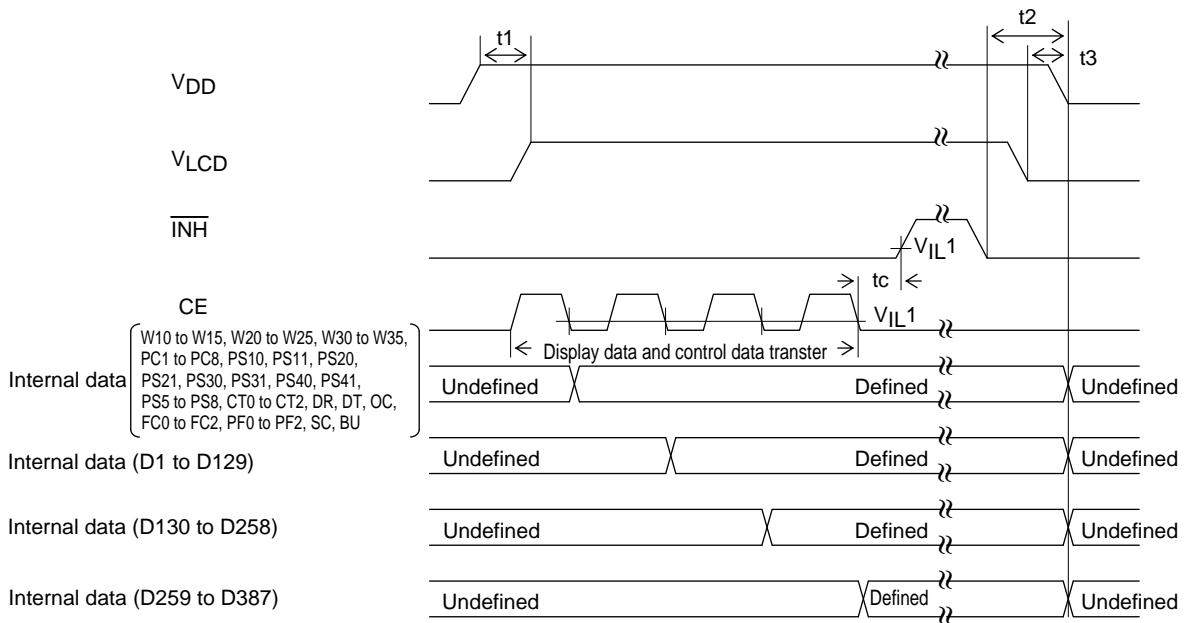

Note: $t_1 \geq 0$
 $t_2 > 0$
 $t_3 \geq 0$ ($t_2 > t_3$)
 $t_c \dots 10\mu\text{s min}$

Figure 5

LC75897PWS-T

2. 1/4 duty

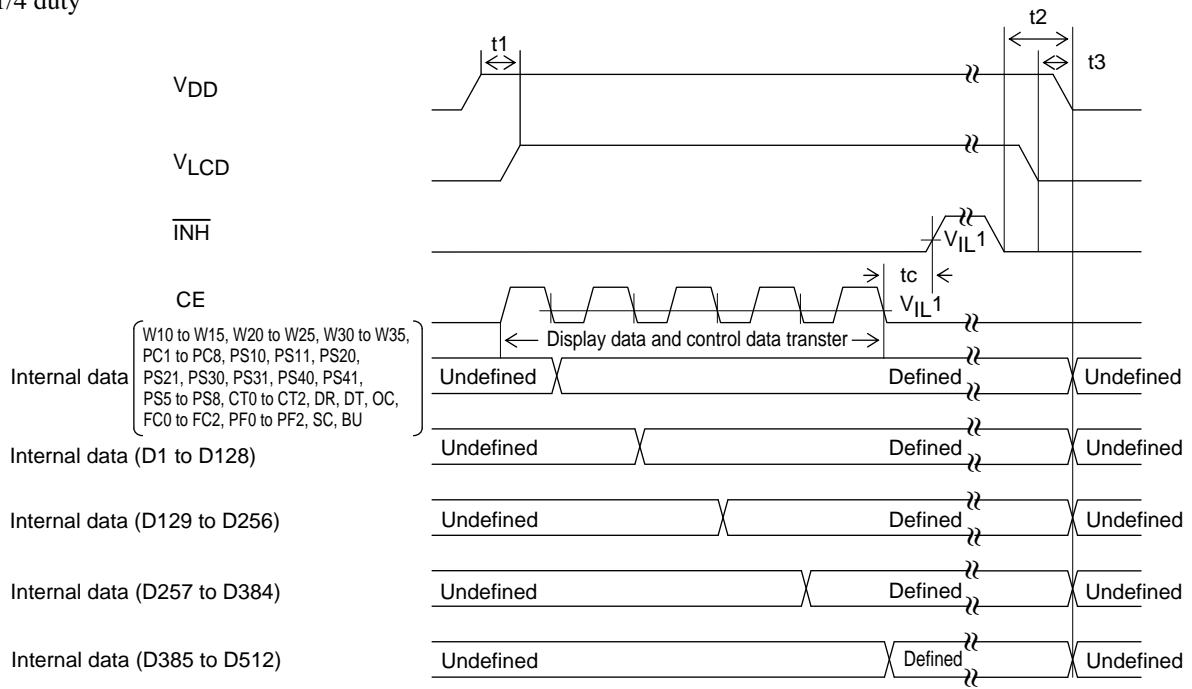

Note: $t_1 \geq 0$
 $t_2 > 0$
 $t_3 \geq 0$ ($t_2 > t_3$)
 $t_c \dots 10\mu\text{s min}$

Figure 6

LC75897PWS-T

Notes on Controller Transfer of Display Data

Since the LC75897PWS-T accepts the display data (D1 to D387) divided into three separate transfer operations when using 1/3 duty drive scheme and the data (D1 to D512) divided into four separate transfer operations when using 1/4 duty drive scheme, we recommend that applications transfer all of the display data within a period of less than 30ms to prevent observable degradation of display quality.

OSC pin peripheral circuits

(1) RC oscillator operating mode (control data OC = 0)

When RC oscillator operating mode is selected, an external resistor R_{osc} and an external capacitor C_{osc} must be connected between the OSC pin and GND.

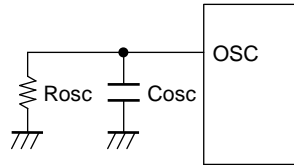

(2) External clock operating mode (control data OC = 1)

When selecting the external clock operating mode, connect a current protection resistor R_g (2.2 to 22k Ω) between the OSC pin and the external clock output pin (external oscillator). Determine the value of the resistance according to the maximum allowable current value of the external clock output pin. Also make sure that the waveform of the external clock is not excessively distorted.

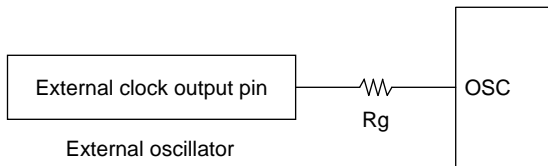

Note:
Allowable current value at external clock output pin $> \frac{V_{DD}}{R_g}$

P1 to P3 pin peripheral circuit

It is recommended the circuit shown below be used to adjust the brightness of the LED backlight using PWM output ports P1 to P3.

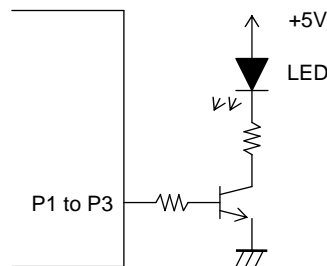

LC75897PWS-T

Sample Application Circuit 1

1/3 Duty, 1/2 Bias (for use with normal panels)

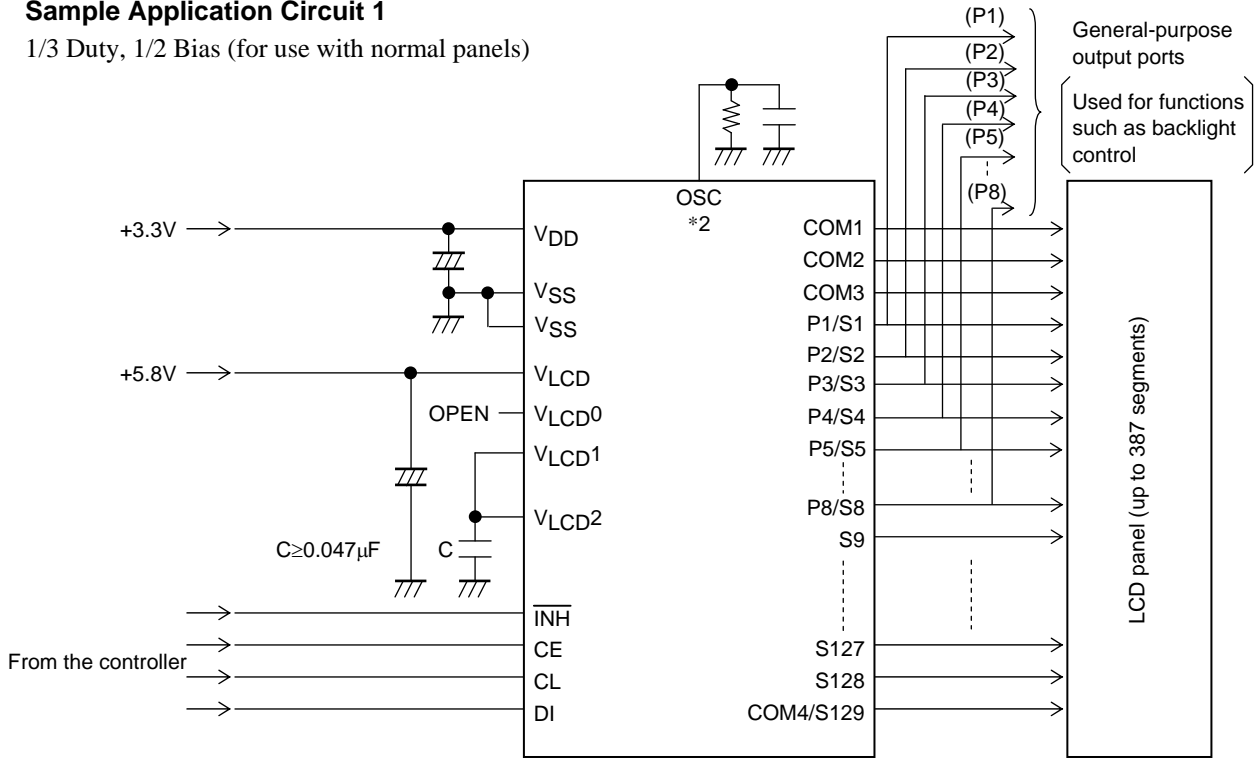

Note: *2 Connect an external resistor R_{osc} and an external capacitor C_{osc} between the OSC pin and GND when selecting the RC oscillator operating mode and connect a current protection resistor R_g (2.2 to 22k Ω) between the OSC pin and the external clock output pin (external oscillator) when selecting the external clock operating mode (see the note on the OSC pin peripheral circuits).

Sample Application Circuit 2

1/3 Duty, 1/2 Bias (for use with large panels)

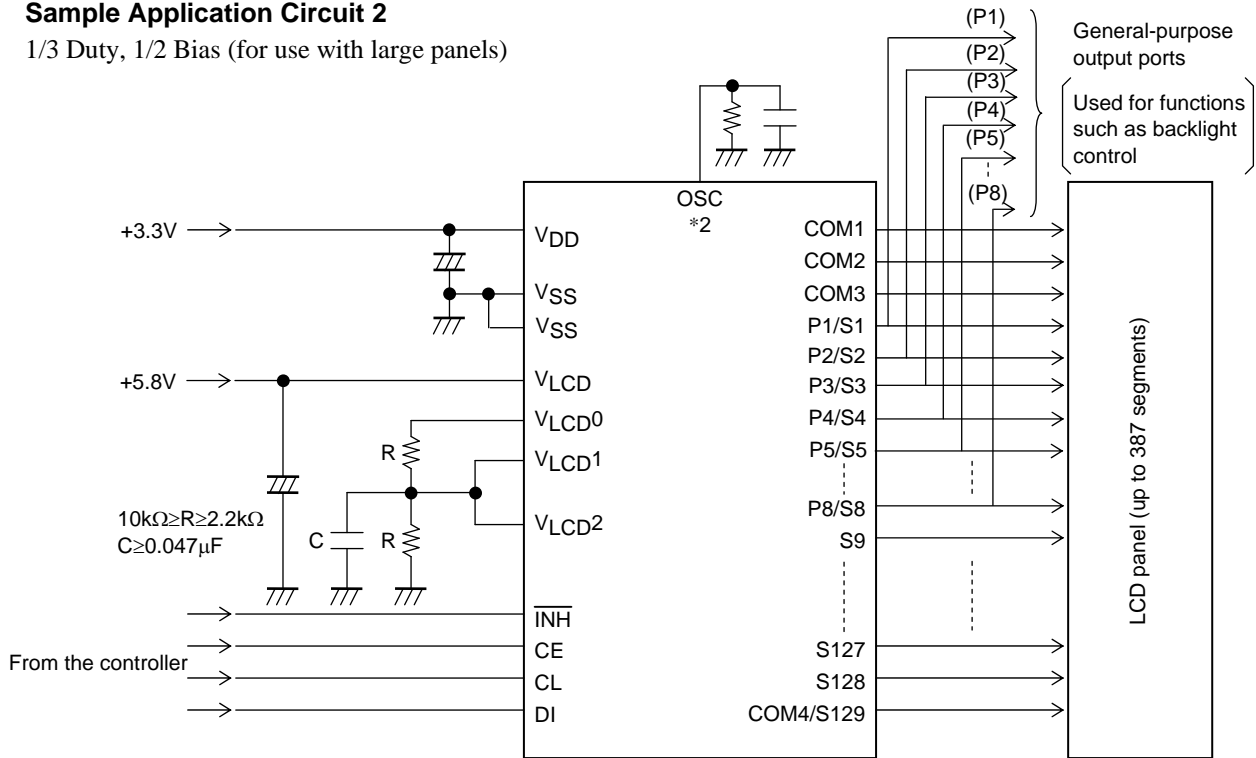

Note: *2 Connect an external resistor R_{osc} and an external capacitor C_{osc} between the OSC pin and GND when selecting the RC oscillator operating mode and connect a current protection resistor R_g (2.2 to 22k Ω) between the OSC pin and the external clock output pin (external oscillator) when selecting the external clock operating mode (see the note on the OSC pin peripheral circuits).

LC75897PWS-T

Sample Application Circuit 3

1/3 Duty, 1/3 Bias (for use with normal panels)

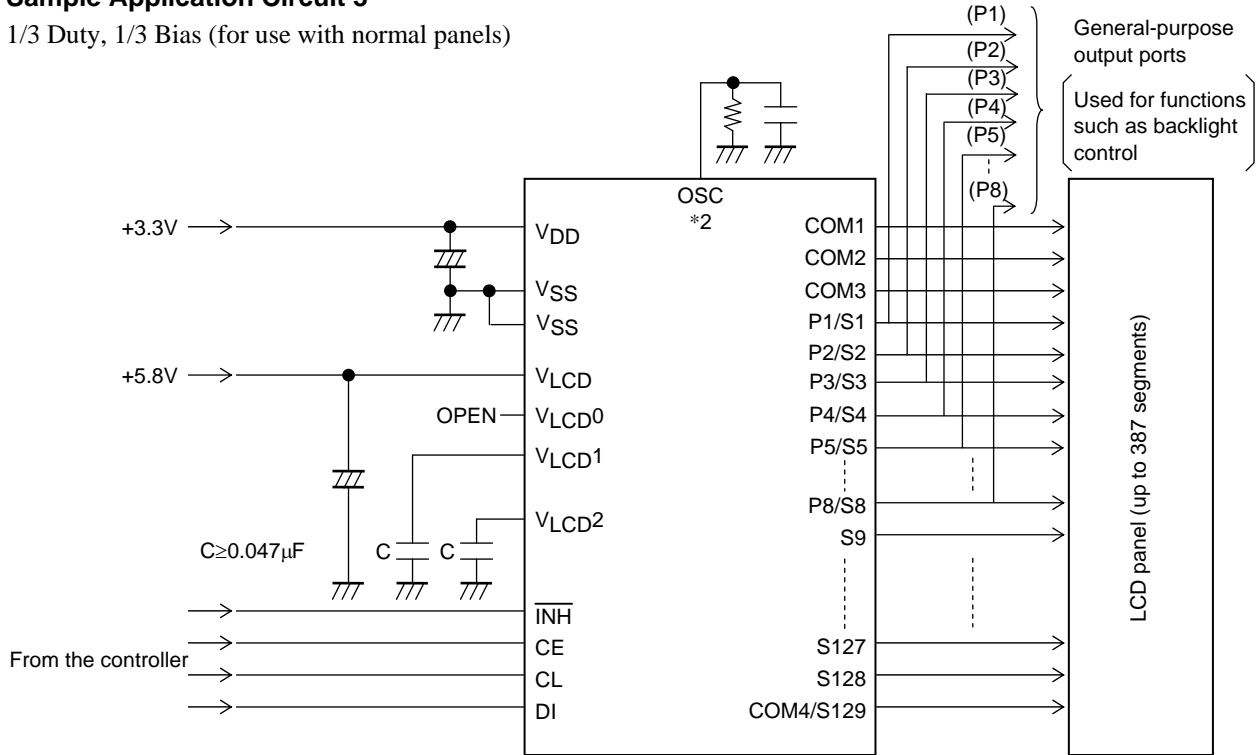

Note: *2 Connect an external resistor R_{osc} and an external capacitor C_{osc} between the OSC pin and GND when selecting the RC oscillator operating mode and connect a current protection resistor R_g (2.2 to 22k Ω) between the OSC pin and the external clock output pin (external oscillator) when selecting the external clock operating mode (see the note on the OSC pin peripheral circuits).

Sample Application Circuit 4

1/3 Duty, 1/3 Bias (for use with large panels)

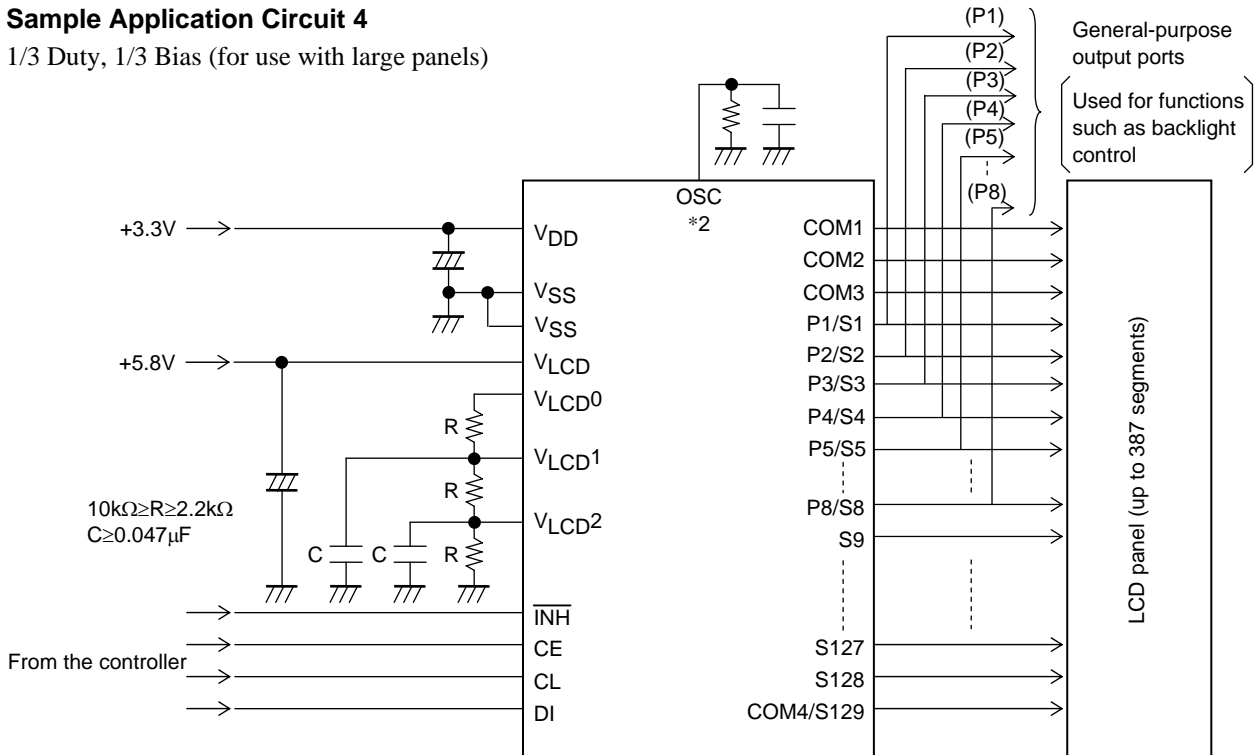

Note: *2 Connect an external resistor R_{osc} and an external capacitor C_{osc} between the OSC pin and GND when selecting the RC oscillator operating mode and connect a current protection resistor R_g (2.2 to 22k Ω) between the OSC pin and the external clock output pin (external oscillator) when selecting the external clock operating mode (see the note on the OSC pin peripheral circuits).

LC75897PWS-T

Sample Application Circuit 5

1/4 Duty, 1/2 Bias (for use with normal panels)

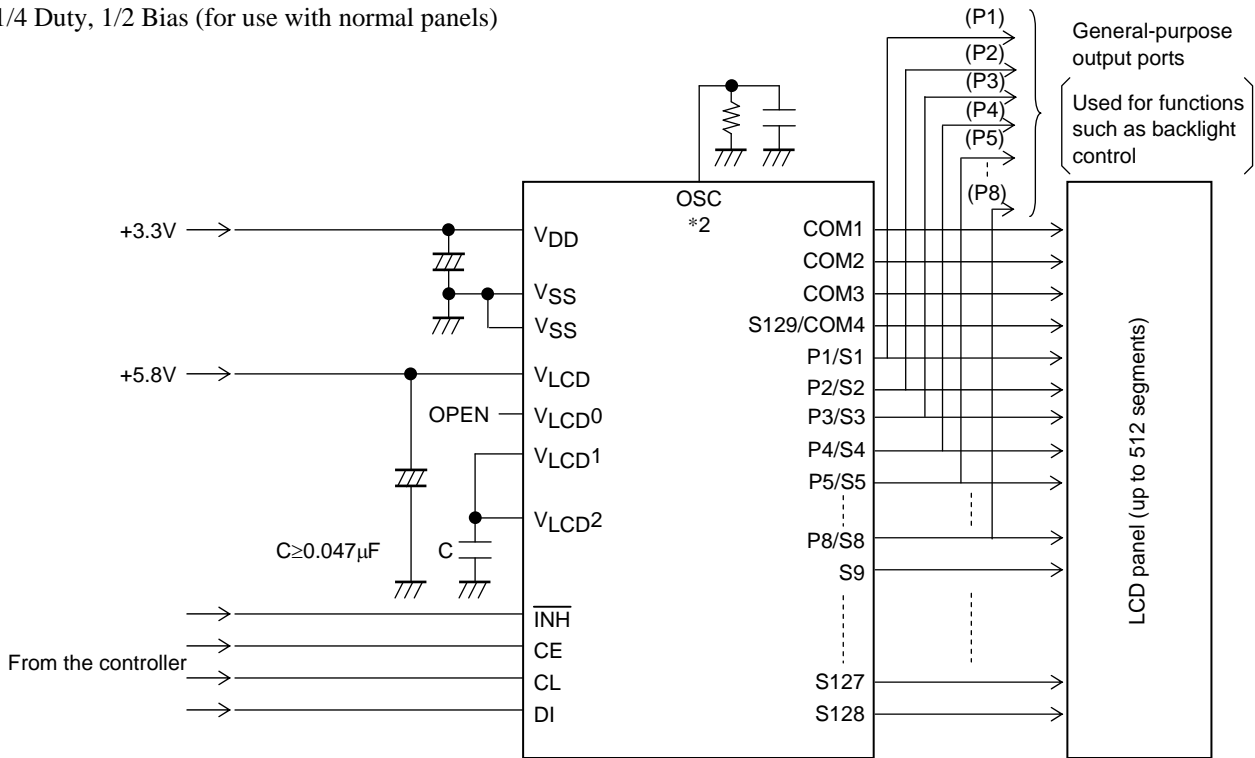

Note: *2 Connect an external resistor R_{osc} and an external capacitor C_{osc} between the OSC pin and GND when selecting the RC oscillator operating mode and connect a current protection resistor R_g (2.2 to 22k Ω) between the OSC pin and the external clock output pin (external oscillator) when selecting the external clock operating mode (see the note on the OSC pin peripheral circuits).

Sample Application Circuit 6

1/4 Duty, 1/2 Bias (for use with large panels)

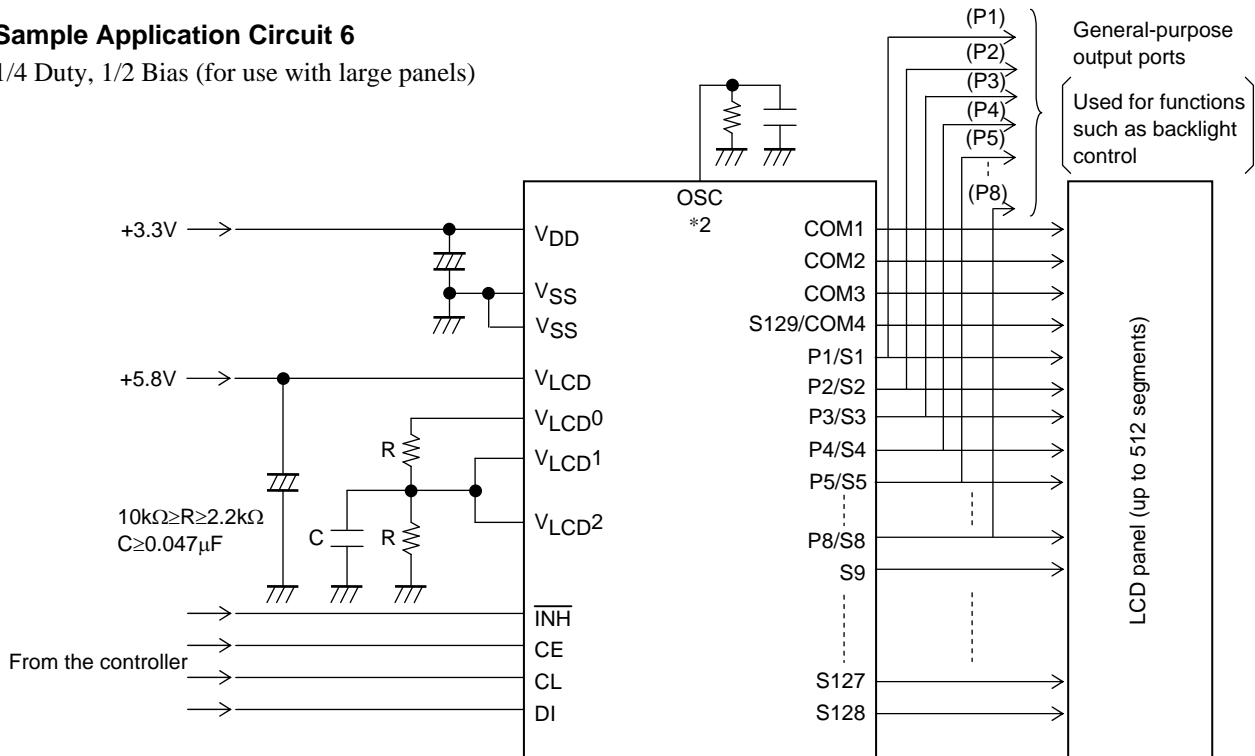

Note: *2 Connect an external resistor R_{osc} and an external capacitor C_{osc} between the OSC pin and GND when selecting the RC oscillator operating mode and connect a current protection resistor R_g (2.2 to 22k Ω) between the OSC pin and the external clock output pin (external oscillator) when selecting the external clock operating mode (see the note on the OSC pin peripheral circuits).

LC75897PWS-T

Sample Application Circuit 7

1/4 Duty, 1/3 Bias (for use with normal panels)

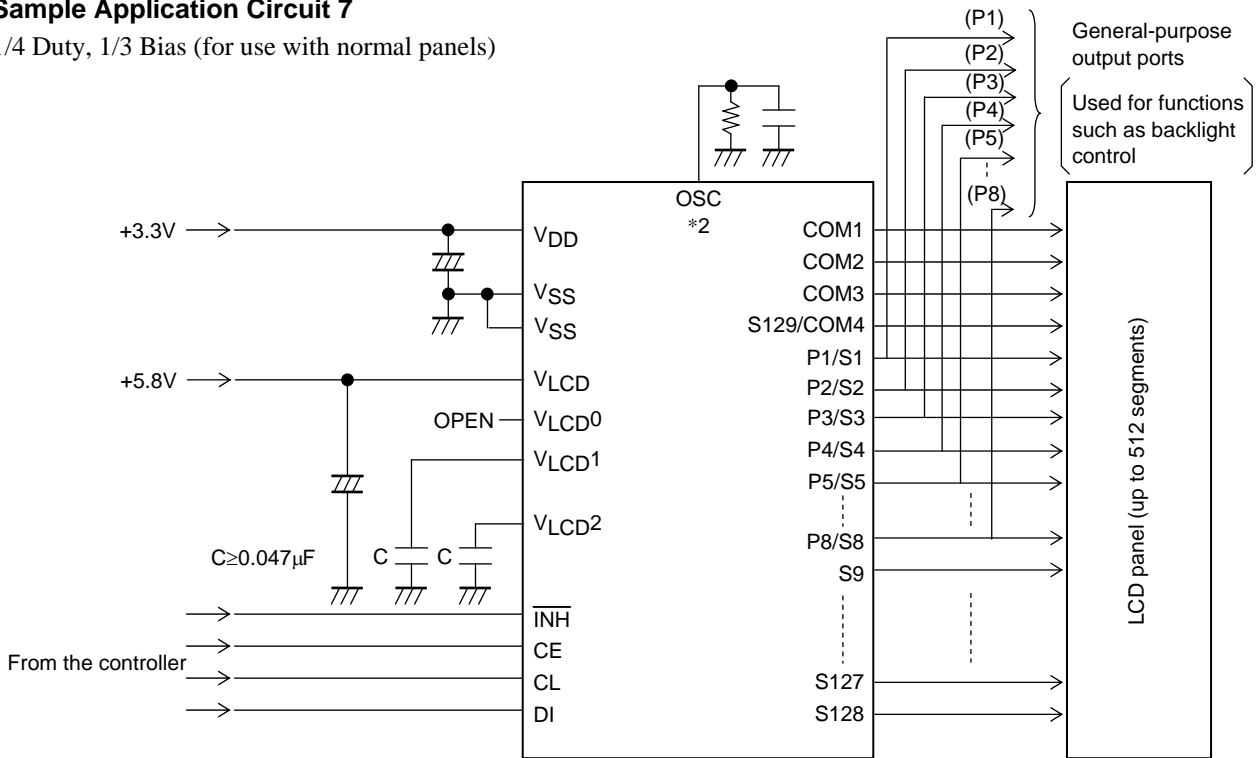

Note: *2 Connect an external resistor R_{osc} and an external capacitor C_{osc} between the OSC pin and GND when selecting the RC oscillator operating mode and connect a current protection resistor R_g (2.2 to 22kΩ) between the OSC pin and the external clock output pin (external oscillator) when selecting the external clock operating mode (see the note on the OSC pin peripheral circuits).

Sample Application Circuit 8

1/4 Duty, 1/3 Bias (for use with large panels)

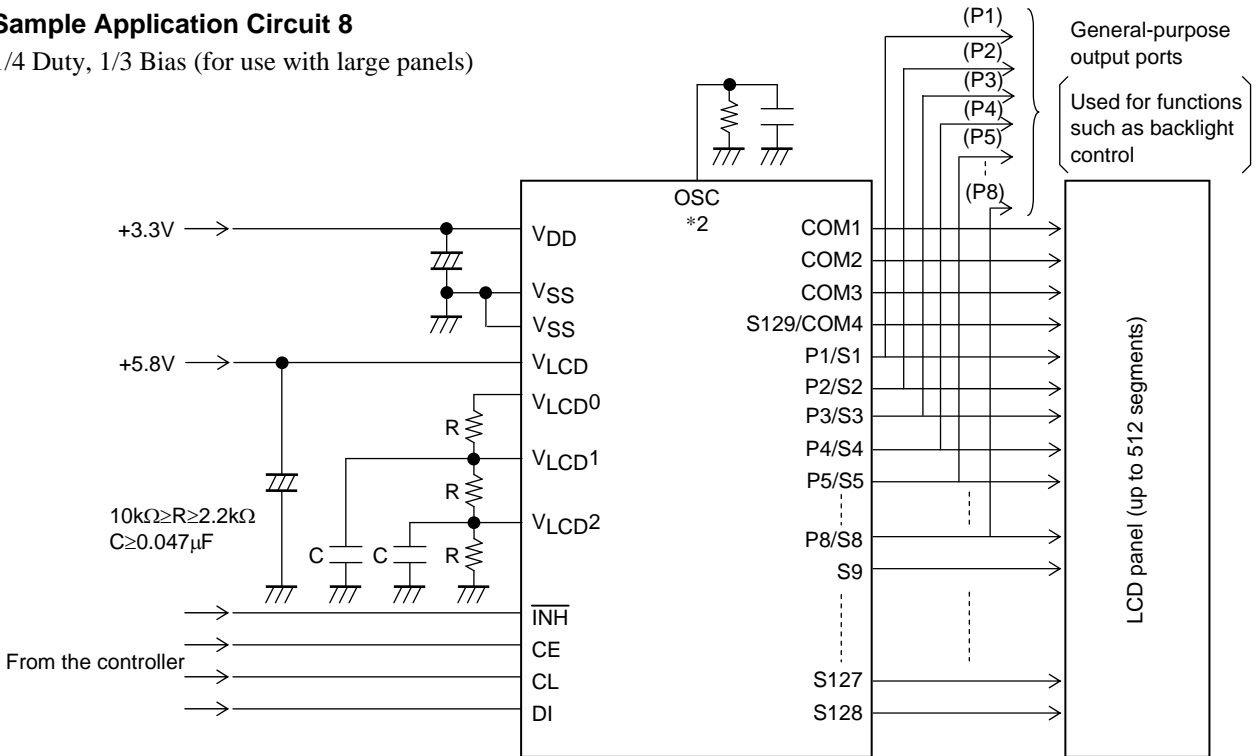

Note: *2 Connect an external resistor R_{osc} and an external capacitor C_{osc} between the OSC pin and GND when selecting the RC oscillator operating mode and connect a current protection resistor R_g (2.2 to 22kΩ) between the OSC pin and the external clock output pin (external oscillator) when selecting the external clock operating mode (see the note on the OSC pin peripheral circuits).

LC75897PWS-T

Package Dimensions

unit : mm

SPQFP144 20x20 / SQFP144

CASE 131AD

ISSUE A

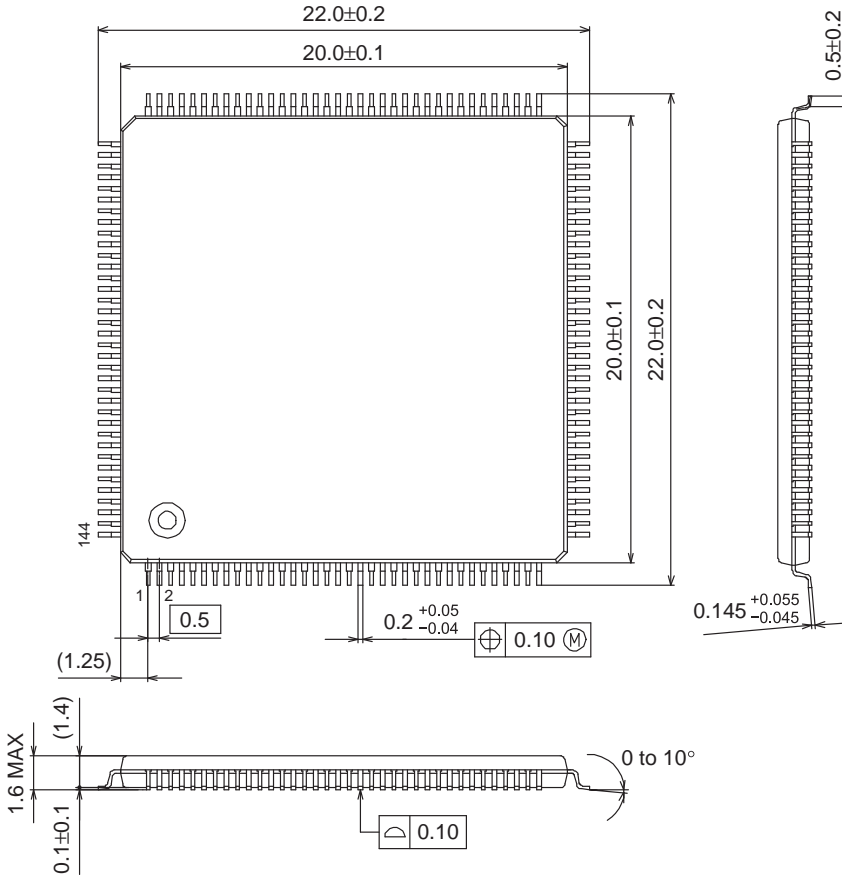

SOLDERING FOOTPRINT*

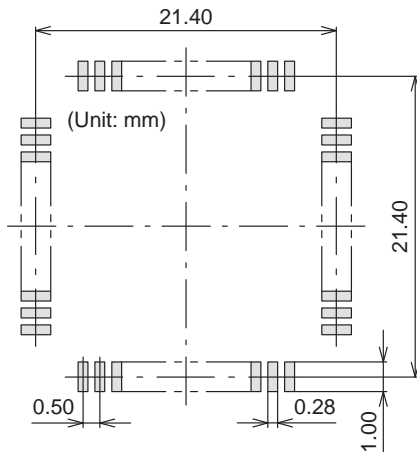

GENERIC MARKING DIAGRAM*

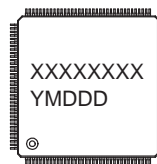

XXXXX = Specific Device Code
 Y = Year
 M = Month
 DDD = Additional Traceability Data

*This information is generic. Please refer to device data sheet for actual part marking. Pb-Free indicator, "G" or microdot "▪", may or may not be present.

NOTE: The measurements are not to guarantee but for reference only.

*For additional information on our Pb-Free strategy and soldering details, please download the ON Semiconductor Soldering and Mounting Techniques Reference Manual, SOLDERRM/D.

LC75897PWS-T

ORDERING INFORMATION

Device	Package	Shipping (Qty / Packing)
LC75897PWS-T-E	SPQFP144 20x20 / SQFP144 (Pb-Free)	200 / Tray Foam

ON Semiconductor and the ON logo are registered trademarks of Semiconductor Components Industries, LLC (SCILLC) or its subsidiaries in the United States and/or other countries. SCILLC owns the rights to a number of patents, trademarks, copyrights, trade secrets, and other intellectual property. A listing of SCILLC's product/patent coverage may be accessed at www.onsemi.com/site/pdf/Patent-Marking.pdf. SCILLC reserves the right to make changes without further notice to any products herein. SCILLC makes no warranty, representation or guarantee regarding the suitability of its products for any particular purpose, nor does SCILLC assume any liability arising out of the application or use of any product or circuit, and specifically disclaims any and all liability, including without limitation special, consequential or incidental damages. "Typical" parameters which may be provided in SCILLC data sheets and/or specifications can and do vary in different applications and actual performance may vary over time. All operating parameters, including "Typicals" must be validated for each customer application by customer's technical experts. SCILLC does not convey any license under its patent rights nor the rights of others. SCILLC products are not designed, intended, or authorized for use as components in systems intended for surgical implant into the body, or other applications intended to support or sustain life, or for any other application in which the failure of the SCILLC product could create a situation where personal injury or death may occur. Should Buyer purchase or use SCILLC products for any such unintended or unauthorized application, Buyer shall indemnify and hold SCILLC and its officers, employees, subsidiaries, affiliates, and distributors harmless against all claims, costs, damages, and expenses, and reasonable attorney fees arising out of, directly or indirectly, any claim of personal injury or death associated with such unintended or unauthorized use, even if such claim alleges that SCILLC was negligent regarding the design or manufacture of the part. SCILLC is an Equal Opportunity/Affirmative Action Employer. This literature is subject to all applicable copyright laws and is not for resale in any manner.