

Low Noise Amplifier for Satellite Communication

Features

- Operating frequency:
L-Band: 1518MHz to 1559MHz
S-Band: 2170MHz to 2500MHz
- Noise figure: 0.55dB@L-Band, 0.65dB@S-Band
- High power gain: 23dB@L-Band, 19dB@S-Band
- Output 1dB-compression point: 8.5dBm@L-Band, 8dBm@S-Band
- Output 3rd-order intercept point: 19dBm@L-Band, 20dBm@S-Band
- Supply voltage: 1.6V to 3.1V
- Input and output DC decoupled
- DFN 1.1X0.7-6L

Applications

- Cell phones
- Satellite communication
- Handheld device
- Other RF front-end modules

General Description

- The AW15195DNR is a low noise amplifier for satellite communication. The AW15195DNR requires only one external input matching inductor at L or S band, reduces assembly complexity and the PCB area, enabling a cost-effective solution.
- The AW15195DNR achieves low noise figure, high linearity, high gain, over a wide range of supply voltages from 1.6V to 3.1V. All these features make AW15195DNR an excellent choice for satellite communication application as it improves sensitivity with low noise figure and high gain, provides better immunity against jammer signals with high linearity, reduces filtering requirement of preceding stage and hence reduces the overall cost.
- The AW15195DNR is available in a small lead-free, RoHS-Compliant, DFN 1.1X0.7-6L.

Typical Application Circuit

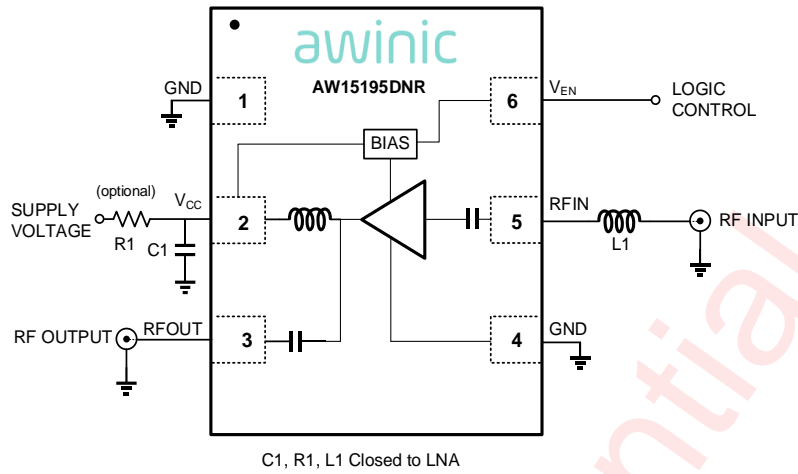

Figure 1 Typical Application Circuit of AW15195DNR for L or S band

Inductor Selection Table for L or S band

Part	Serial	Typical(nH)	MFR	Size(inch)	Frequency range(MHz)
L1	LQW15A	6.9	Murata	0402	1518~1559
L1	LQW15A	3.5	Murata	0402	2170~2500

Capacitor Selection Table

Part	Serial	Typical(pF)	MFR	Size
C1	GRM155	1000	Murata	0402

Pin Configuration and Top Mark

AW15195DNR
(Top View)

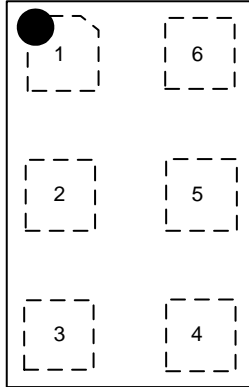

AW15195DNR Marking
(Top View)

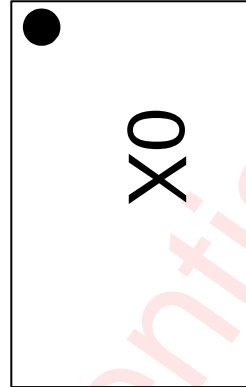

0 - AW15195DNR

X - Production Tracing Code

Figure 2 Pin Configuration and Top Mark

Pin Definition

No.	NAME	DESCRIPTION
1	GND	Ground
2	V _{CC}	Power supply
3	RFOUT	RF output
4	GND	Ground
5	RFIN	RF input
6	V _{EN}	Logic control

Functional Block Diagram

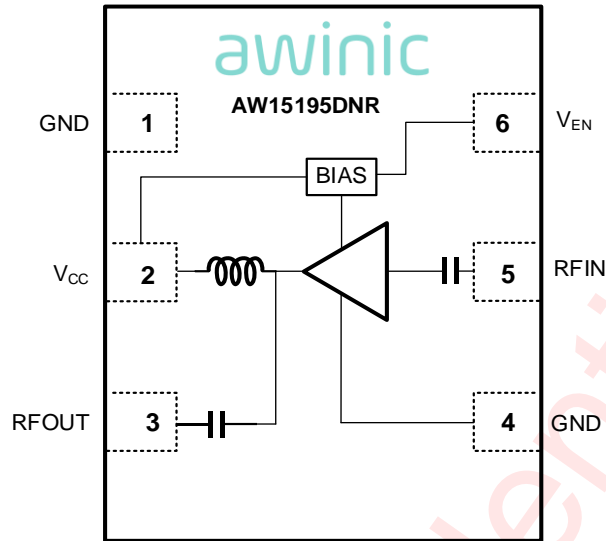

Figure 3 Functional Block Diagram

Ordering Information

Part Number	Temperature	Package	Marking	Moisture Sensitivity Level	Environmental Information	Delivery Form
AW15195DNR	-40°C~105°C	DFN 1.1X0.7-6L	0	MSL1	ROHS+HF	9000 units/Tape & Reel

Absolute Maximum Ratings^[1]

PARAMETERS	RANGE
Supply voltage V_{CC}	-0.3V to 3.6V
Control voltage V_{EN}	-0.3V to V_{CC}
Maximum RF input power	25dBm
Maximum junction temperature T_{JMAX}	150°C
Storage temperature T_{STG}	-65°C to 150°C
Operating free-air temperature range	-40°C to 105°C
Lead temperature (Soldering 10 Seconds)	260°C
HBM ^[2]	±2000V
CDM ^[3]	±1000V

[1] Conditions out of those ranges listed in “absolute maximum ratings” may cause permanent damages to the device. In spite of the limits above, functional operation conditions of the device should within the ranges listed in “recommended operating conditions”. Exposure to absolute-maximum-rated conditions for prolonged periods may affect device reliability.

[2] ESDA/JEDEC JS-001-2024.

[3] ESDA/JEDEC JS-002-2025.

Electrical Characteristics

Common Characteristics

SYMBOL	PARAMETER	TEST CONDITION	MIN	TYP	MAX	UNIT
V _{CC}	Supply voltage	-	1.6	1.8/2.8	3.1	V
I _{CC}	Supply current	V _{EN} =V _{EN_H}	-	14	20	mA
		V _{EN} =V _{EN_L}	-	-	5	μA
V _{EN_H}	Control voltage high	-	0.96	-	V _{CC}	V
V _{EN_L}	Control voltage low	-	0	-	0.3	V
I _{EN}	Leakage current	-	-	1.5	5	μA
T _{ON} ^[1]	Turn-on time	50% V _{EN} to 90% of RF Output	-	0.5	3	μs
T _{OFF} ^[1]	Turn-off time	50% V _{EN} to 10% of RF Output	-	0.1	1.5	μs
K ^[1]	Stability	20MHz~10GHz	>1	-	-	-

[1] Minimum and/or maximum limit is guaranteed by design and by statistical analysis of device characterization data. The specification is not guaranteed by production testing.

Typically: T_A=+25°C, V_{CC}=2.8V, V_{EN}=1.8V, frequency=1518MHz to 1559MHz. Input matched to 50Ω using 6.9nH. (unless otherwise noted).

SYMBOL	PARAMETER	TEST CONDITION	MIN	TYP	MAX	UNIT
G _P	Power gain	PIN=-30dBm	21.5	23	24.5	dB
RL _{in}	Input return loss		8	10	-	dB
RL _{out}	Output return loss		10	12.5	-	dB
ISL	Reverse isolation	-	28	33	-	dB
NF ^{[1] [2]}	Noise figure	No jammer	-	0.55	0.8	dB
OP1dB ^[1]	Output 1dB-compression point	-	5	8.5	-	dBm
OIP3ib ^[1]	Output 3 rd -order intercept point	f1=1520MHz@-25dBm, f2=1521MHZ@-25dBm	15	19	-	dBm

[1] Minimum and/or maximum limit is guaranteed by design and by statistical analysis of device characterization data. The specification is not guaranteed by production testing.

[2] PCB losses are subtracted.

Typically: T_A=+25°C, V_{CC}=2.8V, V_{EN}=1.8V, frequency=2170MHz to 2200MHz. Input matched to 50Ω using 3.5nH. (unless otherwise noted).

SYMBOL	PARAMETER	TEST CONDITION	MIN	TYP	MAX	UNIT
G _P	Power gain	PIN=-30dBm	19	20.5	22	dB
RL _{in}	Input return loss		8	10	-	dB
RL _{out}	Output return loss		10	12.5	-	dB
ISL	Reverse isolation	-	26	30	-	dB
NF ^{[1] [2]}	Noise figure	No jammer	-	0.55	0.8	dB
OP1dB ^[1]	Output 1dB-compression point	-	5	8.5	-	dBm
OIP3ib ^[1]	Output 3 rd -order intercept point	f1=2185MHz@-25dBm, f2=2186MHZ@-25dBm	16	20	-	dBm

[1] Minimum and/or maximum limit is guaranteed by design and by statistical analysis of device characterization data. The specification is not guaranteed by production testing.

[2] PCB losses are subtracted.

Typically: $T_A=+25^{\circ}\text{C}$, $V_{CC}=2.8\text{V}$, $V_{EN}=1.8\text{V}$, frequency=2483.5MHz to 2500MHz. Input matched to 50Ω using 3.5nH. (unless otherwise noted).

SYMBOL	PARAMETER	TEST CONDITION	MIN	TYP	MAX	UNIT
G_P	Power gain	PIN=-30dBm	17.5	19	20.5	dB
RL_in	Input return loss		6	10	-	dB
RL_out	Output return loss		9	11.5	-	dB
ISL	Reverse isolation	-	26	30	-	dB
NF ^[1] [2]	Noise figure	No jammer	-	0.65	1	dB
OP1dB ^[1]	Output 1dB-compression point	-	4	8	-	dBm
OIP3ib ^[1]	Output 3 rd -order intercept point	f1=2492MHz@-25dBm, f2=2493MHZ@-25dBm	15	19	-	dBm

[1] Minimum and/or maximum limit is guaranteed by design and by statistical analysis of device characterization data. The specification is not guaranteed by production testing.

[2] PCB losses are subtracted.

Typically: $T_A=+25^{\circ}\text{C}$, $V_{CC}=1.8\text{V}$, $V_{EN}=1.8\text{V}$, frequency=2483.5MHz to 2500MHz. Input matched to 50Ω using 3.5nH. (unless otherwise noted).

SYMBOL	PARAMETER	TEST CONDITION	MIN	TYP	MAX	UNIT
G_P	Power gain	PIN=-30dBm	17	18.5	20	dB
RL_in	Input return loss		7	9.5	-	dB
RL_out	Output return loss		9	11.5	-	dB
ISL	Reverse isolation	-	25	29	-	dB
NF ^[1] [2]	Noise figure	No jammer	-	0.65	1	dB
OP1dB ^[1]	Output 1dB-compression point	-	2	6	-	dBm
OIP3ib ^[1]	Output 3 rd -order intercept point	f1=2492MHz@-25dBm, f2=2493MHZ@-25dBm	13	17	-	dBm

[1] Minimum and/or maximum limit is guaranteed by design and by statistical analysis of device characterization data. The specification is not guaranteed by production testing.

[2] PCB losses are subtracted.

Package Description

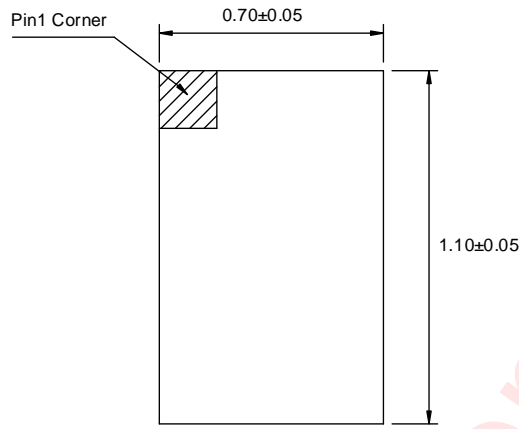

Top View

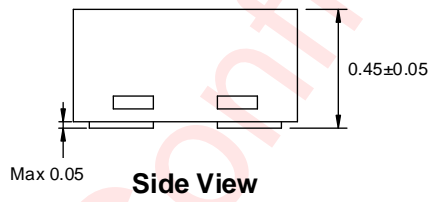

Side View

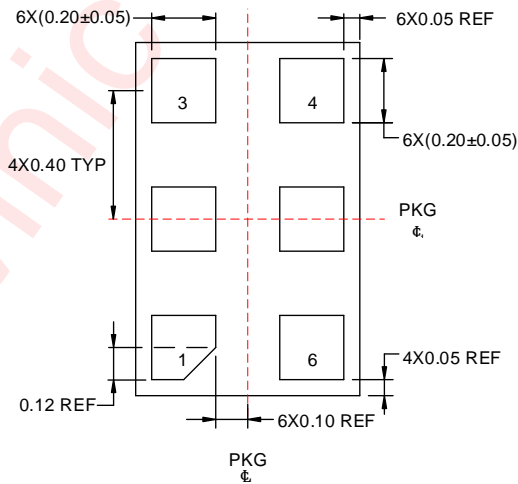

Bottom View

Unit: mm

Figure 4 Package Outline

Land Pattern Data

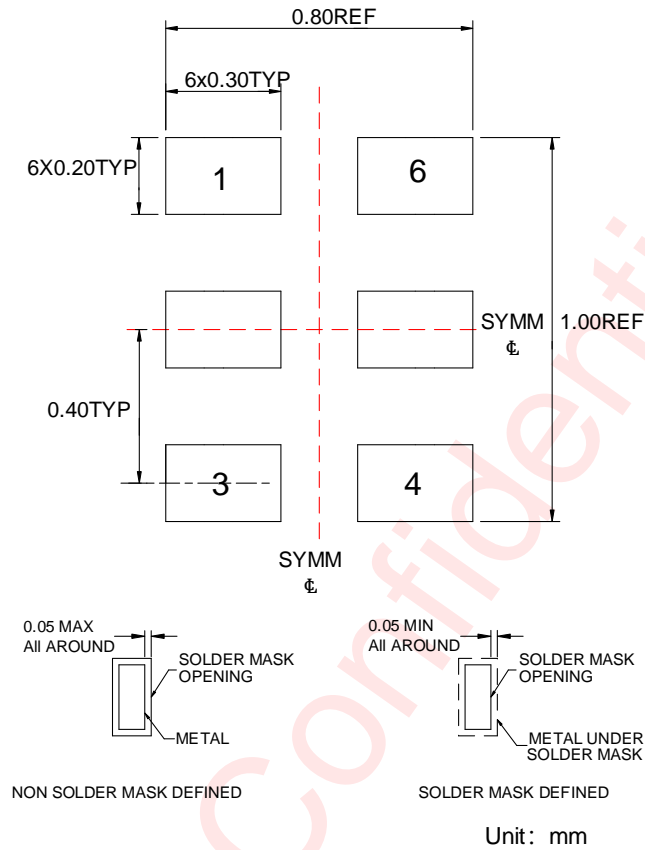
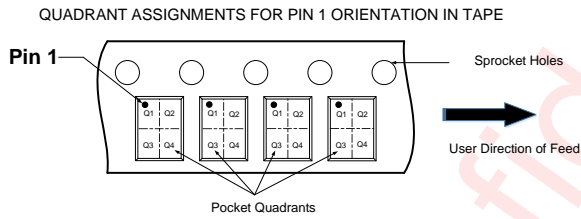
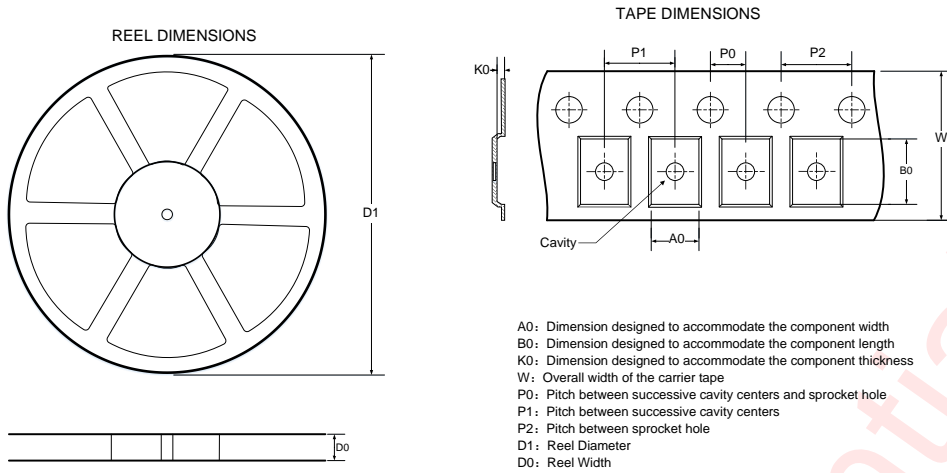

Figure 5 Land Pattern

Tape And Reel Information



Note: The above picture is for reference only. Please refer to the value in the table below for the actual size

DIMENSIONS AND PIN1 ORIENTATION

D1 (mm)	D0 (mm)	A0 (mm)	B0 (mm)	K0 (mm)	P0 (mm)	P1 (mm)	P2 (mm)	W (mm)	Pin1 Quadrant
178	9.5	0.8	1.2	0.55	2	2	4	8	Q1

All dimensions are nominal

Figure 6 Tape & Reel Description

Revision History

Version	Date	Change Record
V1.0	Oct 2025	Officially Released

Awinic Confidential

Disclaimer

All trademarks are the property of their respective owners. Information in this document is believed to be accurate and reliable. However, Shanghai AWINIC Technology Co., Ltd (AWINIC Technology) does not give any representations or warranties, expressed or implied, as to the accuracy or completeness of such information and shall have no liability for the consequences of use of such information.

AWINIC Technology reserves the right to make changes to information published in this document, including without limitation specifications and product descriptions, at any time and without notice. Customers shall obtain the latest relevant information before placing orders and shall verify that such information is current and complete. This document supersedes and replaces all information supplied prior to the publication hereof.

AWINIC Technology products are not designed, authorized or warranted to be suitable for use in medical, military, aircraft, space or life support equipment, nor in applications where failure or malfunction of an AWINIC Technology product can reasonably be expected to result in personal injury, death or severe property or environmental damage. AWINIC Technology accepts no liability for inclusion and/or use of AWINIC Technology products in such equipment or applications and therefore such inclusion and/or use is at the customer's own risk.

Applications that are described herein for any of these products are for illustrative purposes only. AWINIC Technology makes no representation or warranty that such applications will be suitable for the specified use without further testing or modification.

All products are sold subject to the general terms and conditions of commercial sale supplied at the time of order acknowledgement.

Nothing in this document may be interpreted or construed as an offer to sell products that is open for acceptance or the grant, conveyance or implication of any license under any copyrights, patents or other industrial or intellectual property rights.

Reproduction of AWINIC information in AWINIC data books or data sheets is permissible only if reproduction is without alteration and is accompanied by all associated warranties, conditions, limitations, and notices. AWINIC is not responsible or liable for such altered documentation. Information of third parties may be subject to additional restrictions.

Resale of AWINIC components or services with statements different from or beyond the parameters stated by AWINIC for that component or service voids all express and any implied warranties for the associated AWINIC component or service and is an unfair and deceptive business practice. AWINIC is not responsible or liable for any such statements.