

## 4-Bit Bidirectional Voltage-Level Translator with Auto Direction Sensing

### Features

- Voltage level translator without direction control signal
- Wide  $V_{CCA}, V_{CCB}$  operating range: 1.1V to 5V
- $V_{CCA}$  and  $V_{CCB}$  are independent:  $V_{CCA}$  may be greater than, equal to, or less than  $V_{CCB}$
- 100 pF capacitance drive capability
- 140 Mbps data rate for  $V_{CCA}$  and  $V_{CCB} > 1.8$  V
- VCC isolation feature – If either VCC input is at GND, all outputs are in High-Impedance state
- OE input circuit referenced to  $V_{CCA}$
- QFN 2.0mm×1.7mm×0.5mm-12L package

### Applications

Portable Equipment  
UART  
GPIO

### General Description

AW39204GQNR is a 4-bit non-inverting bidirectional voltage-level translator, it can be used to convert digital signal with mixed-voltage systems. It needs two separate power supply rails, with the A ports supporting operating voltages from 1.1 V to 5 V while it tracks the  $V_{CCA}$  supply, and the B ports supporting operating voltages from 1.1 V to 5 V while it tracks the  $V_{CCB}$  supply. This allows the support of both lower and higher logic signal levels while providing bidirectional translation capabilities between any of the 1.2 V, 1.8 V, 2.5 V, 3.3 V, and 5 V voltage nodes.

If the voltage level of output-enable (OE) pin is low, the chip works in the high-impedance state, which significantly reduces the power-supply quiescent current consumption. And the OE input circuit is supplied by  $V_{CCA}$ .

To ensure the high-impedance state during power up or power down, OE should be tied to GND through a pull-down resistor; the minimum value of the resistor is determined by the current-sourcing capability of the driver.

### Typical Application Circuit

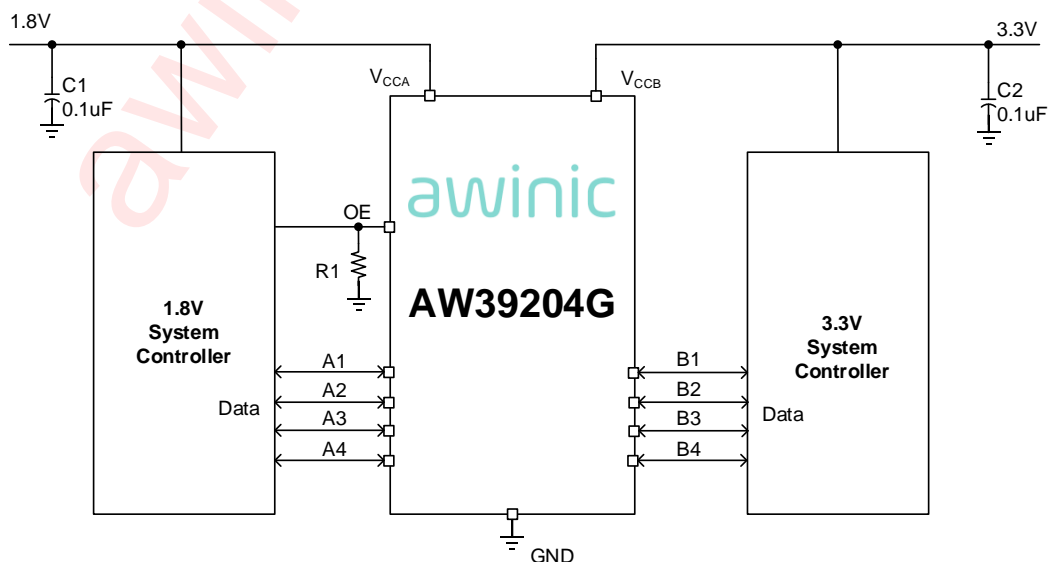

Pin Configuration and Top Mark

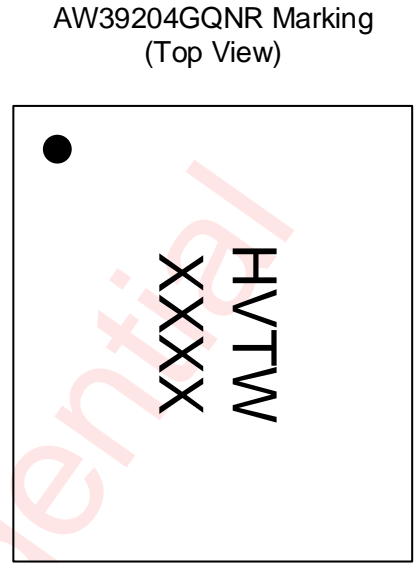
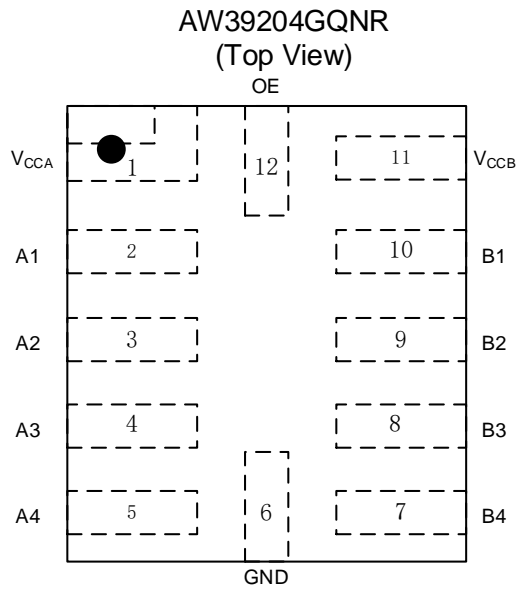

HVTW – AW39204GQNR  
XXXX - Production Tracing Code

awinic Confidential

## Pin Definition

| No. | NAME             | DESCRIPTION  |
|-----|------------------|--|
| 11  | V <sub>CCB</sub> | B-port supply voltage  |
| 1   | V <sub>CCA</sub> | A-port supply voltage  |
| 2   | A1               | Input/output 1. Referenced to V <sub>CCA</sub>   |
| 3   | A2               | Input/output 2. Referenced to V <sub>CCA</sub>   |
| 4   | A3               | Input/output 3. Referenced to V <sub>CCA</sub>   |
| 5   | A4               | Input/output 4. Referenced to V <sub>CCA</sub>   |
| 6   | GND              | Ground   |
| 12  | OE               | 3-state output-mode enable. Pull OE low to place all outputs in 3-state mode. Referenced to V <sub>CCA</sub> . |
| 7   | B4               | Input/output 4. Referenced to V <sub>CCB</sub>   |
| 8   | B3               | Input/output 3. Referenced to V <sub>CCB</sub>   |
| 9   | B2               | Input/output 2. Referenced to V <sub>CCB</sub>   |
| 10  | B1               | Input/output 1. Referenced to V <sub>CCB</sub>   |

Functional Block Diagram

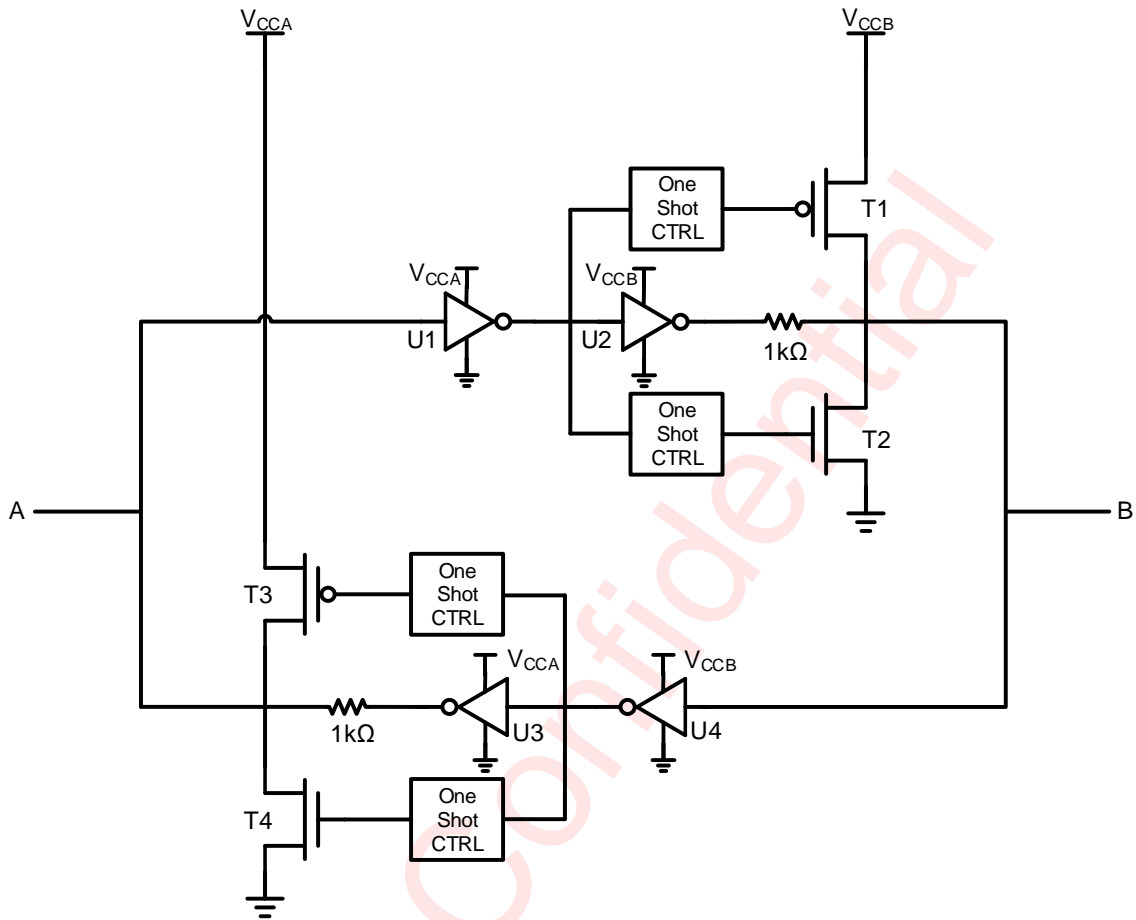

## Typical Application Circuits

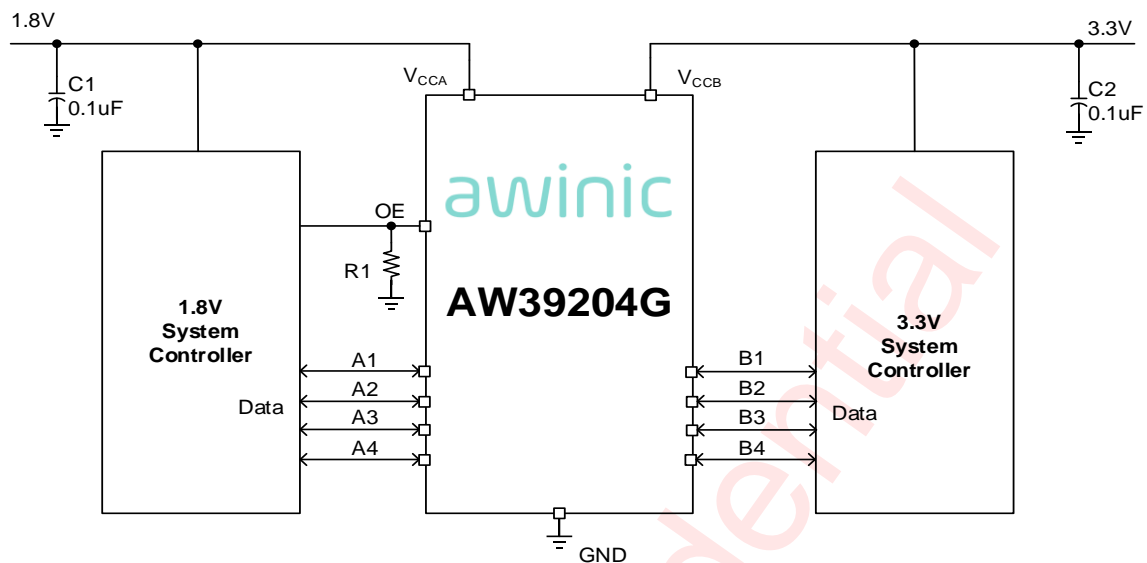

AW39204GQNR Application Circuit

● **Notice for typical application circuits:**

1. Capacitance of C1 and C2 should be 0.1 $\mu$ F or more.
2. Resistance of R1 should be 100k $\Omega$  or more for current consumption.
3. The device driving the data I/Os of the AW39204GQNR must have the drive strength of at least  $\pm 3$  mA.
4. Pull-up resistors are not required on both sides for Logic I/O.
5. If pull-up or pull-down resistors are needed, the resistor value must be over 20 k $\Omega$ .
6. The AW39204GQNR should not be used in applications such as I2C or 1-Wire, please refer to the AW39104 or contact Awinic.
7. The output ports are disabled when either power supply is off ( $V_{CCA}$  or  $V_{CCB} = 0$  V). This feature causes all of the I/O pins to be in the power saving high impedance state.

## Ordering Information

| Part Number | Temperature                       | Package                       | Marking | Moisture Sensitivity Level | Environmental Information | Delivery Form                |
|-------------|-----------------------------------|-------------------------------|---------|----------------------------|---------------------------|------------------------------|
| AW39204GQNR | -40 $^{\circ}$ C~105 $^{\circ}$ C | QFN 2.0mm x 1.7mm x 0.5mm-12L | HVTW    | MSL1                       | ROHS+HF                   | 3000 units/<br>Tape and Reel |

**Absolute Maximum Ratings**<sup>(NOTE1)</sup>

| PARAMETERS  |                  | RANGE                     |
|---|------------------|---------------------------|
| Supply voltage  | V <sub>CCA</sub> | -0.3 to 6V                |
|   | V <sub>CCB</sub> | -0.3 to 6V                |
| V <sub>I</sub> Input voltage  | A port           | -0.3 to 6V                |
|   | B port           | -0.3 to 6V                |
| V <sub>O</sub> Output voltage range in high or low state                | A port           | -0.3 to 6V                |
|   | B port           | -0.3 to 6V                |
| Junction-to-ambient thermal resistance $\theta_{JA}$ <sup>(NOTE2)</sup> |                  | 120°C /W                  |
| Operating free-air temperature range                                    |                  | -40°C -105°C              |
| Maximum operating junction temperature T <sub>JMAX</sub>                |                  | 150°C                     |
| Storage temperature T <sub>STG</sub>                                    |                  | -65°C -150°C              |
| Lead temperature (soldering 10 seconds)                                 |                  | 260°C                     |
| ESD   |                  |                           |
| HBM <sup>(NOTE3)</sup>  |                  | ±6kV                      |
| CDM <sup>(NOTE4)</sup>  |                  | ±1.5kV                    |
| Latch-Up  |                  |                           |
| Test condition <sup>(NOTE5)</sup>                                       |                  | +IT: 200mA<br>-IT: -200mA |

**NOTE1:** Conditions out of those ranges listed in "absolute maximum ratings" may cause permanent damages to the device. In spite of the limits above, functional operation conditions of the device should within the ranges listed in "recommended operating conditions". Exposure to absolute-maximum-rated conditions for prolonged periods may affect device reliability.

**NOTE2:** Thermal resistance from junction to ambient is highly dependent on PCB layout.

**NOTE3:** All pins. Test Condition: ANSI/ESDA/JEDEC JS-001 2017.

**NOTE4:** All pins. Test Condition: ESDA/JEDEC JS-002-2018.

**NOTE5:** All pins. Test Condition: JESD78E

**Recommended Operating Conditions**

| SYMBOL              | PARAMETERS  |        | RANGE          |
|---------------------|---|--------|----------------|
| V <sub>CCA</sub>    | Supply voltage  |        | 1.1V to 5V     |
| V <sub>CCB</sub>    |   |        | 1.1V to 5V     |
| V <sub>OE</sub>     | Enable control pin voltage  |        | 0V to 5V       |
| V <sub>IO</sub>     | Input/Output voltage  | A-port | 0V to 5V       |
|                     |   | B-port | 0V to 5V       |
| T <sub>A</sub>      | Operating free-air temperature  |        | -40°C to 105°C |
| $\Delta t/\Delta V$ | Input transition rise or fall rate<br>V <sub>I</sub> , V <sub>IO</sub> from 30% to 70% of V <sub>CC</sub> ; V <sub>CC</sub> = 3.3 V ± 0.3 V |        | 0 to 40ns/V    |

## DC Electrical Characteristics

Over operating free-air temperature range (unless otherwise noted)

| Parameter           |                             | Test Conditions   |                                | V <sub>CCA</sub> (V) | V <sub>CCB</sub> (V) | MIN                  | TYP | MAX                 | UNIT |
|---------------------|-----------------------------|---|--------------------------------|----------------------|----------------------|----------------------|-----|---------------------|------|
| V <sub>IH</sub>     | High-level input voltage    |   | T <sub>A</sub> = 25°C          | 1.2 – 5              | 1.2 – 5              | 0.8×V <sub>CC</sub>  |     |                     | V    |
| V <sub>OEHigh</sub> | OE High-level input voltage |   | T <sub>A</sub> = 25°C          | 1.2 – 5              | 1.2 – 5              | 0.8×V <sub>CCA</sub> |     |                     | V    |
| V <sub>IL</sub>     | Low-level input voltage     |   | T <sub>A</sub> = 25°C          | 1.2 – 5              | 1.2 – 5              |                      |     | 0.2×V <sub>CC</sub> | V    |
| V <sub>OELow</sub>  | OE Low-level input voltage  |   | T <sub>A</sub> = 25°C          | 1.2 – 5              | 1.2 – 5              |                      |     | 0.2×V <sub>CC</sub> | V    |
| V <sub>OHA</sub>    | High-level output voltage   | I <sub>OH</sub> =-20μA  | T <sub>A</sub> = 25°C          | 1.2 – 5              |                      | 0.9×V <sub>CCA</sub> |     |                     | V    |
| V <sub>OLA</sub>    | Low-level output voltage    | I <sub>OL</sub> =20μA   | T <sub>A</sub> =-40°C-105°C    | 1.2 – 5              |                      |                      |     | 0.2                 | V    |
| V <sub>OHB</sub>    | High-level output voltage   | I <sub>OH</sub> =-20μA  | T <sub>A</sub> = 25°C          |                      | 1.2 – 5              | 0.9×V <sub>CC</sub>  |     |                     | V    |
| V <sub>OLB</sub>    | Low-level output voltage    | I <sub>OL</sub> =20μA   | T <sub>A</sub> = -40°C - 105°C |                      | 1.2 – 5              |                      |     | 0.2                 | V    |
| I <sub>I</sub>      | OE Pin Input Current        | V <sub>I</sub> = V <sub>CC</sub> or GND                               | T <sub>A</sub> = 25°C          | 1.2 – 5              | 1.2 – 5              |                      |     | ±1                  | μA   |
|                     |                             |   | T <sub>A</sub> = -40°C - 105°C | 1.2 – 5              | 1.2 – 5              |                      |     | ±2                  | μA   |
| I <sub>OFF</sub>    | A-port                      | V <sub>I</sub> or V <sub>O</sub> = 0 to 4.5 V                         | T <sub>A</sub> = 25°C          | 0                    | 1.2 – 5              |                      |     | ±1                  | μA   |
|                     |                             |   | T <sub>A</sub> = -40°C - 105°C |                      |                      |                      |     | ±2                  | μA   |
|                     | B-port                      |   | T <sub>A</sub> = 25°C          | 1.2 – 5              | 0                    |                      |     | ±1                  | μA   |
|                     |                             |   | T <sub>A</sub> = -40°C - 105°C |                      |                      |                      |     | ±2                  | μA   |
| I <sub>OZ</sub>     | A or B port                 | OE = GND  | T <sub>A</sub> = 25°C          | 1.2 – 5              | 1.2 – 5              |                      |     | ±1                  | μA   |
|                     |                             |   | T <sub>A</sub> = -40°C - 105°C | 1.2 – 5              | 1.2 – 5              |                      |     | ±2                  | μA   |
| I <sub>CCA</sub>    |                             | V <sub>I</sub> = V <sub>CC</sub> or GND, I <sub>O</sub> = 0           | T <sub>A</sub> = 25°C          | 1.2 – 5              | 1.2 – 5              |                      |     | 3                   | μA   |
|                     |                             |   | T <sub>A</sub> = -40°C - 105°C | 1.2 – 5              | 1.2 – 5              |                      |     | 5                   | μA   |
| I <sub>CCB</sub>    |                             | V <sub>I</sub> = V <sub>CC</sub> or GND, I <sub>O</sub> = 0           | T <sub>A</sub> = 25°C          | 1.2 – 5              | 1.2 – 5              |                      |     | 3                   | μA   |
|                     |                             |   | T <sub>A</sub> = -40°C - 105°C | 1.2 – 5              | 1.2 – 5              |                      |     | 5                   | μA   |
| I <sub>CCZA</sub>   | High-Z state supply current | V <sub>I</sub> = V <sub>CC</sub> or GND, I <sub>O</sub> = 0, OE = GND | T <sub>A</sub> = 25°C          | 1.2 – 5              | 1.2 – 5              |                      |     | 3                   | μA   |
|                     |                             |   | T <sub>A</sub> = -40°C - 105°C | 1.2 – 5              | 1.2 – 5              |                      |     | 5                   | μA   |
| I <sub>CCZB</sub>   | High-Z state supply current | V <sub>I</sub> = V <sub>CC</sub> or GND, I <sub>O</sub> = 0, OE = GND | T <sub>A</sub> = 25°C          | 1.2 – 5              | 1.2 – 5              |                      |     | 3                   | μA   |
|                     |                             |   | T <sub>A</sub> = -40°C - 105°C | 1.2 – 5              | 1.2 – 5              |                      |     | 5                   | μA   |

## Timing Requirements

Over operating free-air temperature range (unless otherwise noted)

| PARAMETER | LOAD                  | V <sub>CCA</sub> (V) | V <sub>CCB</sub> (V) | MIN | MAX | UNIT |
|-----------|-----------------------|----------------------|----------------------|-----|-----|------|
| Data rate | C <sub>L</sub> =15pF  | 1.2-5                | 1.2-5                |     | 50  | Mbps |
|           | C <sub>L</sub> =15pF  | 1.8-5                | 1.8-5                |     | 140 | Mbps |
|           | C <sub>L</sub> =30pF  | 1.2-5                | 1.2-5                |     | 40  | Mbps |
|           | C <sub>L</sub> =30pF  | 1.8-5                | 1.8-5                |     | 120 | Mbps |
|           | C <sub>L</sub> =50pF  | 1.2-5                | 1.2-5                |     | 30  | Mbps |
|           | C <sub>L</sub> =50pF  | 1.8-5                | 1.8-5                |     | 100 | Mbps |
|           | C <sub>L</sub> =100pF | 1.2-5                | 1.2-5                |     | 20  | Mbps |
|           | C <sub>L</sub> =100pF | 1.8-5                | 1.8-5                |     | 60  | Mbps |

## Switching Characteristics

Over operating free-air temperature range (unless otherwise noted)

| PARAMETER                         | FROM (INPUT)               | TO (OUTPUT) | LOAD                  | V <sub>CCA</sub> (V) | V <sub>CCB</sub> (V) | MIN | TYP | MAX | UNIT |
|-----------------------------------|----------------------------|-------------|-----------------------|----------------------|----------------------|-----|-----|-----|------|
| T <sub>PD</sub>                   | A                          | B           | C <sub>L</sub> =15pF  | 1.2-5                | 1.2-5                |     | 18  | 35  | ns   |
|                                   |                            |             | C <sub>L</sub> =15pF  | 1.8-5                | 1.8-5                |     | 9   | 18  |      |
|                                   |                            |             | C <sub>L</sub> =30pF  | 1.2-5                | 1.2-5                |     | 18  | 35  |      |
|                                   |                            |             | C <sub>L</sub> =30pF  | 1.8-5                | 1.8-5                |     | 8   | 18  |      |
|                                   |                            |             | C <sub>L</sub> =50pF  | 1.2-5                | 1.2-5                |     | 19  | 35  |      |
|                                   |                            |             | C <sub>L</sub> =50pF  | 1.8-5                | 1.8-5                |     | 9   | 18  |      |
|                                   |                            |             | C <sub>L</sub> =100pF | 1.2-5                | 1.2-5                |     | 20  | 35  |      |
|                                   |                            |             | C <sub>L</sub> =100pF | 1.8-5                | 1.8-5                |     | 10  | 18  |      |
|                                   | B                          | A           | C <sub>L</sub> =15pF  | 1.2-5                | 1.2-5                |     | 18  | 35  | ns   |
|                                   |                            |             | C <sub>L</sub> =15pF  | 1.8-5                | 1.8-5                |     | 9   | 18  |      |
|                                   |                            |             | C <sub>L</sub> =30pF  | 1.2-5                | 1.2-5                |     | 18  | 35  |      |
|                                   |                            |             | C <sub>L</sub> =30pF  | 1.8-5                | 1.8-5                |     | 9   | 18  |      |
|                                   |                            |             | C <sub>L</sub> =50pF  | 1.2-5                | 1.2-5                |     | 19  | 35  |      |
|                                   |                            |             | C <sub>L</sub> =50pF  | 1.8-5                | 1.8-5                |     | 9   | 18  |      |
| t <sub>en</sub>                   | OE                         | A           | C <sub>L</sub> =15pF  | 1.2-5                | 1.2-5                |     | 50  | 150 | ns   |
|                                   |                            | B           | C <sub>L</sub> =15pF  | 1.8-5                | 1.8-5                |     | 50  | 100 | ns   |
| t <sub>dis</sub>                  | OE                         | A           | C <sub>L</sub> =15pF  | 1.2-5                | 1.2-5                |     | 95  | 200 | ns   |
|                                   |                            | B           | C <sub>L</sub> =15pF  | 1.8-5                | 1.8-5                |     | 95  | 200 | ns   |
| t <sub>rB</sub> , t <sub>fB</sub> | B-port rise and fall times |             | C <sub>L</sub> =15pF  | 1.2-5                | 1.2-5                |     | 1.5 |     | ns   |
| t <sub>rA</sub> , t <sub>fA</sub> | A-port rise and fall times |             | C <sub>L</sub> =15pF  | 1.2-5                | 1.2-5                |     | 1.5 |     | ns   |
| t <sub>sk</sub>                   | Channel-to-channel skew    |             | C <sub>L</sub> =15pF  | 1.2-5                | 1.2-5                |     | 0.5 |     | ns   |

## Typical Characteristics

AW39204GQNR is a 4-bit voltage-level translator without direction control signal, which is suitable for interfacing devices or systems operating at different interface voltages with one another. Port A can supports I/O voltages from 1.1 V to 5 V, while Port B is able to support I/O voltage range from 1.1 V to 5 V.

### Input Driver Requirements

The figure shows the typical  $I_{IN}$  vs  $V_{IN}$  curve. For proper operation, the device driving the data I/Os of the AW39204GQNR must have the drive strength of at least  $\pm 3$  mA.

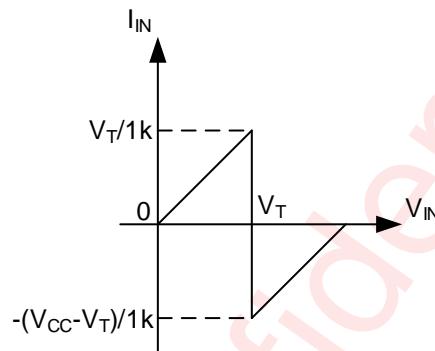

- (1)  $V_{CC}$  is the supply voltage.
- (2)  $V_T$  is the input threshold voltage of AW39204GQNR (typically it is  $V_{CC}/2$ ).

Typical  $I_{IN}$  vs  $V_{IN}$  Curve

### VCC Capacitor Selection

The device is a 4-bit high-performance voltage-level translator that requires adequate power supply decoupling. Place a low equivalent-series-resistance (ESR) ceramic capacitor, recommend 0.1 $\mu$ F or larger than 0.1 $\mu$ F.

### Input Voltage Range

$V_{IH}$  is the lowest valid logic high value of the input port,  $V_{IL}$  is the highest valid logic low value of the input port, so the valid logic high value should exceed  $V_{IH}$ , the valid logic low value should less than  $V_{IL}$ .

### I/O Current

Don't recommend to have the strong current on the I/O pins at the same time. Don't recommend to have the external pull-up or pull-down resistors.

Application Curve

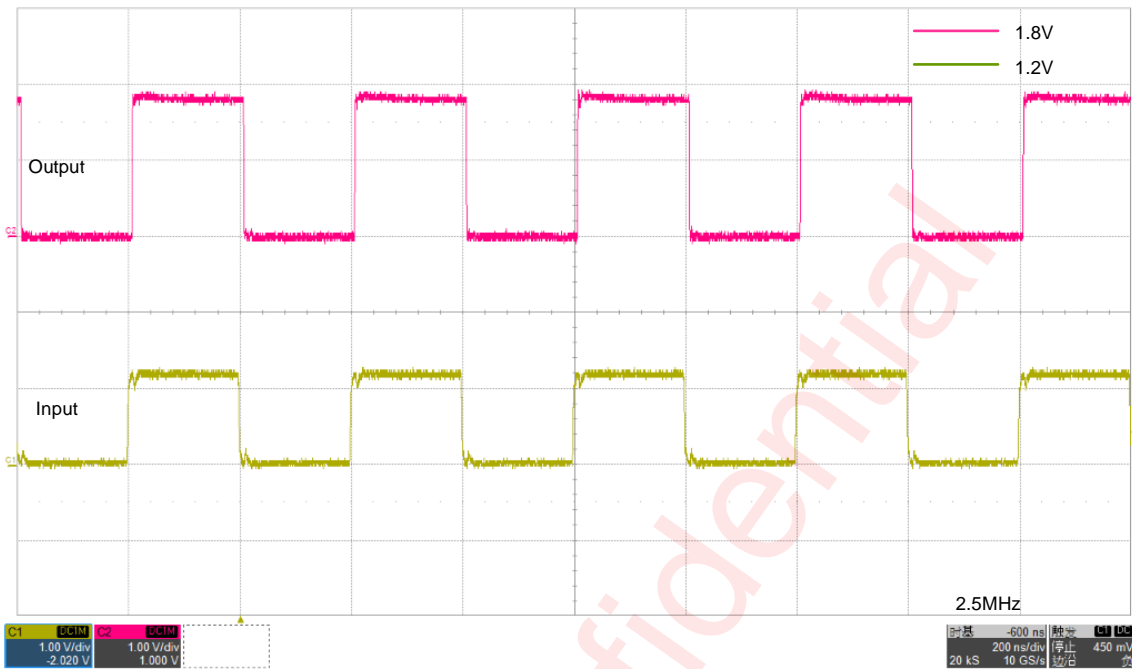

2.5-MHz 1.2V-1.8V Signal Level-Translation @ $C_L=15p$



2.5-MHz 1.2V-1.8V Signal Level-Translation @ $C_L=30p$

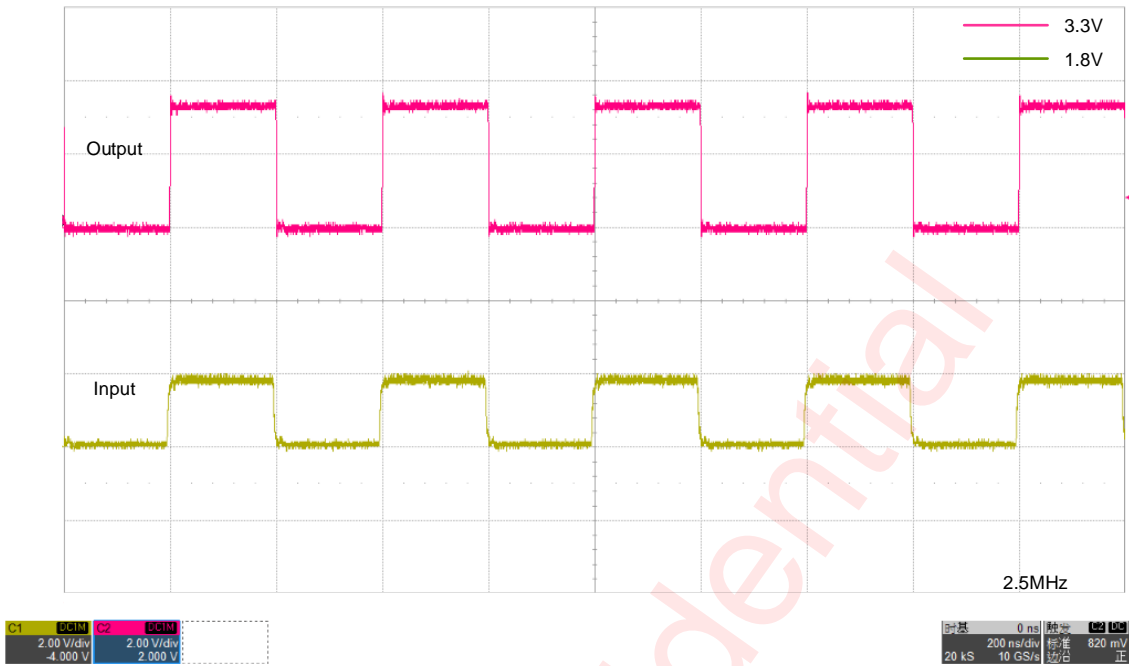

2.5-MHz 1.8V-3.3V Signal Level-Translation @ $C_L=15p$



2.5-MHz 1.8V-3.3V Signal Level-Translation @ $C_L=30p$

## Detailed Functional Description

AW39204GQNR is a 4-bit high-performance voltage-level translator without direction control signal, which is a non-inverting converter and can be used to convert digital signal with mixed-voltage systems. Port A can support I/O voltages from 1.1 V to 5 V, while Port B is able to support I/O voltage range from 1.1 V to 5 V. The chip uses a transmission gate architecture with an rising edge rate accelerator (one-shot), to increase overall data rate.

### One-Shot Accelerator

The One-Shot rising edge accelerator circuit speeds up the rising edge to help increasing the chip's data rate. Once the chip has detected the rising edge of the input signal from low to high, which enables the internal pull-up PMOS transistor between power supply and output, thereby accelerating the output port from low to high. While detecting the output has been turned up, the one-shot pulse signal is finished and pull-up PMOS transistor is quickly turned off. This architecture reduces the average dynamic power consumption of the chip while allowing it to meet different drive requirements.

### Enable and Disable

The AW39204GQNR has an OE input that is used to disable the device by setting OE = low, which places all I/Os in the high-impedance (Hi-Z) state. The disable time ( $t_{dis}$ ) indicates the delay between when OE goes low and when the outputs are actually disabled (Hi-Z). The enable time ( $t_{en}$ ) indicates the amount of time the user must allow for the one-shot circuitry to become operational after OE is taken high.

### Pull-up or Pull-down Resistor on I/O Lines

The AW39204GQNR is designed to drive capacitive loads of up to 100 pF. The output drivers of the AW39204GQNR have low dc drive strength. If pull-up or pull-down resistors are connected externally to the data I/Os, their values must be kept higher than 20 kΩ to ensure that they do not contend with the output drivers of the AW39204GQNR. But if the receiver is integrated with the smaller pull down or pull up resistor, below formula can be used for estimation to evaluate the  $V_{OH}$  and  $V_{OL}$ .

$$V_{OL} = V_{CCout} * \frac{1.5k\Omega}{1.5k\Omega + R_{pu}}$$

$$V_{OH} = V_{CCout} * \frac{R_{pd}}{1.5k\Omega + R_{pd}}$$

where

- $V_{CCout}$  is the output port supply voltage on either  $V_{CCA}$  or  $V_{CCB}$
- $R_{pd}$  is the value of the external pull down resistor
- $R_{pu}$  is the value of the external pull up resistor
- 1.5 kΩ is the counting the variation of the serial resistor 1kΩ in the I/O line.

Because of this restriction on external resistors, the AW39204GQNR should not be used in applications such as I2C or 1-Wire where an open-drain driver is connected on the bidirectional data I/O. For these applications, use a device from the Awinic AW39104QNR series of level translators.

### Power Up

During operation, AW39204GQNR can work at both  $V_{CCA} \leq V_{CCB}$  and  $V_{CCA} \geq V_{CCB}$ . During power-up sequencing, any power supply can be ramped up first. The AW39204GQNR has circuitry that disables all output ports when either VCC is switched off ( $V_{CCA/B} = 0\text{ V}$ ).

### Power Off Protection

The AW39204GQNR has power protection function. When the chip is powered off but the signal input source on the port is not turned off, the port does not sink current to the chip when there is still signal input.

awinic Confidential

## PCB Layout Consideration

To make full use of the performance of AW39204GQNR, the printed-circuit board layout guidelines below should be followed.

1. C1 and C2 should be placed on the top layer as close as possible to the  $V_{CC(A)}$  and  $V_{CC(B)}$  pin.
2. The trace of signals should be short enough to avoid any reflection when transmitted.
3. For long transmission lines, place a series resistor equivalent to the impedance of the transmission lines to avoid signal integrity issues.

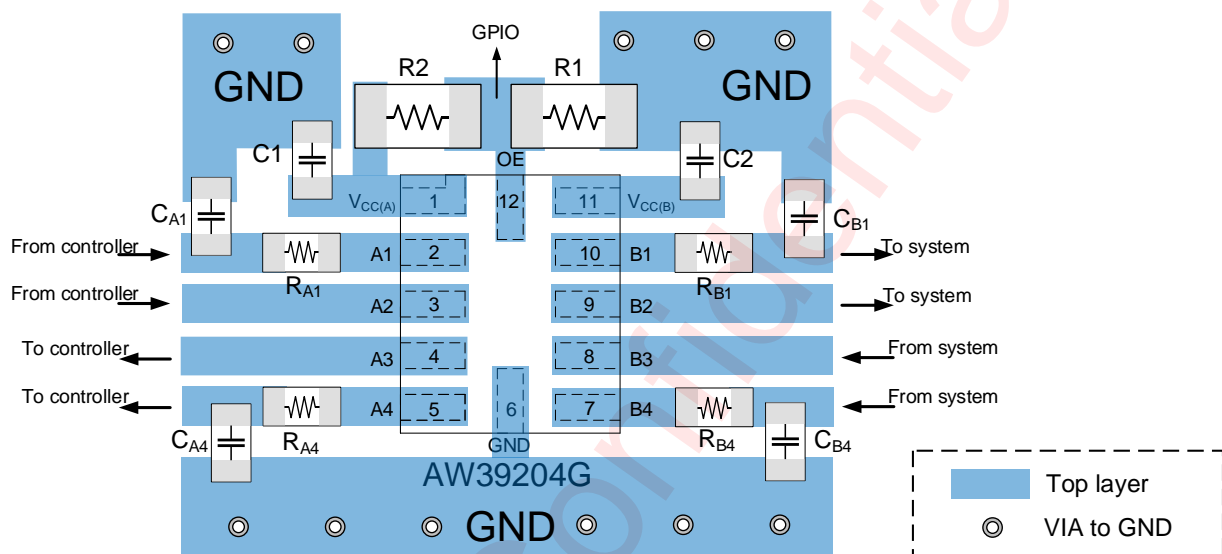

AW39204GQNR PCB Layout

## Tape And Reel Information

### QFN 2.0mmX1.7mm-12L

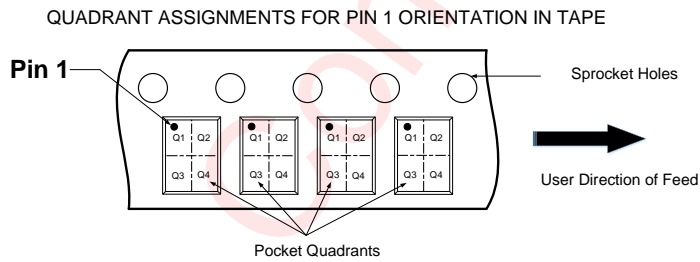
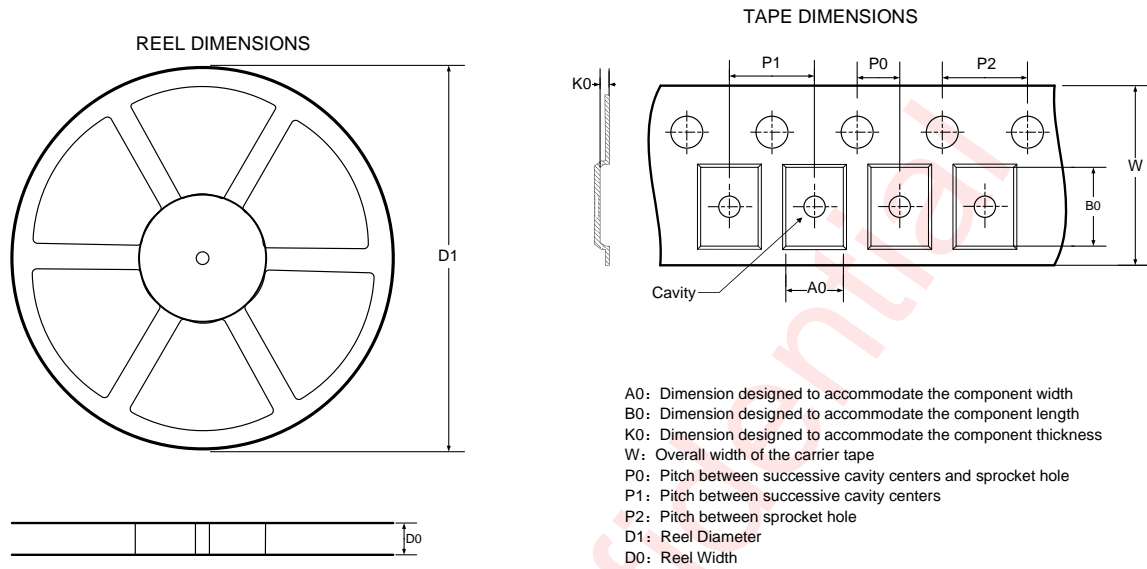

Note: The above picture is for reference only. Please refer to the value in the table below for the actual size

DIMENSIONS AND PIN1 ORIENTATION

| D1 (mm) | D0 (mm) | A0 (mm) | B0 (mm) | K0 (mm) | P0 (mm) | P1 (mm) | P2 (mm) | W (mm) | Pin1 Quadrant |
|---------|---------|---------|---------|---------|---------|---------|---------|--------|---------------|
| 180     | 9.5     | 1.9     | 2.3     | 0.75    | 2       | 4       | 4       | 8      | Q1            |

All dimensions are nominal

Package Description

QFN 2.0mmX1.7mm-12L

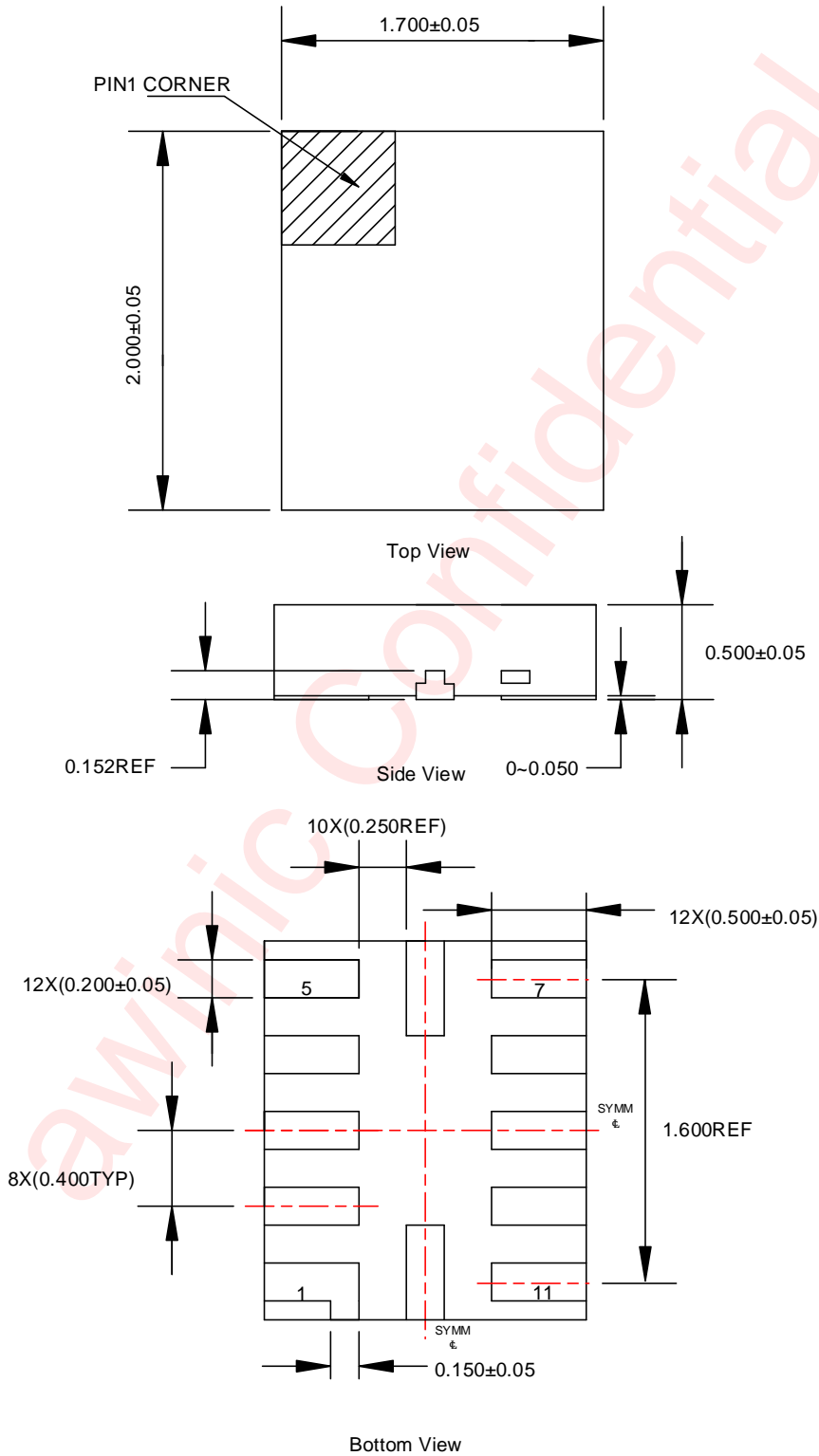

Unit: mm

Land Pattern Data

QFN 2.0mmX1.7mm-12L

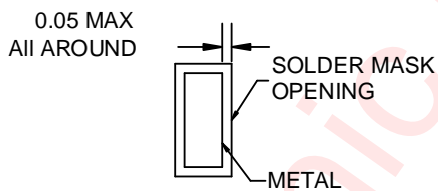
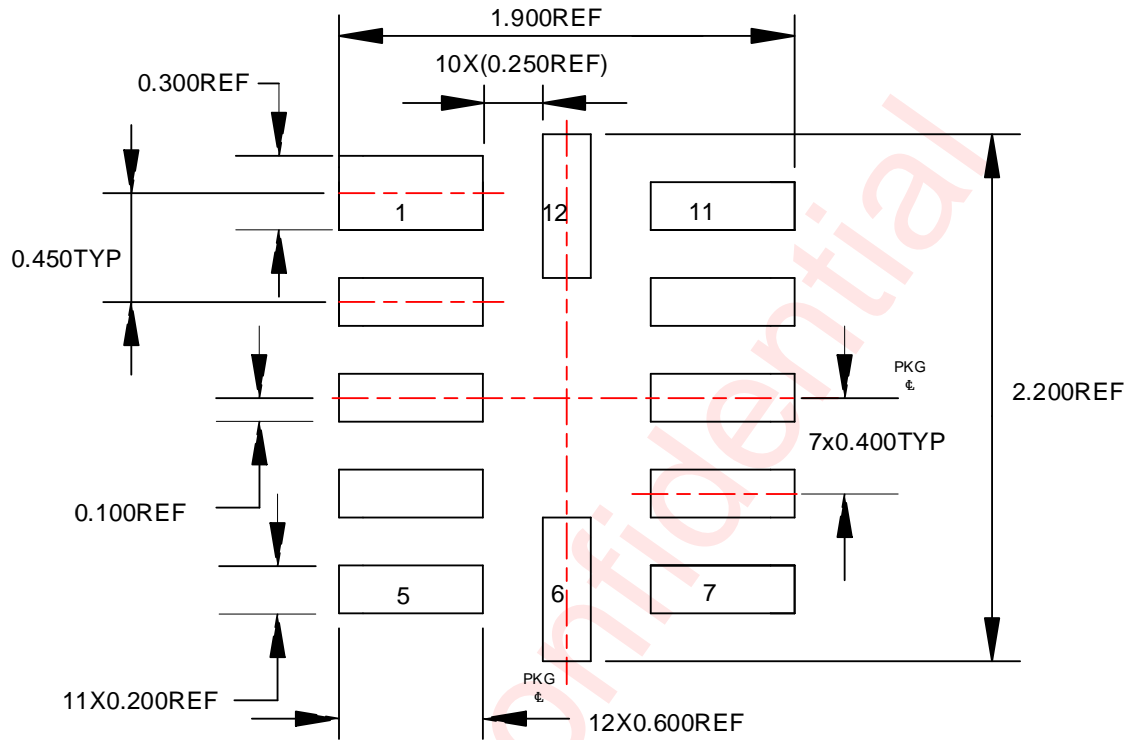

NON SOLDER MASK DEFINED

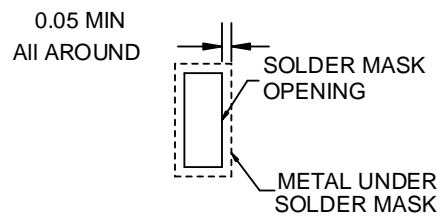

SOLDER MASK DEFINED

Unit: mm

## Revision History

| Version | Date          | Change Record        |
|---------|---------------|----------------------|
| V1.0    | December 2019 | Officially released. |

awinic Confidential

## Disclaimer

All trademarks are the property of their respective owners. Information in this document is believed to be accurate and reliable. However, Shanghai AWINIC Technology Co., Ltd (AWINIC Technology) does not give any representations or warranties, expressed or implied, as to the accuracy or completeness of such information and shall have no liability for the consequences of use of such information.

AWINIC Technology reserves the right to make changes to information published in this document, including without limitation specifications and product descriptions, at any time and without notice. Customers shall obtain the latest relevant information before placing orders and shall verify that such information is current and complete. This document supersedes and replaces all information supplied prior to the publication hereof.

AWINIC Technology products are not designed, authorized or warranted to be suitable for use in medical, military, aircraft, space or life support equipment, nor in applications where failure or malfunction of an AWINIC Technology product can reasonably be expected to result in personal injury, death or severe property or environmental damage. AWINIC Technology accepts no liability for inclusion and/or use of AWINIC Technology products in such equipment or applications and therefore such inclusion and/or use is at the customer's own risk.

Applications that are described herein for any of these products are for illustrative purposes only. AWINIC Technology makes no representation or warranty that such applications will be suitable for the specified use without further testing or modification.

All products are sold subject to the general terms and conditions of commercial sale supplied at the time of order acknowledgement.

Nothing in this document may be interpreted or construed as an offer to sell products that is open for acceptance or the grant, conveyance or implication of any license under any copyrights, patents or other industrial or intellectual property rights.

Reproduction of AWINIC information in AWINIC data books or data sheets is permissible only if reproduction is without alteration and is accompanied by all associated warranties, conditions, limitations, and notices. AWINIC is not responsible or liable for such altered documentation. Information of third parties may be subject to additional restrictions.

Resale of AWINIC components or services with statements different from or beyond the parameters stated by AWINIC for that component or service voids all express and any implied warranties for the associated AWINIC component or service and is an unfair and deceptive business practice. AWINIC is not responsible or liable for any such statements.