

11V Fast Startup With F0 Detect And Tracking LRA Haptic Driver

Features

- 1MHz I2C Bus
- 12-KByte Memory
- 12k/24k/48k input wave sampling rate
- F0 detect and tracking
- Advance autobrake engine integrated
- Playback mode:
 - Real time playback(Up to 4KByte FIFO)
 - Memory playback
 - I2S playback
 - 3 Trigger playback
 - One wire playback
 - Cont playback
- Resistance-Based LRA Diagnostics
- Drive signal monitor for LRA protect
- Drive Compensation Over Battery Discharge
- Fast Start Up Time < 1ms
- Dedicated interrupt output pin
- Boost output voltage up to 11V
- VOUT=8.5V@Vbat=4.2V for 8Ω LRA
- Support automatically switch to standby mode
- Standby current: 8 μ A @Vbat=3.6V
- Shutdown current: 0.1 μ A
- Supply voltage range 3 to 5.5V
- Short-Circuit Protection, Over-Temperature Protection, Under-Voltage Protection
- FCQFN 2mm × 3mm × 0.55mm -20L Package

Applications

- Mobile phones
- Tablets
- Wearable Devices

General Description

AW86917 is a high voltage H-bridge, single chip LRA haptic driver, with F0 detecting and tracking based on BEMF, with a boost converter up to 11V drive voltage inside, supporting real time playback, memory playback, cont playback, I2S playback, one wire and hardware pin triggered playback. A typical startup time of 1ms makes the AW86917 an ideal haptic driver for fast responses.

AW86917 integrates a 12KByte SRAM for user-defined waveforms to achieve a variety of vibration experiences, supporting 3 sampling rate(12k/24k/48k) of waveforms loaded in SRAM, supporting output waveform sampling rate up-sampling to 48k.

AW86917 integrates an autobrake engine to suppress the aftershocks to zero for different drive waveforms(short or long) on different LRA motor.

AW86917 supports LRA fault diagnostic based on resistance measurement and protections of short-circuit, over-temperature and under-voltage.

AW86917 integrates a high-efficiency boost converter as the H-Bridge driver supply rail. The output voltage, maximum current limit and maximum boost current are configurable.

AW86917 features configurable automatically switch to standby mode. This can less quiescent power consumption. Dedicated interrupt output pin can detect real time FIFO status and the error status of the chip.

AW86917 features general settings are communicated via an I2C-bus interface and its I2C address is configurable.

AW86917 is available in a FCQFN 2mm x 3mm x 0.55mm -20L package.

Pin Configuration And Top Mark

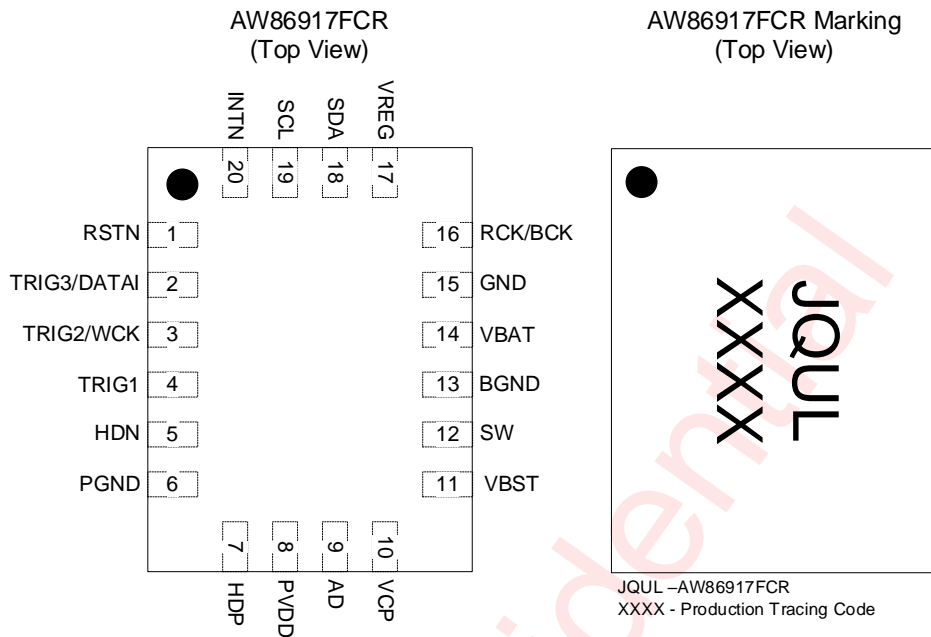

Figure 1 Pin Configuration and Top Mark

Pin Definition

PIN NUMBER	NAME	I/O	DESCRIPTION
1	RSTN	I	Active low hardware reset. High: standby/active mode Low: power-down mode. Internal have 2MΩ pull-down resistor
2	TRIG3/ DATA1	I	Hardware trigger 3 or DATA1 in I2S mode. Internal have 2MΩ pull-down resistor.
3	TRIG2/WCK	I	Hardware trigger 2 or WCK in I2S mode. Internal have 2MΩ pull-down resistor.
4	TRIG1	I	Hardware trigger 1. Internal have 2MΩ pull-down resistor.
5	HDN	O	Negative haptic driver differential output
6	PGND	Ground	H-bridge driver GND
7	HDP	O	Positive haptic driver differential output
8	PVDD	Power	High voltage driver power rail
9	AD	I	I2C bus address selection
10	VCP	O	Internal charge pump voltage
11	VBST	Power	Boost output voltage
12	SW	O	Internal boost switch pin
13	BGND	Ground	Boost GND
14	VBAT	Power	Chip power supply
15	GND	Ground	Supply ground
16	RCK/BCK	I	BCK input in I2S mode or PLL reference CLK input . IIC reg I2SBCK should be configured in 0x4A. Internal have 2MΩ pull-down resistor.
17	VREG	Power	Digital power supply
18	SDA	IO	I2C bus data input/output(open drain)
19	SCL	I	I2C bus clock input
20	INTN	O	Interrupt open drain output, low active.

Functional Block Diagram

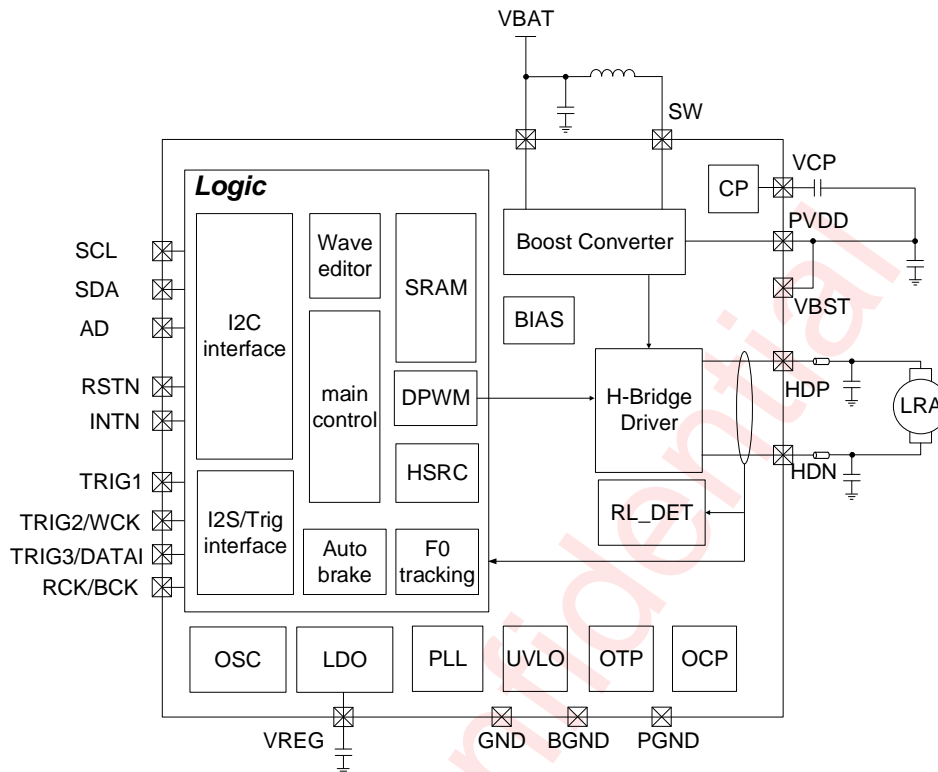

Figure 2 Functional Block Diagram

Typical Application Circuits

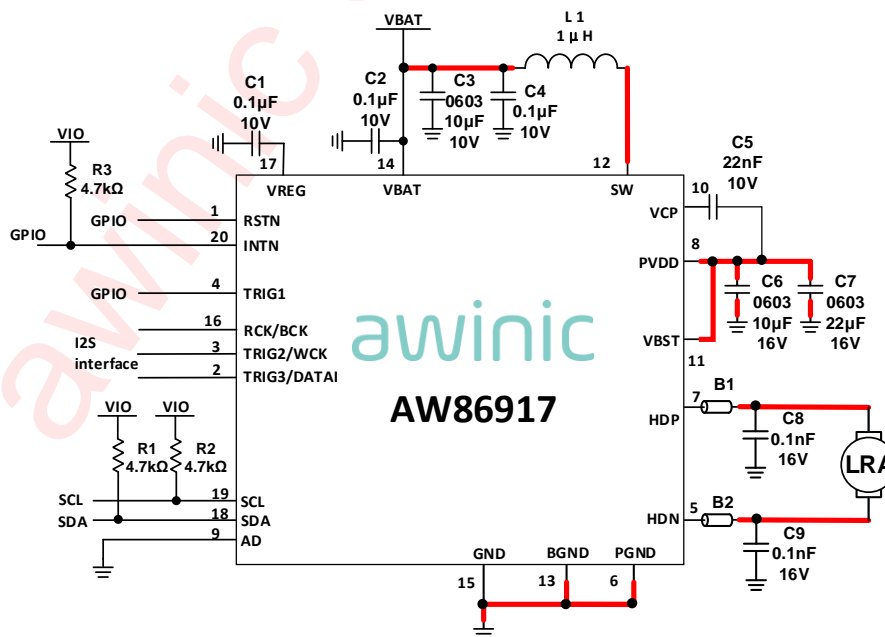

Figure 3 Typical Application Circuit of AW86917

Notice for Typical Application Circuits:

1: Please place C1, C2, C3, C4, C5, C6, C7 as close to the chip as possible, and C6 and C7 close to PIN 11 and the capacitors should be placed in the same layer with the AW86917 chip.

2: For the sake of driving capability, the power lines (especially the one to Pin 12), output lines, and the connection lines of L1, and SW should be short and wide as possible. The power path marked in red as shown in the figures above. Please traces according to 3.5A power line alignment rules, for VBAT to SW through L1. and the other red path traces according to 1.5A power line alignment rules.

Ordering Information

Part Number	Temperature	Package	Marking	Moisture Sensitivity Level	Environment Information	Delivery Form
AW86917FCR	-40°C ~ 85°C	FCQFN 2mmX3mmX0.55mm- 20L	JQUL	MSL1	ROHS+HF	6000 units/ Tape and Reel

Absolute Maximum Ratings(NOTE 1)

Parameter	Range
Battery Supply Voltage VBAT	-0.3V to 6.0V
Digital power supply VREG	-0.3V to 2.0V
Internal charge pump voltage VCP	-0.3V to 17V
Boost output voltage VBST PVDD	-0.3V to 13V
Internal boost switch pin SW	-0.3V to 15V
HDP, HDN	-0.3V to PVDD+0.3V
Package Thermal Resistance θ_{JA}	60°C/W
Ambient Temperature Range	-40°C to 85°C
Maximum Junction Temperature T_{JMAX}	150°C
Storage Temperature Range T_{STG}	-65°C to 150°C
Lead Temperature(Soldering 10 Seconds)	260°C
ESD Rating (NOTE 2 3)	
HBM(Human Body Model)	±2kV
CDM(Charge Device Model)	±1.5kV
Latch-up	
Test Condition: JEDEC EIA/JESD78E	+IT: 200mA -IT: -200mA

NOTE 1: Conditions out of those ranges listed in "absolute maximum ratings" may cause permanent damages to the device. In spite of the limits above, functional operation conditions of the device should within the ranges listed in "recommended operating conditions". Exposure to absolute-maximum-rated conditions for prolonged periods may affect device reliability.

NOTE 2: The human body model is a 100pF capacitor discharged through a 1.5kΩ resistor into each pin. Test method: ANSI/ESDA/JEDEC JS-001-2017.

NOTE 3: Charge Device Model test method: JEDEC EIA/JESD22-C101F.

Electrical Characteristics

Characteristics

Test condition: TA=25°C, VBAT=4.2V, PVDD=8V, RL=8Ω+100μH(unless otherwise noted)

Symbol	Description	Test Conditions	Min	Typ.	Max	Units
V _{BAT}	Battery supply voltage	On pin VBAT	3		5.5	V
V _{VREG}	Voltage at VREG pin			1.8		V
V _{IL}	Logic input low level	RSTN/TRIG1/TRIG2/TRIG3/ AD/ SCLK			0.5	V
V _{IH}	Logic input high level	RSTN/TRIG1/TRIG2/TRIG3/ AD/ SCLK	1.3			V
V _{OL}	Logic output low level	INTN/SDA I _{OUT} =4mA			0.4	V
V _{OS}	Output offset voltage	I2C signal input 0	-30	0	30	mV
I _{SD}	Shutdown current	VBAT=4.2V, RSTN =0V		0.1	1	μA
I _{STBY}	Standby current	VBAT=3.6V, AD= 0V TRIG1=TRIG2=TRIG3=0V RSTN=SCL=SDA=1.8V		8		μA
I _Q	Quiescent current	VBAT=3.6V@Bypass		5		mA
UVP	Under-voltage protection voltage			2.7		V
	Under-voltage protection hysteresis voltage			100		mV
T _{SD}	Over temperature protection threshold			160		°C
T _{SDR}	Over temperature protection recovery threshold			130		°C
T _{on1}	Time from shutdown to standby				6	ms
T _{on2}	Time from standby to active	From trigger to output signal			1	ms
Boost						
OVP	Over-voltage threshold			1.1*V _{PVDD}		
F _{BST}	Operating Frequency			1.6		MHz
I _{L_PEAK}	Inductor peak current limit			4		A
T _{ST}	Soft-start time	No load, C _{OUT} =20μF		0.3		ms
HDRIVER						
R _{dson}	Drain-Source on-state resistance	Include NMOS and PMOS		300		mΩ

Symbol	Description	Test Conditions	Min	Typ.	Max	Units
R_{ocp}	Load impedance threshold for over current protection	VBAT=3.6V, PVDD=8V		2		Ω
F_{PWM}	PWM output frequency	VBAT=4.2V, PD_HWM=0		96		kHz
		VBAT=4.2V, PD_HWM=1		48		kHz
$F_{CALI_ACC_LRA}$	LRA Consistency Calibration accuracy		F0-2	F0	F0+2	Hz
V_{peak}	Output voltage	RL=16 Ω +100 μ H VBAT=4.2V, PVDD set 11V		10.5		V
	Output voltage	RL=8 Ω +100 μ H VBAT=4.2V, PVDD set 11V		8.5		V

awinic Confidential

I2C Interface Timing

Parameter			fast mode			fast mode plus			UNIT
No.	Symbol	Name	MIN	TYP	MAX	MIN	TYP	MAX	
1	f_{SCL}	SCL Clock frequency			400			1000	kHz
2	t_{LOW}	SCL Low level Duration	1.3			0.5			μs
3	t_{HIGH}	SCL High level Duration	0.6			0.26			μs
4	t_{RISE}	SCL, SDA rise time			0.3			0.12	μs
5	t_{FALL}	SCL, SDA fall time			0.3			0.12	μs
6	$t_{SU:STA}$	Setup time SCL to START state	0.6			0.26			μs
7	$t_{HD:STA}$	(Repeat-start) Start condition hold time	0.6			0.26			μs
8	$t_{SU:STO}$	Stop condition setup time	0.6			0.26			μs
9	t_{BUF}	the Bus idle time START state to STOP state	1.3			0.5			μs
10	$t_{SU:DAT}$	SDA setup time	0.1			0.1			μs
11	$t_{HD:DAT}$	SDA hold time	10			10			ns

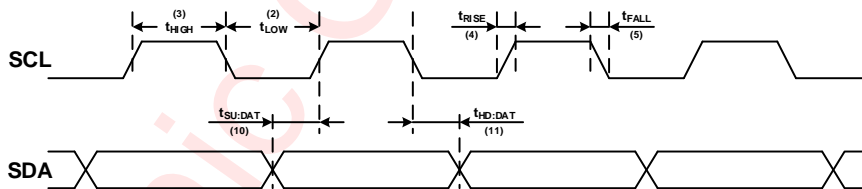

Figure 4 SCL and SDA timing relationships in the data transmission process

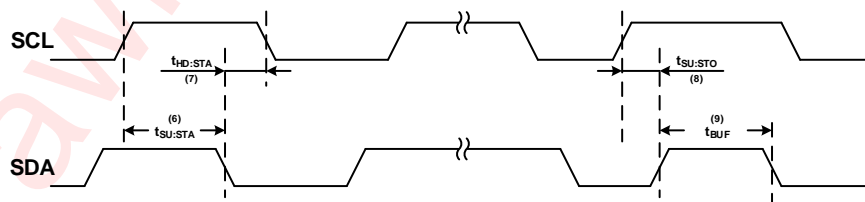

Figure 5 The timing relationship between START and STOP state

Digital Audio Interface Timing

Parameter Name		Min	Typ.	Max	Units
f_s	sampling frequency, on pin WCK		48		kHz
f_{bck}	Bit clock frequency, on pin BCK	$32 \cdot f_s$		$64 \cdot f_s$	Hz
t_{su}	WCK, DATAI Setup time to BCK	10			ns
t_h	WCK, DATAI hold time to BCK	10			ns

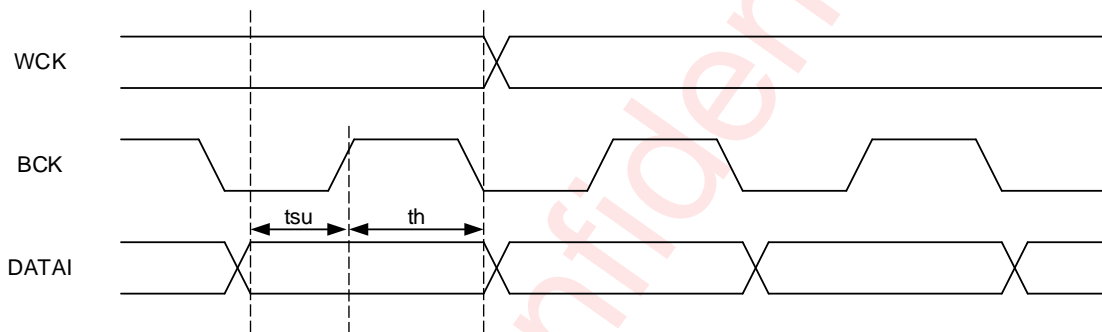

Figure 6 Digital Audio Interface Timing

Measurement Setup

AW86917 features switching digital output, as shown in Figure 7. Need to connect a low pass filter to HDP/HDN output respectively to filter out switch modulation frequency, then measure the differential output of filter to obtain analog output signal.

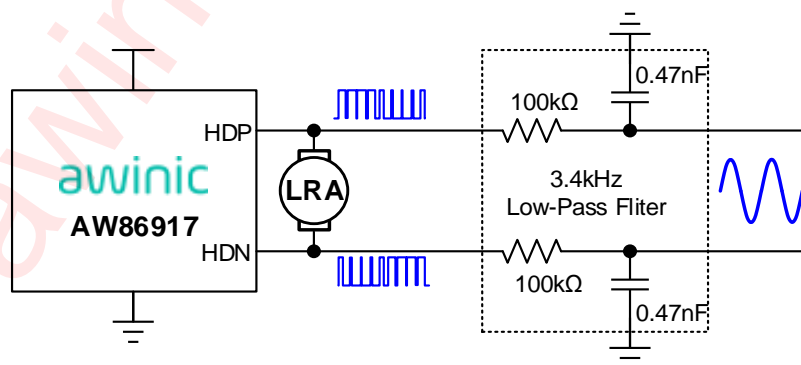

Figure 7 AW86917 test setup

Typical Characteristics

IQ(Quiescent current) test condition: PVDD=9V, Temp=30°C

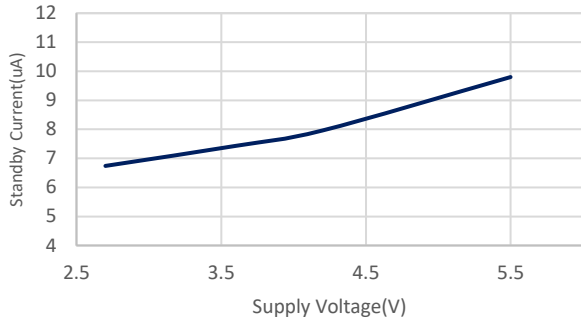

Figure 8 Standby Current Vs Supply Voltage

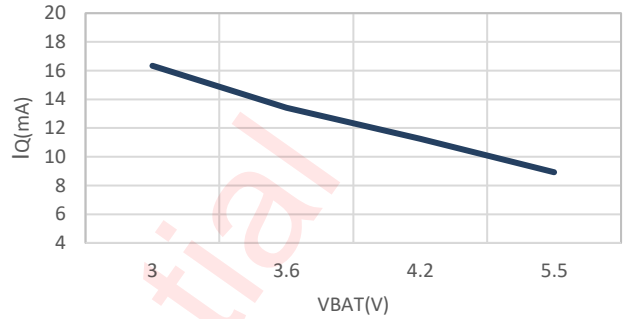

Figure 11 IQ (PVDD=9V) Vs VBAT

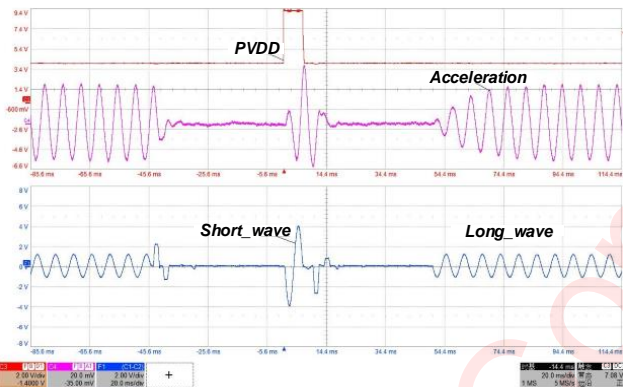

Figure 9 Long Vibration with Short Vibration inside



Figure 12 LRA with Automatic Braking

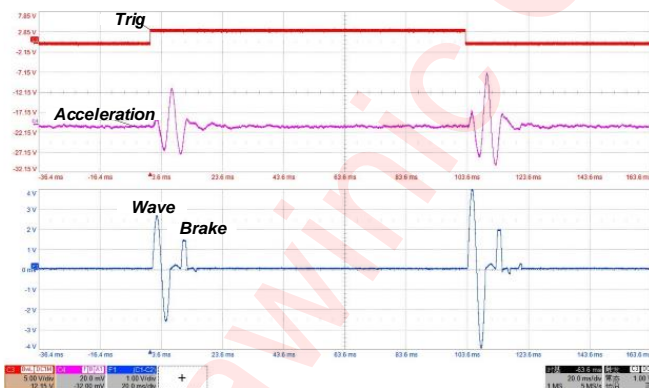

Figure 10 Trig Application

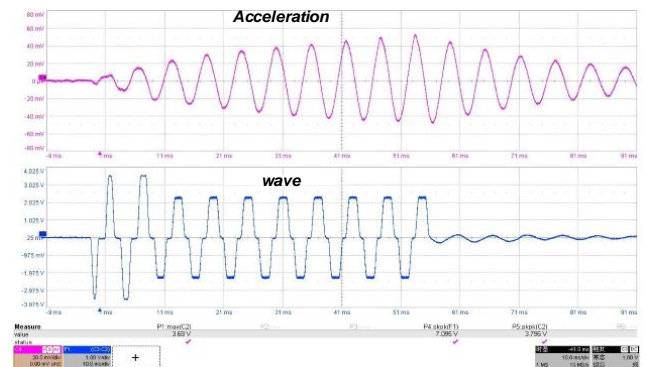

Figure 13 Automatic Resonance Tracking

Detailed Functional Description

Power On Reset

The device provides a power-on reset feature that is controlled by VREG OK. The reset signal will be generated to perform a power-on reset operation, which will reset all circuits and configuration registers. When the VBAT power on, the VREG voltage raises and produce the OK indication, the reset is over.

Operation Mode

The device supports 3 operation modes.

Table 1 Operating Mode

Mode	Condition	Description
Power-Down	VBAT = 0V or RSTN = 0V	Power supply is not ready or RSTN is tie to low. Whole chip shutdown including I2C interface.
Standby	VBAT > 2.7V and RSTN = HIGH and no wave is going	Power supply is ready and RSTN is tie to high. Most parts of the device are power down for low power consumption except I2C interface and LDO.
Active	Playing a waveform	Most parts of the device are working

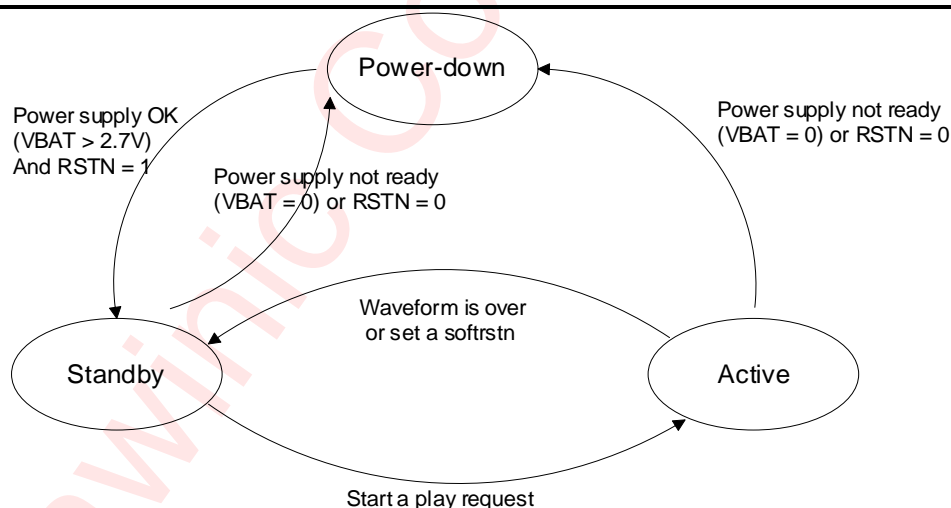

Figure 14 Device operating modes transition

POWER-DOWN MODE

The device switches to power-down mode when the supply voltage is not ready or RSTN pin is set to low. In this mode, all circuits inside this device will be shut down. I2C interface isn't accessible in this mode, and all of the internal configurable registers are cleared.

The device will jump out of the power-down mode automatically when the supply voltages are OK and RSTN pin is set to high.

Standby Mode

The device switches standby mode when the power supply voltages are OK and RSTN pin set to high. In this mode I2C interface is accessible, other modules except LDO module are still powered down. Also in this mode, customer can initialize waveform library in SRAM. Device will be switched to this mode after haptic waveform playback finished.

Active Mode

The device is fully operational in this mode. Boost and H-bridge driver circuits will start to work. Users can send a playback request to make device in this mode.

Power On And Power Down Sequence

This device power on and power down sequence is illustrated in the following figure:

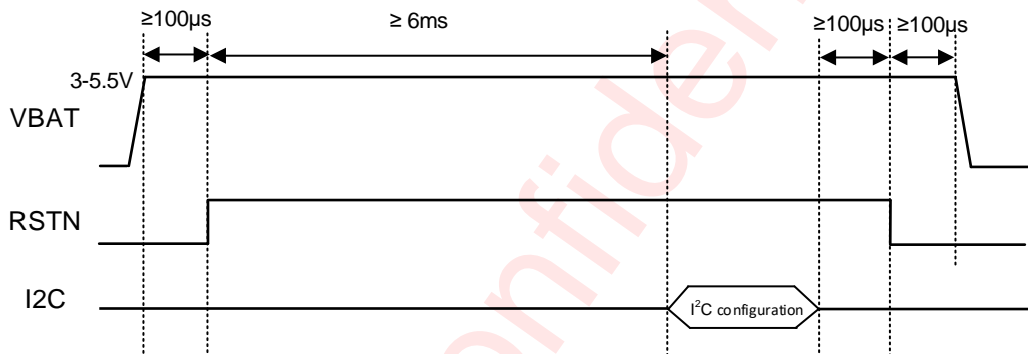

Figure 15 Power On and Power Down Sequence

Playback Sequence

Make sure the device is not in POWER-DOWN MODE before sending a playback request, then the playback sequence is illustrated in the following figure:

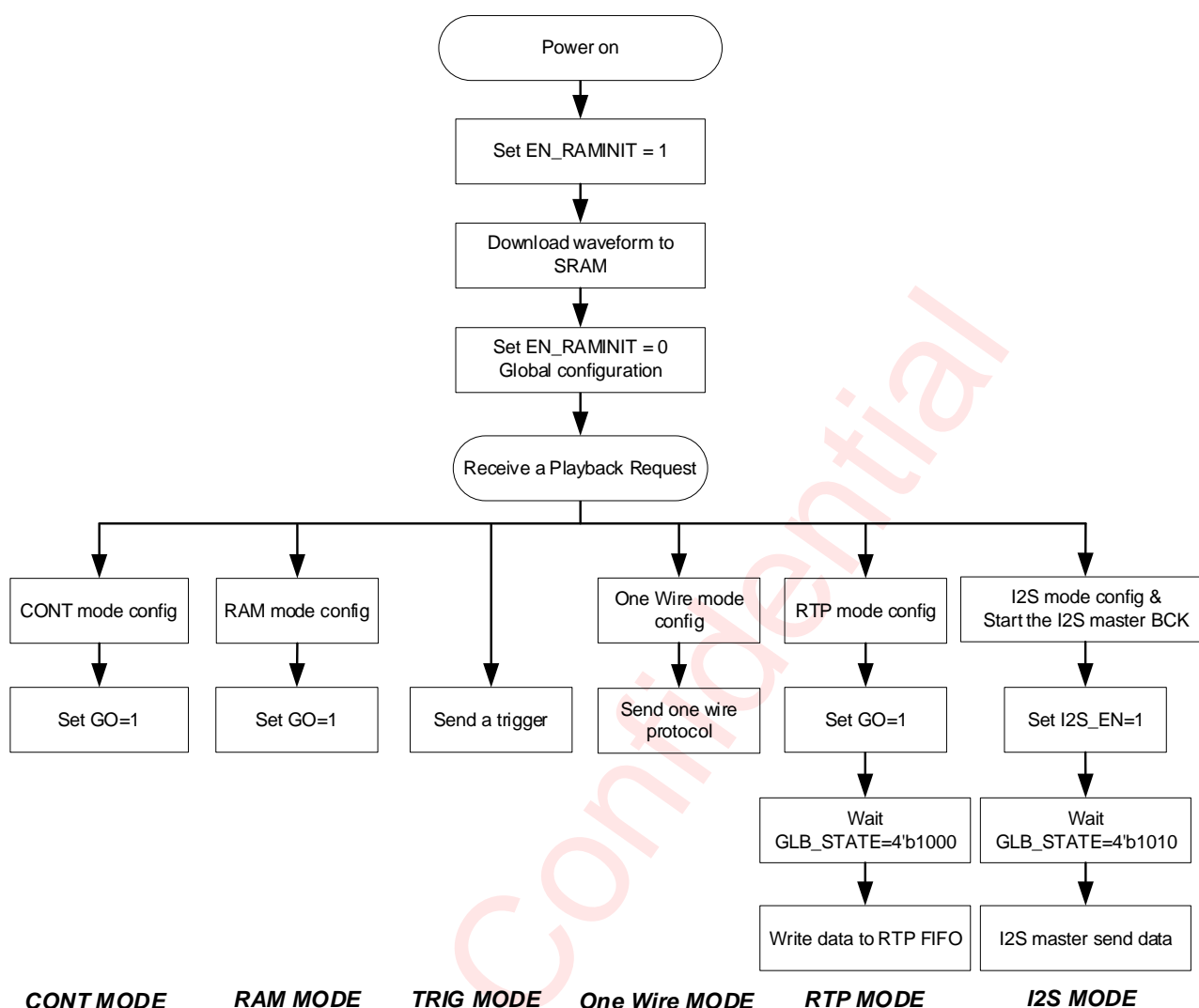

Figure 16 Power up and playback sequence

Software Reset

Writing 0xAA to register CHIPID(0x00) via I2C interface will reset the device internal circuits and all configuration registers.

Battery Voltage Detect

Software can send command to detect the battery voltage.

Detect steps:

- Set EN_RAMINIT to 1 in register 0x43;
- Set VBAT_GO to 1 in register 0x52;
- Delay 3ms;
- Set EN_RAMINIT to 0 in register 0x43;
- Read VBAT_LO in register 0x57 and VBAT in register 0x55. Code= {VBAT, VBAT_LO}.

The code is a 10bit unsigned number.

$$VBAT = \frac{6.1 \times code}{1024} (V)$$

Constant Vibration Strength

The device features power-supply feedback. If the supply voltage discharge over time, the vibration strength remains the same as long as enough supply voltage is available to sustain the required output voltage. It is especially useful for ring application.

LRA Consistency Calibration

Different motor batches, assembly conditions and other factors can result in f0 deviation of LRA. When the drive waveform does not match the LRA monomer, the vibration may be inconsistent and the braking effect becomes worse, especially for short vibration waveforms. So it's necessary to perform consistency calibration of LRA. Firstly the power-on f0 detection can be launched to get the f0 of LRA. Secondly the waveform frequency stored in SRAM and the f0 of LRA are used to calculate the code for calibration. The f0 accuracy after LRA consistency calibration is $\pm 2\text{Hz}$.

LRA Resistance Detect

Software can send command to detect the LRA's resistance. Based on this information host can diagnosis used LRA's status.

Detect steps:

- Set EN_RAMINIT to 1 in register 0x42;
- Set RL_OS to 1 in register 0x51;
- Set DIAG_GO to 1 in register 0x52;
- Delay 3ms;
- Set EN_RAMINIT to 0 in register 0x43;
- Read RL in register 0x53 and RL_LO in register 0x57. Code= {RL, RL_LO}.

The code is a 10bit unsigned number.

$$RL = \frac{678 \times code}{1024 \times d2s_gain} (\Omega)$$

Flexible Haptic Data Playback

The device offers multiple ways to playback haptic effects data. The PLAY_MODE bits select RAM mode, RTP mode, CONT mode. Additional flexibility is provided by the three hardware TRIG pins, which can override PLAY_MODE bit to playback haptic effects data as configuration.

The device contains 12 kB of integrated SRAM to store customer haptic waveforms' data. The whole SRAM is separated to RAM waveform library and RTP FIFO region by base address. And RAM waveform library is including waveform library version, waveform header and waveform data.

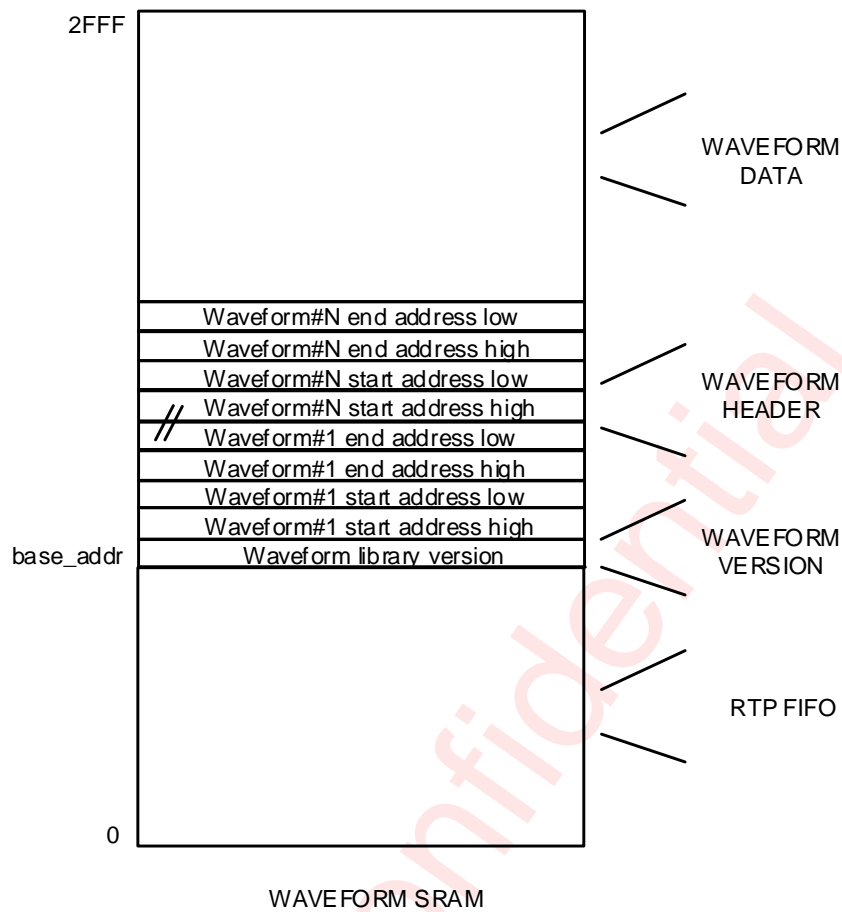

Figure 17 Data structure in SRAM

SRAM mode and TRIG mode playback the waveforms in RAM waveform library and RTP mode playback the waveform data written in RTP FIFO, CONT mode playback non-filtered or filtered square wave with rated drive voltage.

Sram Structure

A RAM waveform library consists of a waveform version byte, a waveform header section, and the waveform data content. The waveform header defines the data boundaries for each waveform ID in the data field, and the waveform data contains a signed data format (2's complement) to specify the magnitude of the drive.

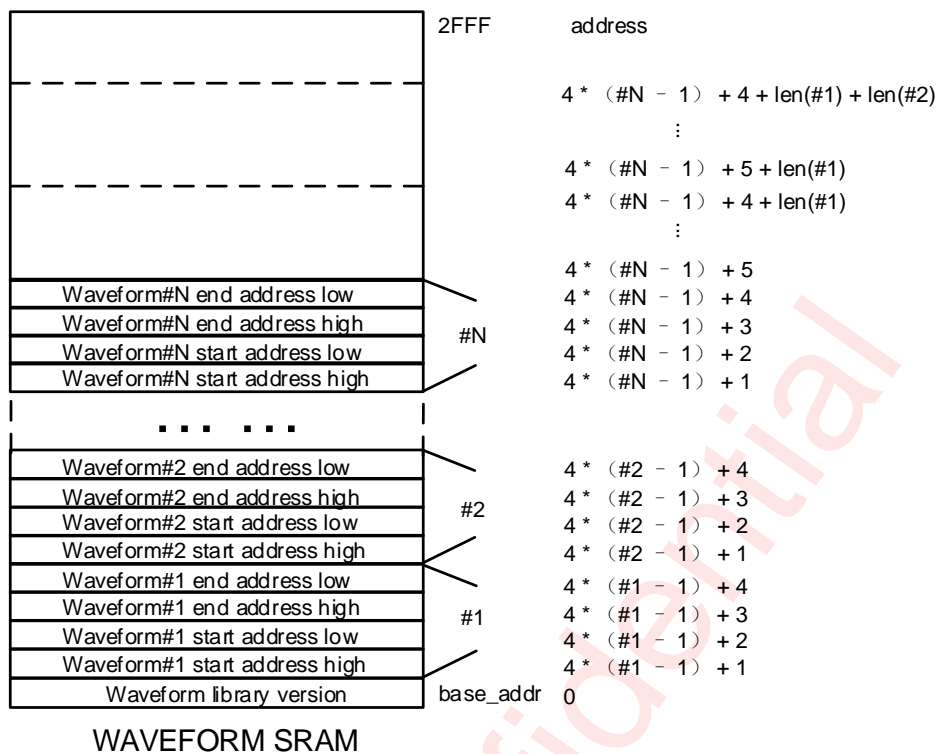

Figure 18 Waveform library data structure

Waveform version:

One byte located on SRAM base address, setting to different value to identify different version of RAM waveform library.

Waveform header:

The waveform header block consist of N-boundary definition blocks of 4 bytes each. N is the number of waveforms stored in the SRAM (N cannot exceed 127). Each of the boundary definition blocks contain the start address (2 bytes) and end address (2 bytes). So the total length of waveform header block are $N*4$ bytes.

The start address contains the location in the memory where the waveform data associated with this waveform begins.

The end address contains the location in the memory where the waveform data associated with this waveform ends.

The waveform ID is determined after base address is defined. Four bytes begins with the address next to base address are the first waveform ID's header, and next four bytes are the second waveform ID's header, and so on.

Waveform data:

The waveform data contains a signed data format (2's complement) to specify the magnitude of the drive. The begin address and end address is specified in waveform ID's header.

Waveform library initialization steps:

- Prepare waveform library data including: waveform library version, waveform header fields for waveform in library and waveform data of each waveform;
- Set register EN_RAMINIT=1 in register 0x43, to enable SRAM initial;
- Delay 1ms;

- Set base address (register 0x2D, 0x2E);
- Set ram address (register 0x40, 0x41);
- Write waveform library data into register 0x42 continually until all the waveform library data written;
- Set register EN_RAMINIT=0, to disable SRAM initial.

Ram Mode

To playback haptic data with RAM mode, the waveform ID must first be configured into the waveform playback queue and then the waveform can be played by writing GO bit register.

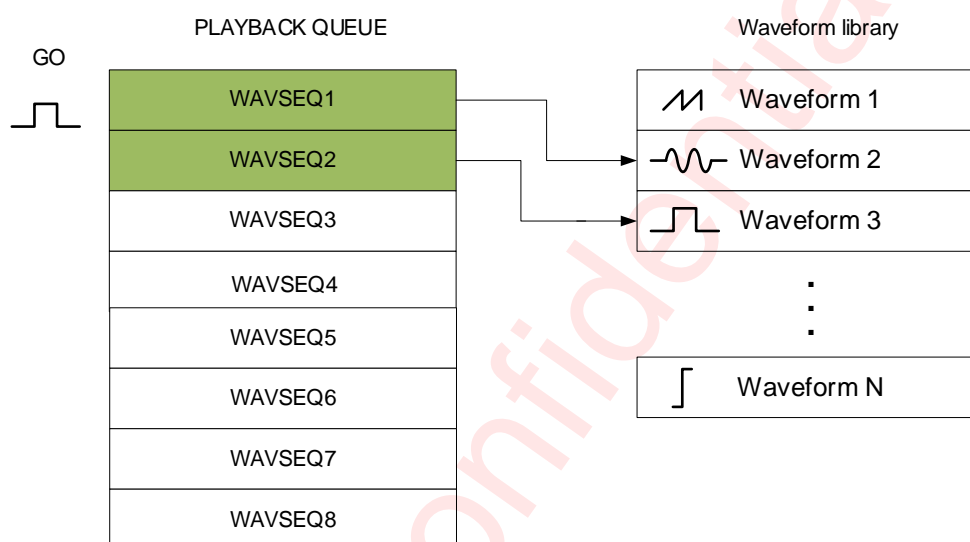

Figure 19 RAM mode playback

The waveform playback queue defines waveform IDs in waveform library for playback. Eight WAVSEQx registers queue up to eight library waveforms for sequential playback. A waveform ID is an integer value referring to the index of a waveform in the waveform library. Playback begins at WAVSEQ1 when the user triggers the waveform playback queue. When playback of that waveform ends, the waveform queue plays the next waveform ID held in WAVSEQ2 (if non-zero). The waveform queue continues in this way until the queue reaches an ID value of zero or until all eight IDs are played whichever comes first.

The waveform ID is a 7-bit number. The MSB of each ID register can be used to implement a delay between queue waveforms. When the SEQxWAIT is high, bits 6-0 indicate the length of the wait time. The wait time for that step then becomes $\text{WAVSEQ}[6:0] \times \text{wait_time unit}$. Wait_time unit can be configuration of WAIT SLOT register (in 0x16 register).

The device allows for looping of individual waveforms by using the SEQxLOOP registers. When used, the state machine will loop the particular waveform the number of times specified in the associated SEQxLOOP register before moving to the next waveform. The device allows for looping of the entire playback sequence by using the MAIN_LOOP register. The waveform-looping feature is useful for long, custom haptic playbacks, such as a haptic ringtone.

Playback steps:

- Waveform library must be initialized before playback;
- Set PLAY_MODE bit to 0 in register 0x08;
- Set playback queue registers (0x0A ~ 0x11) as desired;

- Set playback loop registers (0x12~ 0x16) as desired;
- Set GO bit to 1 in register 0x09 to trigger waveform playback;
- Device will be switched to STANDBY mode after haptic waveform playback finished.

Rtp Mode

The real-time playback mode is a simple, single 8-bit register interface that holds an amplitude value. When real-time playback is enabled, begin to enters a register value to RTP_DATA over the I2C will trigger the playback, the value is played until the data sending finished or removes the device from RTP mode. The maximum FIFO space is 4Kbyte. During writing data to the RTP_DATA register, the I2C speed cannot be too low, see the table below for details.

Table 2 Minimum I2C speed

WAVDAT_MODE	Sample rate of waveform	I2C speed
2'b10/2'b11	12K	$\geq 250\text{kHz}$
2'b00	24K	$\geq 400\text{kHz}$
2'b01	48K	1MHz

After FF_AEM or FF_AFM register is set to 0, HOST can obtain the RTP FIFO almost empty or almost full status through interrupt signal(pin INTN) or read FF_AES or FF_AFS register. RTP FIFO almost empty and almost full threshold can be configured through FIFO_AE and FIFO_AF registers.

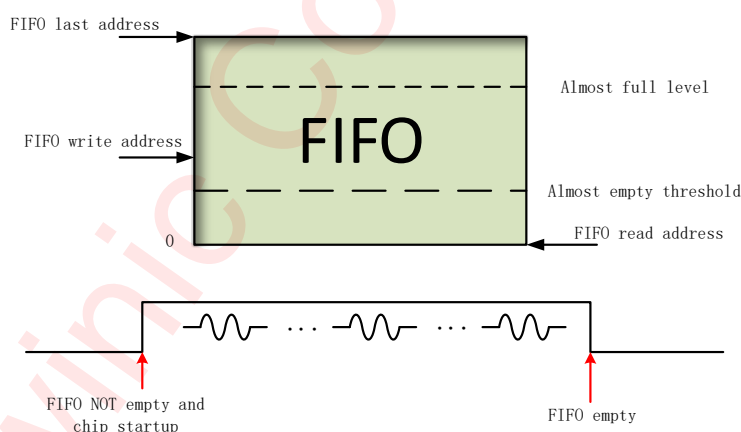

Figure 20 RTP mode playback

Playback steps:

- Prepare RTP data before playback;
- Set PLAY_MODE bit to 1 in register 0x08;
- Set GO bit to 1 in register 0x09 to trigger waveform playback;
- Delay 1ms.
- Check GLB_STATE=4'b1000, if HOST don't send data to FIFO, chip will wait for RTP data coming in this state forever;
- Write RTP data continually to register 0x32 to playback RTP waveform;

- HOST need monitor the full and empty status for RTP FIFO;
- Device will be switched to STANDBY mode after wave data in RTP FIFO is played empty.

Trig Mode

The device have three dedicated hardware pins for quickly trigger haptic data playback. Each pin can be configured posedge/negedge/both-edge/level trigger.

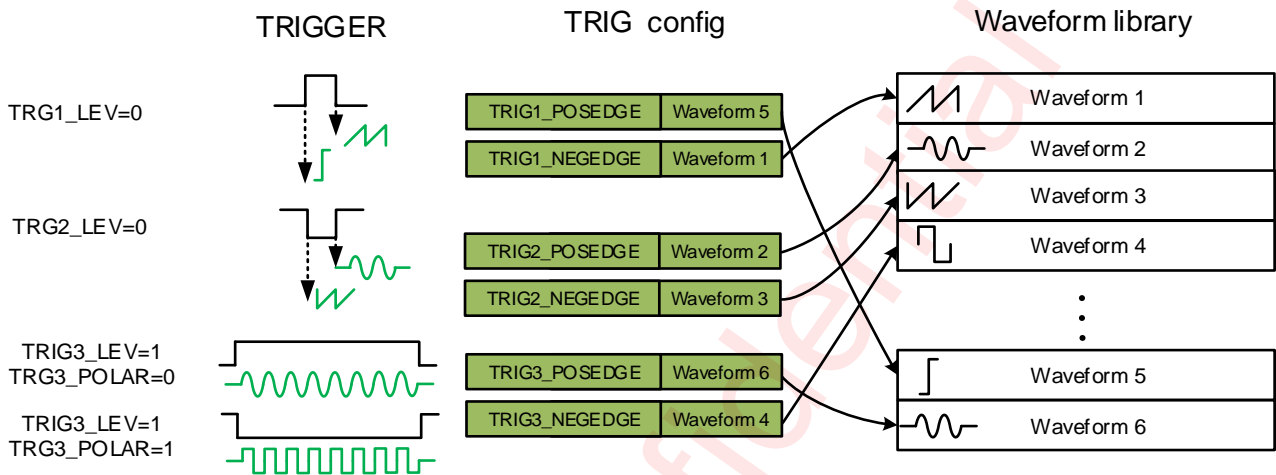

Figure 21 TRIG mode playback

Edge mode or level mode is accessible by configuring register TRGx_LEV. When a edge mode is needed, user should set TRGx_LEV =0. In edge mode, register TRGxSEQ_P and TRGx_POS respectively represent the waveform and enable signal of positive edge, where register TRGxSEQ_N and TRGx_NEG respectively represent the waveform and enable signal of negative edge.

When a level mode is needed, user should set TRGx_LEV =1, and positive level and negative level can be supported by setting register TRGX_POLAR=0 and setting TRGX_POLAR=1.

Table 3 TRIG MODE CONFIG

I2C reg				Trigger	Waveform
TRGx_LVL	TRGx_POLAR	TRGx_POS	TRGx_NEG		
0	X	0	0	-	none
	X	1	0	↑	TRGxSEQ_P
	X	0	1	↓	TRGxSEQ_N
	X	1	1	↑ / ↓	TRGxSEQ_P / TRGxSEQ_N
1	0	X	X	High level	TRGxSEQ_P
	1	X	X	Low level	TRGxSEQ_N

Playback steps:

- Waveform library must be initialized before playback;
- Set trigger playback registers (0x33 ~ 0x3A) as desired;
- Send trigger pulse (≥1μs) or trigger level (≥1ms) on TRIG pins to playback waveform;
- Device will be switched to STANDBY mode after haptic waveform playback finished.

One wire Mode

The function of one wire mode mainly transfer two information : sequence number and gain of waveform, TRIG1 is the interface pin.

Playback steps:

- Waveform library must be initialized before playback;
- Set TRG_ONEWIRE to 1 in register 0x3A to enable one wire mode;
- Set 0x3E = 0x58 to enable one wire the lowest priority of playback;
- Set 0x3C = 0x75, configure this register above this value in order to receive one wire protocol (about 2.5ms which is the minimum waiting time after chip wakeup, default value is 20 μ s)
- Determine sequence number and gain of waveform which you want to playback;
- Combine sequence number and gain data into a 15 bit transformation data (low 8 bit is gain, high 7 bit is sequence number), the data is sent from the lowest bit;
- Chip will automatically enter standby mode after playing. The interval time between two sending protocol data should be greater than "3ms+time length of waveform".



Figure 22 One wire mode playback

Cont Mode

The CONT mode mainly performs two functions: F0 detection and real-time resonance-frequency tracking. F0 detection can be launched by setting EN_F0_DET=1 and BRK_EN =1. When set TRACK_EN=1, real-time resonance-frequency tracking will be launched by tracking the BEMF of actuator constantly. It provides stronger and more consistent vibrations and lower power consumption. If the resonant frequency shifts for any reason, the function tracks the frequency from cycle to cycle. When TRACK_EN is set to 0, the width of waveform of cont mode is determined by DRV_WIDTH in register 0x1A.

When the EDGE_FRE register is set to 4'b1xxx, the CONT mode outputs a filtered square wave. The edge of filtered square wave is composed of SIN or COS wave whose frequency can be configured by EDGE_FRE register. When SIN_MODE register is set to 1, filtered square wave is composed of COS wave.

Playback steps:

- Set PLAY_MODE = 2 in register 0x08 to enable CONT mode ;
- (optional)Set EN_F0_DET = 1 and BRK_EN =1 to enable F0 detection;
- Set cont mode by configuring registers(0x18~0x20 and 0x22);
- Set GO bit to 1 in register 0x09 to trigger waveform playback;
- Delay 1ms;
- If enable F0 detection, read until GLB_STATE=0. then get F0 information from registers(0x25~0x28).
- Device will be switched to STANDBY mode after haptic waveform playback finished;

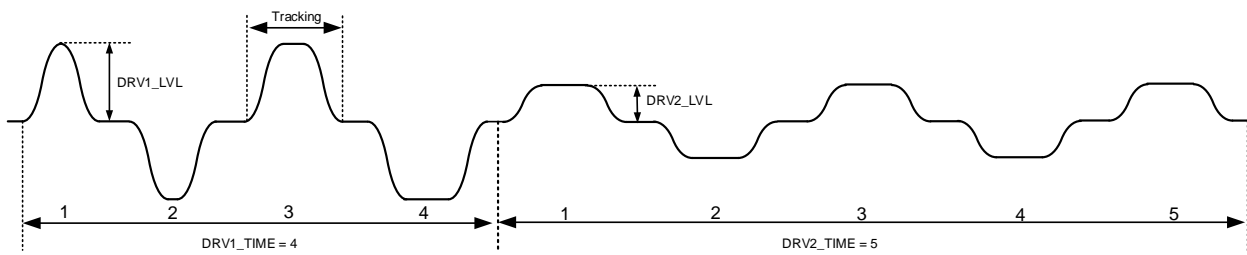

Figure 23 Cont mode playback

I2S Mode

Device support I2S interface to playback wave data from I2S master. I2S mode can be used to playback waveform following the music which is playing.

Playback steps:

- Set I2S_PIN =1;
- Set 0x6B = 0x28, to enable fast input IO
- Start BCK from I2S master;
- Set I2S playback registers (0x4A ~ 0x4B) as desired;
- Set I2S_EN =1;
- Wait GLB_STATE=4'b1010;
- Send I2S data to device.

Auto Brake Engine

An auto-brake engine is integrated into this device. Users can adjust the brake strength by setting D2S_GAIN in register 0x49. The greater D2S_GAIN, the greater brake strength and the worse loop stability. Auto-brake engine is disabled when setting BRK_EN=0 or BRK_TIME=0.

To enable Auto-brake engine, there are some points to note:

- TRGx_BRK in register 0x39,0x3A should be set to 1 when in TRIG mode;
- Auto-brake engine will not work when BRK_EN=0 in register 0x08;
- Auto-brake engine will not work when EN_F0_DET in register 0x18 is set to 1;
- Auto-brake engine will not work when BRK_TIME in register 0x21 is set to 0;
- Device will be switched to STANDBY mode after haptic waveform playback finished.

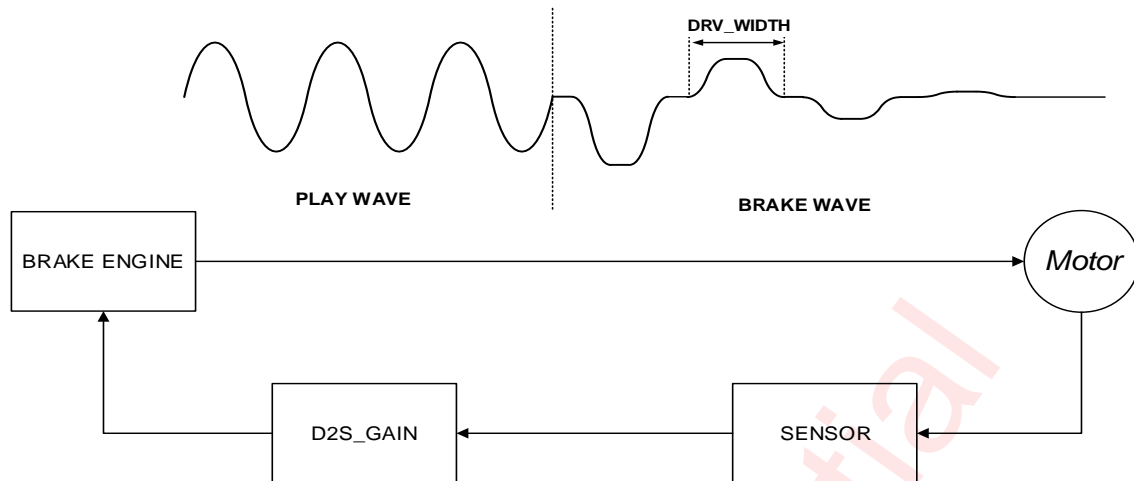

Figure 24 Brake loop

DC-DC Converter

The device integrated peak current mode synchronous PWM Boost as H-bridge power stage supply, significantly increase the output voltage dynamic range. Reduces the size of external components and saves PCB space by using about 1.6 MHz switching frequency. Boost output voltage can be set through the I2C register 0x06;

The device synchronous Boost with soft-start function to prevent overshoot current at powering-on; integrated the output protection circuit and self-recovery function; integrated Anti-Ring circuit to reduce EMI in DCM mode; built-in substrate switching shutdown circuit, effectively preventing the input and output leakage current anti-irrigation.

Protection Mechanisms

Over Voltage Protection (OVP)

The boost circuit has integrated the over voltage protection control loop. When the output voltage PVDD is above the threshold, the boost circuits will stop working, until the voltage of PVDD going down and under the normal fixed working voltage.

Over Temperature Protection (OTP)

The device has automatic temperature protection mechanism which prevents heat damage to the chip. It is triggered when the junction temperature is larger than the preset temperature high threshold (default = 160°C). When it happens, the output stages will be disabled. When the junction temperature drops below the preset temperature low threshold (less than 130°C), the output stages will start to operate normally again

Over Current (Short) Protection (OCP)

The short circuit protection function is triggered when HDP/HDN is short too PVDD/GND or HDP is short to HDN, the output stages will be shut down to prevent damage to itself. When the fault condition is disappeared, the output stages of device will restart.

Vbat Under Voltage Lock Out Protection (UVLO)

The device has a battery monitor that monitors the VBAT level to ensure that is above threshold 2.7V, In the event of a VBAT drop, the device immediately power down the Boost and H-bridge driver and latches the UVLO flag.

Drive Data Error Protection (DDEP)

When haptic data sent to drive LRA is error such as: a DC data or almost DC data, it will cause the LRA heat to brake. The device configurable immediately power down the Boost and H-bridge driver and latched the DDEP flag.

Digital Audio Interface

Wave data is transferred between the host processor and the device via the Digital Audio Interface. The digital audio interface via 3 dedicated pins:

- BCK
- WCK(only 48K/44.1K is supported)
- DATAI

Two-slot I²S are supported in this device. The digital audio Interface on this device is slave only and flexible with data width options, including 16, 20, 24, or 32 bits by configurable registers.

Three modes of I²S are supported, including standard I²S mode, left-justified mode and right-justified data mode, which can be configured via I2SCFG1.I2SMD.These modes are all MSB-first, with data width programmable via I2SCFG1.I2SFS.

The bit clock BCK is used to sample the data across the digital audio interface. The number of bit-clock pulses in a frame is defined as slot length. Three kind of slot length are supported (16/24/32) via configurable register I2SCFG1.I2SBCK. The frequency of BCK can be calculated according to the following equation:

$$BCK\ frequency = SampleRate * SlotLength * SlotNumber$$

SampleRate: Sample rate for this digital audio interface;

SlotLength: The length of one audio slot in unit of BCK clock;

The word select and bit clock signals of the I²S input are the reference signals for the digital audio interface and Phased Locked Loop (PLL).

The audio source can be from left channel, right channel or the average of the left and right channel, which is controlled by I2SCFG2.CHSEL.

Table 4 Supported I2S interface parameters

Interface format(MSB first)	Data width	BCK frequency
Standard I ² S	16b 20b/24b/32b	32fs/48fs /64fs 48fs /64fs
left-justified	16b 20b/24b/32b	32fs/48fs /64fs 48fs /64fs
right-justified	16b 20b/24b/32b	32fs /48fs /64fs 48fs /64fs

Standard PS Mode

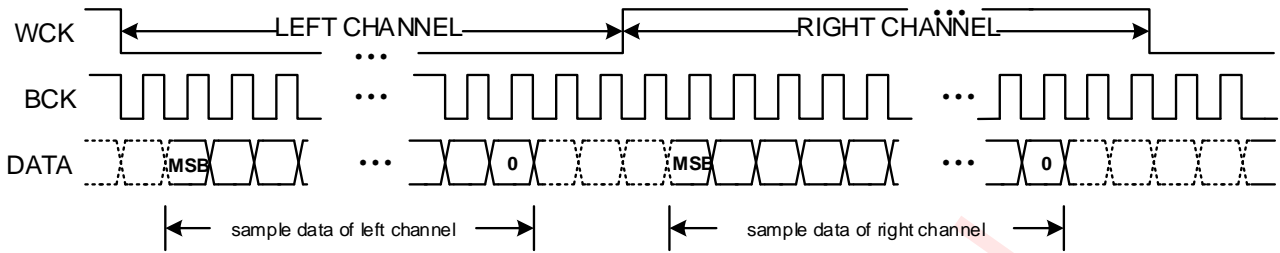

Figure 25 I²S Timing for Standard I²S Mode

- When WCK=0 indicating the left channel data, and WCK=1 indicating the right channel data.
- The MSB of the left channel is valid on the second rising edge of the bit clock after the falling edge of the word clock. Similarly the MSB of the right channel is valid on the second rising edge of the bit clock after the rising edge of the word clock.

Left-Justified Mode

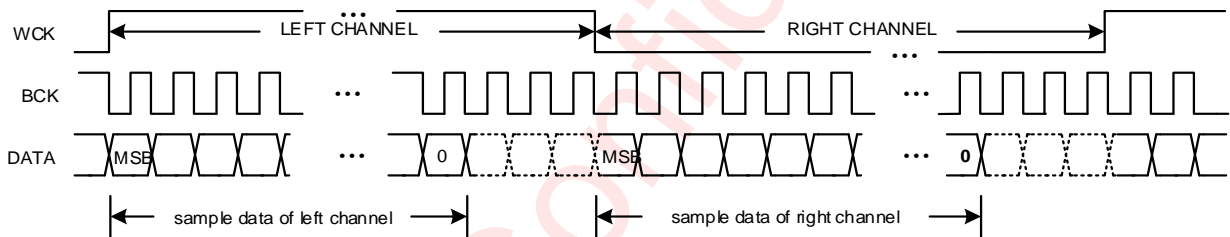

Figure 26 I²S Timing for Left-Justified Mode

- When WCK=1 indicating the left channel data, and WCK=0 indicating the right channel data.
- The MSB of the left channel is valid on the first rising edge of the bit clock after the rising edge of the word clock. Similarly the MSB of the right channel is valid on the first rising edge of the bit clock after the falling edge of the word clock.

Right-Justified Mode

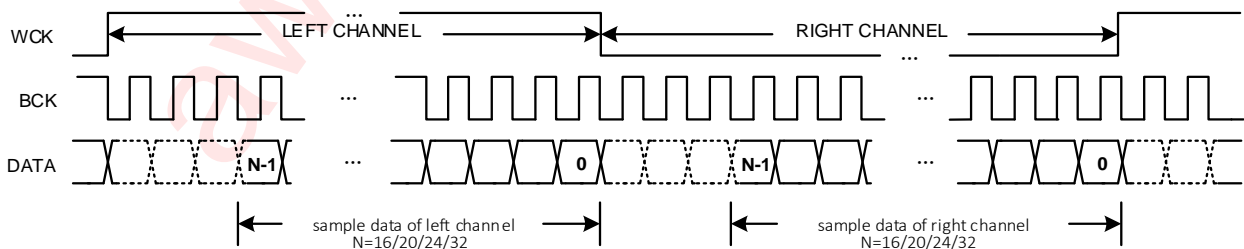

Figure 27 I²S Timing for Right-Justified Mode

- When WCK is high indicating the left channel data, and WCK=0 indicating the right channel data.
- The LSB (bit 0) of the left channel is valid on the rising edge of the bit clock preceding the falling edge of the word clock. Similarly, the LSB (bit 0) of the right channel is valid on the rising edge of the bit clock preceding the rising edge of the word clock.

I2C Interface

This device supports the I²C serial bus and data transmission protocol in fast mode at 400kHz and fast mode plus at 1000kHz. This device operates as a slave on the I²C bus. Connections to the bus are made via the open-drain I/O pins SCL and I pin SDA. The pull-up resistor can be selected in the range of 1k~10kΩ and the typical value is 4.7kΩ. This device can support different high level (1.8V~3.3V) of this I2C interface.

Device Address

The I2C device address (7-bit) can be set using the AD pin according to the following table:

Table 5 Address Selection

AD	I2C address (7-bit)
0	0x5A
1	0x5B

Data Validation

When SCL is high level, SDA level must be constant. SDA can be changed only when SCL is low level.

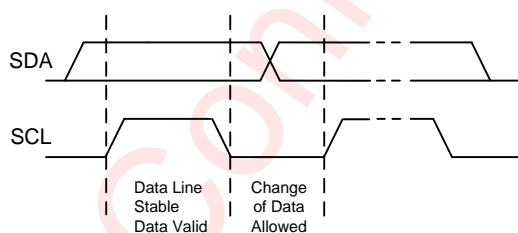

Figure 28 Data Validation Diagram

General I2C Operation

The I2C bus employs two signals, SDA (data) and SCL (clock), to communicate between integrated circuits in a system. The device is addressed by a unique 7-bit address; the same device can send and receive data. In addition, Communications equipment has distinguish master from slave device: In the communication process, only the master device can initiate a transfer and terminate data and generate a corresponding clock signal. The devices using the address access during transmission can be seen as a slave device.

SDA and SCL connect to the power supply through the current source or pull-up resistor. SDA and SCL default is a high level. There is no limit on the number of bytes that can be transmitted between start and stop conditions. When the last word transfers, the master generates a stop condition to release the bus.

START state: The SCL maintain a high level, SDA from high to low level

STOP state: The SCL maintain a high level, SDA pulled low to high level

Start and Stop states can be only generated by the master device. In addition, if the device does not produce STOP state after the data transmission is completed, instead re-generate a START state (Repeated START, Sr), and it is believed that this bus is still in the process of data transmission. Functionally, Sr state and START state is the same. As shown in Figure 29.

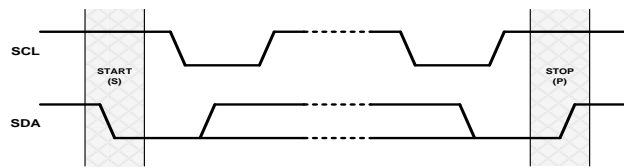

Figure 29 START and STOP state generation process

In the data transmission process, when the clock line SCL maintains a high level, the data line SDA must remain the same. Only when the SCL maintain a low level, the data line SDA can be changed, as shown in Figure 30. Each transmission of information on the SDA is 9 bits as a unit. The first eight bits are the data to be transmitted, and the first one is the most significant bit (Most Significant Bit, MSB), the ninth bit is an acknowledgment bit (Acknowledge, ACK or A), as shown in Figure 31. When the SDA transmits a low level in ninth clock pulse, it means the acknowledgment bit is 1, namely the current transmission of 8 bits data are confirmed, otherwise it means that the data transmission has not been confirmed. Any amount of data can be transferred between START and STOP state.

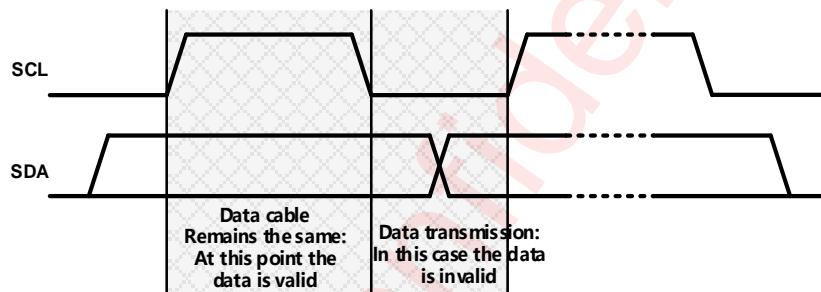

Figure 30 The data transfer rules on the I2C bus

The whole process of actual data transmission is shown in Figure 31. When generating a START condition, the master device sends an 8-bit data, including a 7-bit slave addresses (Slave Address), and followed by a "read / write" flag ($\overline{R/W}$). The flag is used to specify the direction of transmission of subsequent data. The master device will produce the STOP state to end the process after the data transmission is completed. However, if the master device intends to continue data transmission, you can directly send a Repeated START state, without the need to use the STOP state to end transmission.

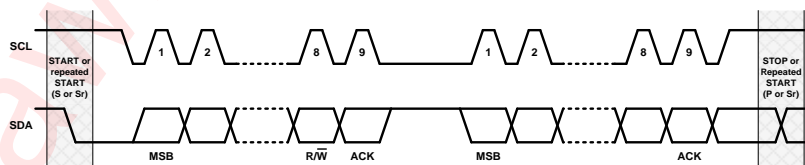

Figure 31 Data transmission on the I2C bus

Write Process

Writing process refers to the master device write data into the slave device. In this process, the transfer direction of the data is always unchanged from the master device to the slave device. All acknowledge bits are transferred by the slave device, in particular, the device as the slave device, the transmission process in accordance with the following steps, as shown in Figure 32:

Master device generates START state. The START state is produced by pulling the data line SDA to a low level when the clock SCL signal is a high level.

Master device transmits the 7-bits device address of the slave device, followed by the "read / write" flag (flag $\overline{R/\overline{W}} = 0$);

The slave device asserts an acknowledgment bit (ACK) to confirm whether the device address is correct;

The master device transmits the 8-bit register address to which the first data byte will written;

The slave device asserts an acknowledgment (ACK) bit to confirm the register address is correct;

Master sends 8 bits of data to register which needs to be written;

The slave device asserts an acknowledgment bit (ACK) to confirm whether the data is sent successfully;

If the master device needs to continue transmitting data by sending another pair of data bytes, just need to repeat the sequence from step 6. In the latter case, the targeted register address will have been auto-incremented by the device.

The master device generates the STOP state to end the data transmission.

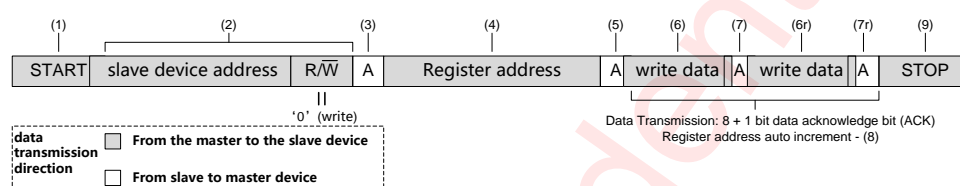

Figure 32 Writing process (data transmission direction remains the same)

Read Process

Reading process refers to the slave device reading data back to the master device. In this process, the direction of data transmission will change. Before and after the change, the master device sends START state and slave address twice, and sends the opposite "read/write" flag. In particular, AW86917 as the slave device, the transmission process carried out by following steps listed in Figure 33:

Master device asserts a start condition;

Master device transmits the 7 bits address of the device, and followed by a "read / write" flag ($\overline{R/\overline{W}} = 0$);

The slave device asserts an acknowledgment bit (ACK) to confirm whether the device address is correct;

The master device transmits the register address to make sure where the first data byte will read;

The slave device asserts an acknowledgment (ACK) bit to confirm whether the register address is correct or not;

The master device restarts the data transfer process by continuously generating STOP state and START state or a separate Repeated START;

Master sends 7-bits address of the slave device and followed by a read / write flag (flag $\overline{R/\overline{W}} = 1$) again;

The slave device asserts an acknowledgment (ACK) bit to confirm whether the register address is correct or not;

Master transmits 8 bits of data to register which needs to be read;

The slave device sends an acknowledgment bit (ACK) to confirm whether the data is sent successfully;

The device automatically increment register address once after sent each acknowledge bit (ACK),

The master device generates the STOP state to end the data transmission.

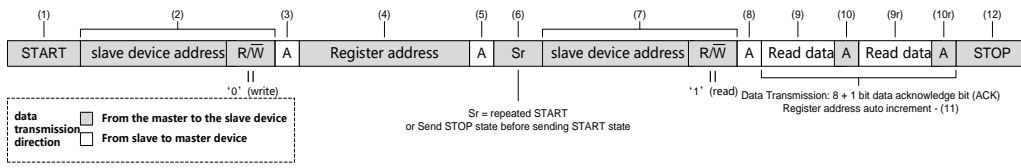

Figure 33 Reading process (data transmission direction remains the same)

awinic Confidential

Register Configuration

Register List

ADDR	NAME	R/W	Bit7	Bit6	Bit5	Bit4	Bit3	Bit2	Bit1	Bit0	Default	
0x00	SRST	RO	CHIP_ID									0x06
0x01	SYSST	RO			UVLS	FF_AES	FF_AFS	OCD5	OTS	DONES	0x10	
0x02	SYSINT	RC			UVLI	FF_AEI	FF_AFI	OCDI	OTI	DONEI	0x10	
0x03	SYSINTM	RW			UVLM	FF_AEM	FF_AFM	OCDM	OTM	DONEM	0xFF	
0x06	PLAYCFG1	RW		BST_MODE	BST_VOUT_RDA						0x20	
0x07	PLAYCFG2	RW	GAIN									0x80
0x08	PLAYCFG3	RW		AUTO_BST	STOP_MODE				BRK_EN	PLAY_MODE	0x44	
0x09	PLAYCFG4	RW							STOP	GO	0x00	
0x0A	WAVCFG1	RW	SEQ1WAIT	WAVSEQ1							0x01	
0x0B	WAVCFG2	RW	SEQ2WAIT	WAVSEQ2							0x00	
0x0C	WAVCFG3	RW	SEQ3WAIT	WAVSEQ3							0x00	
0x0D	WAVCFG4	RW	SEQ4WAIT	WAVSEQ4							0x00	
0x0E	WAVCFG5	RW	SEQ5WAIT	WAVSEQ5							0x00	
0x0F	WAVCFG6	RW	SEQ6WAIT	WAVSEQ6							0x00	
0x10	WAVCFG7	RW	SEQ7WAIT	WAVSEQ7							0x00	
0x11	WAVCFG8	RW	SEQ8WAIT	WAVSEQ8							0x00	
0x12	WAVCFG9	RW	SEQ1LOOP				SEQ2LOOP				0x00	
0x13	WAVCFG10	RW	SEQ3LOOP				SEQ4LOOP				0x00	
0x14	WAVCFG11	RW	SEQ5LOOP				SEQ6LOOP				0x00	
0x15	WAVCFG12	RW	SEQ7LOOP				SEQ8LOOP				0x00	
0x16	WAVCFG13	RW		WAITSLLOT			MAINLOOP				0x00	
0x18	CONTCFG1	RW	EDGE_FRE				EN_F0_DET		BRK_BST_MD	SIN_MODE	0xD1	
0x19	CONTCFG2	RW	F_PRE									0x8D
0x1A	CONTCFG3	RW	DRV_WIDTH									0x6A
0x1C	CONTCFG5	RW	BST_BRK_GAIN				BRK_GAIN				0x58	
0x1D	CONTCFG6	RW	TRACK_EN	DRV1_LVL							0xFF	
0x1E	CONTCFG7	RW		DRV2_LVL							0x50	
0x1F	CONTCFG8	RW	DRV1_TIME									0x04
0x20	CONTCFG9	RW	DRV2_TIME									0x06
0x21	CONTCFG10	RW	BRK_TIME									0x08
0x22	CONTCFG11	RW	TRACK_MARGIN									0x0C
0x25	CONTRD14	RO	F_LRA_F0_H									0x00
0x26	CONTRD15	RO	F_LRA_F0_L									0x00
0x27	CONTRD16	RO	CONT_F0_H									0x00
0x28	CONTRD17	RO	CONT_F0_L									0x00
0x2D	RTPCFG1	RW			BASE_ADDR_H						0x08	
0x2E	RTPCFG2	RW	BASE_ADDR_L									0x00
0x2F	RTPCFG3	RW	FIFO_AEH				FIFO_AFH				0x26	
0x30	RTPCFG4	RW	FIFO_AEL									0x00
0x31	RTPCFG5	RW	FIFO_AFL									0x00
0x32	RTPDATA	RW	RTP_DATA									0x00
0x33	TRGCFG1	RW	TRG1_POS	TRG1SEQ_P							0x01	
0x34	TRGCFG2	RW	TRG2_POS	TRG2SEQ_P							0x01	
0x35	TRGCFG3	RW	TRG3_POS	TRG3SEQ_P							0x01	
0x36	TRGCFG4	RW	TRG1_NEG	TRG1SEQ_N							0x01	
0x37	TRGCFG5	RW	TRG2_NEG	TRG2SEQ_N							0x01	
0x38	TRGCFG6	RW	TRG3_NEG	TRG3SEQ_N							0x01	
0x39	TRGCFG7	RW	TRG1_POLAR	TRG1_LEV	TRG1_BRK	TRG1_BST	TRG2_POLAR	TRG2_LEV	TRG2_BRK	TRG2_BST	0x33	
0x3A	TRGCFG8	RW	TRG3_POLAR	TRG3_LEV	TRG3_BRK	TRG3_BST	TRG_ONEWIRE	TRG1_STOP	TRG2_STOP	TRG3_STOP	0x30	
0x3C	GLBCFG2	RW	START_DLY									0x01
0x3E	GLBCFG4	RW	GO_PRI0			TRG3_PRI0		TRG2_PRI0		TRG1_PRI0		0x1B
0x3F	GLBRD5	RO	GLB_STATE									0x00

0x40	RAMADDRH	RWS	RAMADDRH						0x00		
0x41	RAMADDRL	RWS	RAMADDRL						0x00		
0x42	RAMDATA	RWS	RAMDATA						0x00		
0x43	SYSCTRL1	RW	VBAT_MODE				EN_RAMINIT	EN_FIR	0x44		
0x44	SYSCTRL2	RW	WAKE	STANDBY				I2S_PIN	WAVDAT_MODE	0x20	
0x49	SYSCTRL7	RW	GAIN_BYPASS					D2S_GAIN		0x04	
0x4A	I2SCFG1	RW	I2SMD		I2SFS		I2SBCK		RX_THRS	0x3A	
0x4B	I2SCFG2	RW				WSINV	BCKINV	CHSEL	I2S_INT	I2S_EN	0x06
0x4C	PWMCFG1	RW	PRC_EN	PRCTIME						0xA0	
0x4D	PWMCFG2	RW				PD_HWM				0x28	
0x4E	PWMCFG3	RW	PR_EN	PRLVL						0xBF	
0x4F	PWMCFG4	RW	PRCTIME						0x32		
0x51	DETCFG1	RW				RL_OS			CLK_ADC	0x02	
0x52	DETCFG2	RW						VBAT_GO	DIAG_GO	0x00	
0x53	DET_RL	RO	RL						0x00		
0x55	DET_VBAT	RO	VBAT						0x00		
0x57	DET_LO	RO	VBAT_LO						RL_LO	0x00	

Register Detailed Description

Note: Reserved register should not be written

SRST: (Address 00h)				
Bit	Symbol	R/W	Description	Default
7:0	CHIPID	RO	All configuration registers will be reset to default value after 0xaa is written	0x06

SYSST: (Address 01h)				
Bit	Symbol	R/W	Description	Default
7:6	Reserved	RO	Not used	0
5	UVLS	RO	1: VBAT voltage is under UV voltage (2.7V)	0
4	FF_AES	RO	1: RTP FIFO is almost empty	1
3	FF_AFS	RO	1: RTP FIFO is almost full	0
2	OCDS	RO	1: Over Current status	0
1	OTS	RO	1: Over Temperature status	0
0	DONES	RO	1: The indication of playback finished	0

SYSINT: (Address 02h)				
Bit	Symbol	R/W	Description	Default
7:6	Reserved	RC	Not used	0
5	UVLI	RC	When UVLI=1, it means UVLS has been 1 at least once since the last read	0
4	FF_AEI	RC	When FF_AEI=1, it means FF_AES has been 1 at least once since the last read	1
3	FF_AFI	RC	When FF_AFI=1, it means FF_AFS has been 1 at least once since the last read	0
2	OCDI	RC	When OCDI=1, it means OCDS has been 1 at least once since the last read	0
1	OTI	RC	When OTI=1, it means OTS has been 1 at least once since the last read	0
0	DONEI	RC	When DONEI=1, it means DONES has been 1 at least once since the last read	0

SYSINTM: (Address 03h)				
Bit	Symbol	R/W	Description	Default
7:6	Reserved	RW	Not used	3
5	UVLM	RW	Interrupt mask for UVLI: 0: INTN pin will be pulled down when UVLI=1 1: INTN pin will not be pulled down when UVLI=1	1

4	FF_AEM	RW	Interrupt mask for FF_AEI: 0: INTN pin will be pulled down when FF_AEI=1 1: INTN pin will not be pulled down when FF_AEI=1	1
3	FF_AFM	RW	Interrupt mask for FF_AFI: 0: INTN pin will be pulled down when FF_AFI=1 1: INTN pin will not be pulled down when FF_AFI=1	1
2	OCDM	RW	Interrupt mask for OCDI: 0: INTN pin will be pulled down when OCDI=1 1: INTN pin will not be pulled down when OCDI=1	1
1	OTM	RW	Interrupt mask for OTI: 0: INTN pin will be pulled down when OTI=1 1: INTN pin will not be pulled down when OTI=1	1
0	DONEM	RW	Interrupt mask for DONEI: 0: INTN pin will be pulled down when DONEI=1 1: INTN pin will not be pulled down when DONEI=1	1

PLAYCFG1: (Address 06h)				
Bit	Symbol	R/W	Description	Default
7	Reserved	RW	Not used	0
6	BST_MODE	RW	BOOST mode 0: Bypass mode 1: boost mode	0
5:0	BST_VOUT_RDA	RW	PVDD voltage setup: default=100000, $\Delta V=78.893\text{mV}$ VBAT should be smaller than $0.8 \times \text{PVDD}$. 000000:6V 000001:6V+ ΔV 000010:6V+ $\Delta V \times 2$ 000011:6V+ $\Delta V \times 3$ 111111:6V+ $\Delta V \times 63$	0x20

PLAYCFG2: (Address 07h)				
Bit	Symbol	R/W	Description	Default
7:0	GAIN	RW	gain setting for waveform data, it is a global setting for all waveform data(except CONT).GAIN=code/128	0x80

PLAYCFG3: (Address 08h)				
Bit	Symbol	R/W	Description	Default
7	Reserved	RW	Not used	0
6	AUTO_BST	RW	1: disable boost when data is 0 in rtp and i2s mode	1
5	STOP_MODE	RW	0: stop when current wave is over; 1: stop right now;	0
4:3	Reserved	RW	Not used	0
2	BRK_EN	RW	when set 1, enable auto brake after RTP/RAM/CONT/I2S playback mode is stopped	1
1:0	PLAY_MODE	RW	waveform play mode for GO trig b00: RAM mode b01: RTP mode b10: CONT mode b11: no play	0

PLAYCFG4: (Address 09h)				
Bit	Symbol	R/W	Description	Default
7:2	Reserved	RW	Not used	0
1	STOP	RW	when set 1, stop the current playback mode	0

0	GO	RW	RAM/RTP/CONT mode playback trig bit when set to 1, chip will playback one of the play mode.	0
---	----	----	--	---

WAVCFG1: (Address 0Ah)				
Bit	Symbol	R/W	Description	Default
7	SEQ1WAIT	RW	when set to 1, WAVSEQ1 means wait time, else means wave sequence number	0
6:0	WAVSEQ1	RW	wait time (code*WAITSLOT) or wave sequence number	1

WAVCFG2: (Address 0Bh)				
Bit	Symbol	R/W	Description	Default
7	SEQ2WAIT	RW	when set to 1, WAVSEQ2 means wait time, else means wave sequence number	0
6:0	WAVSEQ2	RW	wait time (code*WAITSLOT) or wave sequence number	0

WAVCFG3: (Address 0Ch)				
Bit	Symbol	R/W	Description	Default
7	SEQ3WAIT	RW	when set to 1, WAVSEQ3 means wait time, else means wave sequence number	0
6:0	WAVSEQ3	RW	wait time (code*WAITSLOT) or wave sequence number	0

WAVCFG4: (Address 0Dh)				
Bit	Symbol	R/W	Description	Default
7	SEQ4WAIT	RW	when set to 1, WAVSEQ4 means wait time, else means wave sequence number	0
6:0	WAVSEQ4	RW	wait time or wave sequence number	0

WAVCFG5: (Address 0Eh)				
Bit	Symbol	R/W	Description	Default
7	SEQ5WAIT	RW	when set to 1, WAVSEQ5 means wait time, else means wave sequence number	0
6:0	WAVSEQ5	RW	wait time (code*WAITSLOT) or wave sequence number	0

WAVCFG6: (Address 0Fh)				
Bit	Symbol	R/W	Description	Default
7	SEQ6WAIT	RW	when set to 1, WAVSEQ6 means wait time, else means wave sequence number	0
6:0	WAVSEQ6	RW	wait time (code*WAITSLOT) or wave sequence number	0

WAVCFG7: (Address 10h)				
Bit	Symbol	R/W	Description	Default
7	SEQ7WAIT	RW	when set to 1, WAVSEQ7 means wait time, else means wave sequence number	0
6:0	WAVSEQ7	RW	wait time (code*WAITSLOT) or wave sequence number	0

WAVCFG8: (Address 11h)				
Bit	Symbol	R/W	Description	Default
7	SEQ8WAIT	RW	when set to 1, WAVSEQ8 means wait time, else means wave sequence number	0
6:0	WAVSEQ8	RW	wait time (code*WAITSLOT) or wave sequence number	0

WAVCFG9: (Address 12h)				
Bit	Symbol	R/W	Description	Default
7:4	SEQ1LOOP	RW	control the loop number of the first sequence b0000~b1110: play (code+1) time b1111: playback infinitely until STOP set to 1 or SEQ1LOOP ≠ 0xF	0
3:0	SEQ2LOOP	RW	control the loop number of the second sequence b0000~b1110: play (code+1) time b1111: playback infinitely until STOP set to 1 or SEQ2LOOP ≠ 0xF	0

WAVCFG10: (Address 13h)				
Bit	Symbol	R/W	Description	Default
7:4	SEQ3LOOP	RW	control the loop number of the third sequence b0000~b1110: play (code+1) time b1111: playback infinitely until STOP set to 1 or SEQ3LOOP ≠ 0xF	0
3:0	SEQ4LOOP	RW	control the loop number of the fourth sequence b0000~b1110: play (code+1) time b1111: playback infinitely until STOP set to 1 or SEQ4LOOP ≠ 0xF	0

WAVCFG11: (Address 14h)				
Bit	Symbol	R/W	Description	Default
7:4	SEQ5LOOP	RW	control the loop number of the fifth sequence b0000~b1110: play (code+1) time b1111: playback infinitely until STOP set to 1 or SEQ5LOOP ≠ 0xF	0
3:0	SEQ6LOOP	RW	control the loop number of the sixth sequence b0000~b1110: play (code+1) time b1111: playback infinitely until STOP set to 1 or SEQ6LOOP ≠ 0xF	0

WAVCFG12: (Address 15h)				
Bit	Symbol	R/W	Description	Default
7:4	SEQ7LOOP	RW	control the loop number of the seventh sequence b0000~b1110: play (code+1) time b1111: playback infinitely until STOP set to 1 or SEQ7LOOP ≠ 0xF	0
3:0	SEQ8LOOP	RW	control the loop number of the eighth sequence b0000~b1110: play (code+1) time b1111: playback infinitely until STOP set to 1 or SEQ8LOOP ≠ 0xF	0

WAVCFG13: (Address 16h)				
Bit	Symbol	R/W	Description	Default
7	Reserved	RW	Not used	0
6:5	WAITSLLOT	RW	unit of wait time b00: (1/WAVDAT_MODE) s b01: (8/WAVDAT_MODE) s b10: (64/WAVDAT_MODE) s b11: (512/WAVDAT_MODE) s	0
4	Reserved	RW	Not used	0
3:0	MAINLOOP	RW	control the main loop number b0000~b1110: play (code+1) time b1111: playback infinitely until STOP set to 1 or MAINLOOP ≠ 0xF	0

CONTCFG1: (Address 18h)				
Bit	Symbol	R/W	Description	Default
7:4	EDGE_FRE	RW	define the edge frequency 1000 : 200Hz 1001 : 300Hz 1010 : 400Hz 1011 : 500Hz 1100 : 600Hz 1101 : 700Hz 1110 : 800Hz 1111 : 900Hz 0XXX : no edge control	13

3	EN_F0_DET	RW	f0 detection mode enable 1: enable 0: disable	0
2	Reserved	RW	Not used	0
1	BRK_BST_MD	RW	when set 1, brake is the same with current playback mode (boost or bypass) otherwise brake is bypass mode	0
0	SIN_MODE	RW	edge mode 1: cos 0: sine	1

CONTCFG2: (Address 19h)				
Bit	Symbol	R/W	Description	Default
7:0	F_PRE	RW	set the value of F0, $F0=(24K/code)Hz$	0x8D

CONTCFG3: (Address 1Ah)				
Bit	Symbol	R/W	Description	Default
7:0	DRV_WIDTH	RW	half cycle drive time of brake, this value must be smaller than half cycle time of F0. Time = code/48000 (s)	0x6A

CONTCFG5: (Address 1Ch)				
Bit	Symbol	R/W	Description	Default
7:4	BST_BRK_GAIN	RW	gain factor of brake when BST_MODE is 1	5
3:0	BRK_GAIN	RW	gain factor of brake when BST_MODE is 0	8

CONTCFG6: (Address 1Dh)				
Bit	Symbol	R/W	Description	Default
7	TRACK_EN	RW	track switch 1: enable 0: disable	1
6:0	DRV1_LVL	RW	level for the first cont drive. When VBAT_MODE=1: no load output voltage= $(3.05*DRV1_LVL/128)*(PVDD/VBAT)$; if $(3.05*DRV1_LVL)/VBAT > 128$, no load output voltage=PVDD; When VBAT_MODE=0: no load output voltage= $PVDD*DRV1_LVL/128$	0x7F

CONTCFG7: (Address 1Eh)				
Bit	Symbol	R/W	Description	Default
7	Reserved	RW	Not used	0
6:0	DRV2_LVL	RW	level for the second cont drive. When VBAT_MODE=1: no load output voltage= $(3.05*DRV2_LVL/128)*(PVDD/VBAT)$; if $(3.05*DRV2_LVL)/VBAT > 128$, no load output voltage=PVDD; When VBAT_MODE=0: no load output voltage= $PVDD*DRV2_LVL/128$	0x50

CONTCFG8: (Address 1Fh)				
Bit	Symbol	R/W	Description	Default
7:0	DRV1_TIME	RW	number of half cycle for the first cont drive	4

CONTCFG9: (Address 20h)				
Bit	Symbol	R/W	Description	Default
7:0	DRV2_TIME	RW	number of half cycle for the second cont drive.	6

CONTCFG10: (Address 21h)				
Bit	Symbol	R/W	Description	Default
7:0	BRK_TIME	RW	the num of half cycle of brake mode	8

CONTCFG11: (Address 22h)				
Bit	Symbol	R/W	Description	Default
7:0	TRACK_MARGIN	RW	margin value of tracking, the smaller margin, the higher tracking accuracy and the lower loop stability. Time = code/48000 (s)	12

CONTRD14: (Address 25h)				
Bit	Symbol	R/W	Description	Default
7:0	F_LRA_F0_H	RO	High 8 bit of the measure value for the f0 of LRA in the f0 detection mode $F0=(384000/(F_LRA_F0_H*256+F_LRA_F0_L))Hz$	0

CONTRD15: (Address 26h)				
Bit	Symbol	R/W	Description	Default
7:0	F_LRA_F0_L	RO	Low 8 bit of the measure value for the f0 of LRA in the f0 detection mode $F0=(384000/(F_LRA_F0_H*256+F_LRA_F0_L))Hz$	0

CONTRD16: (Address 27h)				
Bit	Symbol	R/W	Description	Default
7:0	CONT_F0_H	RO	The measure value for the f0 of LRA in the continuous detection mode (high eight bits) $F0=(384000/(CONT_F0_H*256+CONT_F0_L))Hz$	0

CONTRD17: (Address 28h)				
Bit	Symbol	R/W	Description	Default
7:0	CONT_F0_L	RO	The measure value for the f0 of LRA in the continuous detection mode (low eight bits) $F0=(384000/(CONT_F0_H*256+CONT_F0_L))Hz$	0

RTPCFG1: (Address 2Dh)				
Bit	Symbol	R/W	Description	Default
7:6	Reserved	RW	Not used	0
5:0	BASE_ADDR_H	RW	High six bits of start address of wave SRAM $BASE_ADDR = BASE_ADDR_H * 256 + BASE_ADDR_L$	0x08

RTPCFG2: (Address 2Eh)				
Bit	Symbol	R/W	Description	Default
7:0	BASE_ADDR_L	RW	Low eight bits of start address of wave SRAM $BASE_ADDR = BASE_ADDR_H * 256 + BASE_ADDR_L$	0

RTPCFG3: (Address 2Fh)				
Bit	Symbol	R/W	Description	Default
7:4	FIFO_AEH	RW	High four bits of RTP FIFO almost empty threshold $FIFO_AE = FIFO_AEH * 256 + FIFO_AEL$	0x02
3:0	FIFO_AFH	RW	High four bits of RTP FIFO almost full threshold $FIFO_AF = FIFO_AFH * 256 + FIFO_AFL$	0x06

RTPCFG4: (Address 30h)				
Bit	Symbol	R/W	Description	Default
7:0	FIFO_AEL	RW	Low eight bits of RTP FIFO almost empty threshold $FIFO_AE = FIFO_AEH * 256 + FIFO_AEL$	0x00

RTPCFG5: (Address 31h)				
Bit	Symbol	R/W	Description	Default
7:0	FIFO_AFL	RW	Low eight bits of RTP FIFO almost full threshold FIFO_AF = FIFO_AFH * 256 + FIFO_AFL	0x00

RTPDATA: (Address 32h)				
Bit	Symbol	R/W	Description	Default
7:0	RTP_DATA	RW	RTP mode , data write entry, when data written into this register, the data will be written into RTP FIFO	0

TRGCFG1: (Address 33h)				
Bit	Symbol	R/W	Description	Default
7	TRG1_POS	RW	trg1 rising edge enable/disable control 1: enable 0: disable	0
6:0	TRG1SEQ_P	RW	trg1 posedge triggered wave sequence number	1

TRGCFG2: (Address 34h)				
Bit	Symbol	R/W	Description	Default
7	TRG2_POS	RW	trg2 rising edge enable/disable control 1: enable 0: disable	0
6:0	TRG2SEQ_P	RW	trg2 posedge triggered wave sequence number	1

TRGCFG3: (Address 35h)				
Bit	Symbol	R/W	Description	Default
7	TRG3_POS	RW	trg3 rising edge enable/disable control 1: enable 0: disable	0
6:0	TRG3SEQ_P	RW	trg3 posedge triggered wave sequence number	1

TRGCFG4: (Address 36h)				
Bit	Symbol	R/W	Description	Default
7	TRG1_NEG	RW	trg1 falling edge enable/disable control 1: enable 0: disable	0
6:0	TRG1SEQ_N	RW	trg1 negedge triggered wave sequence number	1

TRGCFG5: (Address 37h)				
Bit	Symbol	R/W	Description	Default
7	TRG2_NEG	RW	trg2 falling edge enable/disable control 1: enable 0: disable	0
6:0	TRG2SEQ_N	RW	trg2 negedge triggered wave sequence number	1

TRGCFG6: (Address 38h)				
Bit	Symbol	R/W	Description	Default
7	TRG3_NEG	RW	trg3 falling edge enable/disable control 1: enable 0: disable	0
6:0	TRG3SEQ_N	RW	trg3 negedge triggered wave sequence number	1

TRGCFG7: (Address 39h)				
Bit	Symbol	R/W	Description	Default
7	TRG1_POLAR	RW	TRIG1 pin active polarity, when host supply positive level, this bit set to 0, else set to 1	0

6	TRG1_LEV	RW	trg1 mode control 1: level 0: edge	0
5	TRG1_BRK	RW	when set 1, enable auto brake after TRG1 playback mode is stopped	1
4	TRG1_BST	RW	when set 1, enable boost in TRG1 playback mode.	1
3	TRG2_POLAR	RW	TRIG2 pin active polarity, when host supply positive level, this bit set to 0, else set to 1	0
2	TRG2_LEV	RW	trg2 mode control 1: level 0: edge	0
1	TRG2_BRK	RW	when set 1, enable auto brake after TRG2 playback mode is stopped	1
0	TRG2_BST	RW	when set 1, enable boost in TRG2 playback mode.	1

TRGCFG8: (Address 3Ah)				
Bit	Symbol	R/W	Description	Default
7	TRG3_POLAR	RW	TRIG3 pin active polarity, when host supply positive level, this bit set to 0, else set to 1	0
6	TRG3_LEV	RW	trg3 mode control 1: level 0: edge	0
5	TRG3_BRK	RW	when set 1, enable auto brake after TRG3 playback mode is stopped	1
4	TRG3_BST	RW	when set 1, enable boost in TRG3 playback mode.	1
3	TRG_ONEWIRE	RW	when set 1,enable one wire mode	0
2	TRG1_STOP	RW	when set 1, TRG1 playback mode can be stopped immediately	0
1	TRG2_STOP	RW	when set 1, TRG2 playback mode can be stopped immediately	0
0	TRG3_STOP	RW	when set 1, TRG3 playback mode can be stopped immediately	0

GLBCFG2: (Address 3Ch)				
Bit	Symbol	R/W	Description	Default
7:0	START_DLY	RW	Startup delay time, unit time is (1/48k)s.	0x01

GLBCFG4: (Address 3Eh)				
Bit	Symbol	R/W	Description	Default
7:6	GO_Prio	RW	Priority value of GO TRIG High priority can interrupt the playback of low priority, and low priority cannot interrupt the playback of high priority. When the priority settings are consistent, the default priority will be implemented	0
5:4	TRG3_Prio	RW	Priority value of TRIG3 pin High priority can interrupt the playback of low priority, and low priority cannot interrupt the playback of high priority. When the priority settings are consistent, the default priority will be implemented	1
3:2	TRG2_Prio	RW	Priority value of TRIG2 pin High priority can interrupt the playback of low priority, and low priority cannot interrupt the playback of high priority. When the priority settings are consistent, the default priority will be implemented	2
1:0	TRG1_Prio	RW	Priority value of TRIG1 pin High priority can interrupt the playback of low priority, and low priority cannot interrupt the playback of high priority. When the priority settings are consistent, the default priority will be implemented	3

GLBRD5: (Address 3Fh)				
Bit	Symbol	R/W	Description	Default
7:4	Reserved	RO	Not used	0
3:0	GLB_STATE	RO	The state of glb state 0000: STANDBY 0110: CONT 0111: RAM	0

			1000: RTP 1001: TRIG 1010: I2S 1011: BRAKE	
--	--	--	---	--

RAMADDRH: (Address 40h)				
Bit	Symbol	R/W	Description	Default
7:6	Reserved	RWS	Not used	0
5:0	RAMADDRH	RWS	SRAM address high six bits	0

RAMADDRL: (Address 41h)				
Bit	Symbol	R/W	Description	Default
7:0	RAMADDRL	RWS	SRAM address low eight bits	0

RAMDATA: (Address 42h)				
Bit	Symbol	R/W	Description	Default
7:0	RAMDATA	RWS	SRAM data entry	0

SYSCTRL1: (Address 43h)				
Bit	Symbol	R/W	Description	Default
7	VBAT_MODE	RW	VBAT adjust mode, 0: software adjust mode, 1: hardware adjust mode	0
6	Reserved	RW	Not used	1
5:4	Reserved	RW	Not used	0
3	EN_RAMINIT	RW	Enable internal OSC clk After powerup, system should initial SRAM for preload effects, to do so, this bit must be set to 1	0
2	EN_FIR	RW	set enable of FIR filter	1
1:0	Reserved	RW	Not used	0

SYSCTRL2: (Address 44h)				
Bit	Symbol	R/W	Description	Default
7	WAKE	RW	Chip enable control 1: set chip into active mode	0
6	STANDBY	RW	Chip disable control 1: set chip into standby mode	0
5:4	Reserved	RW	Not used	2
3	Reserved	RW	Not used	0
2	I2S_PIN	RW	when this reg is set to 1, TRIG3 PIN is used as I2S DATA1, TRIG2 PIN is used as I2S WCK	0
1:0	WAVDAT_MODE	RW	waveform data upsample rate selection: 1: 48kHz 0: 24kHz others: 12kHz rate	0

SYSCTRL7: (Address 49h)				
Bit	Symbol	R/W	Description	Default
7	Reserved	RW	Not used	0
6	GAIN_BYPASS	RW	1: gain can be changed when playing 0: gain can not be changed when playing	0
5:3	Reserved	RW	Not used	0

2:0	D2S_GAIN	RW	Set D2S gain 000: 1 001: 2 010: 4 011: 8 100: 10 101: 16 110: 20 111: 26.7	4
-----	----------	----	--	---

I2SCFG1: (Address 4Ah)				
Bit	Symbol	R/W	Description	Default
7:6	I2SMD	RW	I2S interface mode 00: Philip standard I2S (default) 11: Philip standard I2S 01: MSB justified 10: LSB justified	0
5:4	I2SFS	RW	I2S data width selection BCK=(64*fs) (48*fs) (32*fs) 00: 16 bits 16 bits 16 bits 01: 20 bits 20 bits 16 bits 10: 24 bits 24 bits 16 bits 11: 32 bits 24 bits 16 bits	3
3:2	I2SBCK	RW	I2S BCK mode 00: 32*fs(16*2) RCK = 1.536MHz/1.4112MHz 01: 48*fs(24*2) RCK = 2.304MHz/2.1168MHz 10: 64*fs(32*2) RCK = 3.072MHz/2.8224MHz 11: Reserved	2
1:0	RX_THRS	RW	I2S receiver channel FIFO almost full threshold (RX_THRS+1) 0 to 3, default: 2	2

I2SCFG2: (Address 4Bh)				
Bit	Symbol	R/W	Description	Default
7:5	Reserved	RW	Not used	0
4	WSINV	RW	I2S Left/Right channel switch 0: No switch 1: Left/Right switch	0
3	BCKINV	RW	I2S bit clock invert control 0: not invert 1: inverted	0
2	CHSEL	RW	Left/right channel selection for I2S input 1: right 0: left	1
1	I2S_INT	RW	1: i2s mode can be interrupted 0: i2s mode can not be interrupted	1
0	I2S_EN	RW	1: enable i2s 0: disable i2s	0

PWMCFG1: (Address 4Ch)				
Bit	Symbol	R/W	Description	Default
7	PRC_EN	RW	Set enable of output signal protection mode of pwm: 0: disable 1: When HDP/HDN output voltage $\geq 124/128 * PVDD$ maintains (PRCTIME/3k)s, HDP/HDN is pulled down protectively	1
6:0	PRCTIME	RW	set protection time of output signal protection mode of pwm, unit time is (1/3k) s.	0x20

PWMCFG2: (Address 4Dh)				
Bit	Symbol	R/W	Description	Default
7:5	reserved	RW	Not used	1
4	PD_HWM	RW	shutdown half wave modulate 0: half wave mode 1: full wave mode	0
3:0	reserved	RW	Not used	8

PWMCFG3: (Address 4Eh)				
Bit	Symbol	R/W	Description	Default
7	PR_EN	RW	Set enable of input signal protection mode of pwm: 0: disable 1: When output voltage \geq PRLVL/128*PVDD maintains (PRTIME/3k)s, HDP/HDN is pulled down protectively	1
6:0	PRLVL	RW	set protection voltage of input signal protection mode of pwm	0x3F

PWMCFG4: (Address 4Fh)				
Bit	Symbol	R/W	Description	Default
7:0	PRTIME	RW	set protection time of input signal protection mode of pwm, unit time is (1/3k) s.	0x32

DETCFG1: (Address 51h)				
Bit	Symbol	R/W	Description	Default
7:5	Reserved	RW	Not used	0
4	RL_OS	RW	Set diagnostic mode 1:RL 0:OS	0
3	Reserved	RW	Not used	0
2:0	CLK_ADC	RW	Set frequency of ADC clock 000: 12Mhz 001: 6Mhz 010: 3Mhz 011: 1.5Mhz 100: 0.75Mhz 101: 0.375Mhz 110: 0.1875Mhz 111: 0.09375Mhz	2

DETCFG2: (Address 52h)				
Bit	Symbol	R/W	Description	Default
7:2	Reserved	RW	Not used	0
1	VBAT_GO	RW	Set the enabled of VBAT mode	0
0	DIAG_GO	RW	Set the enabled of DIAG mode	0

DET_RL: (Address 53h)				
Bit	Symbol	R/W	Description	Default
7:0	RL	RO	the Measured value of resistance of LRA in DIAG mode(high eight bits) RL=code*678/(1024*d2s_gain) (Ω)	0

DET_VBAT: (Address 55h)				
Bit	Symbol	R/W	Description	Default
7:0	VBAT	RO	the Measured value of VBAT in VBAT mode(high eight bits) VBAT=code*6.1/1024 (V)	0

DET_LO: (Address 57h)				
Bit	Symbol	R/W	Description	Default
7:6	Reserved	RO	Not used	0
5:4	VBAT_LO	RO	the Measured value of VBAT in VBAT mode(low two bits) VBAT=code*6.1/1024 (V)	0
3:2	Reserved	RO	Not used	0
1:0	RL_LO	RO	the Measured value of resistance of LRA in DIAG mode(low two bits) RL=code*678/(1024*d2s_gain) (Ω)	0

Application Information

Inductor Selection Guideline

Selecting inductor needs to consider Inductance, size, magnetic shielding, saturation current and temperature current.

a) Inductance

Inductance value is limited by the boost converter's internal loop compensation. In order to ensure phase margin sufficient under all operating conditions, recommended 1μH inductor.

b) Size

For a certain value of inductor, the smaller the size, the greater the parasitic series resistance of the inductor DCR, the higher the loss, corresponds to the lower efficiency.

c) Magnetic shielding

Magnetic shielding can effectively prevent the inductance of the electromagnetic radiation interference. It is much better to choose inductance with magnetic shielding in the application of EMI sensitive environment.

d) Saturation current and temperature rise of current

Inductor saturation current and temperature rise current value are important basis for selecting the inductor. As the inductor current increases, on the one hand, since the magnetic core begins to saturate, inductance value will decline; on the other hand, the inductor's parasitic resistance inductance and magnetic core loss can lead to temperature rise. In general, the current value is defined as the saturation current I_{SAT} when the inductance value drops to 70%; the current value is defined as temperature rise current I_{RMS} when inductance temperature rise 40°C.

For particular applications, need to calculate the maximum I_{L_PEAK} and I_{L_RMS} , which is a basis of selecting the inductor. When $V_{BAT}=3.8V$, $PVDD=8.5V$, $R_L = 8\Omega$, Output drive $R_{DS(on)} = 300m\Omega$, when the maximum power without distortion, the output power is calculated as follows:

$$P_{OUT} = \frac{(V_{OUT} \times \frac{R_L}{R_L + R_{DS(on)}})^2}{2 \times R_L \times (1 - 2.3\%)} = \frac{(8.5 \times \frac{8}{8 + 0.3})^2}{2 \times 8 \times 0.977} W = 4.294W$$

Where the coefficients in the denominator of (0.977) is the power ratio of no truncation maximum output. In such a large output power, the overall efficiency of the output drive is typically 75%, in order to calculate the maximum average current $I_{MAX_AVG_VBAT}$ and maximum peak current $I_{MAX_PEAK_VBAT}$ drawn from VBAT:

$$I_{MAX_AVG_VBAT} = \frac{P_{OUT}}{VBAT \times \eta} = \frac{4.294}{3.8 \times 0.75} A = 1.507A$$

$$I_{MAX_PEAK_VBAT} = 2 \times I_{MAX_AVG_VBAT} = 2 \times 1.507A = 3.014A$$

If inductor DCR is 50mΩ, then when the output power of 4.294W, the inductor power loss is:

$$P_{DCR_LOSS} = 1.5 \times I_{MAX_AVG_VBAT}^2 \times DCR = 1.5 \times 1.507^2 \times 0.05 W = 170.3 mW$$

Wherein the coefficient 1.5 is the square of the ratio of the sine wave current RMS value and average value (there is no consideration of the impact of the inductor ripple, the actual DCR loss will be even greater). If the loss which is resulting from DCR is less than 1% at efficiency ($P_{OUT} = 4.294W$, $\eta = 75\%$), then:

$$DCR = \frac{P_{DCR,LOSS}}{1.5 \times I_{MAX_AVG_VBAT}^2} \leq 0.01 \times \frac{P_{OUT}}{1.5 \times I_{MAX_AVG_VBAT}^2 \times \eta} = \frac{0.01 \times 4.294}{1.5 \times 1.507^2 \times 0.75} \Omega = 16.8 \text{ m}\Omega$$

According to the working principle of the Boost, we can calculate the size of the inductor current ripple ΔI_L :

$$\Delta I_L = \frac{VBAT \times (PVDD - VBAT)}{PVDD \times f \times L} = \frac{3.8 \times (8.5 - 3.8)}{8.5 \times 1.6 \times 1} A = 1.31A$$

Thus, the maximum peak inductor current I_{L_PEAK} and maximum effective inductor current I_{L_RMS} is:

$$I_{L_PEAK} = I_{MAX_PEAK_VBAT} + \frac{\Delta I_L}{2} = 3.014 + \frac{1.31}{2} A = 3.669A$$

$$I_{L_RMS} = \sqrt{I_{MAX_PEAK_VBAT}^2 + \frac{\Delta I_L^2}{12}} = \sqrt{3.014^2 + \frac{1.31^2}{12}} A = 3.038A$$

From the above calculation results:

- 1) For typical DCR about 50mΩ inductance, the efficiency loss caused by around 3%;
- 2) Need to choose AW86917 inductance input current limit value I_{LIMIT} is greater than $I_{L_PEAK} = 3.6A$ ($I_{LIMIT} = 4.2A$), to guarantee the output drive power can be achieved when THD = 1% (= 4.1W) but not limited by value I_{LIMIT} ; If you choose I_{SAT} or I_{RMS} of the inductance is too small, it is possible to cause the chip don't work properly, or the temperature of the inductance is too high.
- 3) In practice, the maximum output power of the drive is likely to reach 4.3W in an instant, so the selected inductor saturation current I_{SAT} requires more than the maximum inductor peak current I_{L_PEAK} , and cannot be less than 3.6A;
- 4) In some cases, if the I_{L_PEAK} calculated according to the above method is greater than the set of input inductor current limit value I_{LIMIT} , shows the output drive is restricted by inductance input current limit, the actual maximum output power is less than the calculated value, the measured value shall prevail, and I_{SAT} need greater than the set current limiting value I_{LIMIT} , and cannot be less than 3.6A;
- 5) Take PVDD = 8.5V for example, under different conditions, the typical method of selecting I_{SAT} in the following table:

VBAT (V)	PVDD (V)	RL (Ω)	IL_PEAK (A)	Inductor saturation current ISAT minimum value (A)
3.8	8.5	8	3.7	4.2
3.8	8.5	16	2.3	2.5

Capacitors Selection

Boost Capacitor Selection

Boost output capacitor is usually within the range 0.1μF~47μF. It needs to use Class II type (EIA) multilayer ceramic capacitors (MLCC). Its internal dielectric is ferroelectric material (typically BaTiO₃), a high the dielectric constant in order to achieve smaller size, but at the same Class II type (EIA) multilayer ceramic capacitors has poor temperature stability and voltage stability as compared to the Class I type (EIA) capacitance. Capacitor is selected based on the requirements of temperature stability and voltage stability, considering the capacitance material, capacitor voltage, and capacitor size and capacitance values.

A) temperature stability

Class II capacitance have different temperature stability in different materials, usually choose X5R type in order to ensure enough temperature stability, and X7R type capacitance has better properties, the price is relatively more expensive; X5R capacitance change within ± 15% in temperature range of -55°C to 85°C, X7R capacitance change within ±15% in temperature range of -55°C~125°C. The Boost output capacitance of AW86917 recommends X5R ceramic capacitors.

B) Voltage Stability

Class II type capacitor has poor voltage stability Capacitance values falling fast along with the DC bias voltage applied across the capacitor increasing. The rate of decline is related to capacitance material, capacitors rated voltage, capacitance volume. Take for TDK C series X5R for example, its pressure voltage value is 16V or 25V; the package size is 0805, 1206 or 0603, the capacitance value is 10 μ F. The capacitor's voltage stability of different types of capacitor is as shown below:

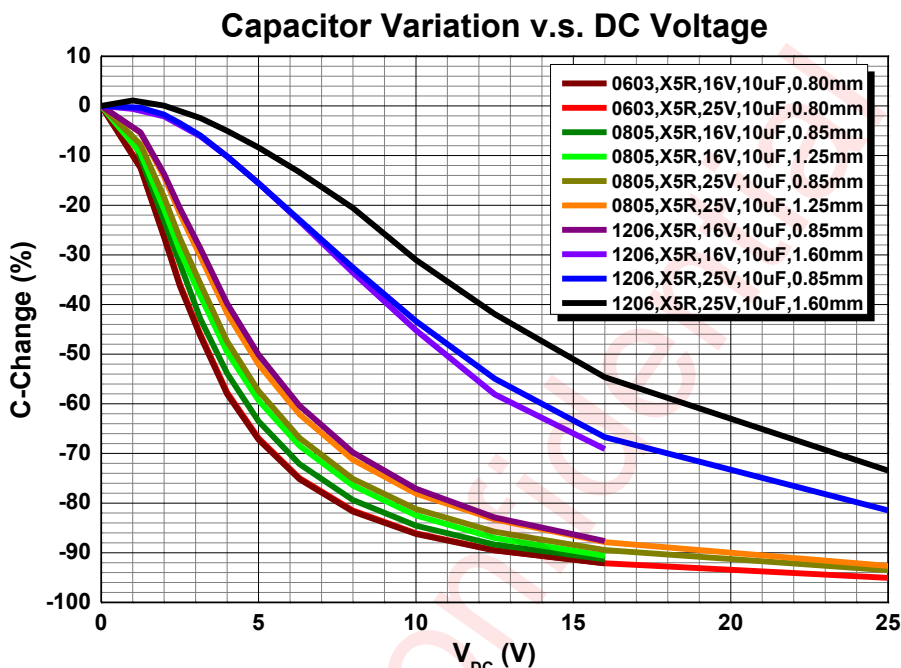

Figure 34 Different types of capacitive voltage stability

Among them, the space remaining value of different types of capacitors at V_{DC} = 8.5 V as shown in the Figure 35:

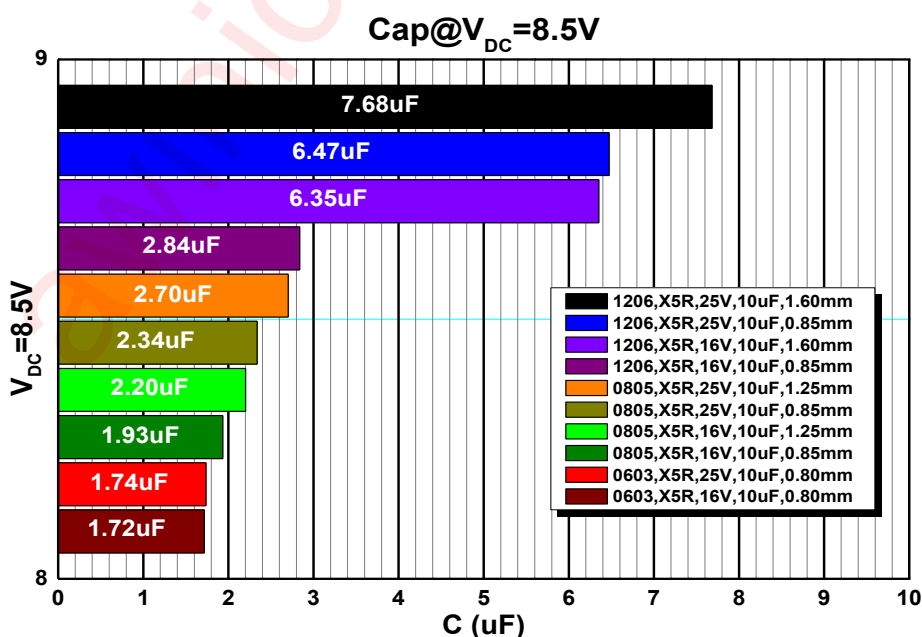

Figure 35 The space remaining value of different types of capacitors at V_{DC} = 8.5 V

It can be found that the rate of capacitance capacity value descent becomes slow along with "large capacitor size, capacitance pressure voltage rise". The larger the package size, the better voltage stability. The higher the height, the better voltage stability with the same length and width of the capacitance. Voltage stability of smaller package size (0603) capacitor change affected by the pressure value is very small.

In AW86917 typical applications, it is necessary to ensure the output value of the Boost capacitor $\geq 5\mu\text{F}$ when $\text{PVDD}=8.5\text{V}$.

Supply Decoupling Capacitor (C_S)

The device is a high voltage driver that requires adequate power supply decoupling. Place a low equivalent-series-resistance (ESR) ceramic capacitor, typically $0.1\mu\text{F}$. This choice of capacitor and placement helps with higher frequency transients, spikes, or digital hash on the line. Additionally, placing this decoupling capacitor close to the device is important, as any parasitic resistance or inductance between the device and the capacitor causes efficiency loss. In addition to the $0.1\mu\text{F}$ ceramic capacitor, place a $10\mu\text{F}$ capacitor on the VBAT supply trace. This larger capacitor acts as a charge reservoir, providing energy faster than the board supply, thus helping to prevent any droop in the supply voltage.

Output beads, capacitors

The device output is a square wave signal, which causing switch current at the output capacitor, increasing static power consumption, and therefore output capacitor should not be too large, 0.1nF ceramic capacitors is recommended.

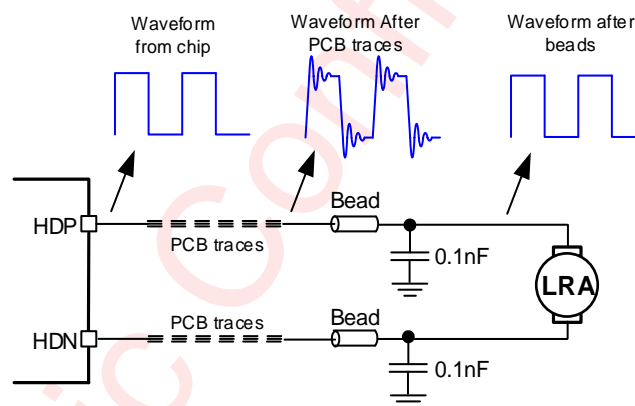

Figure 36 Ferrite Chip Bead and capacitor

The device output is a square wave signal. The voltage across the capacitor will be much larger than the PVDD voltage after increasing the bead capacitor. It suggested the use of rated voltage above 16V capacitor. At the same time a square wave signal at the output capacitor switching current form, the static power consumption increases, so the output capacitance should not be too much which is recommended 0.1nF ceramic capacitor rated voltage of 16V .

PCB Layout Consideration

Layout Considerations

This device is a high voltage driver chip. To obtain the optimal performance, PCB layout should be considered carefully. The suggested Layout is illustrated in the following diagram:

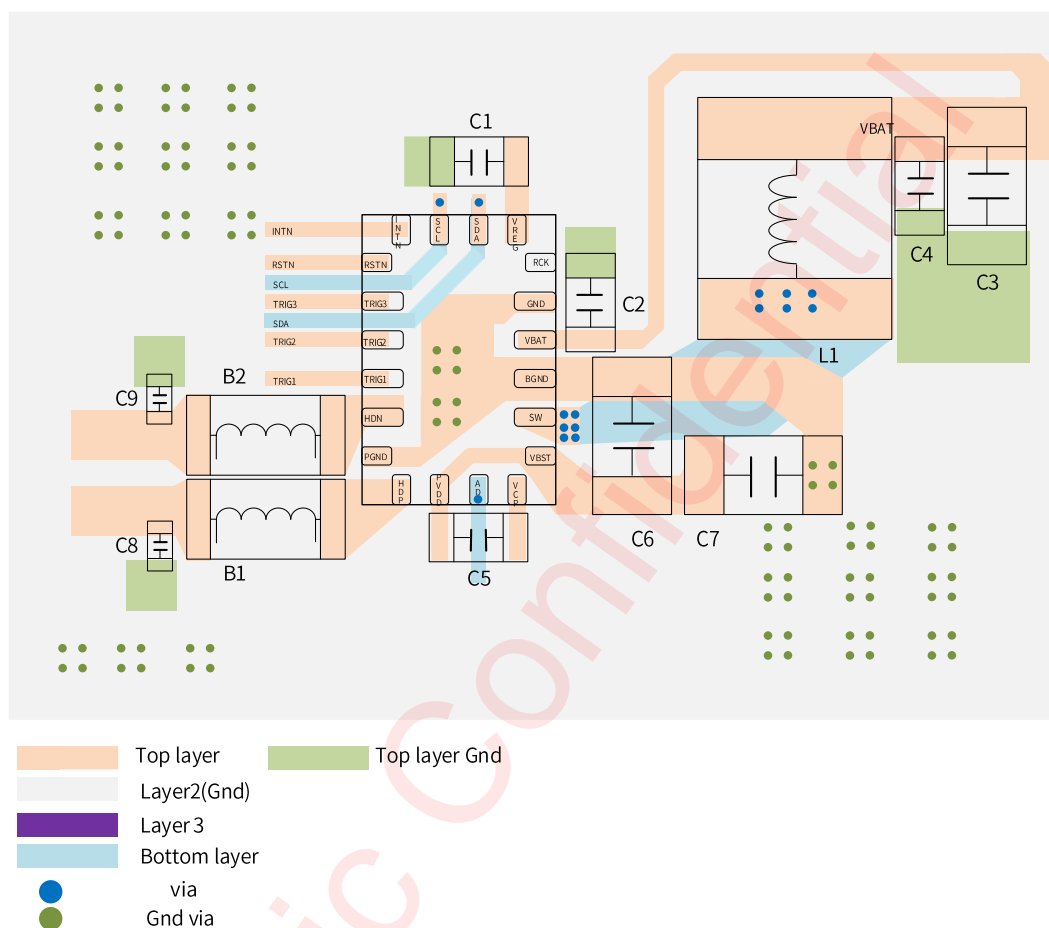
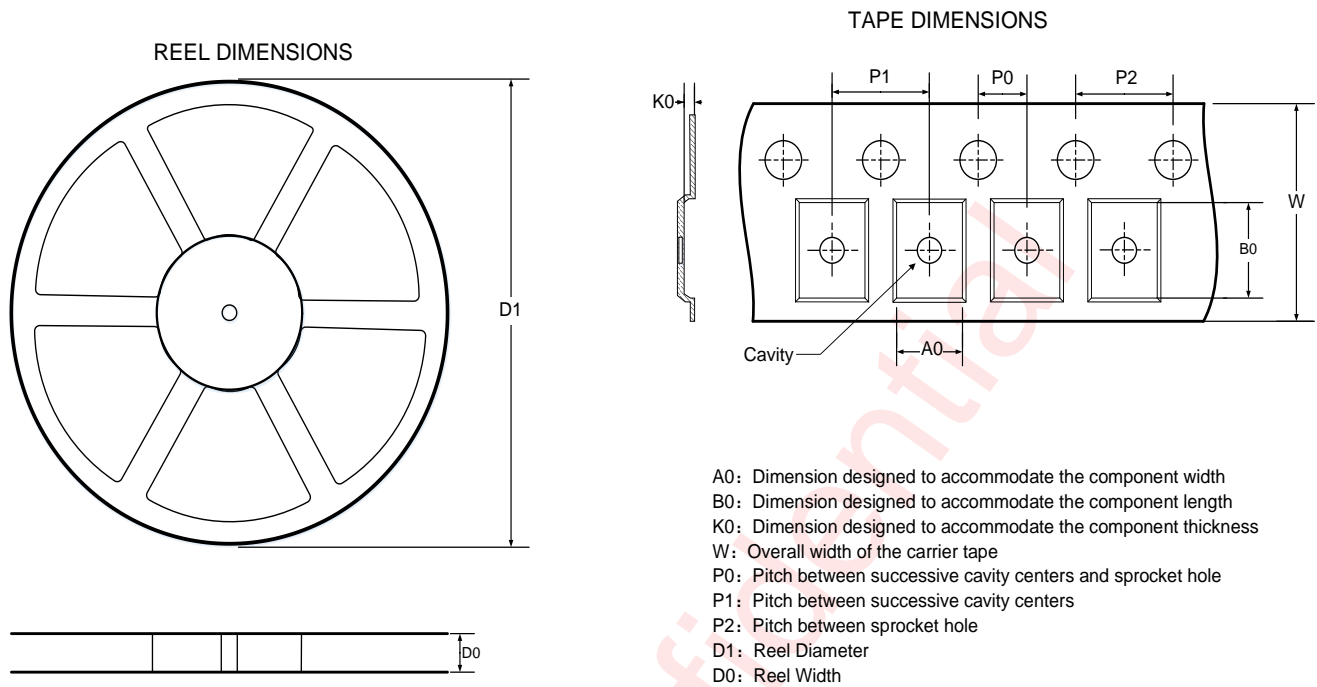

Figure 37 AW86917 Board Layout

Here are some guidelines:

1. All of the external components should be placed as close as possible to IC in top layer PCB.
2. SCL and SDA should be shield by ground.
3. The overcurrent capability of the VBAT to SW should meet $I_{MAX_PEAK_VBAT}$, and C2, C3, C4 should be placed close to IC and L1.
4. C6 and C7 are within 1.5mm to pin PVDD or pin VBST, and the overcurrent capability of the VBST and PVDD traces must be meet $\frac{PVDD}{R_L + R_{DS(ON)}}$, and the GND side of the PVDD capacitor should be directly connected to surface layer ground or punched to the main ground of the PCB. In addition, create solid GND plane near and around the IC, connect BGND, PGND and GND together, and the overcurrent capability of the vias should be designed according to the PVDD overcurrent capability.
5. Routing overcurrent capability of HDP/HDN output to the load should meet $\frac{PVDD}{R_L + R_{DS(ON)}}$. HDP and HDN should be shield by ground and far away from the interference source especially the FLY capacitor of the high-power charging IC, otherwise it will cause the abnormal F0 detection.

Tape And Reel Information



QUADRANT ASSIGNMENTS FOR PIN 1 ORIENTATION IN TAPE

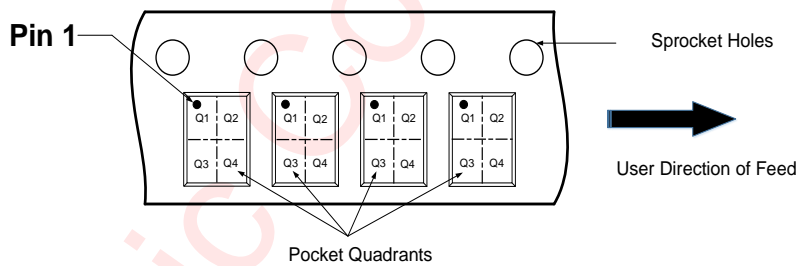

DIMENSIONS AND PIN 1 ORIENTATION

D1 (mm)	D0 (mm)	A0 (mm)	B0 (mm)	K0 (mm)	P0 (mm)	P1 (mm)	P2 (mm)	W (mm)	Pin1 Quadrant
330	12.4	2.3	3.3	0.75	2	4	4	12	Q1

All dimensions are nominal

Package Description

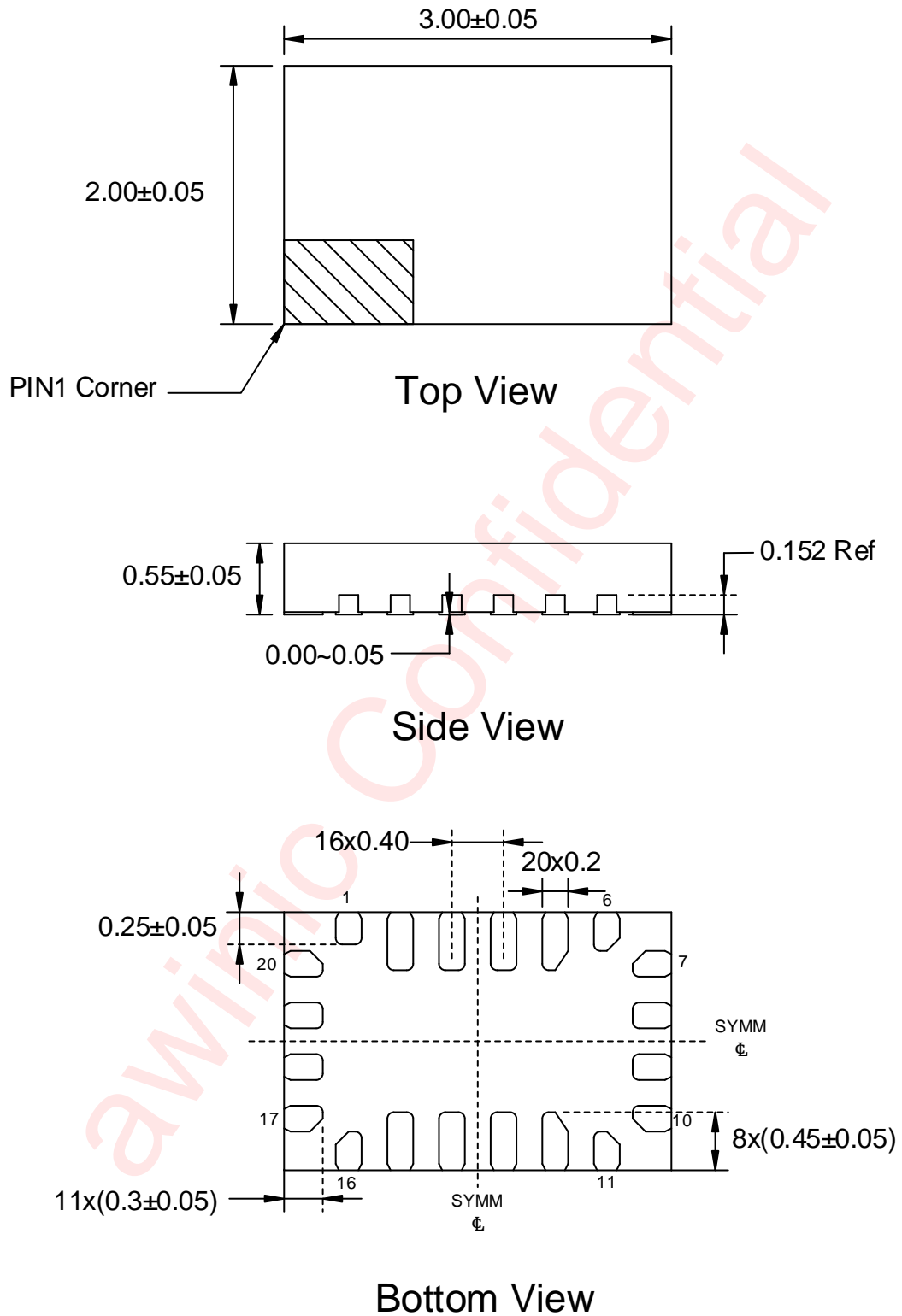

Unit: mm

Land Pattern Data

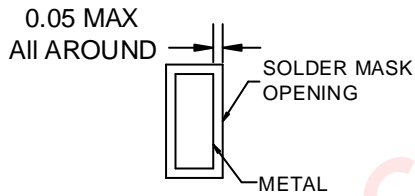
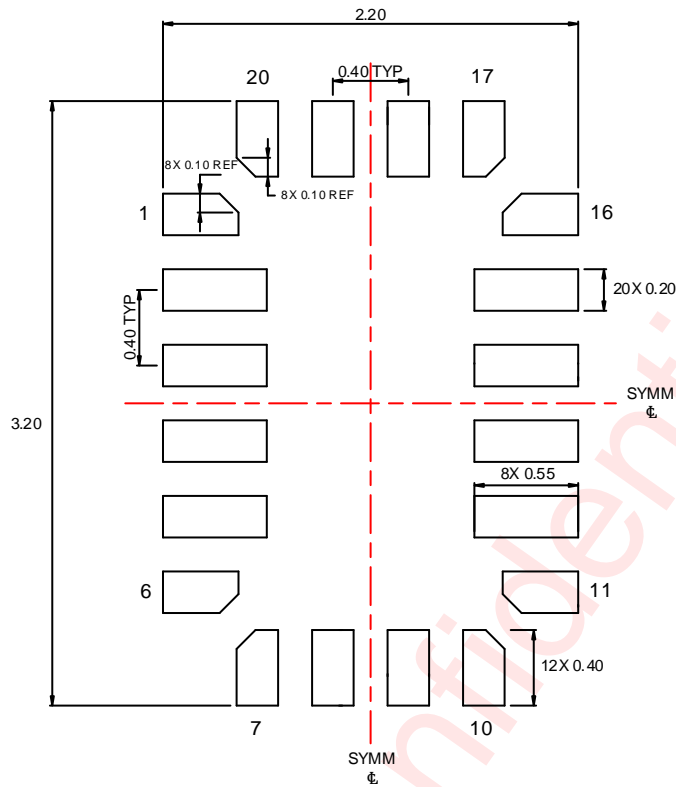

NON-SOLDER MASK DEFINED

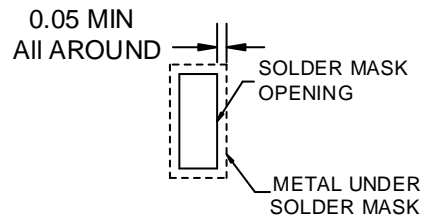

SOLDER MASK DEFINED

Unit: mm

Revision History

Version	Date	Change Record
V1.0	May 2020	Official Version
V1.1	June 2020	Modify interface description of IIS
V1.2	June 2020	Modify timing description of IIS and quiescent current
V1.3	July 2020	Revise the description of OVP
V1.4	August 2020	Delete the maximum output current
V1.5	January 2021	Add playback of one wire mode Modify power on and power down sequence Add IQ vs VBAT and delete LRA res vs temp Add BST_BRK_GAIN register Modify TRIG1/2/3 and INTN PIN description
V1.6	March 2021	Revise RL calculation formula
V1.7	April 2021	Revise CHIPID in 0x00 register Add one wire playback steps Add GAIN_BYPASS register Add auto-brake restriction
V1.8	May 2021	Revise PIN RCK description Revise PCB Layout Consideration
V1.9	September 2021	Revise PIN description Revise playback mode description Add RL and VBAT detection steps Revise register description Add BRK_BST_MD and START_DLY register Modify PCB Layout Consideration Revise Inductor Selection Guideline
V2.0	March 2022	Revise C6/C7 of Typical Application Circuit Add minimum I2C speed of rtp mode data transmission Add WAKE/STANDBY register Add F _{PWM} and Revise Ton2 in Electrical Characteristics Revise PCB Layout
V2.1	November 2022	Revise and unify format Add delay after open ram init clock

Disclaimer

Information in this document is believed to be accurate and reliable. However, Shanghai AWINIC Technology Co., Ltd (AWINIC Technology) does not give any representations or warranties, expressed or implied, as to the accuracy or completeness of such information and shall have no liability for the consequences of use of such information.

AWINIC Technology reserves the right to make changes to information published in this document, including without limitation specifications and product descriptions, at any time and without notice. Customers shall obtain the latest relevant information before placing orders and shall verify that such information is current and complete. This document supersedes and replaces all information supplied prior to the publication hereof.

AWINIC Technology products are not designed, authorized or warranted to be suitable for use in medical, military, aircraft, space or life support equipment, nor in applications where failure or malfunction of an AWINIC Technology product can reasonably be expected to result in personal injury, death or severe property or environmental damage. AWINIC Technology accepts no liability for inclusion and/or use of AWINIC Technology products in such equipment or applications and therefore such inclusion and/or use is at the customer's own risk.

Applications that are described herein for any of these products are for illustrative purposes only. AWINIC Technology makes no representation or warranty that such applications will be suitable for the specified use without further testing or modification.

All products are sold subject to the general terms and conditions of commercial sale supplied at the time of order acknowledgement.

Nothing in this document may be interpreted or construed as an offer to sell products that is open for acceptance or the grant, conveyance or implication of any license under any copyrights, patents or other industrial or intellectual property rights.

Reproduction of AWINIC information in AWINIC data books or data sheets is permissible only if reproduction is without alteration and is accompanied by all associated warranties, conditions, limitations, and notices. AWINIC is not responsible or liable for such altered documentation. Information of third parties may be subject to additional restrictions.

Resale of AWINIC components or services with statements different from or beyond the parameters stated by AWINIC for that component or service voids all express and any implied warranties for the associated AWINIC component or service and is an unfair and deceptive business practice. AWINIC is not responsible or liable for any such statements.